



ENDURA TRI-PROOF CCT LED BATTEN

22752/08	Grey	20W	No sensor
22753/08	Grey	20W	Corridor function and microwave sensor
22755/08	Grey	40W	

Before first using your new fitting, it is most important that you read and follow these instructions, even if you feel you are quite familiar with this type of product. Retain this document for future reference.

THIS FITTING MUST BE INSTALLED BY A QUALIFIED ELECTRICIAN in accordance with the latest AS/NZS 3000 Standards and relevant Amendments *

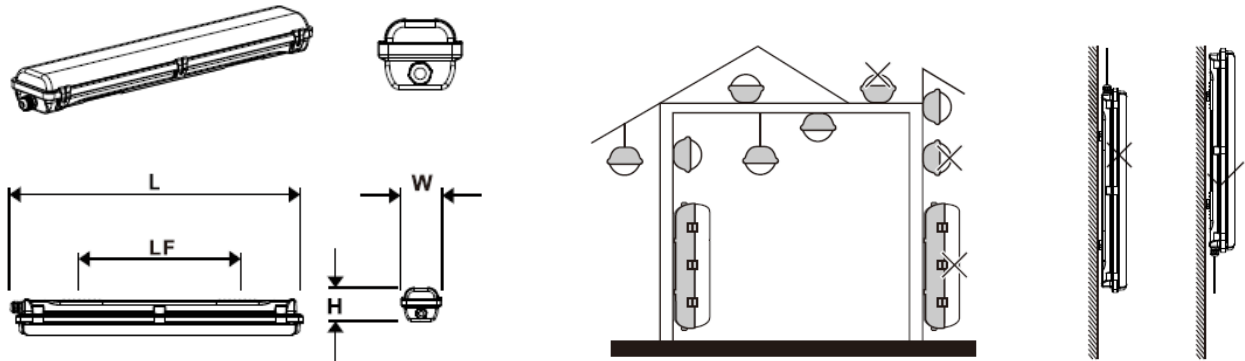

Model : 22755 Dimension: L= 1238mm W = 120mm H = 76mm LF = 800mm

Model: 22752 & 22753 Dimension: L= 660mm W= 120mm H = 76mm LF = 350mm

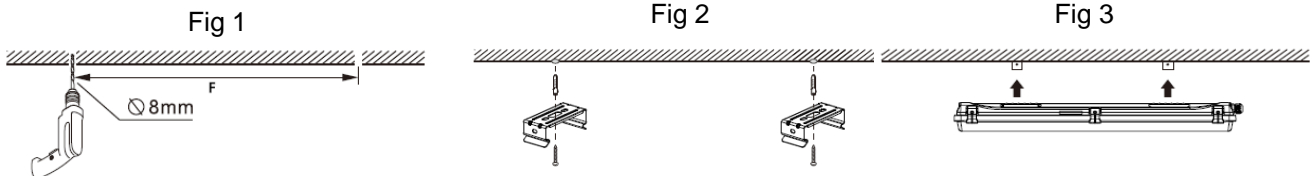

Mounting Instructions:

1. Mark the ceiling on required distance between the brackets 'LF' (Note: check the minimum and maximum distances).
2. Drill \varnothing 8mm holes. (Figure 1)
3. Use screws and suitable fixture system to secure the brackets to the ceiling (Figure 2).
The next step is to connect mains supply cable and programming the fitting using DIP switches, explained on the next pages.
4. Attach the Luminaire to the brackets. (Figure 3). Installation completed.

WARNINGS

- To prevent electrical shock, ensure that POWER is DISCONNECTED before installation and or maintenance.
- Installation, maintenance and inspection for safety concerns should be done by a qualified personnel.
- Do not touch any parts of the assembly with bare hands while it is hot.
- Do not install in a position where the fitting can be easily accessed by children.
- Be aware of the height of your installation. Refer to '**Working at Heights**' guide from your local or State Authorities.
- (*)Any alterations or additions to building wiring **must be completed by a licensed electrician** or person authorised by legislation to work on the fixed wiring of any electrical installation.
- Do not disassemble or remould the product to avoid electrical shock or to cause failure of the light.
- Ensure it is installed in well ventilated area.
- Working, out of temperature range of -20° C to $+40^{\circ}$ C will shorten the lifetime of the product.



ENDURA TRI-PROOF CCT LED BATTEN

22752/08	Grey	20W	No sensor
22753/08	Grey	20W	Corridor function and microwave sensor
22755/08	Grey	40W	

Fig 5

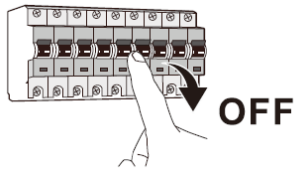

Fig 6

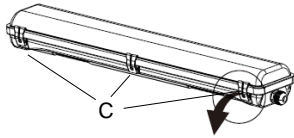

Fig 7

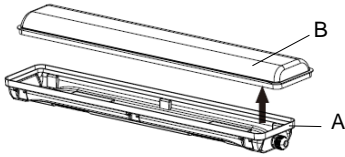

Fig 8

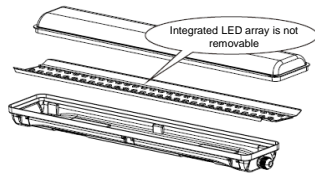

Fig 9

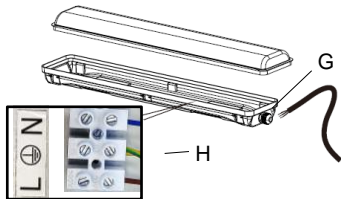

Fig 10

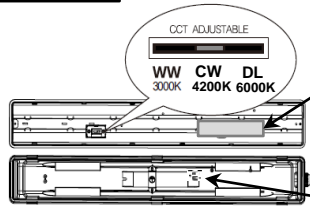

Fig 11

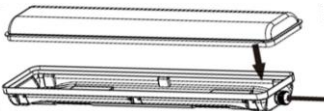
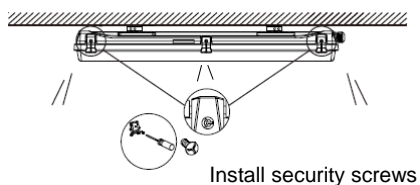

Fig 12



Fig 13



Install security screws

Installation instructions continued:

1. Ensure mains supply is switched OFF. (Fig 5)
2. Gently release the metal clips 'C' from both sides of the fitting, (Fig 6) ; (6 clips 22752 & 22753 ; 10 clips 22755) and open the fitting.
3. Remove diffuser assembly 'B' from light body 'A' (Fig 7) Diffuser assembly 'B' is held by plastic lanyard to body 'A'.
4. (Fig 8) shows that the LED array is installed inside the diffuser assembly 'B' and it is not removable.
5. Run the mains cable through the cable glad 'G'.
6. Connect Live (L), Neutral (N) and Earth according to the markings on the terminal block 'H', (Fig 9). Ensure connections are secure.
7. Select colour temperature with CCT switch: (WW) Warm White - (CW) Cool White- (DL) Daylight; (Fig 10)
7. Power setting can be selected with DIP Switches 'D' 1, 2 located on the driver. 4 possible combinations are possible. Refer to the marking on the driver.
8. 22753 & 22755 only-Using DIP switches on the Microwave Sensor 'M' select the desired programming scenario. Refer next page for details.
8. Refit the Diffuser. (Fig 11)
9. Lock in the clamps. (Fig 12)
10. Use security screws to secure the metal clamps. (Fig 13)
11. Turn the power ON. (Fig 14)

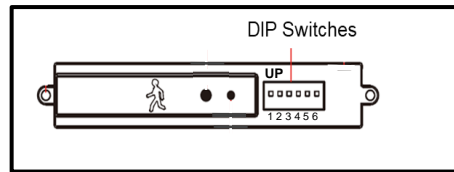

Microwave sensor
Models 22753
22755 only

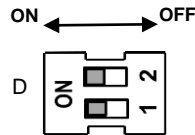

Power switches located on driver.
Refer combinations below:

I rated	1	2	22752 22753	22755
350mA	ON	ON	20W	40W
300mA	-	ON	18W	33W
250mA	ON	-	15W	28W
200mA	-	-	12W	22W

Fig 14

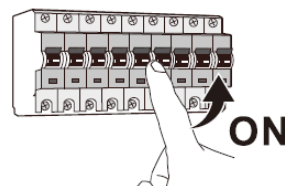



ENDURA TRI-PROOF CCT LED BATTEN

22752/08	Grey	20W	No sensor
22753/08	Grey	20W	Corridor function and microwave sensor
22755/08	Grey	40W	Corridor function and microwave sensor

Operation

The Model: 22752 has no sensor and it works just as an ordinary light fitting. The 22753 & 22755 models have built-in microwave sensor and they are programmable via DIP switches. When movement is detected the 22753 & 22755 models work accordingly to the settings on the DIP switches. Refer below to the detection patterns and the DIP switch functions.

Detection Patterns (Model 22753 & 22755 only)

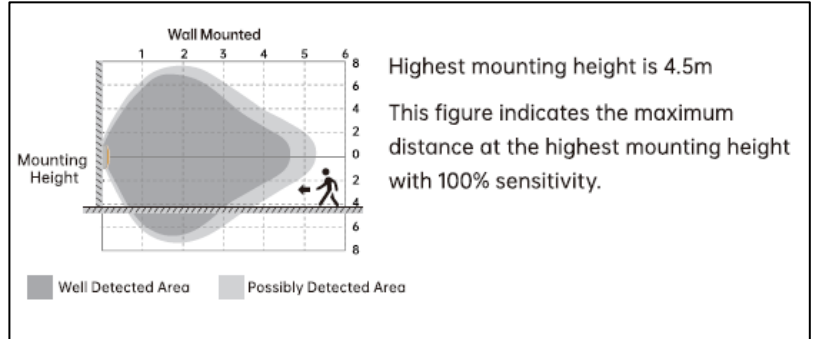
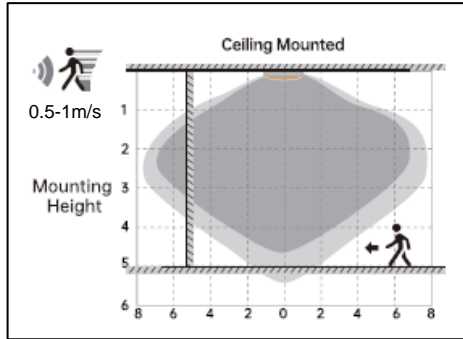

DIP switch functions on Microwave sensor (Model 22753 & 22755 only)

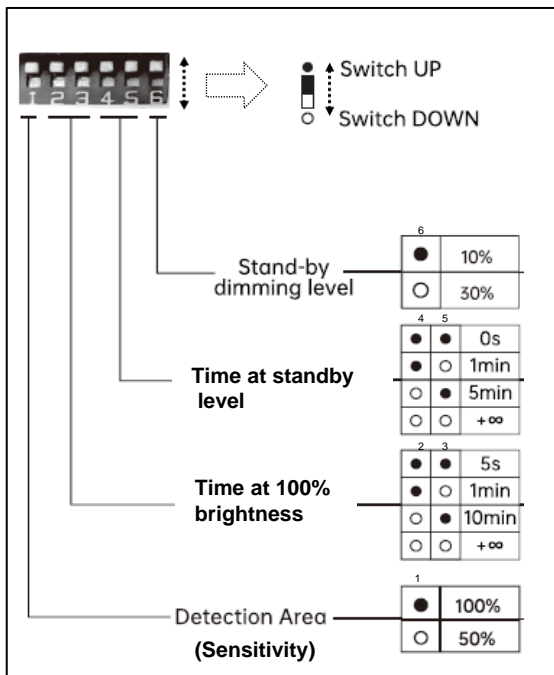
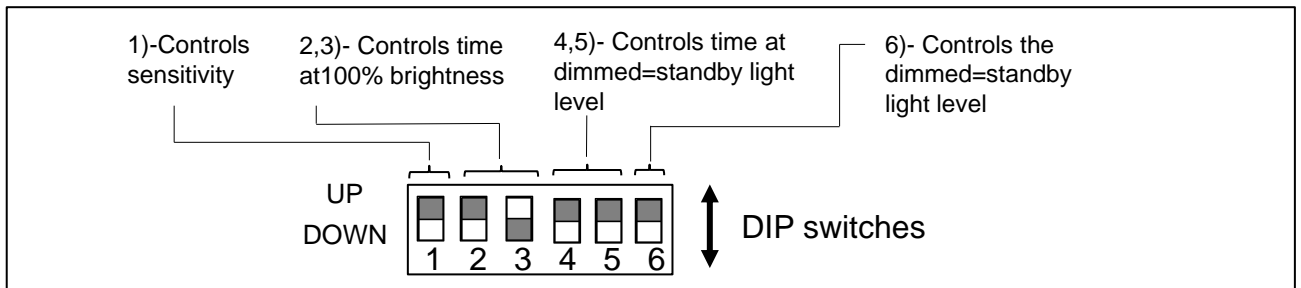

Examples of DIP switch settings & comments when MWS detects movement

DIP Switch	Comments
	Light comes ON @100% for 1min then turns completely OFF.
	Light comes ON 100% for 1 min then stays ON @ 10% for another 1 min. After 2 min completely turns OFF.
	Light comes ON @100% for 5 sec then turns completely OFF.
	Light comes ON 100% for 5 sec then stays ON @ 10% for 1 min. After 1 min completely turns OFF
	Light comes ON 100 % for 5 sec then stays ON @ 10% for 5 min. After 5 min completely turns OFF.
	Light comes ON 100% for 5s then stays on @ 10% dimmed level for infinity (always) .

Other combinations are possible



ENDURA TRI-PROOF CCT LED BATTEN

22752/08	Grey	20W	No sensor
22753/08	Grey	20W	Corridor function and microwave sensor
22755/08	Grey	40W	

Specifications

Model No:	22753 MW 60cm 12W/15W/18W/20W	22755 MW 120cm 22W/28W/33W/40W	22752 60cm 12W/15W/18W/20W
Fitting:	Polycarbonate Body and frosted diffuser		
Protection:	Class I , IP66, IK08		
Rating:	220-240V AC 50Hz		
LED	LED ARRAY (non replaceable)		
Lumens	2200lm max	4200lm max	2200lm max
CCT	WW 3000K CW 4200K DL 6000K		
Microwave sensor	5.8GHz+/1 75MHz , Φ6m x 14m ; Dimming level 10% & 30%; 'Stand By' and '100% brightness' time is programmable from 0s/1min/5min/∞ ;		N/A
Dimensions	660 x 120 x 76 mm	1238 x 120 x 76 mm	660x 120x76mm
Weight	1kg	1.8kg	1kg

Environmental Protection:

This electrical product should not be disposed as normal waste. Please always recycle! Check with your Local Council about your recycling options.



Warranty:

Brilliant Lighting warrants this product against defects in manufacture and workmanship for a period of 3 years from date of purchase or as specified on the packaging. This warranty is only valid for products installed by a qualified electrical contractor and operated within the guidelines specified by Brilliant Lighting, and within the correct operating voltage ranges as stated on the product's rating label.

Warranty does not include damage or loss arising from incorrect installation, operation or maintenance of this product, damage caused through modification, incorrect installation, service by unqualified or unauthorised personnel or lack of regular maintenance and cleaning. Proof of installation by qualified personnel may be required, eg. Electrical Safety Certificate. Proof of purchase must be supplied with all warranty claims.

This warranty is provided in addition to any other rights and remedies of the customer under any law. In applications not intended for household, personal or domestic use, liability is limited to replacement or reimbursement of product only. Brilliant Lighting does not warranty the costs of removal or re-installation of this product or associated components.

Our goods come with guarantees that cannot be excluded under the Australian Consumer Law. You are entitled to a replacement or refund for a major failure and compensation for any other reasonably foreseeable loss or damage. You are also entitled to have the goods repaired or replaced if goods fail to be of acceptable quality and the failure does not amount to a major failure.

Any claim under this warranty must be made within specified warranty period from date of purchase of this product. To make a claim under the warranty at your own expense take the product (with proof of purchase – receipt or similar) to the store where you purchased the product or contact Brilliant Lighting at the address below.

This warranty is given by:

Brilliant Lighting (Aust) Pty. Ltd.

ABN 37 006 203 694

956 Stud Road Rowville, VIC 3178

Phone: 03 9765 2555

Email: warranty@brilliantlighting.com.au

Made in China