

**CLIPSAL**

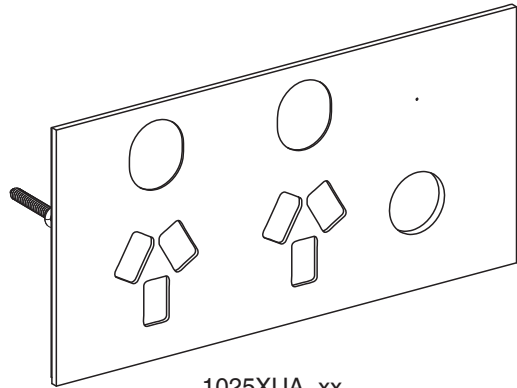

1025XUA\_xx

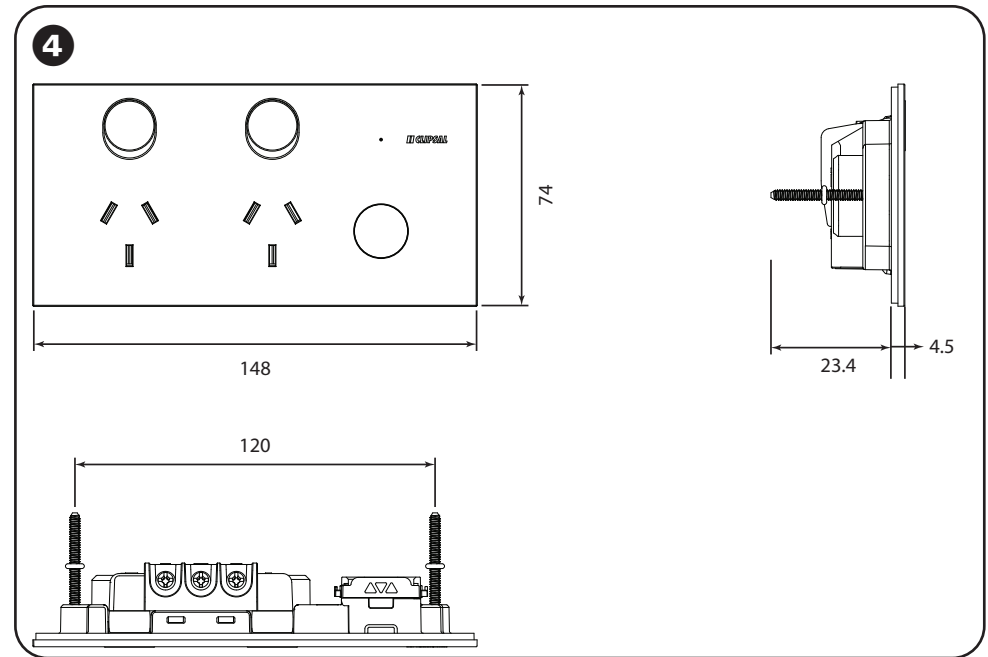
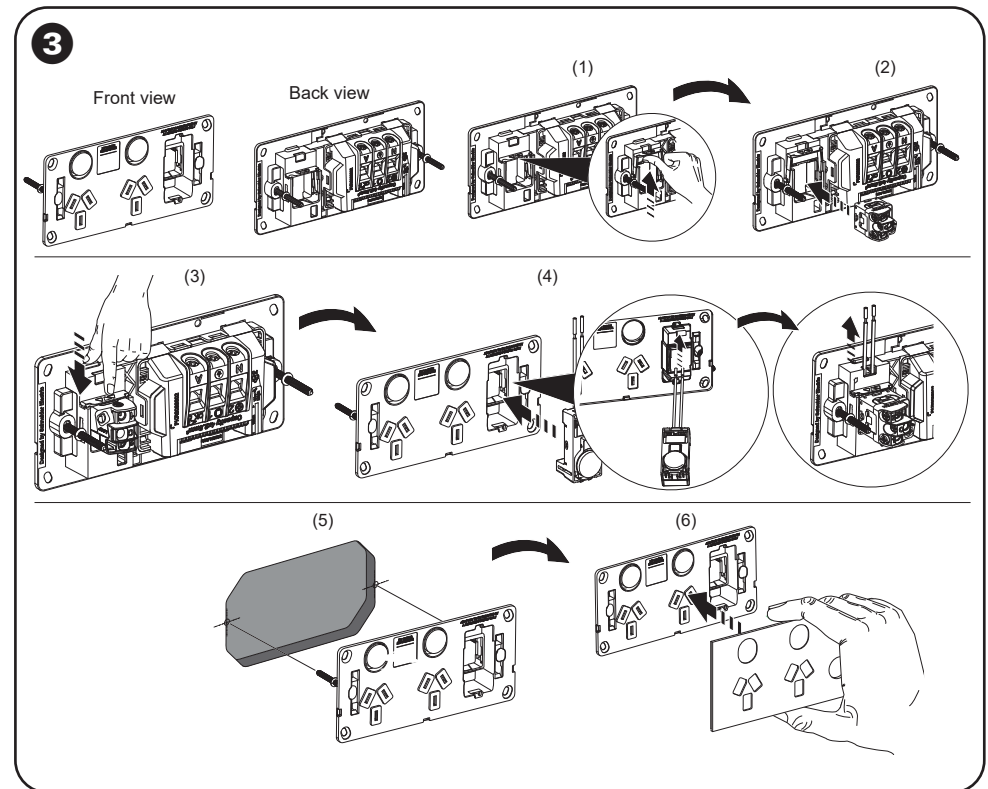
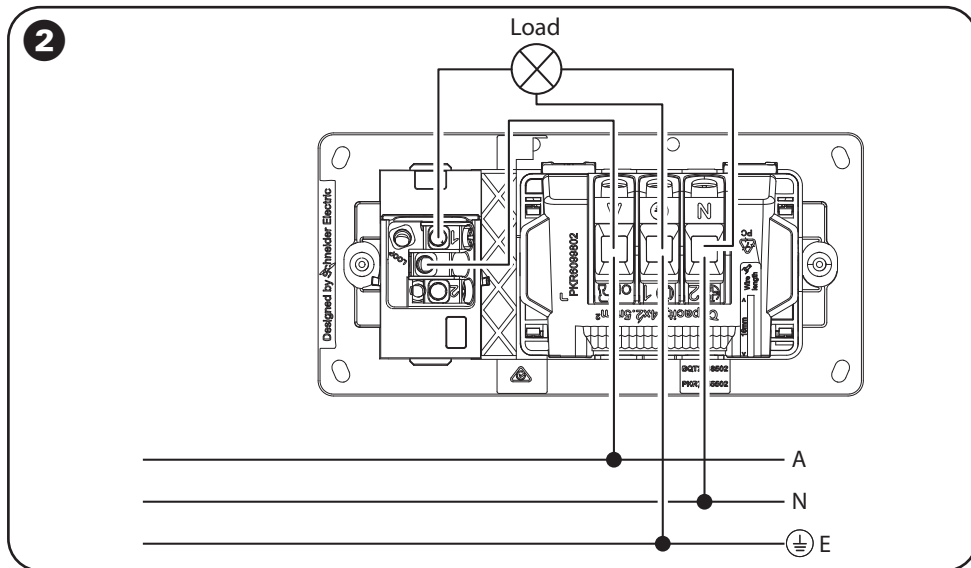
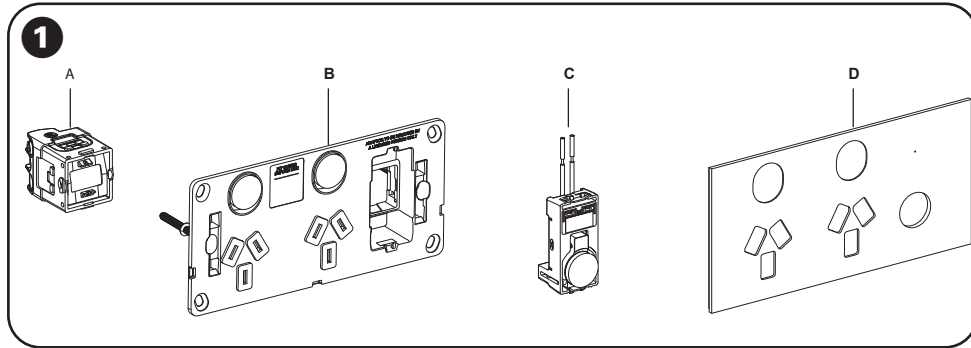

## Socket Switched Horizontal Twin, 1ExBLANK

### Product Range

Cat No.	Description	Range
1025XUA-XX	Double Switch Power Point, Horizontal Mount, 230V-240V, 10A, Removable Extra Switch	Clipsal Solis™, Clipsal Solis™ T Series

### 1 Package contents

- B Grid plate
- D Cover plate

### 2 Wiring diagram and electrical connections

#### **⚠ ⚠ DANGER**

#### **HAZARD OF ELECTRIC SHOCK, EXPLOSION, OR ARC FLASH**

- This product must be installed and serviced by appropriately qualified and/or licensed electrical personnel.
- Connecting to installation networks.
- Connecting several electrical devices.
- Laying electric cables.
- Safety standards, local wiring rules and regulations.

**Failure to follow this instruction will result in death or serious injury.**

A - Active, N - Neutral, E - Earth

### 3 Pre-installation

#### **⚠ CAUTION**

#### **EQUIPMENT DAMAGE HAZARD**

- Install the device according to instructions in this document.
- Pay attention to the specifications and wiring diagrams related to the installation.
- Do not use the device for any other purpose than specified in this instruction.
- Dropping the device may damage the internal components. Check that the device operates after being dropped or if physical damage is shown.

**Failure to follow these instructions can result in injury or equipment damage.**

- (1) Open the locking bar on the rear side of the grid plate.
- (2) Install the **Mechanical switch** from the rear side of the grid plate.
- (3) Close the locking bar after installing the switch.
- (4) Attach the push button adapter to the front side of the grid plate, feed the wire into the designated hole above the slot, and secure the adapter in place.
- (5) Mount the cover plate onto the grid plate from the front side. (Refer to the wiring as shown in the illustration 2.)

### 4 Dimensional drawings

#### Technical data

Rated voltage	230/240 Vac, 50 Hz
Rated current	10 A
Standards	AS/NZS 3112; AS/NZS 3133
Number of outlets	2
Number of switches	2 (extra switch not supplied)
Cover plate material	Recycled plastic

RCM



#### Warranty Information (Australia)

We warrant this product for 2 years—visit

<https://www.schneider-electric.com.au/en/about-us/legal/terms-and-conditions.jsp> for details.

Our goods also come with guarantees that cannot be excluded under the Australian Consumer Law. You are entitled to a replacement or refund for a major failure and compensation for any other reasonably foreseeable loss or damage. You are also entitled to have the goods repaired or replaced if the goods fail to be of acceptable quality and the failure does not amount to a major failure.

#### Schneider Electric (Australia) Pty Ltd

33-37 Port Wakefield Road, Gepps Cross SA 5094

Customer Care: 13 73 28

Email: [customer care.au@se.com](mailto:customer care.au@se.com)

[www.schneider-electric.com.au](http://www.schneider-electric.com.au)

#### Schneider Electric (NZ) Ltd

Building 6, 60 Highbrook Drive, East Tamaki,

Auckland 2013, New Zealand

Customer Care: 0800 741 303

Email: [customersupport.nz@se.com](mailto:customersupport.nz@se.com)

[www.schneider-electric.com](http://www.schneider-electric.com)

Schneider Electric reserves the right to change specifications, modify designs and discontinue items without incurring obligation and whilst every effort is made to ensure that descriptions, specifications and other information in this instruction is correct, no warranty is given in respect thereof and the company shall not be liable for any error therein.

#### Trademarks

This product is the subject of one or more patent and/or design applications and/or registrations. More information can be found on our website.

© 2024 Schneider Electric. All Rights Reserved. Schneider Electric, Clipsal, Clipsal Solis and Life Is On Schneider Electric are trademarks and the property of Schneider Electric, its subsidiaries, and affiliated companies.

All other trademarks are the property of their respective owners. Packaging made from recycled and recyclable materials.