

LE-200 ETHERNET IP

Order-#: 2200-00702

7.10.2021 / 010203020002030199

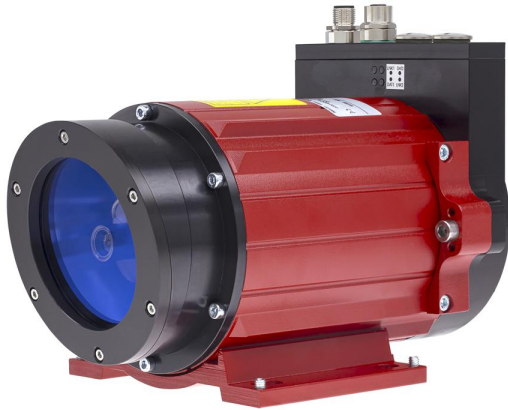

Stock photo

Ethernet/IP



Advantages

- Customer-specific solutions
- Flexible programming
- Further interfaces available
- Measures linear movements
- Measuring dista. 125/170/190
- Rugged construction
- Wear-free detection

Technical data for 2200-00702

RESOLUTION	1,0
MEASURING RANGE	125M
INTERFACE	ETHERNET IP
CODE	PROGRAMABLE
OUTPUT LEVEL	RS485
SUPPLY VOLTAGE	18-27V
CONNECTOR TYPE	1X4P+8P MALE/4P FEMALE/M12
CONNECTOR-POSITION	RADIAL
TEMPERATURE RANGE	0-50°C
PROTECTION Class	IP65
LASER PROTECTION CLASS	2

Subject to change.

TR-Electronic GmbH
 Eglisshalde 6
 78647 Trossingen
 Tel. +49 (0) 7425 228-0
 info@tr-electronic.de
www.tr-electronic.de

LE-200 ETHERNET IP

Order-#: 2200-00702

7.10.2021 / 010203020002030199

Technical data for 2200-00702 continuation

OPTIONS ENC	12MBAUD
	FULL STROKE LINEARIZED
	PROGRAMMABLE
REFLECTIVE-FOIL	YES
WATER COOLING	NO
PINOUT NO.	TR-ELE-TI-DGB-0014
DRAWING NO.	04-K2200-014
DOCUMENTATION NO	DOKUMENTE
AL:	N
ECCN:	N

General data for K-LE200-EIP-1

Characteristics - Validity	Min. operation time > 30 min
Supply	
- Supply voltage	18...27 VDC \pm 5%
Current consumption no load	\leq 350 mA
Integrated heating	
- Equipment	Option
- Nominal voltage	24 VDC \pm 5 %
- Nominal power	48 W
Measuring principle	Phase shift measurement
Measuring length	
- Measuring against	Reflector foil
- Standard measuring range	0.2... 125 m
- Range extension 1	170 m
- Range extension 2	195 m
Resolution	0.1 mm physically
Linearity deviation	\pm 3 mm \leq 12 m, absolute
	\pm 5 mm FS, absolute
- FS:	Full-Scale
Reproducibility	\pm 2 mm
Light source	
- Laser diode	Red light
- Wave length λ	670 nm
- Laser protection class	2
- International safety standard	IEC 60825-1

Subject to change.

LE-200 ETHERNET IP

Order-#: 2200-00702

7.10.2021 / 010203020002030199

General data for K-LE200-EIP-1 continuation

- American safety standard	FDA 21CFR 1040.10 / 1040.11
- American safety standard	observe "Laser-Notice No. 50"
- Radiant power P	<= 1 mW
Measurand output/refresh rate	1000 Values/s
Integration time	1 ms
EtherNet/IP™ - Interface	
- EtherNet/IP™	IEC 61784-1 CP 2/2, IEC 61158
- Physical Layer	Fast Ethernet, ISO/IEC 8802-3
- Device profile	Encoder Device Profile 0x22
Transmission rate	
- Specific value	100 MBit/s
Parameter/Function, changeable	Addressing
	Resolution
	Error outputs
	Intensity parameter
	Preset parameter
	Adjustment - Parameter
	Temperature parameter
	Counting direction
	Velocity parameter
Type of parametrization	programmable
Programming - Tool	Fieldbus-Device
	TR-Soft: TRWinProg
External inputs	
- Function input	Preset adjustment
- Function input	Switch-off of the laser diode
- Function input	Error acknowledgement
- Type of parametrization	programmable
- Logic level, LOW	"0" < +2 V, <= ±35 V, 5 kOhm
- Logic level, HIGH	"1" > +8 V
- Number of inputs	1
External outputs	
- Status output	Temperature
- Status output	Intensity
- Status output	Hardware
- Status output	Speed
- Status output	Position
- Logic level, LOW	"0" < 1 V, <= 100 mA

Subject to change.

LE-200 ETHERNET IP

Order-#: 2200-00702

7.10.2021 / 010203020002030199

General data for K-LE200-EIP-1 continuation

- Logic level, HIGH	"1" > Supply Voltage – 2 V
- Type of parametrization	programmable
- Number of outputs	1

Environmental data

Vibration	
- Specific value	$\leq 50 \text{ m/s}^2$
- Sine	50...2000 Hz
Shock	
- Specific value	$\leq 300 \text{ m/s}^2$
- Half sine	11 ms
Immunity to disturbance	DIN EN 61000-6-2
Transient emissions	DIN EN 61000-6-3
Working temperature	
- Standard	0...+50 °C
- Optional	-30...+50 °C;
Storage temperature, dry	-20...+75 °C
Temperature drift	1 ppm/°C $\leq 125 \text{ m}$
	1 ppm/°C $\leq 170 \text{ m}$
	1 ppm/°C $\leq 195 \text{ m}$
Relative humidity	98 %, non condensing
Protection class	
- Standard	IP65

Subject to change.

4pol. M12-Buchse
D-kodiert

8pol. M12-Stecker
A-kodiert

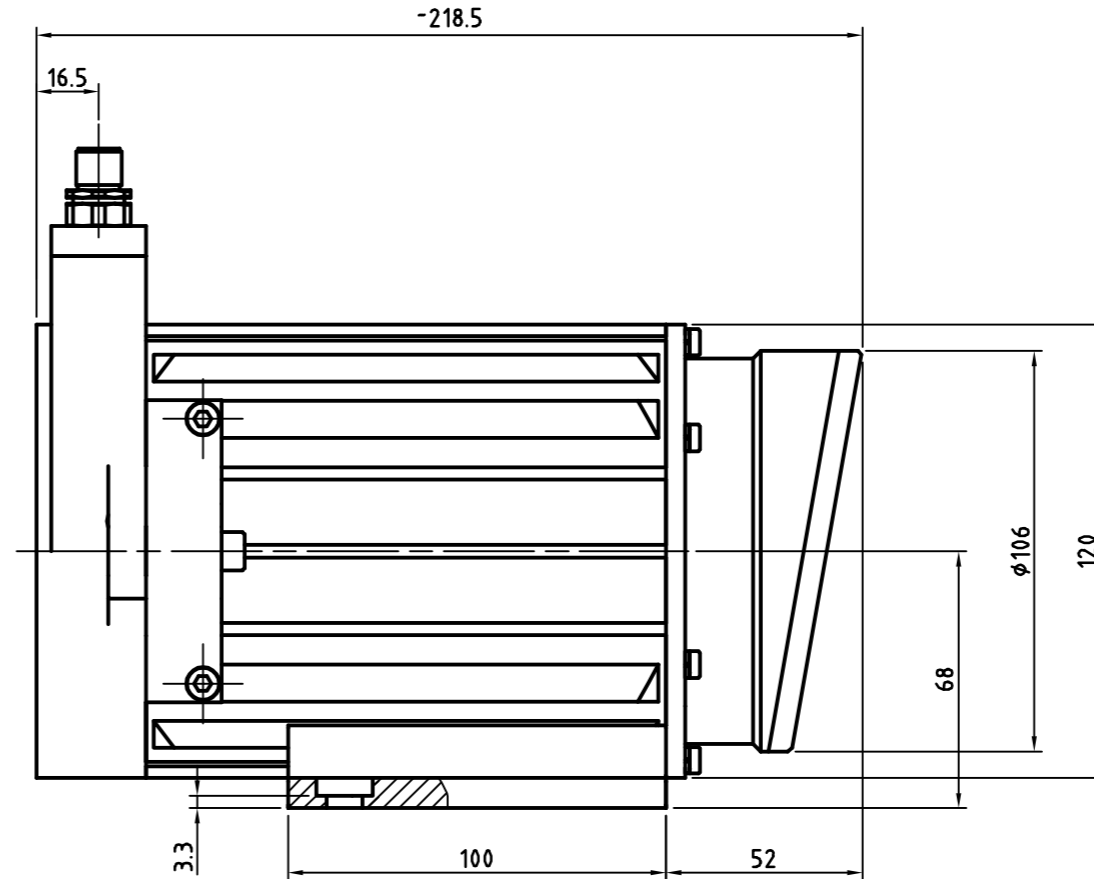
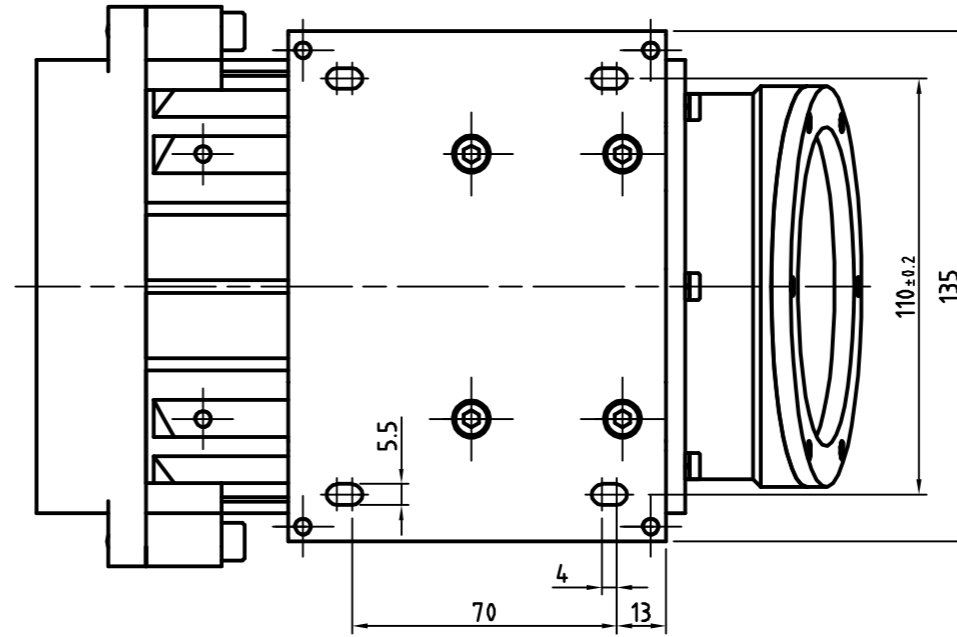
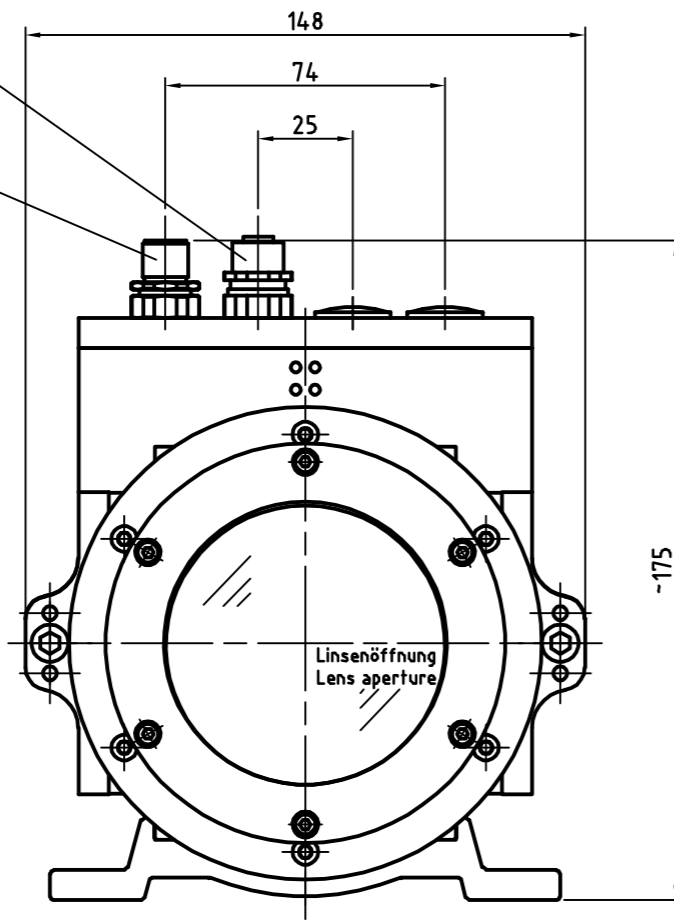

Artikel-Nr. und Steckerbelegung: siehe Datenblatt
Article-No. and pin connections: see data sheet

 TR Electronic GmbH Eglisshalde 6 78647 Trossingen Telefon 07425/228-0	Maßstab 1:2 DIN A3 Projekt-Nr.:				
	Zeichnungs-Nr. nur für diese Ausführung gültig Drawing-No. only for this type valid				
Datum Name Erstellt 21.04.2010 STIER Bearb. 21.04.2010 STIER Gepr. Norm		LE-200			
www.tr-electronic.de DXF+Info: info@tr-electronic.de					
Zust.	Änderung	Datum	Name	Zeichnungs-NR../Drawing-No.: 04-K2200-014	Blatt 1
					Bl

Steckerbelegung / Pin assignment

Laser LE-200 EtherNet/IP™

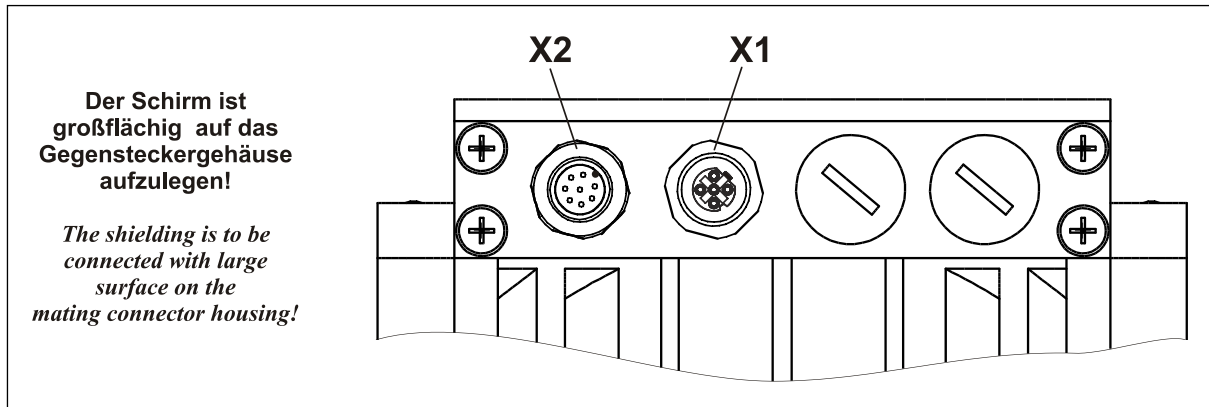

X1	IN / OUT; Flanschdose / Female socket (M12x1-4 pol. D-coded)			
1	TxD+	Sendedaten +	Transmission Data +	
2	RxD+	Empfangsdaten +	Receive Data +	
3	TxD-	Sendedaten -	Transmission Data -	
4	RxD-	Empfangsdaten -	Receive Data -	

X2	Flanschstecker / Male socket (M12x1-8 pol. A-coded)		
1	18 – 27 V DC / 24 V DC;	Supply voltage Standard / Heizung (Heating)	
2	GND, 0V;	Versorgung / Supply voltage	
3	TRWinProg +;	nur für Servicezwecke / for service purposes only	
4	TRWinProg -;	nur für Servicezwecke / for service purposes only	
5	Switching Input;	High: > +8V, Low: < +2V	
6	Switching Output;	High: > US-2V, Low: < 1V	
7/8	N.C.		

Address: 1...254 (0x01...0xFE)

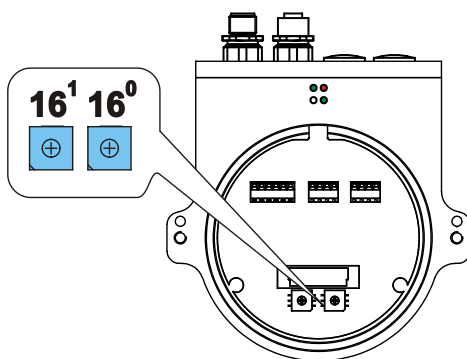

TCP/IP Object, Attr. ID 3: Config Control	Schalter / Switches	Aktion / Action	Beschreibung / Description
0x00	0x00, 0xFF	Flash Konfiguration / Flash configuration	-
0x00, 0x02	≠0x00, 0xFF	Schaltereinstellung / Switch adjustment	IP-Address: 192.168.1.xxx Network Mask: 255.255.255.0 Gateway Address 192.168.1.254
0x02	0x00, 0xFF	DHCP Anfrage / DHCP request	Configuration DHCP Server

Steckerbelegung / Pin assignment

LEDs

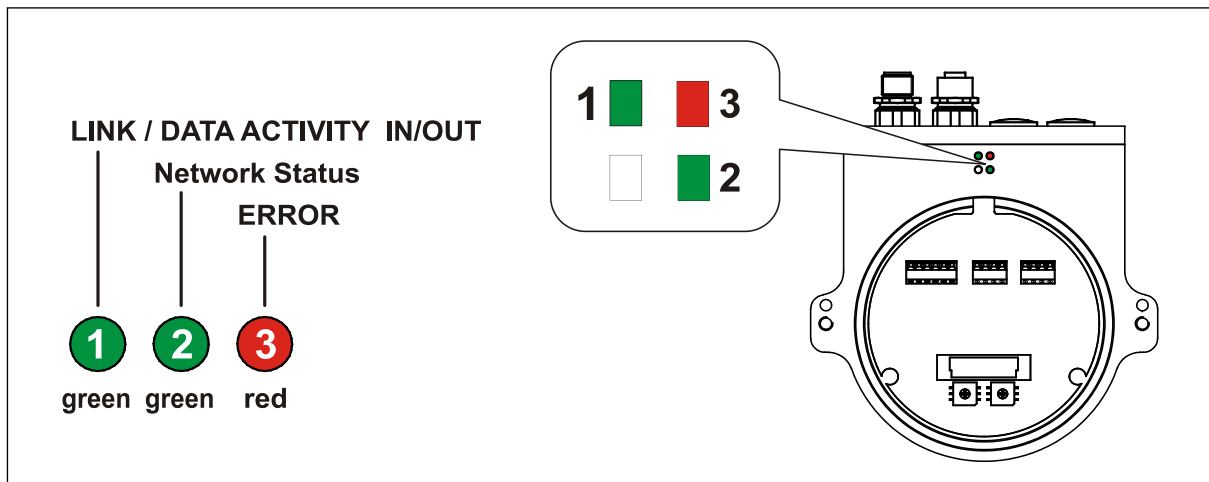

Link / Data Activity

LED Status	Beschreibung / Description
ON = Link	Ethernet Verbindung hergestellt / <i>Ethernet connection established</i>
Flashing = Data Activity	Datenübertragung TxD/RxD / <i>Data transfer TxD/RxD</i>

Network-Status

LED Status	Ursache / Cause	Beschreibung / Description
OFF	keine Versorgungsspannung, oder IP-Adresse / <i>Not powered, no IP address</i>	Das Gerät ist nicht mit Spannung versorgt, oder es wurde keine IP-Adresse zugewiesen / <i>Device is not powered or does not have an IP address</i>
1 Hz	keine Verbindungen / <i>No connections</i>	Es wurden keine Verbindungen hergestellt, aber eine IP-Adresse wurde zugewiesen / <i>Device has no established connections, but has obtained an IP address</i>
ON	Verbindung hergestellt / <i>Connected</i>	Gerät hat mindestens eine Verbindung hergestellt, z.B. zum Message Router / <i>The device has at least one established connection, e.g. to the Message Router</i>
1 Hz green/red	Selbsttest / <i>Self-test</i>	Gerät führt im Einschaltmoment einen Selbsttest durch / <i>Valid, while the device is performing its power up testing</i>

Error

LED Status	Ursache / Cause	Beschreibung / Description
1 Hz	Verbindungs-Timeout <i>Connection Timeout</i>	Eine oder mehrere Verbindungen zum Gerät sind im Timeout Zustand. Der Zustand wird nur verlassen, wenn alle Verbindungen wieder hergestellt wurden, oder ein Geräte-RESET vorgenommen wurde. / <i>One or more of the connections in which this device is the target has timed out. This state is left only if all timed out connections are re-established or if the device is reset.</i>
ON	Duplizierte IP <i>Duplicate IP</i>	Gerät hat festgestellt, dass seine eigene IP-Adresse mehrfach im Netzwerk vergeben wurde / <i>The device has detected that its IP address is already in use</i>
1 Hz green/red	Selbsttest / <i>Self-test</i>	Gerät führt im Einschaltmoment einen Selbsttest durch / <i>Valid, while the device is performing its power up testing</i>