



Power Your Freedom

Portable Solar Panel

# User Manual

JER-120-SP-AG

**120w**

[www.jerifreedom.com.au](http://www.jerifreedom.com.au)

# IMPORTANT SAFETY INSTRUCTIONS



Read all instructions before using this product to avoid personal injury and property damage.



- Do not bend the solar panel.
- Do not immerse the solar panel into water or any other liquid.
- Do not use or store your jeri solar panel near fire or heater.
- Do not scratch the solar panel with sharp objects.
- Do not step or place heavy objects on your jeri solar panel.
- Do not allow the disassembling of the solar panel by unauthorised individuals or repair centres.
- Do not put corrosive substance on your jeri solar panel.
- Do not drop your jeri solar panel from heights or expose it to physical impact.
- The output of the solar panel must be correctly connected to the equipment.
- For safety purpose, check the status of each component, including cables, wires and plugs before connection.
- To maximize the output power from your jeri portable solar panel, use it at a place where can face direct sunlight and away from shadows.

## Note:

While charging your jeri portable power station through the portable solar panel, please keep the portable power station away from heat or direct sunlight to extend its life span.



# Index

Items Included	4
Product Information	5 - 6
Specifications	6
FAQ	7
Warranty and Registration	8 - 11

# Items Included

Portable Solar Panel

JER-120-SP-AG

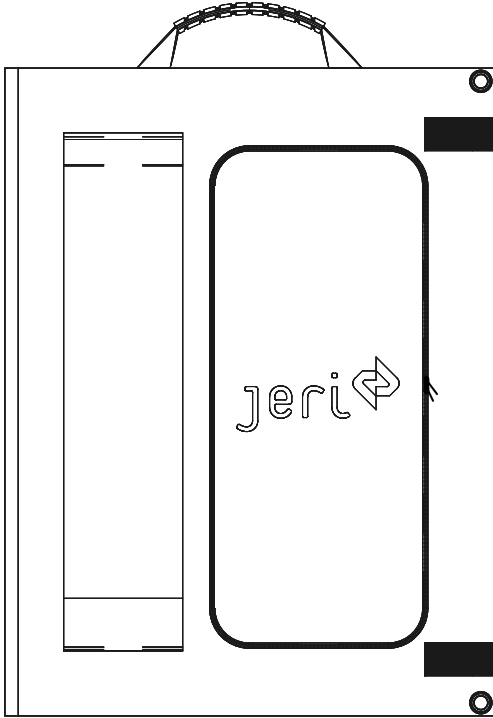

Solar Panel

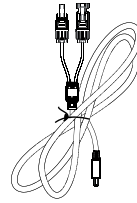

MC4 to 5525 Plug cable

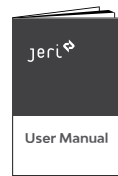

User Manual



## How to Use Your jeri Portable Solar Panel

### Step 1

Unbuckle the portable solar panel.

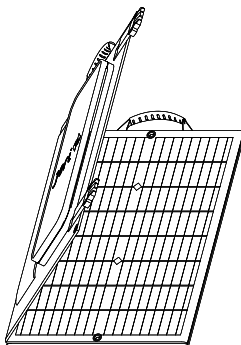

### Step 2

Unfold the portable solar panel.

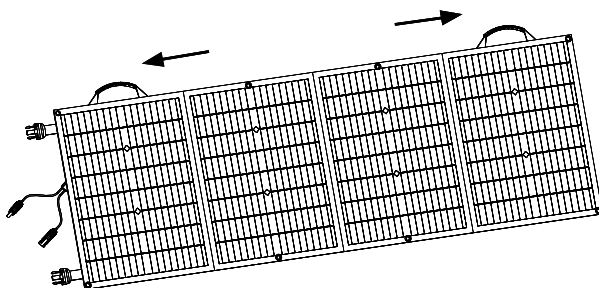

### Step 3

Two adjustable angles available for support legs.

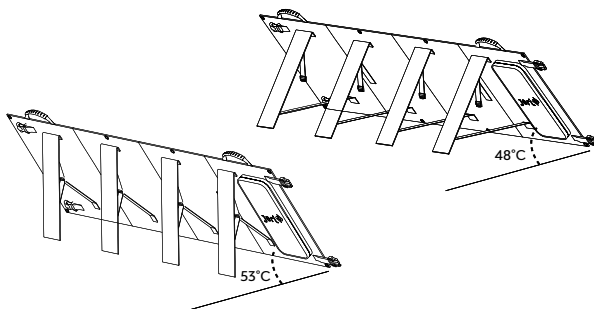

## How to Use Your jeri Portable Solar Panel

### Step 4

Use the MC4 to 5525 Plug cable to connect the MC4 plug from the portable solar panel and the DC input from the portable power station.

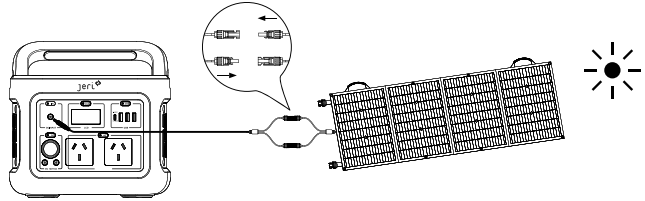

## Specifications

<b>Model</b>	JER-120-SP-AG
<b>Cell Type</b>	Monocrystalline Silicon
<b>Solar Cell Efficiency</b>	22%
<b>Rated Power</b>	120W
<b>Open Circuit Voltage</b>	21.85V
<b>Short Circuit Current</b>	6.67A
<b>Operation Temperature</b>	-10°C ~ 65°C
<b>Folding Number</b>	4
<b>Dimension (unfolded)</b>	493 * 1486 * 25mm
<b>Dimension (folded)</b>	493 * 364 * 54mm
<b>Weight</b>	4.63 kg
<b>Warranty</b>	12 Month
<b>Certification</b>	PSE, RCM

\*Rated Power is tested under Standard Test Conditions: 1000W/m2, AM1.5, 25°C.

## FAQ

### Does the charging speed of jeri portable solar panel vary?

jeri portable solar panel charging speeds could vary with different operating and environmental conditions as below:

- **Weather:** Solar panel could have lower outputs in a cold, cloudy, and rainy environment.
- **Positioning:** Solar panel could have lower outputs when they are not directly facing the sun.
- **Obstructions:** Solar panel could have lower outputs when placed under shade, behind other objects, or behind a window.
- **Dirts:** Solar panel could have lower outputs when dust, dirt or guano is covering the surface.
- **Physical damage:** Solar panel could have lower output when the panel is damaged due to external pressure, scratch, or mechanical shocks.

### Can the solar panel be used in any weather?

No, please use the solar panels in stable weather conditions. The optimal temperature range for normal use and storage of solar panels is -4°F to 149°F (-20°C to 65°C).

**Warning:**

DO NOT use solar panels during severe weather conditions, such as thunderstorms, strong winds, and hailstorms.

### Would that be an issue if my solar panel get a bit wet?

No, but to maximize the lifespan of the solar panel, please avoid getting it wet. You can use it again when it is fully dried.

### How to clean the panel surface?

Dust and dirt on the surface should be removed by using a soft brush. The remaining dust or dirt could be wipe by a damp cloth . If there is any guano or other adhesive on the panel, it should be removed as soon as possible from the surface to avoid a reduction in performance.

## Warranty and Registration of Your jeri 120W Portable Solar Panel

### Warranty Registration and Terms and Conditions

Congratulations on choosing your jeri by Clenergy. To ensure that you get the best performance from your purchase please read the following warranty terms and conditions, complete the registration form and keep it for your records.

Alternatively, Please go to [www.clenergy.com.au/solution-centre/service-centre/](http://www.clenergy.com.au/solution-centre/service-centre/) and create your profile and attach purchase details to your account.



If any problems arise, please contact the company or outlet you purchased your product from.

Please retain a copy of the warranty registration form and proof of payment for any future warranty claim.

### 12 Months Limited Product Warranty

Our goods come with guarantees under the Australian Consumer Law. You are entitled to a replacement or refund for a major failure and for compensation for any other reasonably foreseeable loss or damage. You are also entitled to have the goods repaired or replaced if the goods fail to be of acceptable quality and the failure does not amount to a major failure.

The benefits given by this warranty are separate to any other rights and remedies you may have under laws in relation to the goods or services to which this warranty relates.

Your Details	
Name	
Street Address	
Suburb	
Post Code	
State	
Contact Number	
Email	

Retailer's Details	
Name	
Street Address	
Suburb	
Post Code	
State	
Contact Number	
Email	

Note:

Clenergy warrants to the original purchaser ("Purchaser") of product(s) that the Product shall be free from defects in material and workmanship for a period of twelve (12) months from the date of purchase.

### **Clenergy will replace or repair the product during the warranty period and subject to the following conditions:**

- The product does not perform in accordance with its design specifications.
- The product fails during the warranty period as long as it is used correctly as per the user manual.
- During the warranty period, Clenergy will replace the faulty product if this is considered to be the most appropriate course of action.
- Any and all costs for repair or replacement outside the warranty period are the responsibility of the Customer.
- Clenergy holds stock in Australia expressly for the purpose of warranty repairs or replacements.
- If there are any questions or concerns regarding the conditions of this warranty, please write or email us at the address below.

### **The warranty does not apply if:**

- The warranty period is expired.
- Damage is caused by incorrect use including dropping or placement in water or exposure to excessive precipitation.
- The product has been altered or damaged.
- The product has been repaired or altered by non-accredited or unauthorised person.
- Found to have unauthorised modifications.

### **How to make a warranty claim**

If the product is suspected of having a defect that needs to be attended to, you should follow the process to make a claim as laid out below, if you are out of warranty, please contact Clenergy directly for assistance the contact details are the same regardless:

From the paperwork that was originally provided by your retailer, you will be able to determine if you are still covered by warranty and who to contact in case of a defect to the product.

Once you have identified who supplied the product you should contact them directly and they will arrange for an inspection of the unit and whether the product should be returned to Clenergy for an assessment.

If however you are unsure how to make a claim, or are out of the Warranty period or don't know who you purchased your Clenergy product through, then you can contact us at Clenergy Australia for support as detailed below.

Enquiries can be made by phone, letter, email or website portal as below.

**Note:**

To claim through website portal, please register an online account and then you can submit, manage and view your claim from the account.

**Phone:** +61 3 9239 8088

**Email:** [service@clenergy.com.au](mailto:service@clenergy.com.au)

[www.clenergy.com.au/solution-centre/service-centre/](http://www.clenergy.com.au/solution-centre/service-centre/)





Power Your Freedom

## A Clenergy Technologies Company

1/10 Duerdin St Clayton VIC 3168 Australia

### Global Contact Numbers

CN: +86 592 311 0088 | AU: +61 3 9239 8088 | JP: +81 45 228 8226  
DE: +49 (0) 40 3562 389 00 | TH: +66 (0) 2 277 5201 | PH: +63 977 840 7240

### Global Partners

UK: +44 (0) 1604 877573

 @ClenergyClub / @ClenergyAus  @Clenergy@  Clenergy\_global

 @jeri.clenergy  @jeri.clenergy  @jeri.clenergy

W: [www.jerifreedom.com.au](http://www.jerifreedom.com.au) E: [sales@clenergy.com.au](mailto:sales@clenergy.com.au)

MADE IN CHINA | DESIGNED IN AUSTRALIA