

**BESMOKEYV2
BESMOKEYV2BK**



Page 1 of 2

Cleaning Guide:

Spraying cleaning products on to electrical products is not recommended. It is important to ensure that switches are turned off before cleaning.

Do not use any cleaning sprays - only wipe down with damp cloth or rub with dry cloth. (Do not use an abrasive cloth as it may scratch the plastic).

Do not use harsh chemical cleaners as these can break down the plastic and cause it to crack.

Do not wash the cover plates in water over 60°C.



Bear Photoelectric Smoke Alarm

- Photoelectric Sensing Technology.
- Complies with AS 3786:2014+A 1 :2015+A2:2018.
- Main power source 220-240V AC 50 Hz.
- Secondary power source Suitable batteries: GP DC 9V carbon battery or PAKKO DC 9V carbon battery; or EVE DC 9V Lithium battery; or Raymax DC 9V Alkaline battery.
- Interconnection Max. 24 alarms (wired 150m maximum).
- 4 hard wired Terminals that accommodate 2 x 2.5mm² (A, E-Loop, N , I-connect) for hard wired applications.
- Surface Mount Base Plate with Large Cable Terminals.
- Suitable for Ceiling or Wall Mounting.
- Alarm volume ≥ 85dB(A) @ 3m complying with ISO8201 alarm pattern.
- Operating Temperature 0 °C to 40 °C.
- Ambient for installation: 5-95% Relative Humidity.
- Red LED Alarm Status Indication.
- Green LED AC Mains Power Indication.
- Insect Screen protects Sensing Chamber.
- Sleek Styling.
- 10 Year warranty.
- Warning - Not Suitable to Connect With BESMOKEY 10 Series.
- Standard colour is white. Black also stocked - please check availability.

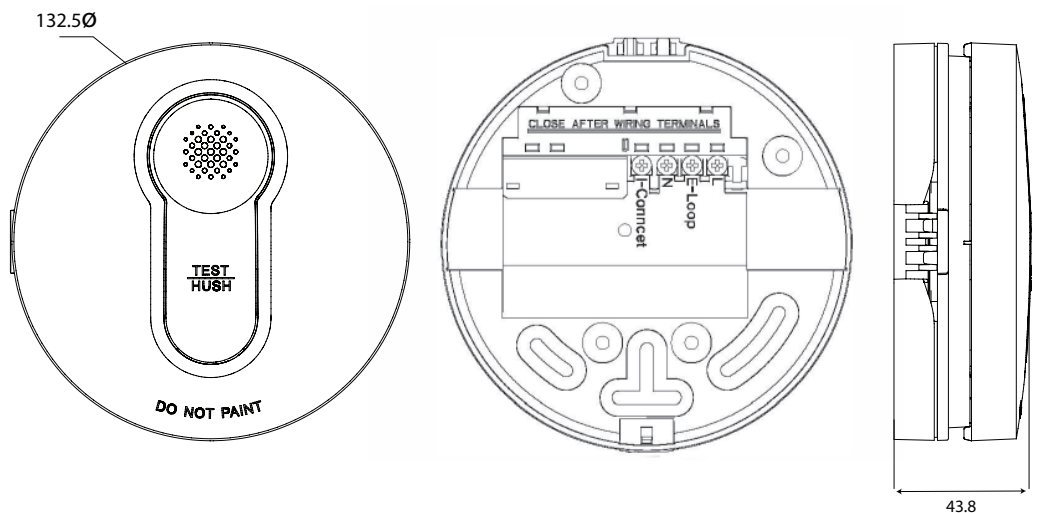

Catalogue Number	Description
BESMOKEYV2	Smoke Alarm Photoelectric Surface Mount, 220-240V AC, 9V Battery Backup, Individual or Interconnected
BESMOKEYV2BK	Smoke Alarm Photoelectric Surface Mount, 220-240V AC, 9V Battery Backup, Individual or Interconnected, Black

Certification Number:
SMK41382

GSM Electrical (Australia) Pty Ltd
Level 2, 142-144 Fullarton Road, Rose Park SA 5067
P: 1300 301 838 F: 1300 301 778 E: service@gsme.com.au
www.gsme.com.au



Standard: AS 3786-2014
Licence Number: SMK41282

Data Specification Sheet
231115

**BESMOKEYV2
BESMOKEYV2BK**



Page 2 of 2

Cleaning Guide:

Spraying cleaning products on to electrical products is not recommended. It is important to ensure that switches are turned off before cleaning.

Do not use any cleaning sprays - only wipe down with damp cloth or rub with dry cloth. (Do not use an abrasive cloth as it may scratch the plastic).

Do not use harsh chemical cleaners as these can break down the plastic and cause it to crack.

Do not wash the cover plates in water over 60°C.

Bear Photoelectric Smoke Alarm

Wiring Instructions:

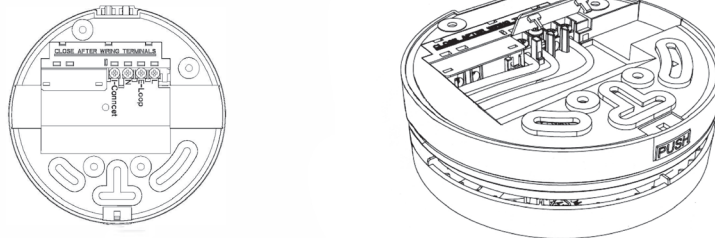

TERMINAL

- L** : **Live**
- E-Loop** : **Earth** 
- N** : **Neutral**
- I-Connect** : **Interconnection**

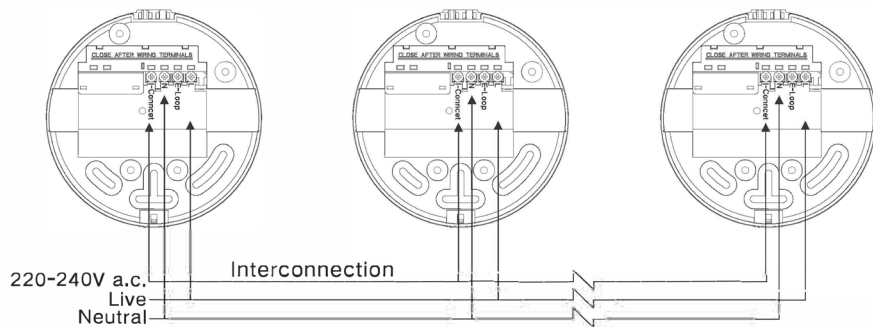

Replace Battery Instructions:

Note: After replacing battery press the TEST button to ensure it is connected and working correctly.

① Press the PUSH button



② Open the alarm body from base

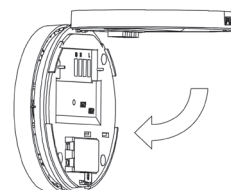

④ Close the alarm body.

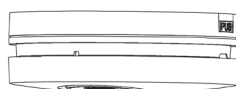

③ Replace a new battery

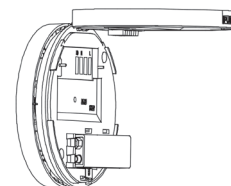

Certification Number:
SMK41382

GSM Electrical (Australia) Pty Ltd
Level 2, 142-144 Fullarton Road, Rose Park SA 5067
P: 1300 301 838 F: 1300 301 778 E: service@gsme.com.au
www.gsme.com.au



Standard: AS 3786-2014
Licence Number: SMK41282

Data Specification Sheet
231115