

# XLED signature series II

XS2040WLED



IK08



120°

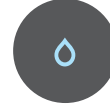

IP20



COLOUR  
TEMP. ADJUSTABLE



SURFACE  
MOUNTED

## DESCRIPTION

The XLED Signature Series II batten is a versatile LED diffused luminaire. The robust polycarbonate diffuser and metal body is designed for use in most dirty environments along with general confined areas and industrial applications. Dual wattage & tri-colour makes product selection all more simple.



## KEY INFORMATION

Model	XS2040WLED
Power (W)	20W/40W
Lumens (lm)	20W/1800lm 40W/3600lm
Construction	Body – Powder Coated White Steel Sheet Diffuser – Opal high impact polycarbonate Twist lock removable gear tray
Dimming Options	Non-dimmable
Fitting Colour	White
IP Rating (IP)	IP20/IK08
Lifespan (hrs)	50,000hrs
Dimensions	L1150mm x W65mm x H65mm
Mounting	Surface mounted
Control Gear	Integral electronic Non-Dimmable dual power LED driver

### Additional:

- 3 Years replacement warranty on fitting.

## PHOTOMETRIC DIAGRAM

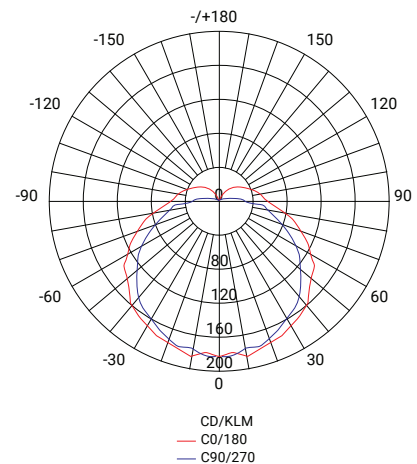

## PHOTOMETRIC DATA

Efficacy (lm/W)	≥88
CCT	3000K/4000K/5700K
CRI	>80
Beam Angle (°)	120°
Type LED	SMD Chips

## DIAGRAM(S)

