

Fig. 1: Front view

WBMDUPB
Push-button dimmer

Safety instructions

Electrical equipment must only be installed and assembled by a qualified electrician in accordance with the relevant installation standards, guidelines, regulations, directives, safety and accident prevention regulations of the country.

Failure to comply with these instructions may result in damage to the device, fire or other hazards.

Hazard due to electric shock. The device is not suitable for safe disconnection of the mains supply. Even when the device is switched off, the load is not isolated from the mains supply.

Do not connect non-dimmable lamps, their transformers or operating devices. Observe manufacturer's data.

These instructions are an integral component of the product and must be retained by the end user.

Design and layout of the device

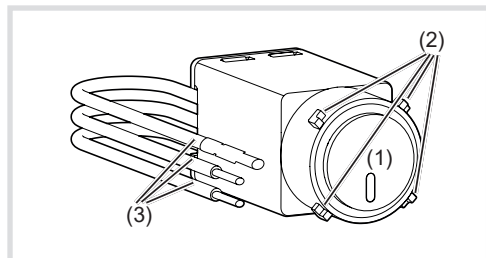

Fig. 1: Front view

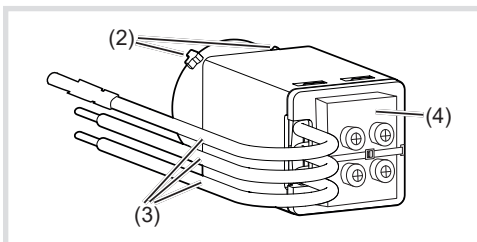

Fig. 2: Rear view

i The terminal block must be mounted in either its original shipped position or on the rear of the module by means of the enclosed cable tie.

- (1) Button with status LED
- (2) Retaining lugs for Rotoloc® fastening
- (3) Connection cables
- (4) Terminal block

Function

Correct use

- Switching and dimming of incandescent lamps, HV halogen lamps and dimmable 230 V LED lamps; electronic transformers with low voltage halogen lamps.
- Unsuitable for fans and motors
- Suitable for indoor use only, but no drip and no spray water.
- Suitable for Hager Rotoloc switch plates only

Product characteristics

- Phase cut-off dimmer with LED
- Wide, infinitely variable dimming range down to the lowest brightness for many lamps
- Programmable minimum brightness
- Additional configurable functions
- Automatic storage of the switch-off brightness level as switch-on brightness level
- Electronic short circuit, overload and thermal protection
- Multi-way dimming available only with use of the WBMSLL slave mechanisms
- Non volatile device settings

Control

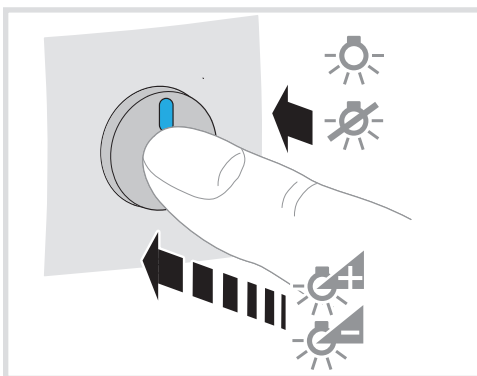

Fig. 3: Push-button dimmer operation

Load status	Action	Result
OFF	Short press of push-button	Switch ON with saved switch-on brightness level.
> 0%	Short press of push-button	Switch OFF and save brightness as switch-on brightness level.
> 0%	Long press of button	With every long push-button operation within 12 sec: Dimming with alternating direction, otherwise device will dim up, until max. level is reached.

Table 1: Push-button dimmer and slave unit operation

Adjusting the minimum brightness

The minimum brightness level can be adjusted with the push-button dimmer to prevent poor switch-on behaviour or flickering of the load in the lower dimming range.

- Switch off load.
 - Press and hold button for approx 10 seconds.
- The lamp and the status LED will flash once after 3 seconds and then both flash a second time after 10 seconds.
- Release push-button.

The device is now in minimum brightness setting mode. The status LED is flashing fast and the load is switched on at minimum brightness.

i Depending on the lamp, the minimum brightness level of the lights installed may be too low and the lights may appear off, gradually increase the brightness level by repeatedly pressing the button.

i If no actions are performed within 10 seconds, the dimmer exits programming operation.

- Briefly press the button repeatedly.
- The brightness increases gradually.
- Once desired min lighting level is reached, wait 10 seconds for device to store the setting.
- The load will be switched off, the dimmer returns to normal operation.

i If your minimum setting is set too high, wait for the device to exit programming mode and repeat the above programming procedure

Configurable additional functions

The additional functions can be configured by pressing the push-button dimmer for the required number of times.

Kick-start

A short voltage burst when lamp is initially turned on to support lamp start-up.

Reduced maximum brightness

A non-adjustable voltage reduction for suppressing flickering at maximum brightness.

Status LED

In factory state the status LED lights up only, if the lamp is switched on. As described thereunder it may be set to be permanently on.

Recovering the previous load state when power is restored after a power cut

The status of the load prior to power loss will be restored at power-on.

Configuring additional function

- From the off position, press & hold the button for approx 10 seconds or more.
- The status LED and the lamp will flash once after 3 seconds and then both flash a second time after 10 seconds.
- Release push-button.
- The device is now in minimum brightness setting mode. The status LED is flashing fast and the load is switched on at minimum brightness.
- Press and hold the button for 3 seconds until the lamp flashes once again and the status LED gets off.
 - Release push-button.
- The status LED starts blinking fast again.
- Select the additional program function required by pressing the button slowly, waiting for the load to flash after each press (selected from Table 2) before pressing again.
- After approx. 10 s without operation, the change of additional function is stored and the device switches to standard operation.

Configurable additional functions	Factory settings	Number of button pushes
Kick-start	OFF	1 x
Reduced maximum brightness	OFF	2 x
Status LED lights up only when ON	ON	3 x
Recovery of the load state when the power is restored	OFF	4 x

Table 2: Configurable additional functions

Reset to factory setting

- Press the button for approx. 10 sec. or more.
The lamp and the status LED will flash once after 3 seconds and then both flash a second time after 10 seconds.
- Release push-button.
The device is in fine adjustment mode for the minimum brightness level and the status LED starts flashing fast and the load is set to the minimum brightness level.
- Press button again for approx. 10 s or more
The lamp and the status LED will flash once after 3 seconds and then both flash a second time after 10 seconds.
- Release push-button
The status LED goes out and the reset has been completed, the dimmer is in standard operation with the factory settings being effective.

Information for electricians

Installation and electrical connection

⚠ DANGER!
Electrical shock when live parts are touched.
An electric shock can lead to death.
Isolate all power before working on the device and cover any live parts in the area!

Connection diagram

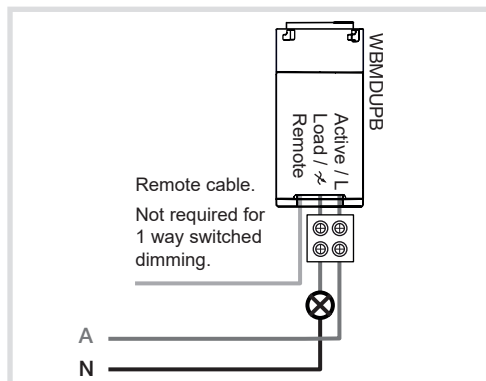

Fig. 4: 1 way connection

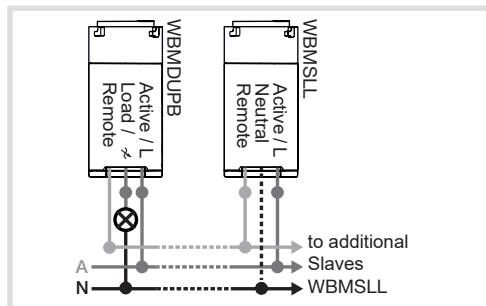

Fig. 5: 2 way connection

- Load side of device is not considered isolated in OFF position.

- Install a circuit breaker of max. 10 A as device protection.

- For 2 way or multiple way switching. Refer to WBMSLL instructions.

Appendix

Technical data

Operating voltage	230 V~ +/-10%
Frequency	50 Hz
Miniature circuit breakers	max. 10 A
Degree of protection	IP2X
Standby power consumption	
- Status LED off	< 0.07 W
- Status LED on	< 0.3 W
230 V incandescent lamps, halogen lamps and cold-light reflector lamps	7 ... 300 W
Dimmable, electronic transformers with low voltage halogen lamps	20 ... 350 W
Dimmable 230 V LED lamps	3 ... 250 W
Slave units cable length	
Load and slave unit cable	
- in one cable	max. 20 m
- in separate cables	max. 50 m
Terminal block cables	max. 2 x 1.5 mm ²
	max. 1 x 2.5 mm ²
Flying leads, flexible	100 mm x 1,5 mm ²
Operating temperature	-5 to 50 °C
Storage temperature	-20 to 70 °C
Relative humidity (without dewing)	0 ... 65 %
Packaged with 3 cores, flexible	100 mm x 1.5 mm ²

Operating conditions

Load type	Maximum output power (W)		
	25 °C	35	50 °C
Ohmic loads	300	265	210
Dimmable, electronic transformers with low voltage halogen lamps	350	310	250
230 V LED lamps	250	220	175

Table 3: Reduced performance, ambient temperature
When operating dimmers in combination with others beneath a cover plate, the maximum connected load must be reduced depending on the number of dimmers.

Number of dimmers per combination	Connect load reduction
1	100%
2	75%
3	55%
4	40%
5	35%
6	30%

Table 4: Dimmer combination load reduction

- Carry out loading of conventional, electronic transformers according to manufacturer's instructions.
- Do not use non-dimmable 230 V LED lamps.
- If 230 V LED lamps are used, the power supply to the dimmer can cause the lamp to glow slightly even when it is switched off.

Troubleshooting

Dimmer switches off of its own accord.

The electronic overload protection has tripped.

Check the load connected (excessive load).

Reduce the number of lamps or use lamps with a lower power rating.

The electronic short-circuit protection has tripped.

Check electrical installation.

The load cannot be dimmed down sufficiently.

The dimming angle is set too high.

Decrease the value in fine-setting of the minimum brightness.

The load switches off while being dimmed down.

The dimming angle is set too low.

Increase the value in fine-setting of the minimum brightness.

The load does not switch on.

The dimming angle and brightness value are set too low.

Increase the value in fine-setting of the minimum brightness.

Load flickers while switched off.

LED load too low.

Increase LED load at output.

The LED load flickers due to the dimmer status LED power

Switch off dimmer status LED

The connected load cannot be dimmed or load flickers while switched ON.

Lamps are not suitable for dimming.

Be sure always to use dimmable loads.

Undefined fault during operation.

Slave unit cable length is too long or no separate slave unit cable has been used.

Keep to slave unit cable length or, if necessary, use separate slave unit cable.

Note:

LED loads should be tested with this dimmer prior to installation. Some LED loads may not be compatible due to the type of LED driver within the LED light.



End of life treatment of electrical/electronic equipment and batteries in the European Union countries.

The crossed-out 'wheeled bin symbol' marked on the equipment or its packaging, indicates that this product is not to be disposed off with unsorted municipal / household waste. Please check with your local authority or retailer for recycling and collection advice. This will enable you to contribute to the disposal, treatment and recycling in an environmentally sound way and help to prevent potential negative effects on the environment and human health.