



Palm

The Palm is a LED recess-mount blade exit light with built-in side LEDs for emergency lighting coverage.



This product comes in a theatre variant as well (denoted by the order code BLK), which is perfect for use in darker environments.





Features

-  24m viewing distance
-  All directional decals included
-  LiFePO₄ Lithium Battery

Accessories

-  Green Decals: PIC-EX-BLADE
-  Black Decals: PIX-EX-BLADE-BLK

			
ORDER CODE	PALM-EM PALM-BLK-EM	PALM-ST PALM-BLK-ST	PALM-LR PALM-BLK-LR
WARRANTY	3 Years	5 Years	5 Years
TRADITIONAL DROP TEST	✓	✓	✓
APP SCHEDULED TESTING		✓	✓
REMOTE SCHEDULED TESTING			✓



Download the Elumen app



Device Specifications

OPERATIONAL INFORMATION

VOLTAGE	220 - 240VAC
FREQUENCY	50Hz
CRI	80
POWER CONSUMPTION	7W
RATED DURATION	> 2 hours
AMBIENT TEMPERATURE	1°C - 40°C
IP RATING	IP20
MOUNTING TYPE	Recessed Mount
OPERATING MODE	Maintained
CHARGER TYPE	Smart Charger
EMERGENCY LIGHT SOURCE LIFE	100,000 hours

CONSTRUCTION, DIMENSIONS AND WEIGHT

CONSTRUCTION	White Powder Coated Steel Body, Acrylic Decal
WEIGHT	2kg
CARTON QTY	8
CARTON DIMENSIONS	507mm x 410mm x 410mm
CARTON WEIGHT	19kg

COMPLIANCE AND TESTING

STANDARDS	AS/NZS 2293.3
	AS/NZS 60598.2.2
	AS/NZS CISPR 15
EMERGENCY CLASSIFICATION	C0: D32
	C90: D25

Product Drawing

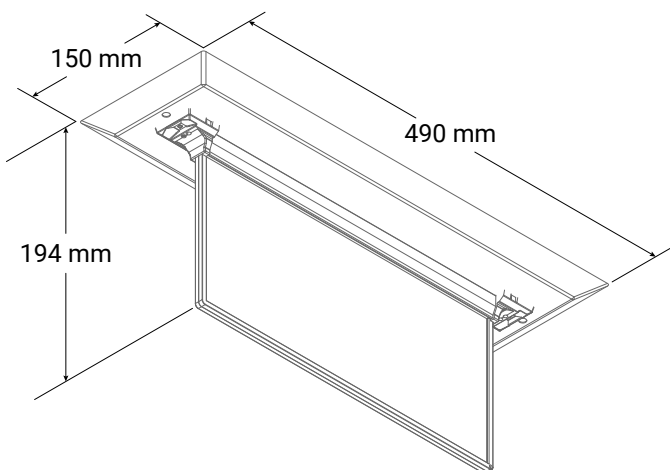

ORTHOGRAPHIC DRAWING