

# BH151ESW DOMINO

## 3-IN-1 BATHROOM SOLUTION



- 3 years **IN-HOME** warranty \*exclude lamps
- 2 years warranty for heat lamp
- High airflow extraction up to 500 m<sup>3</sup>/hr\*
- 1 x 800W heat lamps for instant heating
- 2 x 10W LED panel light
- Heavy duty metal housing provides durability
- Easy installation. Electrician friendly.
- Thermal safety protection
- Side ducted with draft stopper
- Cut-out template included\*\*

### EXHAUST

Motor Type	Ball Bearing Motor
Air extraction*	500 m <sup>3</sup> /hr
Motor wattage	60W
Duct Outlet Size	Ø150 mm

### LIGHT

Lamp Type	LED Panel
Globe wattage	2 x 10W
Lumens	1150lm
Colour Temp	3000K Warm White

### HEAT

Lamp Type	R7s Linear Heat Lamp
Globe wattage	1 x 800W
Colour Temp	2500K



### PAGKAGING

Packaging Size	650 x 476 x 280 mm
Packaging	Colour box
Gross Weight	9.1 kg
Net Weight	7.9 kg

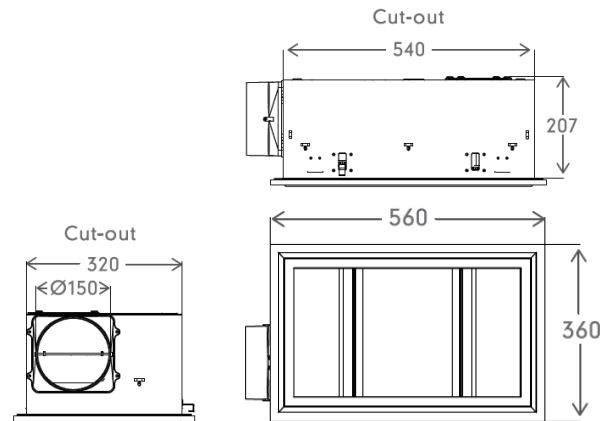

### INSTALLATION

Rated Input Voltage	220-240V~, 50Hz
Min Install Depth	235mm
Cut-out Size	540mm x 320 mm
Type of Connection	Hardwire
IP Rating	IP22

### INCLUDES

- 1 x 3-IN-1 Bathroom Solution
- 1 x 800W linear heat lamp
- 1 x 1.5m flexible aluminium duct
- 1 x 3 gang switch wall controller
- 2 x clamps for ducting
- 1 x external wall grille

### RECOMMENDED PARTS

Duct kit 1.5m model	DA15015D
Duct kit 3.0m model	DA15030D
R7 Heat Lamp 800W	XBH1514

SKU Model	Colour	Barcode	TUN Number
BH151ESWWH	White	9312699178474	(01)19312699178471
BH151ESWSL	Silver	9312699178481	(01)19312699178488
BH151ESWBK	Black	9312699154737	(01)19312699154734

\* Manufacturer supplied data. Actual performance may vary.

\*\* This product must be installed by a licensed electrician