



STAX ECO MULTI

Outdoor Floodlights

2POWER
Switchable
Modes

TRITONE
Colour
Changeable

IP66
Ingress
Protection
Rating

IK08
Impact
Rating

50,000hr
Expected
Lifetime

3yr
Warranty

Compact and flexible.

STAX ECO MULTI is a versatile and efficient LED Floodlight. With selectable colour temperature, dual power version and optional PIR motion sensor, it is suitable for a wide range of applications.

Features

- Tritone colour selectable
- IP66 weather resistant housing
- Easily adjustable
- Compact design
- PIR motion sensor available
- Corner mounting options

Benefits

- Reduced SKUs and inventory levels
- Robust and durable
- Simple maintenance and repositioning
- Suits most applications
- Added security and safety
- Installation freedom

Product Overview

POWER	LUMENS	EFFICACY	CCT	DIMENSIONS	WEIGHT	SAP CODE	PRODUCT CODE
15W	1720 lm	115 lm/W	4000K	140 x 178 x 26mm	0.6kg	2002130	STAX15W30W-TRI
	1850 lm	123 lm/W	5000K				
	1740 lm	116 lm/W	6000K				
30W	2710 lm	90 lm/W	4000K				
	3180 lm	106 lm/W	5000K				
	2960 lm	99 lm/W	6000K				
50W	5530 lm	107 lm/W	4000K	210 x 147 x 45mm	1.2kg	2002131	STAX50W-TRI
	5410 lm	108 lm/W	5000K				
	4730 lm	95 lm/W	6000K				

SPECIFICATIONS

Body Material:	Aluminium	Driver:	Integral
Diffuser Material:	Glass	Power Connection:	15/30W: 0.6m Flex 50W: 1m Flex
Body colour:	Black	Input:	220-240V, 50/60Hz
IP Rating:	IP66	Electrical Classification:	Class 1
IK Rating:	IK08	Power Factor:	>0.9
Beam Angle:	110°	Protection:	Overload / Short Circuit
Adjustable Angle:	0-180°	Lifespan:	>50,000hrs @Ta25°C (L70)
CRI:	>80	Operating Ambient Temperature:	-20 to 45°C
SDCM:	<5	Dimming:	Non-Dimmable

APPLICATIONS

Residential
Schools
Factories
Public Areas

ACCESSORIES

**90° Corner Mount Bracket
STAX90D-BRKT-S**
(SAP 2002136)
(Suits 20-50W models)



STAX15W30W-TRI



STAX50W-TRI

DIMENSIONS

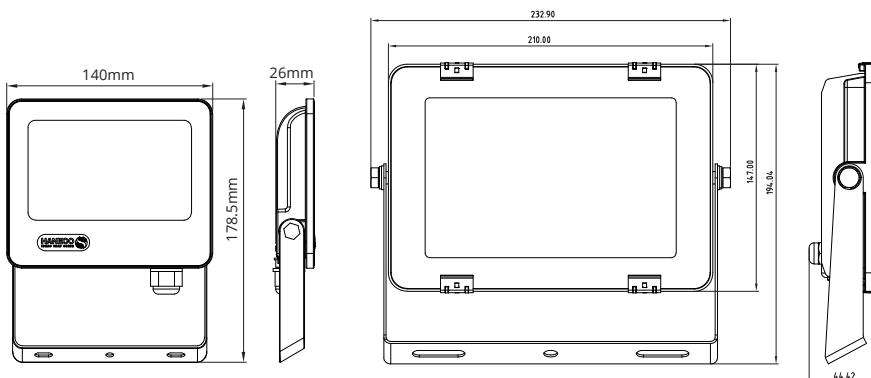

FIND OUT MORE:

