



MECHANISMS

AC, Printed, Electronic &
USB Charger Mechanisms

Data Specification **2020**



AUSTRALIA WIDE DELIVERY
Expedited delivery to all states in Australia



SAME DAY DISPATCH
Orders prior to 12PM will be dispatched the same day



5 YEAR WARRANTY
You can get a trusted 5 Year In House Warranty with CSG

[DESCRIPTION]

AC MECHANISMS

Connected Switchgear offers a variety of mechanisms to complement our range of socket outlets and wall switches - AC, data, phone, audio, and printed just to name a few. All Connected Switchgear mechanisms are interchangeable across our entire range of product.*

[FEATURES]

- Polycarbonate Material
- Brass Terminal Screws
- Silver/Nickel Switch Contacts
- Ratings of 250V AC 10AX, 16AX, 25A and 32A
- Available in Black and White
- Interchangeable with all Connected Switchgear switch plates*

[TECHNICAL PARAMETERS]

- Rated Voltage: 250V AC
- Rated Frequency: 50/60Hz
- Complies with:
AS/NZS 3100:2009
AS/NZS 3133:2013

[APPROVALS]

- SAA Approved

[IMAGES]



MHDMI



M25S



CAT6



M163P



M2W32F-OV



MNR



TVCP



MRCARR

*32A mechanisms are not compatible with B-POD10X BASIX Series Product.

[SPECIFICATIONS]

AC AND INDICATOR MECHANISMS			
Product Code	Rating (Amps)	Description	Colour
M2W10F	10AX	250V AC 1 Way/2Way	WHITE
M2W16F	16AX	250V AC 1 Way/2 Way	WHITE
M10DP	10AX	250V AC Mechanism Double Pole	WHITE
M20DP	20	250V AC Mechanism Double Pole	WHITE
M32DP	32	250V AC Mechanism Double Pole	WHITE
M10INT	10AX	250V AC Intermediate Switching	WHITE
M16BP	16AX	250V AC Bell Press Mechanism	WHITE
M25S	25	250V AC Split Mechanism	WHITE
M163P	16	250V AC 3 Position Rotary Mechanism	WHITE
M163P-K	-	3 Position Rotary Mechanism DOLLY ONLY	WHITE
MNR	-	250V AC Neon Indicator	RED
MNG	-	250V AC Neon Indicator	GREEN
M2W10FB	10AX	250V AC 1 Way/2Way	BLACK
M2W16FB	16AX	250V AC 1 Way/2 Way	BLACK
M10DPB	10AX	250V AC Mechanism Double Pole	BLACK
M20DPB	20	250V AC Mechanism Double Pole	BLACK
M32DPB	32	250V AC Mechanism Double Pole	BLACK
M10INTB	10AX	250V AC Intermediate Mechanism	BLACK
M16BPB	16AX	250V AC Bell Press Mechanism	BLACK
M25SB	25	250V AC Split Mechanism	BLACK
M163PB	16	250V AC 3 Position Rotary Mechanism	BLACK
M163PB-KB	-	3 Position Rotary Mechanism DOLLY ONLY	BLACK

[SPECIFICATIONS]

PRINTED MECHANISMS			
Product Code	Rating (Amps)	Description	Colour
M2W10F-Z1	10AX	250V AC 1 Way/2Way "ZONE 1"	WHITE
M2W10F-Z2	10AX	250V AC 1 Way/2 Way "ZONE 2"	WHITE
M2W10F-Z3	10AX	250V AC 1 Way/2 Way "ZONE 3"	WHITE
M2W10F-B1	10AX	250V AC 1 Way/2 Way "BEDROOM 1"	WHITE
M2W10F-B2	10AX	250V AC 1 Way/2 Way "BEDROOM 2"	WHITE
M2W10F-B3	10AX	250V AC 1 Way/2 Way "BEDROOM 3"	WHITE
M2W10F-FN	10AX	250V AC 1 Way/2 Way "FAN"	WHITE
M2W10F-HT	10AX	250V AC 1 Way/2 Way "HEAT"	WHITE
M2W10F-LT	10AX	250V AC 1 Way/2 Way "LIGHT"	WHITE
M2W16F-DN	16AX	250V AC 1 Way/2 Way "DAY/NIGHT"	WHITE
M2W32F-HP	32AX	250V AC Mechanism Double Pole "HOT PLATE"	WHITE
M2W32F-OV	32AX	250V AC Mechanism Double Pole "OVEN"	WHITE
M2W32F-RN	32AX	250V AC Mechanism Double Pole "RANGE"	WHITE
M2W32F-ST	32AX	250V AC Mechanism Double Pole "STOVE"	WHITE
M2W10FB-Z1	10AX	250V AC 1 Way/2Way "ZONE 1"	BLACK
M2W10FB-Z2	10AX	250V AC 1 Way/2 Way "ZONE 2"	BLACK
M2W10FB-Z3	10AX	250V AC 1 Way/2 Way "ZONE 3"	BLACK
M2W10FB-B1	10AX	250V AC 1 Way/2 Way "BEDROOM 1"	BLACK
M2W10FB-B2	10AX	250V AC 1 Way/2 Way "BEDROOM 2"	BLACK
M2W10FB-B3	10AX	250V AC 1 Way/2 Way "BEDROOM 3"	BLACK
M2W32FB-HP	32AX	250V AC Mechanism Double Pole "HOT PLATE"	BLACK
M2W32FB-OV	32AX	250V AC Mechanism Double Pole "OVEN"	BLACK
M2W32FB-RN	32AX	250V AC Mechanism Double Pole "RANGE"	BLACK
M2W32FB-ST	32AX	250V AC Mechanism Double Pole "STOVE"	BLACK

AUDIO VISUAL MECHANISMS

Product Code	Description	Colour
MHDMI	HDMI Mechanism with Nickel Plating	WHITE
MHDMIB	HDMI Mechanism with Nickel Plating	BLACK
MRCARB	RCA Recessed Mechanism	WHITE/BLACK ID
MRCARBB	RCA Recessed Mechanism	BLACK/BLACK ID
MRCARR	RCA Recessed Mechanism	WHITE/RED ID
MRCARRB	RCA Recessed Mechanism	BLACK/RED ID
MRCARW	RCA Recessed Mechanism	WHITE/WHITE ID
MRCARWB	RCA Recessed Mechanism	BLACK/WHITE ID
MRCARY	RCA Recessed Mechanism	WHITE/YELLOW ID
MRCARYB	RCA Recessed Mechanism	BLACK/YELLOW ID

DATA MECHANISMS

Product Code	Description	Colour
CAT3P	Cat 3 RJ11/12 Punch Down Type	WHITE
CAT5E	Cat 5E RJ45 Punch Down Type	WHITE
CAT6	Cat 6 RJ45 Punch Down Type	WHITE
CAT3PB	Cat 3 RJ11/12 Punch Down Type	BLACK
CAT5EB	Cat 5E RJ45 Punch Down Type	BLACK
CAT6B	Cat 6 RJ45 Punch Down Type	BLACK

TV MECHANISMS

Product Code	Description	Colour
TVCP	TV Connector 75Ohm to suit "Pay TV" - F Type to F Type	WHITE
TVSSF	TV Antenna Socket 75 Ohm - PAL to Screw Fix Solderless	WHITE
TVSFF	TV Antenna Socket 75 Ohm - PAL to F Type	WHITE
TVCPB	TV Connector 75Ohm to suit "Pay TV" - F Type to F Type	BLACK
TVSSFB	TV Antenna Socket 75 Ohm - PAL to Screw Fix Solderless	BLACK
TVSFFB	TV Antenna Socket 75 Ohm - PAL to F Type	BLACK

[WIRING DIAGRAM]

NEON INDICATOR MNR & MNG

One-Way Neon Indicator

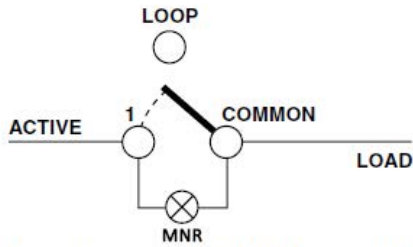

To wire neon "ON" when switch "OFF"

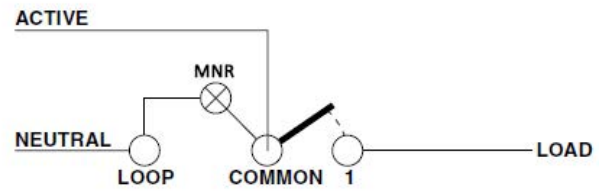

To wire neon permanently "ON"

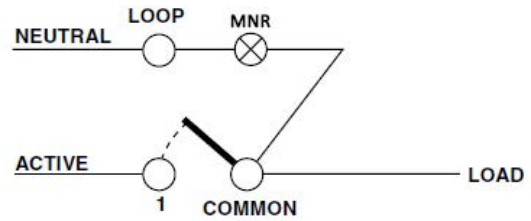

To wire neon "ON" when switch "ON"

One-Way/Two Way Neon Indicator

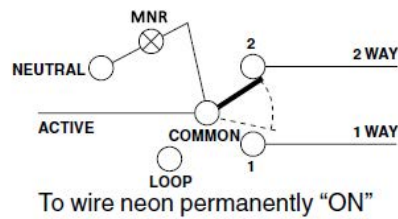

To wire neon permanently "ON"

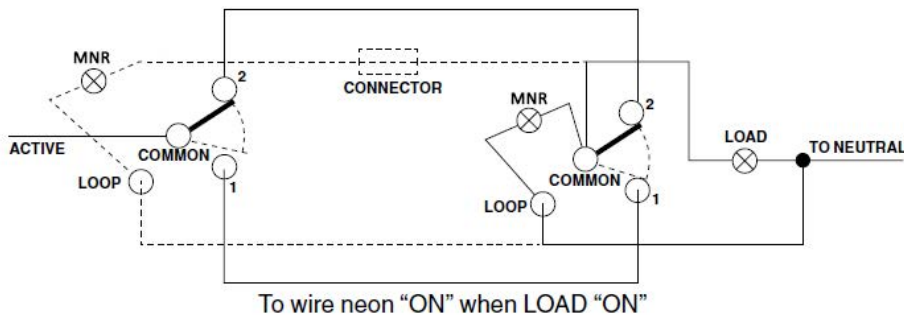

To wire neon "ON" when LOAD "ON"

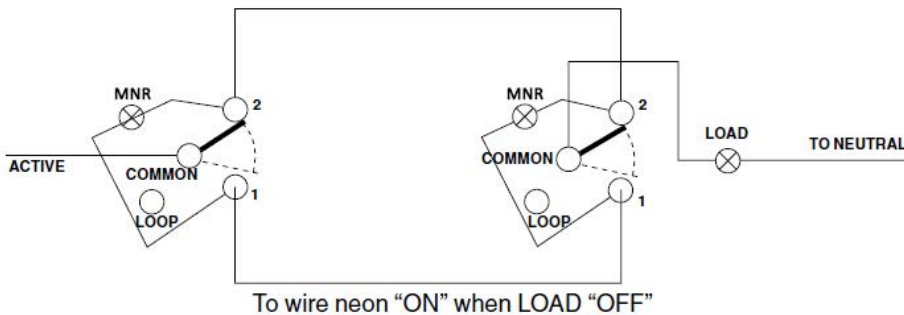

To wire neon "ON" when LOAD "OFF"

[DESCRIPTION]

ELECTRONIC SWITCH MECHANISMS

Connected Switchgear's range of electronic switch mechanisms are designed to give a modern look and feel across all series of grid plates and covers. Designed with a tactile switch and a blue LED indicator for ease of location in low light areas.

[FEATURES]

- Blue LED Indicator
- Available in Black and White
- Interchangeable with all Connected Switchgear Plates

[COMPATIBILITY]

- Non-dimmable LED lamps
- Incandescent Light Loads
- LV & MV Halogen Light Loads

[TECHNICAL PARAMETERS]

- Rated Voltage: 250V AC
- Rated Frequency: 50Hz
- Operating Temp: -10°C - 50°C
- Max Load: 350VA
- Min Load: 10VA*
- Complies with:
AS/NZS 60669.1:2013
AS/NZS 60669.2.1:2013

[APPROVALS]

- Global Mark Approved

[IMAGE]



MTS350



MTS350B

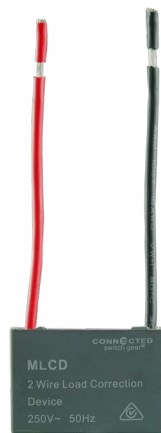

MLCD
(Optional)

*NOTE:

1. Certain applications may require a load correction device (MLCD) where a minimum load cannot be achieved.
2. In applications where the combined inrush current or load exceeds the rated current, a current limiting device is required to be installed.

[DESCRIPTION]

ELECTRONIC DIMMER MECHANISMS

Connected Switchgear's range of electronic dimmer mechanisms are designed to give a modern look and feel across all series of grid plates and covers. Designed with a tactile switch and a blue LED indicator for ease of location in low light areas. Operating as both on/off switch with dimming function and last position memory recall.

[FEATURES]

- Blue LED Indicator
- On/Off/Dim Function
- Last Dim Level Memory
- Available in Black and White
- Interchangeable with all Connected Switchgear plates

[COMPATIBILITY]

- Dimmable LED lamps
- Incandescent Light Loads
- LV & MV Halogen Light Loads

[TECHNICAL PARAMETERS]

- Rated Voltage: 250V AC
- Rated Frequency: 50Hz
- Operating Temp: -10°C - 50°C
- Max Load: 350VA
- Min Load: 10VA*
- Complies with:
AS/NZS 60669.1:2013
AS/NZS 60669.2.1:2013

[APPROVALS]

- Global Mark Approved

[IMAGE]



MTDM350



MTDM350B

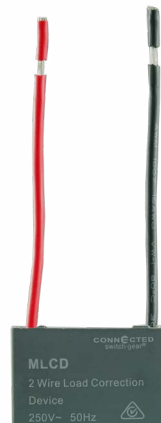

MLCD
(Optional)

*NOTE:

1. Certain applications may require a load correction device (MLCD) where a minimum load cannot be achieved.
2. In applications where the combined inrush current or load exceeds the rated current, a current limiting device is required to be installed.

[SPECIFICATIONS]

ELECTRONIC MECHANISMS				
Product Code	Min. Load	Max. Load	Type	Colour
MTS350	10VA	350VA	Electronic Switch	WHITE
MTDM350	10VA	350VA	Electronic Dimmer	WHITE
MTS350B	10VA	350VA	Electronic Switch	BLACK
MTDM350B	10VA	350VA	Electronic Dimmer	BLACK

[WIRING DIAGRAM]

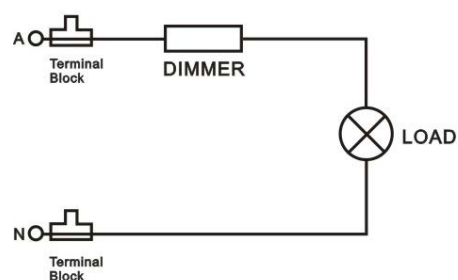
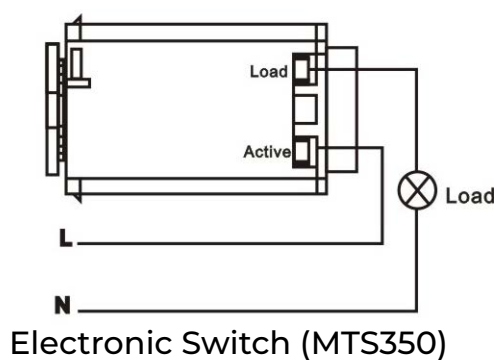

Electronic Dimmer (MTDM350)

[DESCRIPTION]

Connected Switchgear manufactures a variety of USB charger mechanisms and devices, from singular USB mechanisms to our latest fast charge dual USB charger with a maximum output of 6.2A 5V. The unique design allows for optional extension cables to a length of 2.4M that will allow the charging device to be placed separately to the USB mechanism outlet position. This allows installation in a wide variety of applications including those with limited space.

[FEATURES]

MUSB12

- Output 5V 1.2A
- Recharges All Electronic Devices Including Smart Phones & Tablets
- Interchangeable across all CSG plates*
- Available in Black & White

MUSB31R

- Fast Charge Capability
- Output 5V 6.2A (2 x 3.1A)
- Not Device Specific
- Optional 2.4M Extension Leads
- Interchangeable across all CSG plates
- Available in Black & White

[IMAGES]



MUSB12



MUSB31R



MUSB31LL

USB CHARGER MECHANISMS

[TECHNICAL PARAMETERS]

MUSB12

- Input Voltage: 100 - 240V AC
- Input Frequency: 50/60Hz
- Output Voltage: 5V DC
- Output Current: 1.2A
- Max Output Power: 5W
- Complies with: AS/NZS 60950.1:2015

MUSB31R

- Input Voltage: 220 - 240V AC
- Input Frequency: 50/60Hz
- Output Voltage: 5V DC
- Total Output Current: 6.2A
- Max Output Power: 2 x 3.1A
- Standby Power: 70mW
- Complies with: AS/NZS 60950.1:2015

[APPROVALS]

- Global Mark Approved

*MUSB12 is not compatible with POD10X, POD10X-L and SS-POD10X

[DESCRIPTION]

Connected Switchgear manufactures a variety of USB charger mechanisms and devices, now including a USB charger power outlet. The port is not specific meaning your phone or tablet can be plugged into either USB port to charge. With a total output of 3.1A at 5V it provides adequate power to charge a mobile device.

[FEATURES]

- USB Output 5V 3.1A
- Power Outlet 10A
- Dual USB Output - Not Device Specific
- Recharges All Electronic Devices Including Smart Phones & Tablets
- Available in White

USB INTEGRATED OUTLET

[TECHNICAL PARAMETERS]

- Input Voltage: 240V AC
- Input Frequency: 50/60Hz
- Output Voltage: 5V DC
- Output Current: 3.1A
- Max Output Power: 5W
- Complies with:
AS/NZS 3100:2009+A1-4
AS/NZS 3112:2011+A1-3
AS/NZS 60950.1:2015

[APPROVALS]

- SAA Approved

[IMAGES]



USB-POD10



USB-POD10

[SPECIFICATIONS]

USB CHARGER MECHANISMS			
Product Code	Type	Fast Charge Capable	Colour
MUSB12	USB Charger Mechanism 1.2A 5V	NO	WHITE
MUSB31R	Dual USB Remote Transformer 300mm Extension Leads 6.2A (2 x 3.1A) 5V	YES	WHITE
MUSB31LL	Dual USB Remote Transformer 2.4m Extension Lead ONLY	-	WHITE
MUSB12B	USB Charger Mechanism 1.2A 5V	NO	BLACK
MUSB31RB	Dual USB Remote Transformer 300mm Extension Leads 6.2A (2 x 3.1A) 5V	YES	BLACK
MUSB31LLB	Dual USB Remote Transformer 2.4m Extension Lead ONLY	-	BLACK
USB-POD10	Double Power Outlet with Integrated Dual USB Charger 240V AC 10A, USB 3.1A 5V	NO	WHITE

[WARRANTY]

Connected Switchgear mechanisms come with a trusted 5 Year In House Warranty. That means that you have peace of mind knowing that if a fault develops within a five year period, Connected Group Australia will cover the cost of replacing the product and it's installation.*

* See our website for full terms and conditions www.connectedswitchgear.com.au

[RELATED PRODUCTS]



PB1-L with MTDM350



POD10X-L

In various applications where it is not possible to position the dual USB transformer pack behind the wall plate/socket outlet, the optional 2.4m extension lead (MUSB31LL) allows for the transformer to be located in a more convenient location.



MUSB31LL

The additional switch mechanism is removable in all of our double socket outlets, allowing replacement with AC, electronic or USB mechanisms.