

### FEATURES

- ✓ 100dB @ 6W @ 1m
- ✓ Clear and intelligible audio performance
- ✓ Stylish and unobtrusive design with metal grill
- ✓ Simple power settings
- ✓ Compact and high strength fire resistant ABS plastic
- ✓ Flush-mounting system for fast and easy installation
- ✓ Environmentally friendly
- ✓ IP21C rated
- ✓ Shallow depth of 76.5mm (70mm recess)
- ✓ Light weight at 660 grams
- ✓ Easy knockouts for quick cable entry
- ✓ Compliant to latest NCC (National Construction Code) requirements
- ✓ Available in white or black
- ✓ Complying with AS7240.24-2015 & EN54-24 TYPE-A
- ✓ SAI Global Certified



### PRODUCT DESCRIPTION

The FS-SP4-7240 is a compact recessed ceiling loudspeaker, designed specifically for the Australian Public Address and Voice Alarm (PA-VA) markets.

High audio quality, low profile design and AS ISO 7240.24 certification for flush and surface mount installations, the FS-SP4-7240 is ideal for a wide range of applications. The broad and dynamic frequency response makes the speaker suitable for both music and speech reproduction.

The FS-SP4-7240 has low harmonic distortion and excellent sustention of high sound pressure level at all power settings, enabling the loudspeaker to provide accurate and intelligible broadcasting of evacuation and PA messages. The loudspeaker's modern and unobtrusive low-profile design makes it an ideal loudspeaker for indoor use such as offices, shopping centres, schools, hospitals, hotels and restaurants.

The FS-SP4-7240 is certified to AS ISO 7240.24 for flush mount and uses the same speaker for the surface mount installation, making it cost effective and compliant to the latest National Construction Code (NCC) requirements. It meets the SPL requirements of the NCC for residential applications achieving 100dB SPL compliance.

Easy to use adjustable power tapings and an enclosed terminal block facilitate your installation.

The custom spring fit system of the FS-SP4-7240 allows for easy removal without the risk of damaging sensitive ceilings/tiles. Having a low profile of 76.5mm (70mm recess) also makes the loudspeaker easy to install, even in challenging ceiling areas with limited ceiling space.

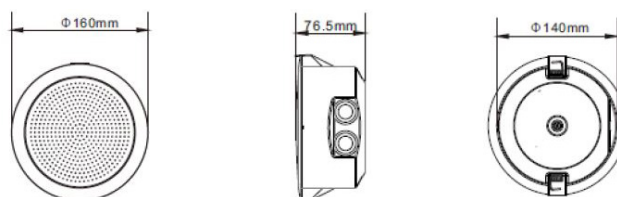

### INSTALLATION/CONFIGURATION

1. Cut out a 140mm hole using a 140mm FireSense Holesaw, or equivalent.
2. Pull cables through 140mm cutout.

*For Steps 3 and 4, please refer to the images below.*

3. Knockout either 1 or 2 of the plastic knockout discs, depending on number of cables to that specific speaker. Hit the knockout disc with a screwdriver to release the knockout disc.
4. Install 1 or 2 of the rubber grommets into place, making sure they are fitted securely all the way around the edges of the knockout.



6. Make a small hole in rubber grommet for cable entry.
7. Terminate cables to COM / 100V line terminals. (If the speaker is at the end of the run, terminate to COM / 100V on one side, and fit appropriate EOL on the other side).
8. Check and adjust speaker tapings, as required for installation (default setting is 0.375w).
9. Refit encapsulated back housing ensuring the alignment tab lines up to create a tight seal.
10. To fit in ceiling, hold spring tension clamps up against the housing and insert speaker into the 140mm cutout.

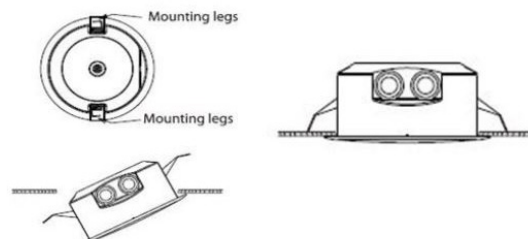

*(Note: the spring tension clamps are suitable for ceilings which have a thickness of 9mm to 25mm and are fitted with rubber boots to reduce soft ceiling tile damage. Ceilings which use a perforated steel grill type panel (less than 5mm) may require extra backing support to increase spring tension and reduce the risk of speaker sag over time).*

**TECHNICAL SPECIFICATIONS**

Rated Power	6W, (maximum power 9W), 100V line transformer
Transformer Power Taps	0.375W (default), 0.75W, 1.5W, 3W, 6W
Sensitivity	91dB ± 2dB @ 1W, 1m, 100V, 100Hz-10kHz
Maximum SPL	100.5dB @ 6W, 1m, 100V, 250Hz-20kHz 106.5 dB @ 6W, 0.5m, 100V, 250Hz-20kHz
Effective Frequency Response	200Hz-15kHz
Frequency Response	200Hz-15kHz (speaker installed w/ surface mount box) (±2dB)
Speaker Driver Unit	100mm (4")

**MECHANICAL**

Dimensions - Recessed Mount	Ø 160mm x 75mm D (Recess 70mm)
Dimensions - Surface Mount	Ø 280mm x 75mm D
Weight	0.66kg
Ceiling Cut-Out	140mm Ø
Colour	White RAL 9003 / Black RAL 9004
Material	Housing (ABS), Grill (Powdercoated Steel), Surface Mount Box (ABS)

**ENVIRONMENTAL**

IP Rating	Type A (AS7240.24) / IP21
Operating Temperature	-25°C to +55°C
Storage Temperature	-40°C to +70°C
Relative Humidity	<95%

**OPTIONS**

FS-SP4-SMB-7240	Surface mount enclosure to suit FS-SP4-7240
FS-SP4-7240-BK	100mm ceiling speaker with metal grill - Black
FS-SP4-SMB-7240-BK	Surface mount enclosure to suit FS-SP4-7240 - Black

#### CIRCUIT DIAGRAM

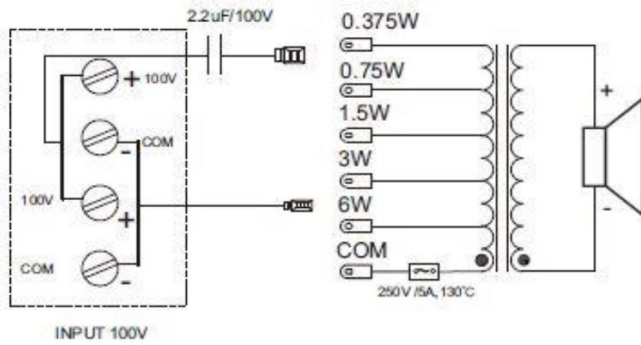

#### SPL / FREQUENCY GRAPH - 1W, 1M, 100V

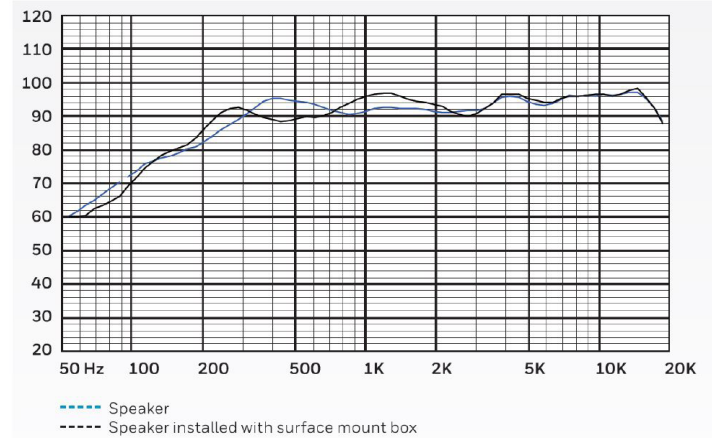

#### SPL / FREQUENCY GRAPH - 3W, 1M, 100V

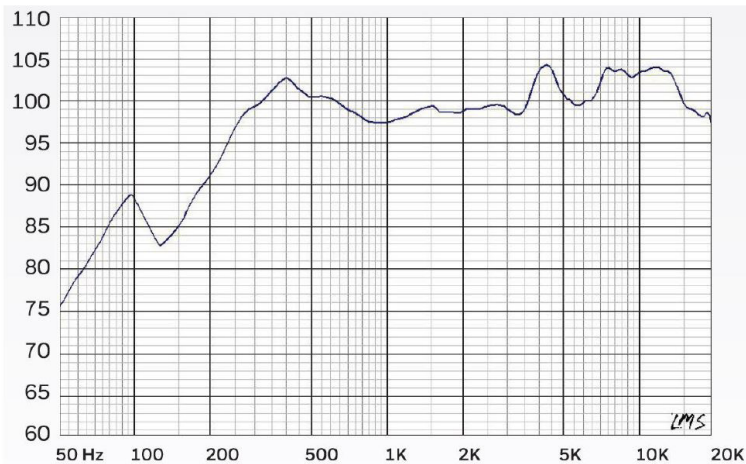

#### APPROVALS

- ✓ This speaker complies with AS/ISO7240.24.
- ✓ SAI Global: Certificate No. SMK40640 (refer to certificate for compliance)