

**PUSWV1G**  
**PUSWV2G**  
**PUSWV3G**  
**PUSWV4G**  
**PUSWV5G**  
**PUSWV6G**  
**PUSW1G**  
**PUSW2G**  
**PUSW3G**  
**PUSW4G**  
**PUSW5G**  
**PUSW6G**

\*See current catalogue for further detail

**Cleaning Guide:**

Spraying cleaning products directly on to electrical switches or power points (sockets) is not recommended.

It is important to ensure that switches are turned off before cleaning.

Do not use any cleaning sprays - only wipe down with damp cloth or rub with dry cloth. (Do not use an abrasive cloth as it may scratch the plastic)

Do not use harsh chemical cleaners as these can break down the plastic and cause it to crack.

Do not wash the cover plates in water over 60°C.



## Puma Range of Switch Plates

- Switches are rated 10AX/16A 250V~ and approved to AS/NZS3133
- Fits standard Australian wall boxes and mounting accessories that use 84mm mounting centres
- Uses brass tunnel terminals that have the screws backed out for easier installation of cabling. Switches are two way with looping terminal and suit 4 x 1.5mm<sup>2</sup> cabling with 4.1 bore
- Slotted head screws for the terminals
- Covers, plates and dollies are made from UV stabilised polycarbonate to avoid discolouring to yellow
- Standard colour is white. Black also stocked - please check availability
- Typical example of size seen below:

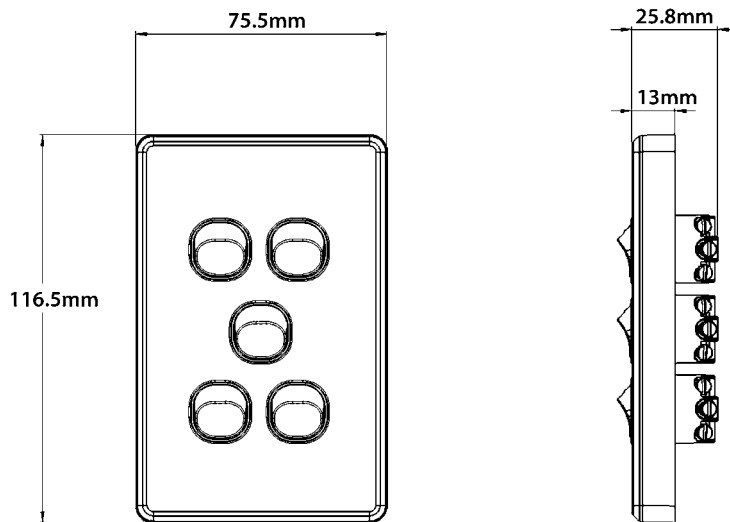

Catalogue Number	Description
PUSWV1G	Switch Vertical 1 Gang, 10AX/16A 250V~
PUSWV2G	Switch Vertical 2 Gang, 10AX/16A 250V~
PUSWV3G	Switch Vertical 3 Gang, 10AX/16A 250V~
PUSWV4G	Switch Vertical 4 Gang, 10AX/16A 250V~
PUSWV5G	Switch Vertical 5 Gang, 10AX/16A 250V~
PUSWV6G	Switch Vertical 6 Gang, 10AX/16A 250V~
PUSW1G	Switch Horizontal 1 Gang, 10AX/16A 250V~
PUSW2G	Switch Horizontal 2 Gang, 10AX/16A 250V~
PUSW3G	Switch Horizontal 3 Gang, 10AX/16A 250V~
PUSW4G	Switch Horizontal 4 Gang, 10AX/16A 250V~
PUSW5G	Switch Horizontal 5 Gang, 10AX/16A 250V~
PUSW6G	Switch Horizontal 6 Gang, 10AX/16A 250V~

**Horizontals available by request**

**Certification Number:** GMA-103194-EA-011

**GSM Electrical (Australia) Pty Ltd**

Level 2, 142-144 Fullarton Road, Rose Park SA 5067

P: 1300 301 838 F: 1300 301 778 E: service@gsme.com.au

[www.gsme.com.au](http://www.gsme.com.au)

