

PUSWVA1G
PUSWVA2G

*See current catalogue for further detail

Cleaning Guide:

Spraying cleaning products directly on to electrical switches or power points (sockets) is not recommended.

It is important to ensure that switches are turned off before cleaning.

Do not use any cleaning sprays - only wipe down with damp cloth or rub with dry cloth. Do not use an abrasive cloth as it may scratch the plastic.

Do not use harsh chemical cleaners as these can break down the plastic and cause it to crack.

Do not wash the cover plates in water over 60°C.



Puma Range of Architrave Switches

- Switches are rated 10AX/16A 250V~
- Uses brass tunnel terminals that have the screws backed out for easier installation of cabling. Switches are two way with looping terminal and suit 4 x 1.5mm² cabling with 4.1mm bore
- Slotted head screws for the terminals
- Covers, plates and dollies are made from UV stabilised polycarbonate to avoid discolouring to yellow
- Standard colour is white.
- Approved to AS/NZS3133
- Typical example of size seen below:

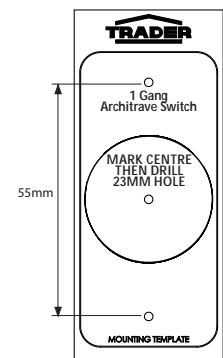
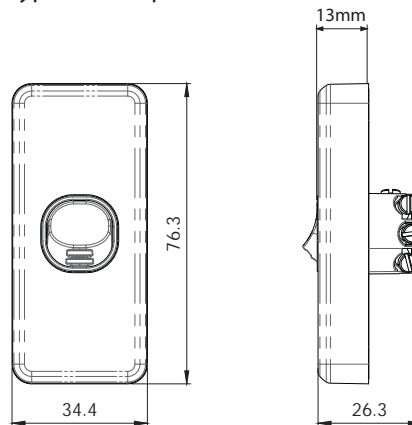

example of cutting template supplied

PUSWVA1G

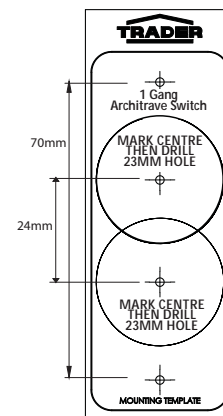
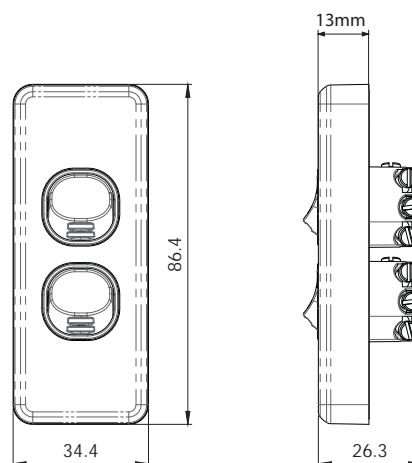

example of cutting template supplied

PUSWVA2G

Catalogue Number	Description
PUSWVA1G	Switch Vertical Architrave 1 Gang, 10AX/16A 250V~
PUSWVA2G	Switch Vertical Architrave 2 Gang, 10AX/16A 250V~

MEERKAT

MEERKAT Switch Mechanisms are used for all switch plates. Please refer to Meerkat Mech Matrix for range compatibility.

Certification Number: GMA-508434-EA

GSM Electrical (Australia) Pty Ltd

Level 2, 142-144 Fullarton Road, Rose Park SA 5067

P: 1300 301 838 F: 1300 301 778 E: service@gsme.com.au

www.gsme.com.au



Data Specification Sheet
January 2020