



Twin LED Spotlight

CAT NO. 659515LI, 659516LI



Cat No	659515LI	659516LI
Type	SPU	Axiom
Battery Pack	Liion 12.8V 3.2Ah	
Operating Voltage	240 V a.c +/- 6% 50 Hz	
Operating Mode	Non-maintained	
Energy Consumption	5W	
Body Constructions	Polycarbonate	
Operating Temperature	10°C to 40°C	
Lumen Output	2 x 580lm	
IP Rating	IP65	
IK Rating	IK07	
Compliance	AS/NZS2293.3 AS/NZS60598.2.22  	

Twin LED Spotlight

CAT NO. 659515LI, 659516LI



- LED Spotlight for non-maintained emergency lighting applications.
- Ideal for commercial applications such as car parks and sports venues.
- Energy efficient LED lamp technology.
- iSmart™ temperature sensing technology for the LIION battery.
- Electronics designed to lengthen the life of the battery, minimizing maintenance costs.
- Environmentally friendly battery.
- Easy to install.
- SPU or Axiom options.
- 5 Year Warranty.
- Designed and Manufactured in Australia.

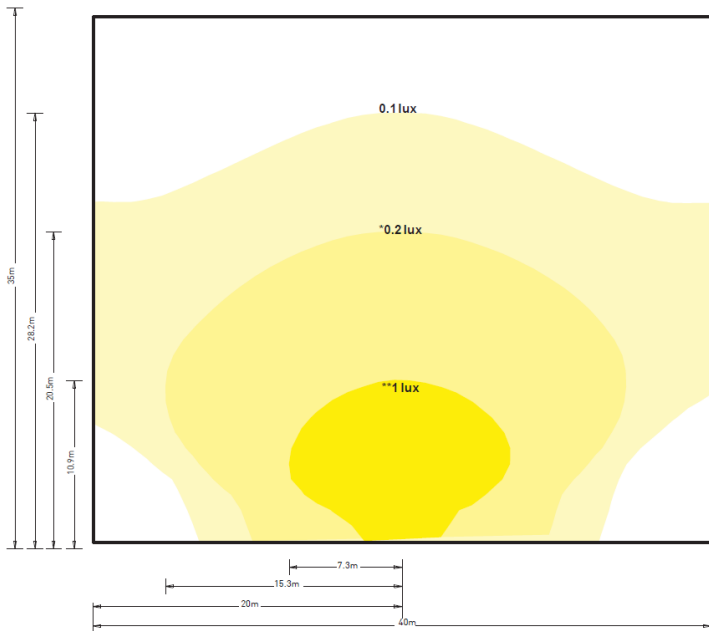

- Luminaire is mounted @5m above floor on one wall.
- Spotlights have a 90 degree tilt angle (straight out from fitting)
- A maintenance factor of 1.0 is applied to all luminaires.
- Illuminance measurements are at groundlevel.
- This design is to be used as a guide only and should not be used for compliance. A dedicated lighting design will need to be done for every application.

*0.2lux corresponding to Australian lighting standards.
 **1.0lux corresponding to New Zealand lighting standards.

DIMENSIONS

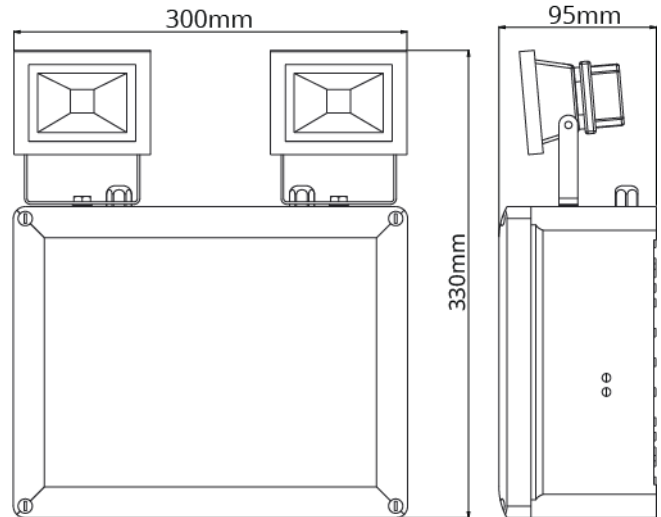

With Wire Guard

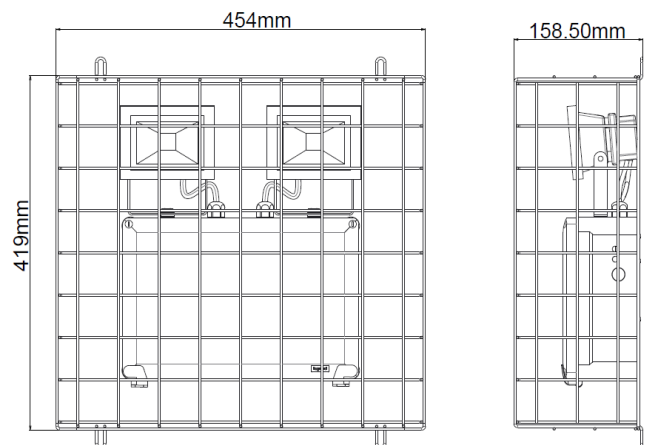

Cat No.	Description
SPU	
659515LI	Twin LED Spotlight IP65 Lithium
Axiom	
659516LI	Twin LED Spotlight IP65 Lithium
Accessory	
682369	Wire Guard - White

Legrand Australia
 1300 369 777
www.legrand.com.au
 ABN 31 000 102 661

Legrand New Zealand
 0800 476 009
www.legrand.co.nz

Refer to your group buying office, Legrand Sales Representative or Legrand Sales Office for pricing.

Please note: specifications are subject to change without prior notice.