

# 75w IP20 Indoor LED Strip Driver

## PRODUCT SPECIFICATIONS

**Material:** Plastic

**Colour:** White

**Input Voltage:** 240v AC

**Output Voltage:** 12v DC or 24v DC

**Output Power:** 75w\*

**Wiring:** Parallel

**IP Rating:** IP20

**Dimmable:** No

**Warranty:** 2 Years Replacement\*\*



Supplied with Flex & Plug

## COMPATIBLE WITH

LED Strip

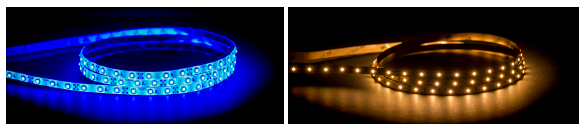

## DIMENSIONS

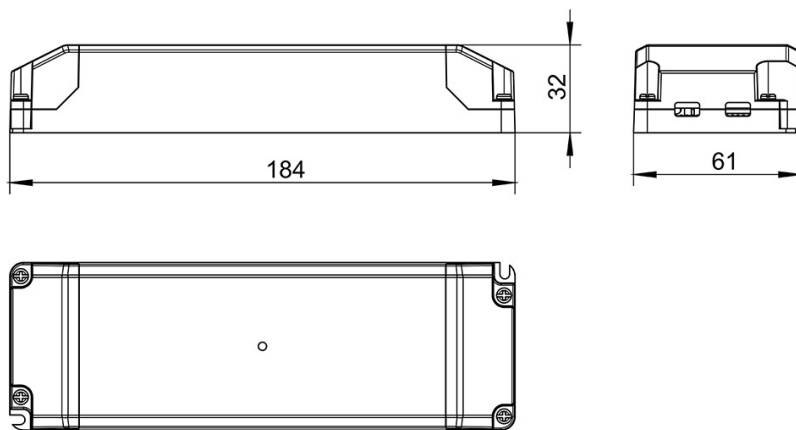

## IP RATING



## APPROVAL



## Product Ordering

IMAGE	OUTPUT VOLTAGE	PART NUMBER
	12v DC	HV9667-12V75W
	24v DC	HV9667-24V75W

## SAMPLE INSTALLATION DIAGRAM

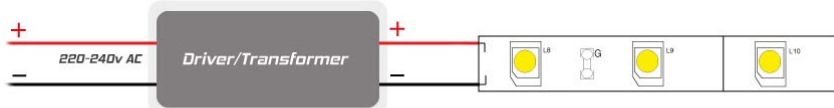

\* Recommended maximum Load of 60w

\*\* See Warranty Terms and Conditions for more information

For more information contact Havit Lighting

ADDRESS:  
143 Beauchamp Road  
Matraville NSW 2036  
Australia

Tel: 02 9381 8300  
Fax: 02 9666 8881  
Email: sales@havit.com.au  
web: www.havit.com.au

# 75w IP20 Indoor LED Strip Driver



Output	DC Voltage	12V	24V
	Voltage Tolerance	±0.5V	
	Voltage Regulation	± 0.5%	
	Rated current	6.3A	3.1A
	Rated power	75W	75W
Input	Voltage Range	220-240V AC	
	Frequency range	47 - 63HZ	
	Power Factor (Typ.)	PF≥0.95 (Full loading)	
	Full Load Efficiency(Typ.)	88%	89%
	AC Current(Max.)	0.52A	
	Leakage Current	<0.50mA	
Protection	Short Circuit	Hiccup mode, recovers automatically after fault condition is removed	
	Over Load	≤120% shut down o/p voltage, re-power on to recover after fault condition is removed	
	Over Temperature	100°C ± 10°C shut down o/p voltage, re-power on to recover	
	Protection Class:	II	
Environment	Working temperature	40 - +60°C	
	Working humidity	20 - 90%RH,non-condensing	
	Storage temp. and humidity	-40- + 80°C, 10-95%RH	
	Temp. coefficient	±0.03%/°C ( 0-50°C)	
	Vibration	10-500Hz,2G 12min./1 cycle,period for 72min.each along X.Y.Z axes.	
Safety and EMC	Safety standards	EN61347-1 EN61347-2-13 IP20	
	Withstand voltage	I/P-O/P:3.75KVAC I/P-FG:1.88KVAC O/P-FG:0.5KVAC	
	Insolation resistance	I/P-O/P I/P-FG O/P-FG:100MΩ/500VDC/25°C/70%RH	
	EMC Emission	EN55015,EN61000-3-2,3 (>60%loading)	
	EMC Immunity	EN61000-4-2,3,4,5,6,11,EN61547, A light industry level (Surge 4KV)	

For more information contact *Havit Lighting*

ADDRESS:  
143 Beauchamp Road  
Matraville NSW 2036  
Australia

Tel: 02 9381 8300  
Fax: 02 9666 8881  
Email: [sales@havit.com.au](mailto:sales@havit.com.au)  
web: [www.havit.com.au](http://www.havit.com.au)