

Swivelpole™ S3 M1

Stanchion or Stanchion & Structure Mounted

2.4 – 3m

Industrial

Guardrail Solution

S3 M1

Top

DN40

Base

DN40

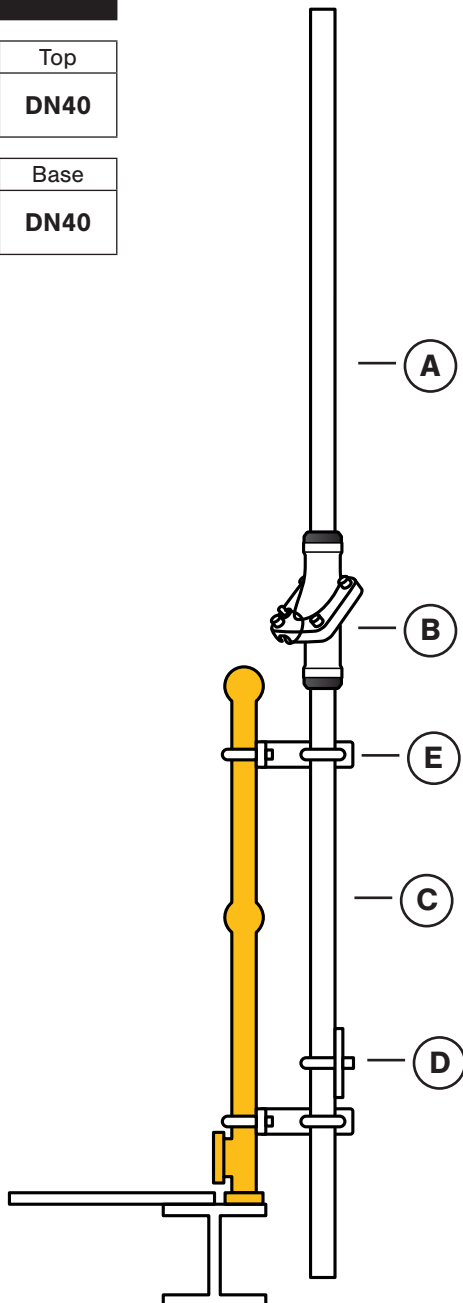

Designed for installation in accordance with IEC standards

Overview

A Pole Top Section

B Maxis™ joint

C Pole Base Section

D Junction Box Plate (optional)

E Mounting Brackets (optional)

Aluminium Option

Light weight - reduced stress on stanchion, corrosion free, cost effective, suitable for all wind regions.

Applications

Ideal for lighting on walkways, platforms, stairways, spiral stairways, conveyors.



Scan Code with QR Reader App for more information on Swivelpole™ S3 M1.

Product Coding Logic

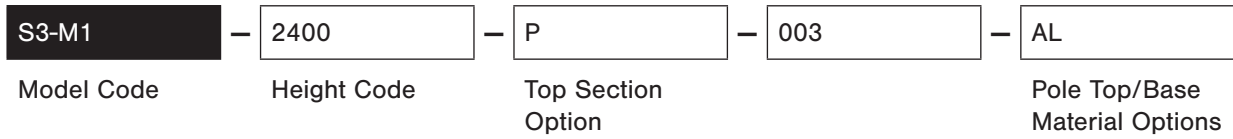

Heights

Height Code	Installed Heights (Nominal)
2400	2.4 m ▶
3000	3.0 m ▶

Specified Loads

Max Combined Weight
20 kg
20 kg

Top Section Options

P	Plain Pole Top
---	----------------

Material Options

Maxis™ joint - Steel / Zinc Aluminium Coating*	
HG	Steel / Hot-Dip Galvanised
AL	Aluminium

*Zinc Aluminium is suitable with hot-dip galvanised or aluminium

Related Components

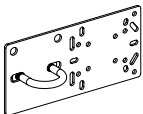
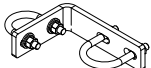
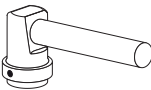
<p>Junction Box Plate for safe and efficient installation and termination.</p>		p. 48
<p>Mounting Brackets available to suit various stanchion types.</p>		p. 45
<p>Luminaire & Equipment Mounts to suit popular light fixtures (luminaire) and equipment.</p>		p. 47