

EXTENDED VERTICAL WALL (UNDER EAVE) MOUNT

SUITS: SDJ6502 65CM SATELLITE DISH

PRODUCT CODE: SBSEWV



INSTALLATION OPTION 1:
MOUNTING THE MAST POLE
ON THE "OUTSIDE" OF THE
ANGLED MOUNTING BRACKETS

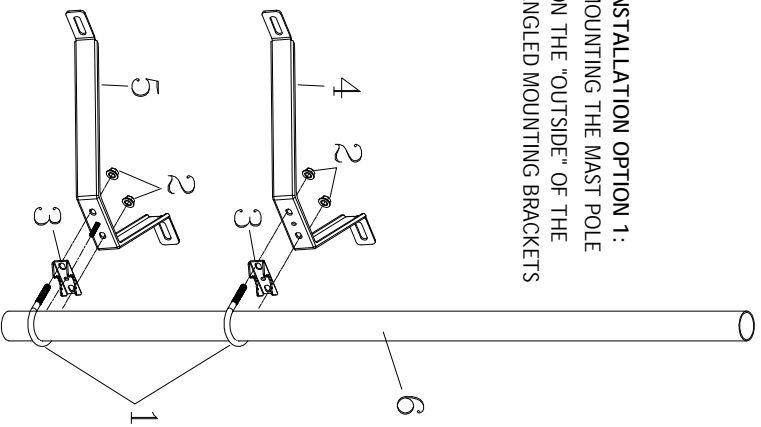

INSTALLATION OPTION 2:
MOUNTING THE MAST POLE
ON THE "INSIDE" OF THE
ANGLED MOUNTING BRACKETS

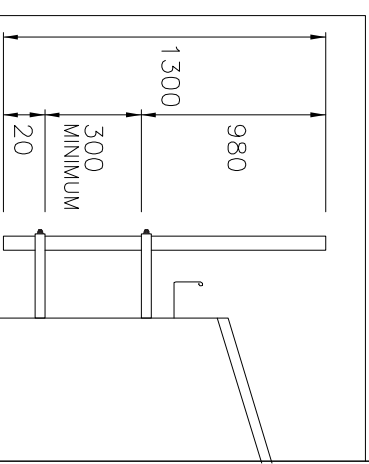
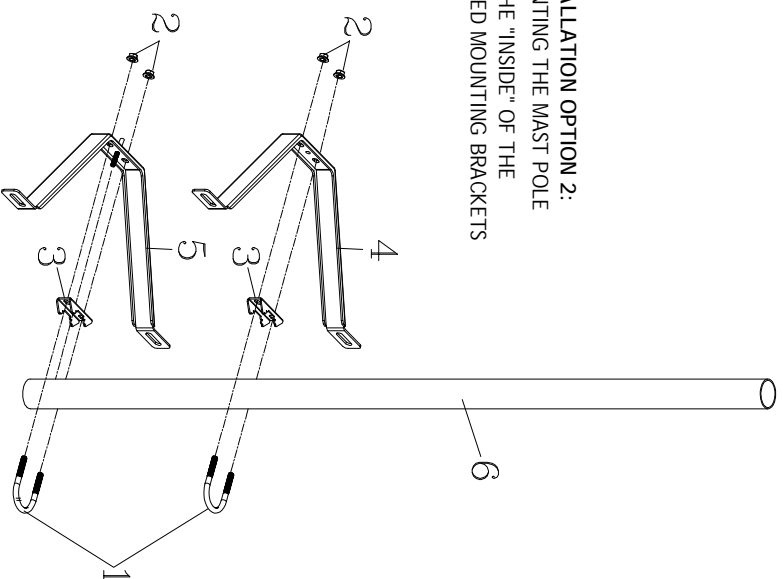

450 mm WIDE WITH ELONGATION
SLOTS FOR EASE OF MOUNTING

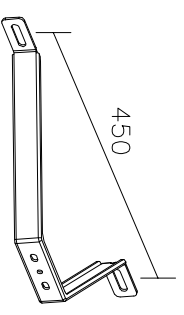

NO.	ITEM	DESCRIPTION	Q'TY
6		Mast Pole $\phi 45 \times L1300$	1
5		Lower Bracket with a Pin	1
4		Upper Bracket	1
3		U-Bolt Clamp	2
2		M8 Hex Flange Nut	4
1		M8*W46 U-Bolt	2

REVISION - SBSEWV:02052019 V2

A45100-0001

SBSEVW INSTALLATION INSTRUCTIONS:

STEP 1 - (Lower Bracket with Pin #5) Pre-assemble the lower bracket (#5) using one U-bolt clamp (#3) and two flange nuts (#2) to the mast pole (#6). Ensure the location pin on the lower bracket (#5) is correctly aligned and inserted into the hole of the mast pole (#6). Secure the lower bracket (#5) to the mast pole (#6) by tightening the two flange nuts (#2) on the U-bolt clamp (#3).

Note: the mast pole on the outside or inside of the upper and lower brackets. The mast pole (#6) can be installed to the outside (option 1) or inside (option2) of the upper & lower brackets (#4 and #5). The U-bolt clamps (#1) must be inserted and assembled correctly with the upper and lower brackets (#4 & #5) according to chosen option. Please refer the assembly drawing sheet.

STEP 2 - (Upper Bracket #4) Pre-assemble the upper bracket (#4), U-bolt clamp (#3) and the mast pole (#6). Using two of the U-Bolts (#1) and the flange nuts (#2). Finger tighten them to secure the upper bracket (#4) and before tightening the upper bracket (#4) measure to make sure that there is a minimum clearance of 300mm from the bottom bracket (#5) and that both are aligned to sit flat against the wall.

STEP 3 - Position the assembled mount on to the brick surface and ensure the upper bracket (#4) is not set within the top three courses of bricks of the wall, or within 300mm of any corner of the wall including window frame recesses.

Using a marking pen mark a drilling hole on the brick and not the mortar on one end of the upper bracket (#4) then drill the first hole. Note that the masonry anchor must go into the brick and not the mortar.

STEP 4 - Reposition the mount against the wall and insert then secure and tighten the first masonry anchor.

STEP 5 - Using a magnetic level adjust the mast pole (#6) so its vertically levelled then again using a marking pen mark then drill the second hole of the upper bracket (#4). Again, note that the masonry anchor must be set in the brick instead of the mortar. Insert and tighten the second masonry anchor.



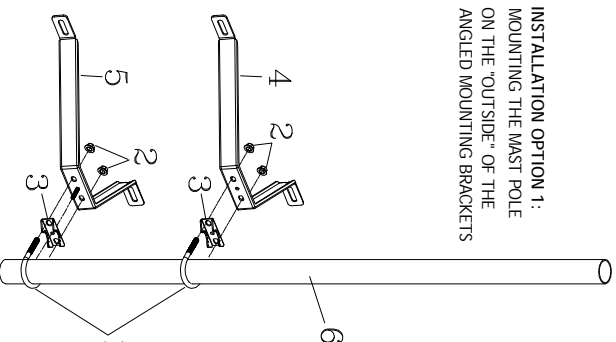

STEP 6 - Drill the remaining two holes on the lower bracket (#5) once again noting that the masonry anchors must be set into the brick instead of the mortar. Secure the lower mount bracket (#5) by inserting and tightening the two masonry anchors.

INSTALLATION OPTION 1:
MOUNTING THE MAST POLE
ON THE "OUTSIDE" OF THE
ANGLED MOUNTING BRACKETS

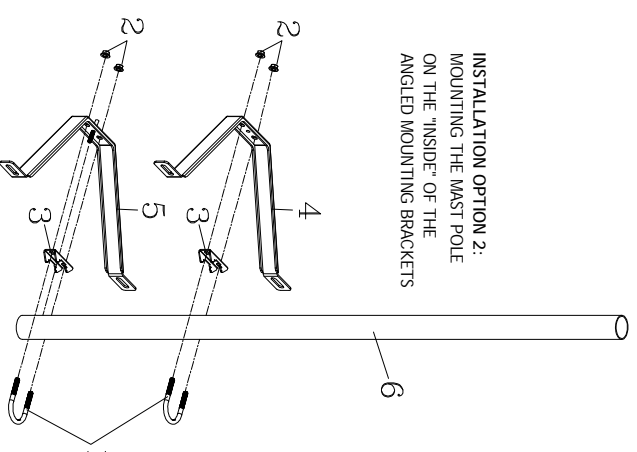

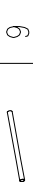
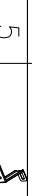
INSTALLATION OPTION 2:
MOUNTING THE MAST POLE
ON THE "INSIDE" OF THE
ANGLED MOUNTING BRACKETS

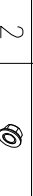

6		Mast Pole $\varnothing 45 \times L1300$	1
5		Lower Bracket with a Pin	1
4		Upper Bracket	1
3		U-Bolt Clamp	2
2		M8 Hex Flange Nut	4
1		M8*W46 U-Bolt	2
NO.	ITEM	DESCRIPTION	Q'TY