

Catalogue No: **GSV 1500 211**

FILTER FAN H152 x W152 x D75mm 24V DC 67m3/hr

Enclosures and Climate Control > Climate Control > Filter Fans and Exhaust Fans > Filter and Exhaust Fans > GSV Filter Fans > GSV - Fans, Grilles and Filters



- High heat resistant and self-extinguishing ABS plastic housing
- Easy clip-on mounting and screwless terminals
- Long life ball bearing fans
- Efficient filter mats
- Reversible fan motor on all sizes for maximum flexibility

Representative Photo Only
(actual product may vary based on configuration selections)

SPECIFICATIONS

Product Series	GSV Filter Fans
Component Type Heaters Filter Fans Regulating Devices	Fan, Grille and Filter
Un, Nominal Operational Voltage, DC	24 V DC
Fan Flow, Unimpeded	67 m ³ /hr unimpeded
Height	152 mm
Width	152 mm
Depth	75 mm
Height, Cutout	125 mm
Width, Cutout	125 mm
Mounting	Panel Mount
Material, Body / Housing	ABS material
Colour, Body / Housing	Light Grey (RAL 7035) colour
Reversible Fan	Yes Y/N
IP Rating	IP54

REFERENCES

IECEX Certificate	-
Supplier Declaration of Conformity:	-
Installation Guide:	-
User Manual:	-
Manufacturer Datasheet:	-
Manufacturer Catalogue & Product Selection:	-

Catalogue No: **GSV 1500 211**

FILTER FAN H152 x W152 x D75mm 24V DC 67m3/hr

Enclosures and Climate Control > Climate Control > Filter Fans and Exhaust Fans > Filter and Exhaust Fans > GSV Filter Fans > GSV - Fans, Grilles and Filters

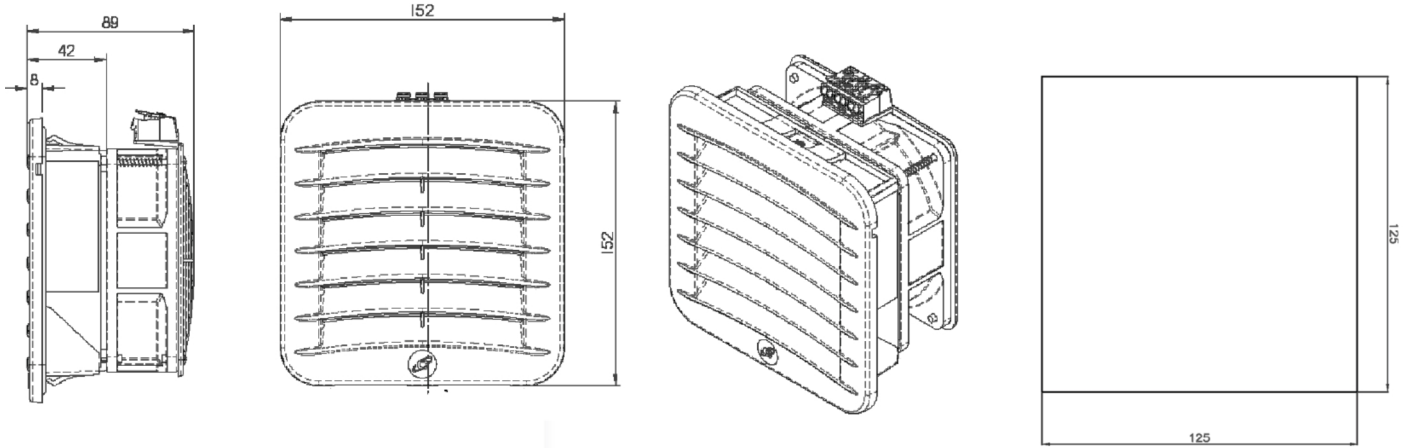

Dimension Diagram