

# ATV320U15M2C

variable speed drive, ATV320, 1.5kW,  
200...240V, 1 phase, compact





## Main

Range of product	Altivar Machine ATV320
Product or component type	Variable speed drive
Product specific application	Complex machines
Device short name	ATV320
Product destination	Synchronous motors Asynchronous motors
EMC filter	Class C2 EMC filter integrated
IP degree of protection	IP20 conforming to EN/IEC 61800-5-1
Type of cooling	Fan
Network number of phases	3 phases
[Us] rated supply voltage	380...500 V - 15...10 %
Supply frequency	50...60 Hz - 5...5 %
Motor power kW	2.2 kW for heavy duty
Motor power hp	3 hp for heavy duty
Line current	8.7 A at 380 V (heavy duty) 6.6 A at 500 V (heavy duty)
Prospective line Isc	5 kA
Apparent power	5.7 kVA at 500 V (heavy duty)
Continuous output current	5.5 A at 4 kHz for heavy duty
Maximum transient current	8.3 A during 60 s (heavy duty)
Asynchronous motor control profile	Flux vector control without sensor - Energy Saving Voltage/Frequency ratio - Energy Saving, quadratic U/f Flux vector control without sensor, standard Voltage/Frequency ratio, 2 points Voltage/frequency ratio, 5 points
Synchronous motor control profile	Vector control without sensor
Speed drive output frequency	0.1...599 Hz
Nominal switching frequency	4 kHz
Switching frequency	2...16 kHz adjustable 4...16 kHz with current derating
Safety function	STO (safe torque off) SIL 3 SLS (safe limited speed) SS1 (safe stop 1) SMS (safe maximum speed) GDL (guard door locking)
Communication port protocol	CANopen Modbus
Optional communication modules	Communication module, CANopen daisy chain RJ45 Communication module, CANopen SUB-D 9 Communication module, CANopen open style terminal block Communication module, EtherCAT RJ45 Communication module, DeviceNet Communication module, Ethernet/IP Communication module, Profibus DP V1 Communication module, Profinet Communication module, Ethernet Powerlink

## Complementary

Output voltage	$\leq$ power supply voltage
Permissible temporary current boost	1.5 x I <sub>n</sub> during 60 s (heavy duty)
Speed range	1...100 for asynchronous motor in open-loop mode
Speed accuracy	+/- 10 % of nominal slip 0.2 T <sub>n</sub> to T <sub>n</sub>
Torque accuracy	+/- 15 %
Transient overtorque	170...200 % of nominal motor torque
Braking torque	$\leq$ 170 % during 60 s with braking resistor
Regulation loop	Adjustable PID regulator
Motor slip compensation	Automatic whatever the load Not available in voltage/frequency ratio (2 or 5 points) Adjustable 0...300 %
Acceleration and deceleration ramps	Ramp switching Deceleration ramp automatic stop DC injection Linear Deceleration ramp adaptation CUS S U
Braking to standstill	By DC injection
Protection type	Input phase breaks: drive Overcurrent between output phases and earth: drive Overheating protection: drive Short-circuit between motor phases: drive Thermal protection: drive
Frequency resolution	Display unit: 0.1 Hz Analog input: 0.012/50 Hz
Electrical connection	Screw terminal, clamping capacity: 0.5...1.5 mm <sup>2</sup> , AWG 20...AWG 16 (control) Screw terminal, clamping capacity: 1.5...2.5 mm <sup>2</sup> , AWG 14...AWG 12 (motor/braking resistor) Screw terminal, clamping capacity: 1.5...4 mm <sup>2</sup> , AWG 14...AWG 10 (power supply)
Connector type	1 RJ45 (on front face) for Modbus/CANopen
Physical interface	2-wire RS 485 for Modbus
Transmission frame	RTU for Modbus
Transmission rate	4.8, 9.6, 19.2, 38.4 kbit/s for Modbus 50 kbps, 125 kbps, 250 kbps, 500 kbps, 1 Mbps for CANopen
Data format	8 bits, configurable odd, even or no parity for Modbus
Type of polarization	No impedance for Modbus
Number of addresses	1...127 for CANopen 1...247 for Modbus
Method of access	Slave CANopen
Supply	Internal supply for reference potentiometer (1 to 10 kOhm): 10.5 V DC +/- 5 %, <10 mA, protection type: overload and short-circuit protection
Analogue input number	3
Analogue input type	AI1 voltage: 0...10 V DC, impedance: 30000 Ohm, resolution 10 bits AI2 bipolar differential voltage: +/- 10 V DC, impedance: 30000 Ohm, resolution 10 bits AI3 current: 0...20 mA (or 4-20 mA, x-20 mA, 20-x mA or other patterns by configuration), impedance: 250 Ohm, resolution 10 bits
Discrete input number	7
Discrete input type	Programmable (sink/source) (DI1...DI4)24...30 V DC, with level 1 PLC Programmable as pulse input 20 kpps (DI5)24...30 V DC, with level 1 PLC Switch-configurable PTC probe (DI6)24...30 V DC Safe torque off (STO)24...30 V DC - 1500 Ohm
Discrete input logic	Negative logic (sink) (DI1...DI6), > 19 V (state 0), < 13 V (state 1) Positive logic (source) (DI1...DI6), < 5 V (state 0), > 11 V (state 1)
Analogue output number	1
Analogue output type	AQ1 software-configurable current: 0...20 mA, impedance: 800 Ohm, resolution 10 bits AQ1 software-configurable voltage: 0...10 V, impedance: 470 Ohm, resolution 10 bits
Sampling duration	2 Ms (AI1, AI2, AI3) - analog input 2 ms (AQ1) - analog output

Accuracy	+/- 0.2 % AI1, AI2, AI3 for a temperature of -10...60 °C analog input +/- 0.5 % AI1, AI2, AI3 for a temperature of 25 °C analog input +/- 1 % AQ1 for a temperature of 25 °C analog output +/- 2 % AQ1 for a temperature of -10...60 °C analog output
Linearity error	AI1, AI2, AI3: +/- 0.2...0.5 % of maximum value for analog input AQ1: +/- 0.3 % for analog output
Discrete output number	3
Discrete output type	Configurable relay logic: (R1A, R1B, R1C) NO/NC - 100000 cycles Configurable relay logic: (R2A, R2B) NO - 100000 cycles Logic: (LO)
Refresh time	Logic input (DI1...DI6): 8 ms (+/- 0.7 ms) Relay output (R1A, R1B, R1C): 2 ms Relay output (R2A, R2C): 2 ms
Minimum switching current	Relay output R1, R2: 5 mA at 24 V DC
Maximum switching current	Relay output R1 on resistive load, cos phi = 1: 3 A at 250 V AC Relay output R1 on resistive load, cos phi = 1: 4 A at 30 V DC Relay output R1, R2 on inductive load, cos phi = 0.4: 2 A at 250 V AC Relay output R1, R2 on inductive load, cos phi = 0.4: 2 A at 30 V DC Relay output R2 on resistive load, cos phi = 1: 5 A at 250 V AC Relay output R2 on resistive load, cos phi = 1: 5 A at 30 V DC
Specific application	Machinery
Motor power range	2.2...3 kW at 380...440 V 3 phases 2.2...3 kW at 480...500 V 3 phases
Motor starter type	Variable speed drive

## Environment

Isolation	Between power and control terminals
Insulation resistance	> 1 MOhm 500 V DC for 1 minute to earth
Operating position	Vertical +/- 10 degree
Electromagnetic compatibility	1.2/50 µs - 8/20 µs surge immunity test level 3 conforming to IEC 61000-4-5 Conducted radio-frequency immunity test level 3 conforming to IEC 61000-4-6 Electrical fast transient/burst immunity test level 4 conforming to IEC 61000-4-4 Electrostatic discharge immunity test level 3 conforming to IEC 61000-4-2 Radiated radio-frequency electromagnetic field immunity test level 3 conforming to IEC 61000-4-3 Voltage dips and interruptions immunity test conforming to IEC 61000-4-11
Pollution degree	2 conforming to EN/IEC 61800-5-1
Vibration resistance	1 gn (f= 13...200 Hz) conforming to EN/IEC 60068-2-6 1.5 mm peak to peak (f= 3...13 Hz) conforming to EN/IEC 60068-2-6
Shock resistance	15 gn for 11 ms conforming to EN/IEC 60068-2-27
Relative humidity	5...95 % without condensation conforming to IEC 60068-2-3 5...95 % without dripping water conforming to IEC 60068-2-3
Ambient air temperature for operation	-10...50 °C without 50...60 °C with derating factor
Ambient air temperature for storage	-25...70 °C
Operating altitude	<= 1000 m without 1000...2000 m with current derating 1 % per 100 m
Environmental characteristic	Chemical pollution resistance class 3C3 conforming to EN/IEC 60721-3-3 Dust pollution resistance class 3S2 conforming to EN/IEC 60721-3-3
Standards	EN/IEC 61800-3 EN/IEC 61800-5-1 EN 55011 class A group 1 Environment 1 category C2 EN 61800-3 Environment 2 category C2 EN 61800-3
Product certifications	RCM EAC CSA NOM 117 UL
Marking	CE

## Offer Sustainability

Sustainable offer status	Green Premium product
REACH Regulation	<a href="#">REACH Declaration</a>
EU RoHS Directive	Not applicable, out of EU RoHS legal scope <a href="#">EU RoHS Declaration</a>
Mercury free	Yes
RoHS exemption information	<a href="#">Yes</a>
China RoHS Regulation	<a href="#">Download RoHS China Declaration</a>
Environmental Disclosure	<a href="#">Product Environmental Profile</a>
Circularity Profile	<a href="#">End Of Life Information</a>
WEEE	The product must be disposed on European Union markets following specific waste collection and never end up in rubbish bins

## Dimensions

### Right View, Front View and Front View with EMC Plate

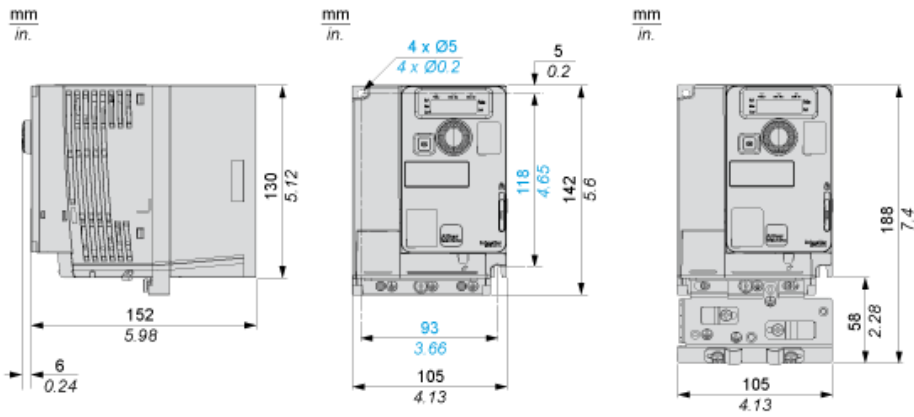

---

Mounting Types

---

Mounting Type A: Individual with Ventilation Cover

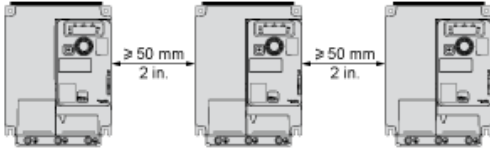

Only Possible at Ambient Temperature Less or Equal to 50 °C (122 °F)

Mounting Type B: Side by Side, Ventilation Cover Removed

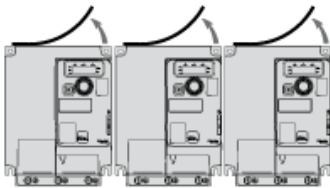

Mounting Type C: Individual, Ventilation Cover Removed

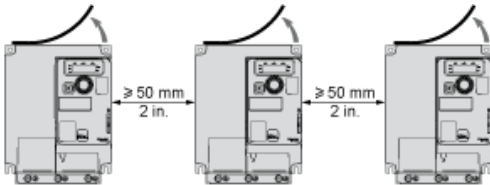

For Operation at Ambient Temperature Above 50 °C (122 °F)

Connection Diagrams

Diagram with Line Contactor

Connection diagrams conforming to standards ISO13849 category 1 and IEC/EN 61508 capacity SIL1, stopping category 0 in accordance with standard IEC/EN 60204-1.

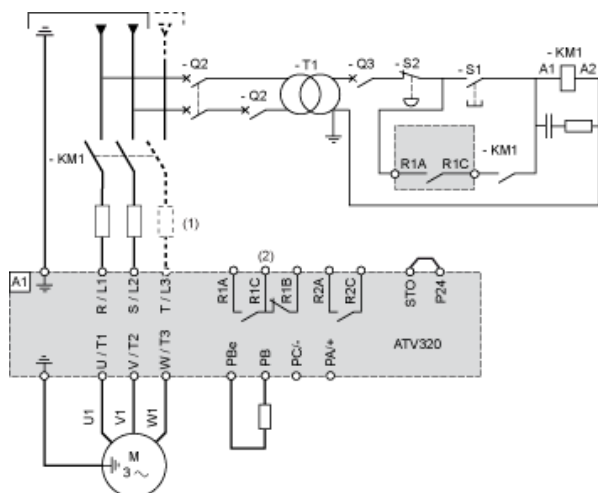

- (1) Line choke (if used)
- (2) Fault relay contacts, for remote signaling of drive status

Diagram with Switch Disconnect

Connection diagrams conforming to standards EN 954-1 category 1 and IEC/EN 61508 capacity SIL1, stopping category 0 in accordance with standard IEC/EN 60204-1.

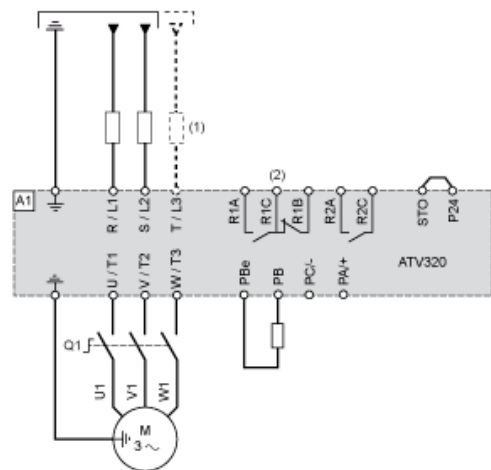

- (1) Line choke (if used)
- (2) Fault relay contacts, for remote signaling of drive status

Control Connection Diagram in Source Mode



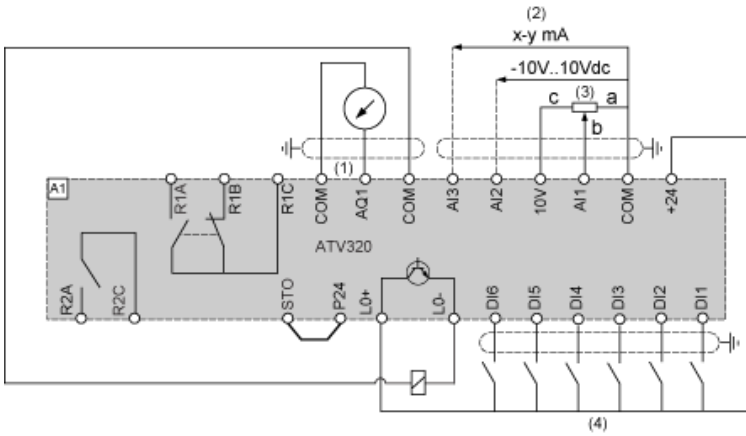

- (1) Analog output
- (2) Analog inputs
- (3) Reference potentiometer (10 kOhm maxi)
- (4) Digital inputs

### Digital Inputs Wiring

The logic input switch (SW1) is used to adapt the operation of the logic inputs to the technology of the programmable controller outputs. Switch SW1 set to “Source” position and use of the output power supply for the DIs.

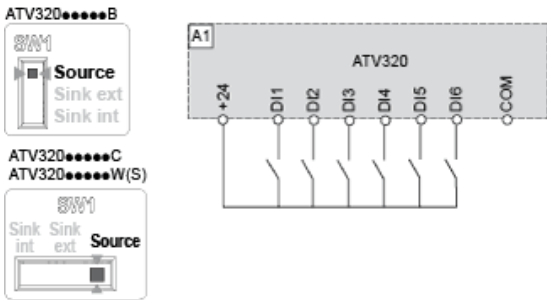

Switch SW1 set to “Source” position and use of an external power supply for the DIs.



Switch SW1 set to “Sink Int” position and use of the output power supply for the DIs.

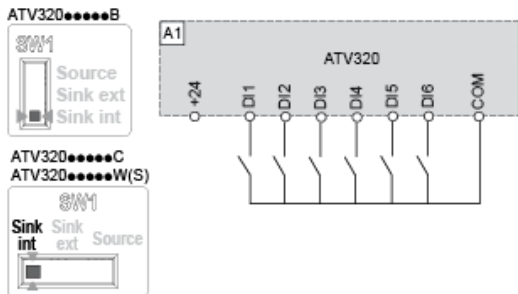

Switch SW1 set to "Sink Ext" position and use of an external power supply for the DIs.

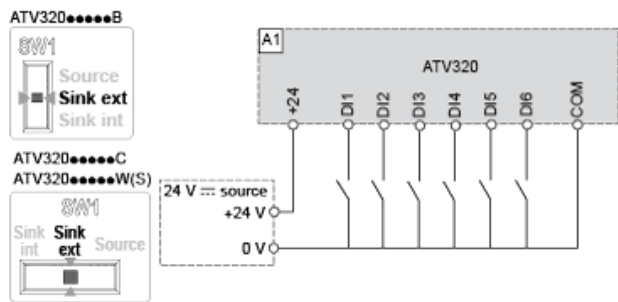

Derating Curves

Derating curve for the nominal drive current ( $I_n$ ) as a function of temperature and switching frequency (SF).

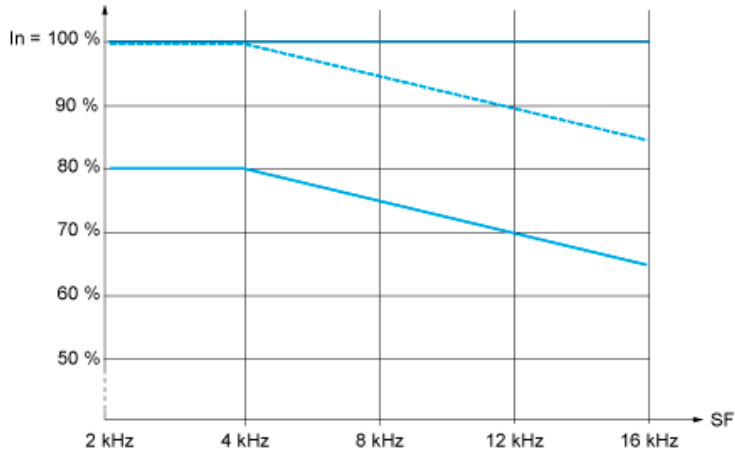

- 40 °C (104 °F) - Mounting type A, B and C
  - - - 50 °C (122 °F) - Mounting type A, B and C
  - 60 °C (140 °F) - Mounting type B and C
- In : Nominal Drive Current  
SF : Switching Frequency