

# SSP1D425BDT

solid state relay -panel mount-thermal pad-input 3.5-32VDC, output 1-150VDC,25 A



## Main

Range of product	Zelio Relay
Product or component type	Solid state relay
Provided equipment	Thermal pad
Device short name	SSP1
Mounting support	Panel
Network number of phases	1 phase
Contacts type and composition	1 NO
[In] rated current	25 A
Solid state output type	Mosfet output DC switching

## Complementary

[Uc] control circuit voltage	3.5...32 V DC
Minimum switching voltage	3.5 V DC turn-on
Maximum switching voltage	1 V DC turn-off
Response time	0.1 ms turn-on 0.1 ms turn-off
Input current limits	10...15 mA
Output voltage	1...150 V DC
Load current	0...25 A
Surge current	<= 106 A for 10 ms
Protection device type	Type 1 - 25 A miniature circuit breaker (MCB) - curve B Type 2 - 13 A miniature circuit breaker (MCB) - curve B
Leakage current	<= 0.3 mA off-state
Voltage drop	2.1 V on-state
Insulation resistance	1000 MOhm at 500 V DC
Capacitance unbalance	50 pF for input/output
Dielectric strength	2.5 kV AC for input/output 2.5 kV AC for input or output to case
[Uimp] rated impulse withstand voltage	2.5 kV output to case
Tightening torque	1.5...1.7 N.m for input 2...2.2 N.m for output
Connections - terminals	Forked type tag connectors : 9.2 x 4 mm for input Ring lugs : 9.2 x 4 mm for input Forked type tag connectors : 11.7 x 4.5 mm for output Ring lugs : 11.7 x 4.5 mm for output Screw terminals : 0.2...3.3 mm <sup>2</sup> , (AWG 24...AWG 12) with cable end for input Screw terminals : 0.5...5.26 mm <sup>2</sup> , (AWG 20...AWG 10) with cable end for output Screw terminals : 0.2...3.3 mm <sup>2</sup> , (AWG 24...AWG 12) without cable end for input Screw terminals : 0.5...8.26 mm <sup>2</sup> , (AWG 20...AWG 8) without cable end for output
Thermal resistance	0.22 °C/W junction to case
Thermal impedance	0.48 °C-in <sup>2</sup> /W at 25 psi
Local signalling	LED, green for input
IP degree of protection	IP20
Safety reliability data	MTTFd = 1875.9 years B10d = 1731395
Product weight	89.2 g

## Environment

The information provided in this documentation contains general descriptions and/or technical characteristics of the products contained herein. This documentation is not intended as a substitute for and is not to be used for determining suitability or reliability of these products for specific user applications. It is the duty of any such user or integrator to perform the appropriate and complete risk analysis, evaluation and testing of the products with respect to the relevant specific application or use thereof. Neither Schneider Electric Industries SAS nor any of its affiliates or subsidiaries shall be responsible or liable for misuse of the information contained herein.

ambient air temperature for operation	-40...80 °C
ambient air temperature for storage	-40...125 °C
pollution degree	2
overvoltage category	III
product certifications	CE CSA RoHS UL REACH EAC
marking	CE CSA UL EAC
standards	EN/IEC 60950-1 UL 508 EN/IEC 62314 CSA C22.2 No 14-13

## Offer Sustainability

Sustainable offer status	Green Premium product
RoHS (date code: YYWW)	Compliant - since 1522 - Schneider Electric declaration of conformity
REACH	Reference not containing SVHC above the threshold
Product environmental profile	Available
Product end of life instructions	Available

## Dimensions

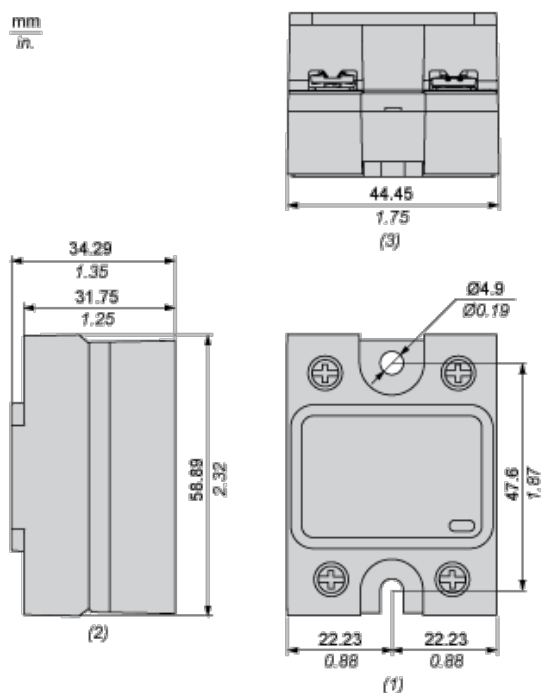

- (1) Front view
- (2) Side view
- (3) Bottom view

## Derating Curves

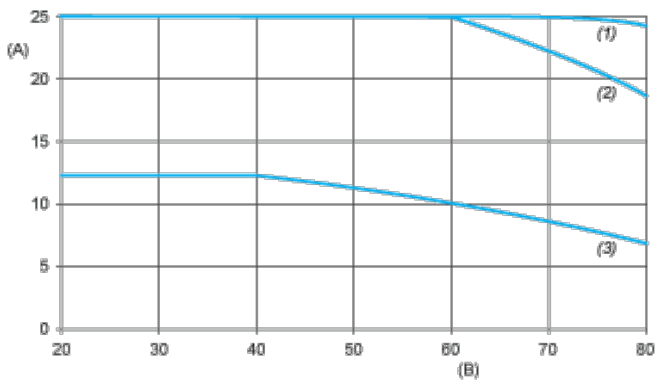

- A : Load Current (Arms)
- B : Ambient Temperature (°C)
- (1) For Heatsink SSRHD10
- (2) For Heatsink SSRHP17
- (3) No Heatsink