



Main

Range of product	Modicon M221
Product or component type	Graphic display
Range compatibility	Modicon M221
Current consumption	40 mA at 5 V DC via RJ45 connector
Power consumption in W	<= 1 W
Display type	Backlit colour STN LCD
Display colour	Monochrome
Display resolution	240 x 160 pixels
Number of key	6 (for navigation) 4 (configurable)

Complementary

Standards	EN/IEC 61131-2 EN/IEC 61010-2-201
Product certifications	CULus
Marking	CE
Mounting location	Front cabinet Ø 22 mm hole Bottom of cabinet Ø 22 mm hole, connection via mounting accessory
Connector type	RJ45 for communication and power supply
Height	126 mm
Width	80 mm
Depth	63 mm
Product weight	0.17 kg

Environment

ambient air temperature for operation	-15...50 °C
operating altitude	0...2000 m
storage altitude	0...2000 m
environmental characteristic	Corrosive gas free
relative humidity	95 % non-condensing for operation 95 % non-condensing for transport 95 % non-condensing for storage
ambient air temperature for storage	-40...70 °C
IP degree of protection	IP65 on front face IP20 on back part
pollution degree	2 conforming to EN/IEC 60664-1
vibration resistance	2 gn 1.5 mm (f = 3...150 Hz)
shock resistance	15 gn for 11 ms
electromagnetic compatibility	Radiated radio-frequency electromagnetic field immunity test test level: 1 V/m - 2...3 GHz conforming to EN/IEC 61000-4-3 Disturbing field emission test level: 120...69 dBµV/m QP - power lines (DC) conforming to EN/IEC 55011 Electrical fast transient/burst immunity test test level: 1 kV conforming to EN/IEC 61000-4-4 Electrostatic discharge test level: 8 kV - air discharge conforming to EN/IEC 61000-4-2 Surge immunity test test level: 0.5 kV - common mode conforming to EN/IEC 61000-4-5 Disturbing field emission test level: 30...230 MHz - class A - 10 m conforming to EN/IEC 55011 Radiated radio-frequency electromagnetic field immunity test test level: 10 V/m - 80

MHz...1 GHz conforming to EN/IEC 61000-4-3
 Conducted RF disturbances test level: 10 Vrms - 0.15...80 MHz conforming to EN/IEC 61000-4-6
 Disturbing field emission test level: 10...150 kHz - power lines (DC) conforming to EN/IEC 55011
 Disturbing field emission test level: 150...1500 kHz - power lines (DC) conforming to EN/IEC 55011
 Magnetic field at power frequency test level: 30 A/m - 50/60 Hz conforming to EN/IEC 61000-4-8
 Electrostatic discharge test level: 4 kV - contact discharge conforming to EN/IEC 61000-4-2
 Disturbing field emission test level: 1.5...30 kHz - power lines (DC) conforming to EN/IEC 55011
 Surge immunity test test level: 0.5 kV - differential mode conforming to EN/IEC 61000-4-5
 Radiated radio-frequency electromagnetic field immunity test test level: 3 V/m - 1.4...2 GHz conforming to EN/IEC 61000-4-3
 Disturbing field emission test level: 230 MHz...1 GHz - class A - 10 m conforming to EN/IEC 55011
 Disturbing field emission test level: 79...63 dB μ V/m QP - power lines (DC) conforming to EN/IEC 55011
 Disturbing field emission test level: 40 dB μ V/m QP - class A - 10 m conforming to EN/IEC 55011
 Disturbing field emission test level: 47 dB μ V/m QP - class A - 10 m conforming to EN/IEC 55011
 Disturbing field emission test level: 63 dB μ V/m QP - power lines (DC) conforming to EN/IEC 55011

Offer Sustainability

Sustainable offer status	Green Premium product
RoHS (date code: YYWW)	Compliant - since 1431 - Schneider Electric declaration of conformity
REACH	Reference not containing SVHC above the threshold
Product environmental profile	Available
Product end of life instructions	Available

Remote Graphic Display

Overview

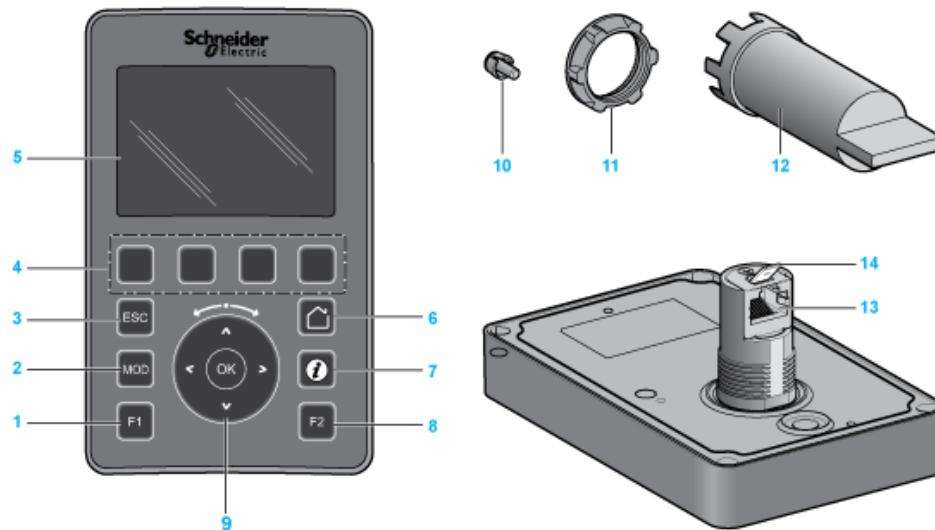

- 1 : F1 key
- 2 : MOD key
- 3 : ESC key
- 4 : R1 to R4 keys
- 5 : Graphic screen
- 6 : Home key
- 7 : Information key
- 8 : F2 key
- 9 : Touch wheel/OK/Arrows
- 10 : Anti-rotation tee

- 11 : Installation nut
- 12 : Socket wrench (ZB5AZ905)
- 13 : RJ45 serial line (RS-485)
- 14 : Connector for functional ground (earth)

Remote Graphic Display

Dimensions

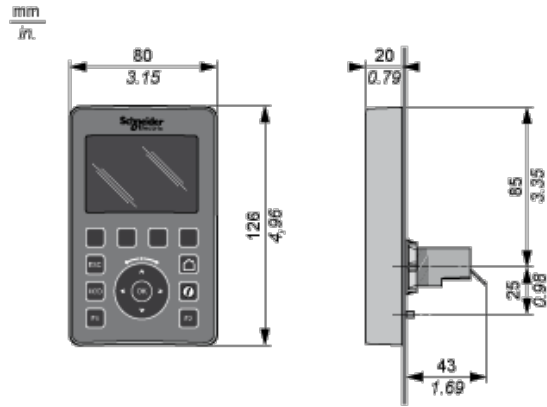

Mounting and Clearances

Mounting Hole Layout

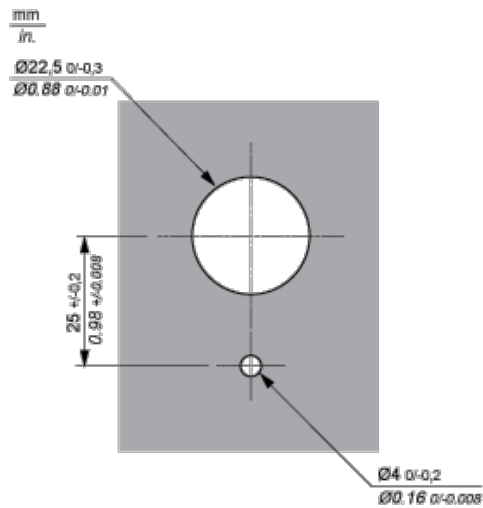

Minimum Clearances

