

PRODUCT SPECIFICATIONS

- Material:** Aluminium
- Colour:** Grey
- Input Voltage:** 240v AC
- Output Voltage:** 12v DC or 24v DC
- Output Power:** 30w*
- No. Output Cables:** 1
- Wiring:** Parallel
- IP Rating:** IP66
- Dimmable:** No
- Warranty:** 2 Years Replacement**



Supplied with Flex & Plug

COMPATIBLE WITH



All Low Voltage Light Fittings and LED Strip



IP RATING



APPROVAL



DIMENSIONS

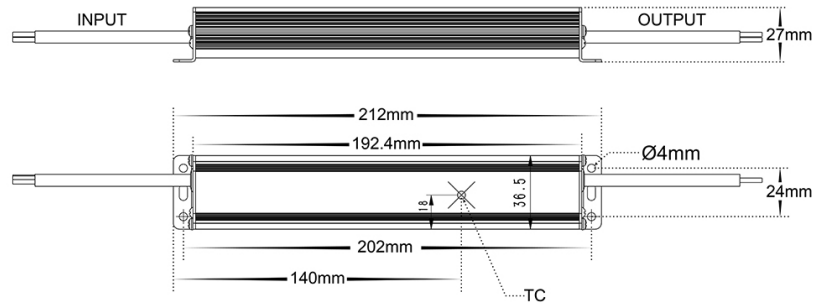

Product Ordering

IMAGE	OUTPUT VOLTAGE	PART NUMBER
	12v DC	HV9658-12V30W
	24v DC	HV9658-24V30W

SAMPLE INSTALLATION DIAGRAM

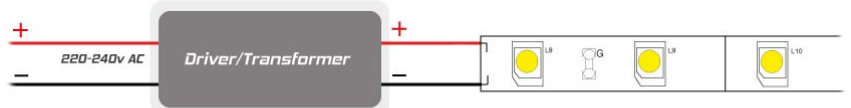

* Recommended maximum Load of 24w

** See Warranty Terms and Conditions for more information

For more information contact Havit Lighting

ADDRESS:
143 Beauchamp Road
Matraville NSW 2036
Australia

Tel: 02 9381 8300
Fax: 02 9666 8881
Email: sales@havit.com.au
web: www.havit.com.au

Output	DC Voltage	12V	24V
	Rated Current	2.5A	1.25A
	Current Range	0-2.5A	0-1.25A
	Rated Power	30W	30W
	Ripple and Noise(max)	120mVp-p	240mVp-p
	Voltage Tolerance	±4%	±2%
	Line Regulation	±1%	±1%
	Load Regulation	±2%	±2%
	No. Output Cables	1	1
	Set up time	2000ms, 50ms(at full load) 110Vac/230Vac	
	Holding time(Typ.)	15ms(at full load) 110Vac/230Vac	
Input	Voltage range Note 2	90~264Vac	
	Frequency range	47~63Hz	
	Power factor(Typ.)	PF≥0.9/230V(at full load)	
	Efficiency(Typ.)	83.5%	84.5%
	AC current	0.20A/230Vac	
	Inrush current(Typ.)	Cold start: 50A/230Vac	
	Leakage current	<0.75mA/240Vac	
Protection	Over load	104%-130% of the rated output power	
		Protection mode: constant current limiting, recovers automatically after the load reduced.	
	Short circuit	Protection type: Hiccup mode, recovers automatically after fault conditions removed	
	Over voltage	13-18V	24.5-35V
		Protection type: Hiccup mode, recovers automatically after fault conditions removed	
Over temperature	Ta: 60°C~70°C		
	Protection type: Hiccup mode, recovers automatically after fault conditions removed		
Environment	Working temperature	Ta: -25°C~ +50°C	
	Working humidity	10%~90%RH, non-condensing	
	Storage temp. and humidity	-25°C ~+75°C, 5%~95%RH	
	Temp. coefficient	±0.05%/°C (0~40°C)	
	Vibration	10-300Hz, 1G 10min./cycle, period for 60min. each along X, Y, Z axes	
Safety and EMC	Safety standards	Compliance to EN61347-1, EN61347-2-13, AS/NZS61347-1, Ip66 waterproof rating.	
	Withstand voltage	I/P-O/P: 3.75KVAC I/P-FG: 1.875KVAC O/P-FG: 0.5KVAC	
	Insulation resistance	I/P-O/P, I/P-FG, O/P-FG: 100Mohms/500Vdc 25°C /70%RH	
	EMC Emission	Compliance to AS/NZS CISPR15	
	EMC Immunity	Compliance to AS/NZS CISPR15	