



## Main

Range of product	Harmony XVU
Product or component type	Modular tower light
Accessory / separate part type	Fixing plate
Accessory / separate part category	Mounting and fixing accessory
Component name	XVU
Mounting diameter	60 mm

## Complementary

Pole height	400 mm
Mounting support	Metal bracket with pole
Product compatibility	Top : AC/DC body
Material	ABS (acrylonitrile butadiene-styrene) Aluminium PC (polycarbonate) PBT (polybutylene terephthalate) V-0 flame retardant conforming to UL 94
Housing colour	Black
Connections - terminals	Push-in
[Us] rated supply voltage	110...240 V AC 24 V AC/DC
Length	450 mm
Product weight	0.32 kg

## Environment

ambient air temperature for storage	-40...70 °C
ambient air temperature for operation	-25...50 °C
IP degree of protection	IP32
product certifications	CE CSA UL

## Offer Sustainability

Sustainable offer status	Green Premium product
RoHS (date code: YYWW)	Compliant - since 1529 - Schneider Electric declaration of conformity
REACH	Reference not containing SVHC above the threshold
Product environmental profile	Available
Product end of life instructions	Available

## Fixing Unit - Metal Bracket with Pole

### Dimensions with Fixing Unit

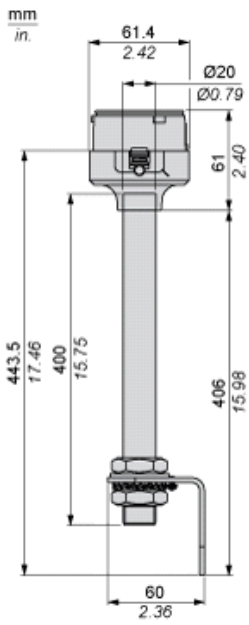

Dimensions for Metal Bracket

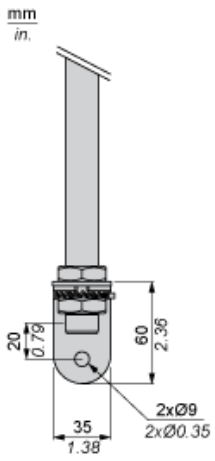

Modular Tower Lights Mounting

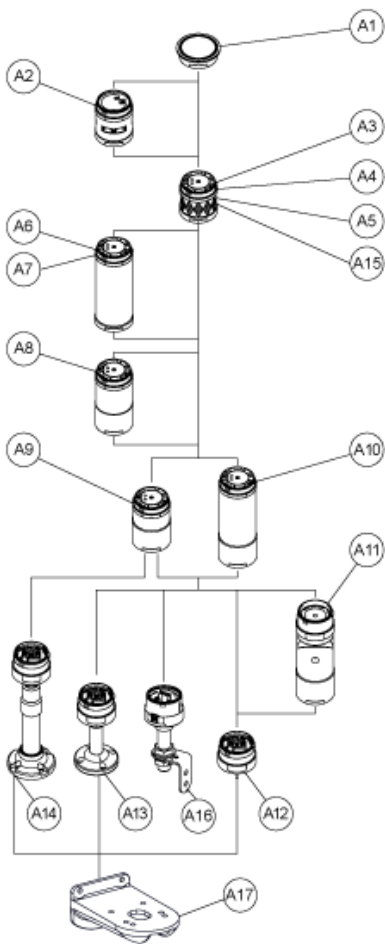

Drawing	Part number	Part name
A1	-	Top cover
	-	Top cover (Silver)
A2	XVUC9S	Buzzer unit
	XVUC9SQ	Buzzer unit (Silver)
A3	XVUC23	Green LED unit
	XVUC24	Red LED unit
	XVUC25	Orange LED unit
	XVUC26	Blue LED unit
	XVUC27	White LED unit
	XVUC28	Yellow LED unit
A4	XVUC29	Multi-LED unit
A5	XVUC29P	Multi-LED unit, Pulse signal
A6	XVUC9V	Sound unit
A7	XVUC9VP	Sound unit, Pulse signal
A8	XVUC020	Extender
	XVUC020Q	Extender (Silver)
A9	XVUC21B	DC body
	XVUC21BQ	DC body (Silver)
A10	XVUC21M	AC body NPN
	XVUC21MP	AC body PNP

	XVUC21MQP	AC body PNP (Silver)
<b>A11</b>	XVUZ06	Flexible option
<b>A12</b>	XVUZ01	Fixing Unit - Direct mounting (3 pins)
	XVUZ01Q	Fixing Unit - Direct mounting (Silver,3 pins)
	XVUZ03	Fixing Unit - Direct mounting (2 pins)
	XVUZ04	Fixing Unit - Direct mounting (4 pins)
<b>A13</b>	XVUZ02	Fixing Unit - Plate with Pole (100 mm)
	XVUZ02Q	Fixing Unit - Plate with Pole (100 mm, Silver)
	XVUZ400	Fixing Unit - Plate with Pole (400 mm)
	XVUZ800	Fixing Unit - Plate with Pole (800 mm)
<b>A14</b>	XVUZ05	Fixing Unit - Plate with adjustment pole (100-385 mm)
<b>A15</b>	XVUC43	Green LED unit, Flash
	XVUC44	Red LED unit, Flash
	XVUC45	Orange LED unit, Flash
	XVUC46	Blue LED unit, Flash
	XVUC47	White LED unit, Flash
	XVUC48	Yellow LED unit, Flash
<b>A16</b>	XVUZ100T	Fixing Unit - Metal bracket with pole (100 mm)
	XVUZ250T	Fixing Unit - Metal bracket with pole(250 mm)
	XVUZ400T	Fixing Unit - Metal bracket with pole (400 mm)
<b>A17</b>	XVUZ12	Fixing plate for use on vertical support - black

## Illuminated Units, Multi-LED and Audible Units Wiring

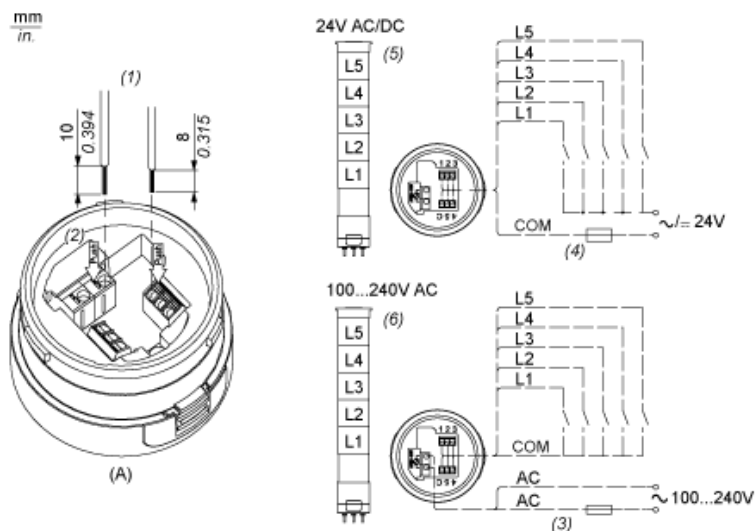

- (A) Fixing Unit
- (1) Dimensions of Wiring size
- (2) Push-in Wire Connectors
- (3) Fuse : 2A ,250V
- (4) Fuse : 0.5A ,125V
- (5) Modular Tower Lights 24V AC/DC
- (6) Modular Tower Lights 100...240V AC
- L1 Illuminated LED Units  
to  
L5 :