

Main

Product or component type	Braking resistor
---------------------------	------------------

Complementary

Range compatibility	Altivar Easy 310 Altivar Process ATV900 Altivar Machine ATV320 Altivar Machine ATV340 Altivar 310L
Product compatibility	Variable speed drive ATV930 wall mount 5.5 kW 380...480 V light cycle Variable speed drive ATV930 wall mount 7.5 kW 380...480 V light cycle Variable speed drive ATV930 wall mount 1.5 kW 200...240 V light cycle Variable speed drive ATV930 wall mount 2.2 kW 200...240 V light cycle Variable speed drive ATV950 wall mount 5.5 kW 380...480 V light cycle Variable speed drive ATV950 wall mount 7.5 kW 380...480 V light cycle Variable speed drive ATV930 wall mount 1.5 kW 200...240 V medium cycle Variable speed drive ATV930 wall mount 2.2 kW 200...240 V medium cycle Variable speed drive ATV340 4 kW 380...480 V light cycle Variable speed drive ATV340 5.5 kW 380...480 V light cycle Variable speed drive ATV320 0.55 kW 200...240 V Variable speed drive ATV320 0.75 kW 200...240 V Variable speed drive ATV320 1.1 kW 200...240 V Variable speed drive ATV320 1.5 kW 200...240 V Variable speed drive ATV320 4 kW 380...480 V Variable speed drive ATV320 5.5 kW 380...480 V Variable speed drive ATV320 5.5 kW 525...600 V Variable speed drive ATV310 5.5 kW Variable speed drive ATV310 7.5 kW Variable speed drive ATV930 7.5 kW 500...690 V light cycle Variable speed drive ATV930 11 kW 500...690 V light cycle Variable speed drive ATV930 10 hp 600 V light cycle Variable speed drive ATV930 15 hp 600 V light cycle Variable speed drive ATV310L 0.75 kW Variable speed drive ATV310L 1.5 kW Variable speed drive ATV310L 2.2 kW Variable speed drive ATV310L 3 kW Variable speed drive ATV310L 4 kW Variable speed drive ATV310L 5.5 kW
Duty cycle	Light cycle (heavy duty) : ≤ 0.8 s braking with 150 % braking torque for a 40 s cycle Light cycle (normal duty) : ≤ 0.8 s braking with 120 % braking torque for a 40 s cycle Medium cycle (normal duty) : ≤ 4 s braking with 135 % braking torque for a 40 s cycle Medium cycle (heavy duty) : ≤ 4 s braking with 165 % braking torque for a 40 s cycle
Average power available	0.16 kW at 50 °C
Ohmic value	60 Ohm
Electrical connection	Terminal, clamping capacity: ≤ 10 mm ² , AWG 8 for drive
Protection type	Thermal protection via drive
Width	105 mm
Height	345 mm
Depth	100 mm
Product weight	2 kg

The information provided in this documentation contains general descriptions and/or technical characteristics of the products contained herein. This documentation is not intended as a substitute for and is not to be used for determining suitability or reliability of these products for specific user applications. It is the duty of any such user or integrator to perform the appropriate and complete risk analysis, evaluation and testing of the products with respect to the relevant specific application or use thereof. Neither Schneider Electric Industries SAS nor any of its affiliates or subsidiaries shall be responsible or liable for misuse of the information contained herein.

Environment

ambient air temperature for operation	0...50 °C
ambient air temperature for storage	-25...70 °C
IP degree of protection	IP20

Offer Sustainability

Sustainable offer status	Not Green Premium product
RoHS (date code: YYWW)	Compliant - since 1533 - Schneider Electric declaration of conformity

Dimensions

Right Side and Front View

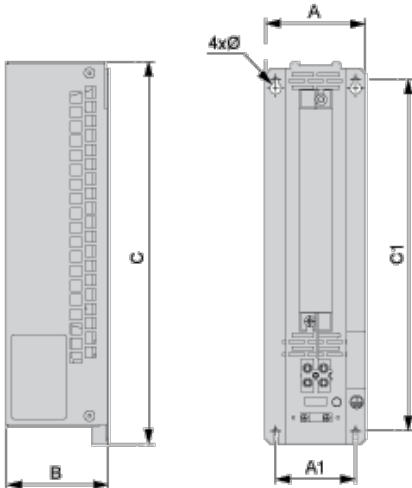

Dimensions in mm

A	B	C	A1	C1	Ø
105	100	345	72	316	4.5

Dimensions in in.

A	B	C	A1	C1	Ø
4.13	3.94	13.58	2.83	12.44	0.18

Mounting and Clearance

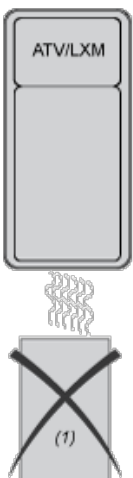

(1) Braking resistor

mm
in.

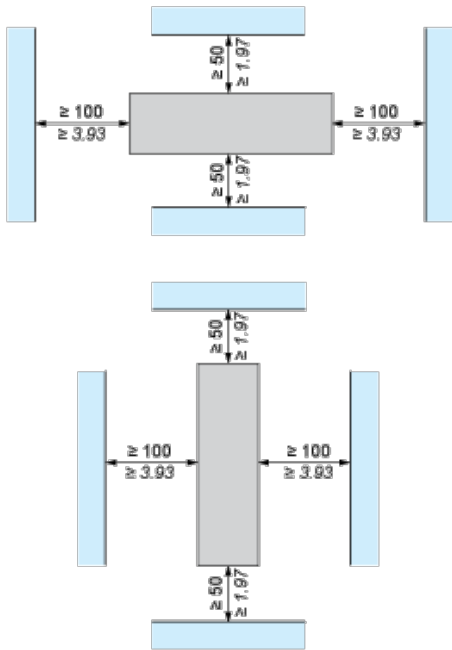

Recommended Schema

1 Braking Resistor

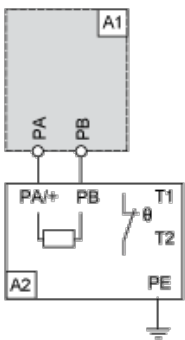

A1 : Drive or external braking unit

A2 : Braking resistor

PA, Bus DC

PB :

T1, Temperature control switch

T2 :

2 Braking Resistors

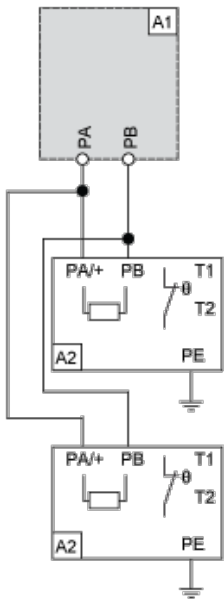

A1 : Drive or external braking unit

A2 : Braking resistor

PA, Bus DC

PB :

T1, Temperature control switch

T2 :