



Main

Range of product	Modicon M241
Product or component type	Logic controller
[Us] rated supply voltage	24 V DC
Discrete input number	14 discrete input including 8 fast input conforming to IEC 61131-2 Type 1
Discrete output type	Transistor
Discrete output number	10 transistor including 4 fast output
Discrete output voltage	24 V DC for transistor output
Discrete output current	0.5 A with Q0...Q9 terminal(s) for transistor output 0.1 A with Q0...Q3 terminal(s) for fast output (PTO mode)

Complementary

Discrete I/O number	24
Number of I/O expansion module	7 (local I/O architecture) 14 (remote I/O architecture)
Supply voltage limits	20.4...28.8 V
Inrush current	<= 50 A
Power consumption in W	32.6...40.4 W with max number of I/O expansion module
Discrete input logic	Sink or source
Discrete input voltage	24 V
Discrete input voltage type	DC
Voltage state 1 guaranteed	>= 15 V for input
Voltage state 0 guaranteed	<= 5 V for input
Discrete input current	5 mA for input 10.7 mA for fast input
Input impedance	4.7 kOhm for input 2.81 kOhm for fast input
Response time	50 µs turn-on operation with I0...I13 terminal(s) for input 50 µs turn-off operation with I0...I13 terminal(s) for input <= 2 µs turn-on operation with I0...I7 terminal(s) for fast input <= 2 µs turn-off operation with I0...I7 terminal(s) for fast input <= 34 µs turn-on operation with Q0...Q9 terminal(s) for output <= 250 µs turn-off operation with Q0...Q9 terminal(s) for output <= 2 µs turn-on operation with Q0...Q3 terminal(s) for fast output <= 2 µs turn-off operation with Q0...Q3 terminal(s) for fast output
Configurable filtering time	1 µs for fast input 12 ms for fast input 0 ms for input 1 ms for input 4 ms for input 12 ms for input
Discrete output logic	Positive logic (source)
Output voltage limits	30 V DC
Current per output common	2 A with Q0...Q3 terminal for fast output 2 A with Q4...Q7 terminal for output 1 A with Q8...Q9 terminal for output
Output frequency	<= 20 kHz for fast output (PWM mode) <= 100 kHz for fast output (PLS mode) <= 1 kHz for output
Accuracy	+/- 0.1 % at 0.02...0.1 kHz for fast output +/- 1 % at 0.1...1 kHz for fast output

The information provided in this documentation contains general descriptions and/or technical characteristics of the performance of the products contained herein. This documentation is not intended as a substitute for and is not to be used for determining suitability or reliability of these products for specific user applications. It is the duty of any such user or integrator to perform the appropriate and complete risk analysis, evaluation and testing of the products with respect to the relevant specific application or use thereof. Neither Schneider Electric Industries SAS nor any of its affiliates or subsidiaries shall be responsible or liable for misuse of the information contained herein.

Leakage current	<= 5 µA for output
Voltage drop	<= 1 V
Tungsten load	<= 2.4 W
Protection type	Short-circuit protection Short-circuit and overload protection with automatic reset Reverse polarity protection for fast output
Reset time	10 ms automatic reset output 12 s automatic reset fast output
Memory capacity	8 MB for program 64 MB for system memory RAM
Data backed up	128 MB built-in flash memory for backup of user programs
Data storage equipment	<= 32 GB SD card optional
Battery type	BR2032 lithium non-rechargeable, battery life: 4 yr
Backup time	2 years at 25 °C
Execution time for 1 KInstruction	0.3 ms for event and periodic task 0.7 ms for other instruction
Application structure	8 event tasks 4 cyclic master tasks 3 cyclic master tasks + 1 freewheeling task 8 external event tasks
Realtime clock	With
Clock drift	<= 60 s/month at 25 °C
Positioning functions	PTO function 4 channel(s) (positioning frequency: 100 kHz) PTO function 4 channel(s) for transistor output (positioning frequency: 1 kHz)
Counting input number	4 fast input (HSC mode) at 200 kHz 14 standard input at 1 kHz
Control signal type	A/B signal at 100 kHz for fast input (HSC mode) Pulse/direction signal at 200 kHz for fast input (HSC mode) Single phase signal at 200 kHz for fast input (HSC mode)
Integrated connection type	USB port with connector mini B USB 2.0 Ethernet with connector RJ45 Non isolated serial link "serial 1" with connector RJ45 and interface RS232/RS485 Non isolated serial link "serial 2" with connector removable screw terminal block and interface RS485 CANopen J1939 with connector male SUB-D 9
Supply	Serial link supply "serial 1" at 5 V, 200 mA
Transmission rate	1.2...115.2 kbit/s (115.2 kbit/s by default) for bus length of 15 m - communication protocol: RS485 1.2...115.2 kbit/s (115.2 kbit/s by default) for bus length of 3 m - communication protocol: RS232 480 Mbit/s for bus length of 3 m - communication protocol: USB 10/100 Mbit/s - communication protocol: Ethernet 1000 kbit/s for bus length of 20 m - communication protocol: CANopen 800 kbit/s for bus length of 40 m - communication protocol: CANopen 500 kbit/s for bus length of 100 m - communication protocol: CANopen 250 kbit/s for bus length of 250 m - communication protocol: CANopen 125 kbit/s for bus length of 500 m - communication protocol: CANopen 50 kbit/s for bus length of 1000 m - communication protocol: CANopen 20 kbit/s for bus length of 2500 m - communication protocol: CANopen
Communication port protocol	Modbus non isolated serial link with master/slave method
Port Ethernet	1 - 10BASE-T/100BASE-TX port with copper cable support
Communication service	Ethernet/IP adapter DHCP client IEC VAR ACCESS Modbus TCP client Modbus TCP server Modbus TCP slave device SNMP client/server FTP client/server SQL client Send and receive email from the controller based on TCP/UDP library Web server (WebVisu & XWeb system) OPC UA server DNS client
Local signalling	1 LED red for module error (ERR) 1 LED green for PWR 1 LED green for RUN 1 LED green for SD card access (SD) 1 LED red for BAT

	1 LED green for SL1 1 LED green for SL2 1 LED per channel green for I/O state 1 LED red for I/O error (I/O) 1 LED red for bus fault on TM4 (TM4) 1 LED green for Ethernet port activity 1 LED green for CANopen run 1 LED green for CANopen error
Electrical connection	Removable screw terminal block for inputs and outputs (pitch 5.08 mm) Removable screw terminal block for connecting the 24 V DC power supply (pitch 5.08 mm)
Cable distance between devices	Shielded cable: 10 m for fast input Shielded cable: 3 m for fast output Unshielded cable: 50 m for input Unshielded cable: 50 m for output
Insulation	500 V AC between fast input and internal logic Non-insulated between inputs 500 V AC between output and internal logic 500 V AC between fast output and internal logic Non-insulated between outputs 500 V AC between input and internal logic 500 V AC between supply and internal logic Non-insulated between supply and ground
Marking	CE
Surge withstand	1 kV for power lines (DC) in common mode conforming to EN/IEC 61000-4-5 1 kV for shielded cable in common mode conforming to EN/IEC 61000-4-5 0.5 kV for power lines (DC) in differential mode conforming to EN/IEC 61000-4-5 1 kV for relay output in differential mode conforming to EN/IEC 61000-4-5 1 kV for input in common mode conforming to EN/IEC 61000-4-5 1 kV for transistor output in common mode conforming to EN/IEC 61000-4-5
Web services	Web server
Maximum number of connections	16 connection(s) for Ethernet/IP device 8 connection(s) for Modbus server
CANopen feature profile	DR 303-1 DS 301 V4.02
Number of slave	<= 63 CANopen
Mounting support	Top hat type TH35-15 rail conforming to IEC 60715 Top hat type TH35-7.5 rail conforming to IEC 60715 Plate or panel with fixing kit
Height	90 mm
Depth	95 mm
Width	150 mm
Product weight	0.53 kg

Environment

standards	UL 508 CSA C22.2 No 142 ANSI/ISA 12-12-01 UL 1604 CSA C22.2 No 213 EN/IEC 61131-2 : 2007 Marine specification (LR, ABS, DNV, GL)
product certifications	CSA CULus IACS E10 RCM
resistance to electrostatic discharge	4 kV on contact conforming to EN/IEC 61000-4-2 8 kV in air conforming to EN/IEC 61000-4-2
resistance to electromagnetic fields	10 V/m (80 MHz...1 GHz) conforming to EN/IEC 61000-4-3 3 V/m (1.4 GHz...2 GHz) conforming to EN/IEC 61000-4-3 1 V/m (2 GHz...3 GHz) conforming to EN/IEC 61000-4-3
resistance to fast transients	2 kV for power lines conforming to EN/IEC 61000-4-4 1 kV for Ethernet line conforming to EN/IEC 61000-4-4 1 kV for serial link conforming to EN/IEC 61000-4-4 1 kV for input conforming to EN/IEC 61000-4-4 1 kV for transistor output conforming to EN/IEC 61000-4-4
resistance to conducted disturbances	10 V (0.15...80 MHz) conforming to EN/IEC 61000-4-6 3 V (0.1...80 MHz) conforming to Marine specification (LR, ABS, DNV, GL) 10 V (spot frequency (2, 3, 4, 6.2, 8.2, 12.6, 16.5, 18.8, 22, 25 MHz)) conforming to

electromagnetic emission	Conducted emissions, test level: 120...69 dB μ V/m QP, condition of test: power lines (radio frequency: 10...150 kHz) conforming to EN/IEC 55011 Conducted emissions, test level: 63 dB μ V/m QP, condition of test: power lines (radio frequency: 1.5...30 MHz) conforming to EN/IEC 55011 Radiated emissions, test level: 40 dB μ V/m QP with class A (radio frequency: 30...230 MHz) conforming to EN/IEC 55011 Conducted emissions, test level: 79...63 dB μ V/m QP, condition of test: power lines (radio frequency: 150...1500 kHz) conforming to EN/IEC 55011 Radiated emissions, test level: 47 dB μ V/m QP with class A (radio frequency: 230...1000 MHz) conforming to EN/IEC 55011
immunity to microbreaks	10 ms
ambient air temperature for operation	-10...55 °C for horizontal installation -10...50 °C for vertical installation
ambient air temperature for storage	-25...70 °C
relative humidity	10...95 % without condensation in operation 10...95 % without condensation in storage
IP degree of protection	IP20 with protective cover in place
pollution degree	2
operating altitude	0...2000 m
storage altitude	0...3000 m
vibration resistance	3.5 mm (vibration frequency: 5...8.4 Hz) on symmetrical rail 3 gn (vibration frequency: 8.4...150 Hz) on symmetrical rail 3.5 mm (vibration frequency: 5...8.4 Hz) on panel mounting 3 gn (vibration frequency: 8.4...150 Hz) on panel mounting
shock resistance	15 gn for 11 ms

Offer Sustainability

Sustainable offer status	Green Premium product
RoHS (date code: YYWW)	Compliant - since 1330 - Schneider Electric declaration of conformity
REACH	Reference contains SVHC above the threshold
Product environmental profile	Available
Product end of life instructions	Available

Dimensions

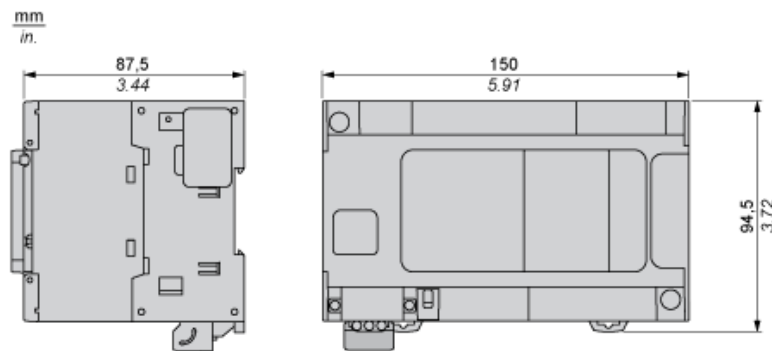

Clearance

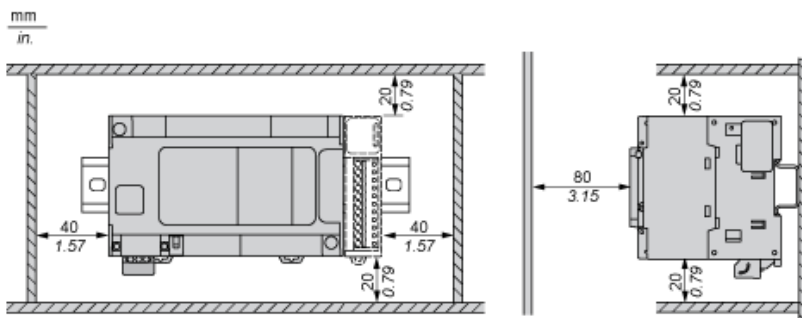

Mounting Position

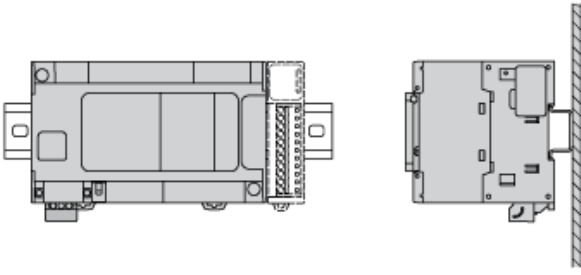

Acceptable Mounting

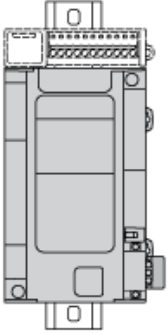

NOTE: Expansion modules must be mounted above the logic controller.

Incorrect Mounting

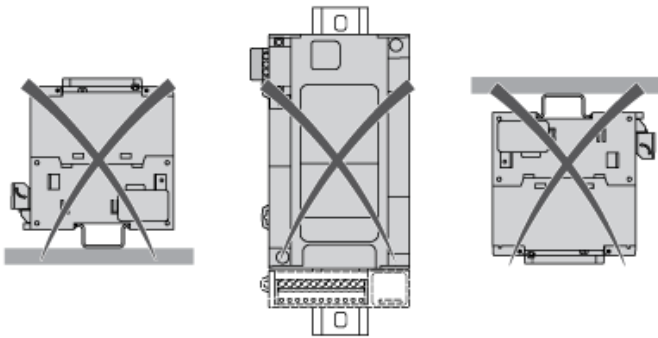

Direct Mounting On a Panel Surface

Mounting Hole Layout

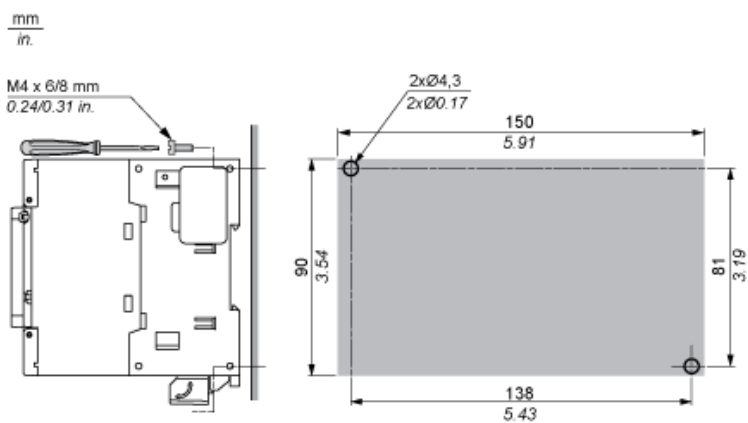

Digital Inputs

Wiring Diagram

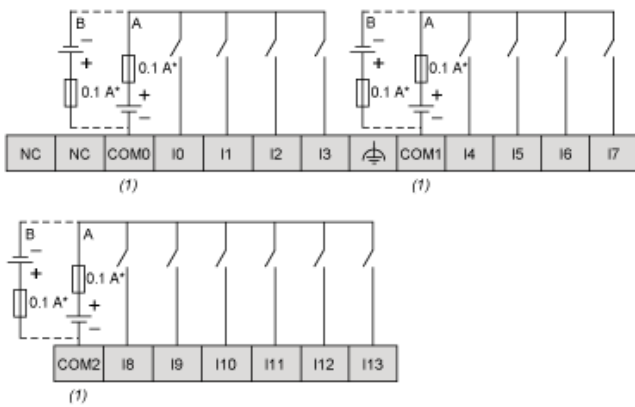

(*) : Type T fuse

(1) : The COM0, COM1 and COM2 terminals are not connected internally

(A) : Sink wiring (positive logic)

(B) : Source wiring (negative logic)

Fast Input Wiring (I0...I7)

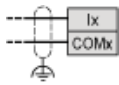

Fast Transistor Outputs

Wiring Diagram

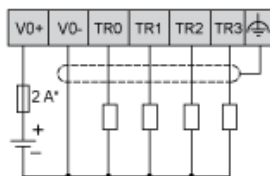

(*) : 2 A fast-blow fuse

Transistor Outputs

Wiring Diagram

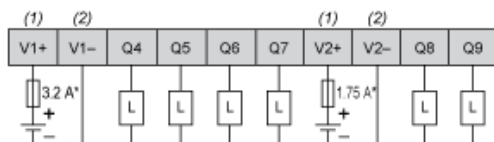

(*) : Type T fuse

(1) : The V1+ and V2+ terminals are not connected internally.

(2) : The V1- and V2- terminals are not connected internally.

USB Mini-B Connection

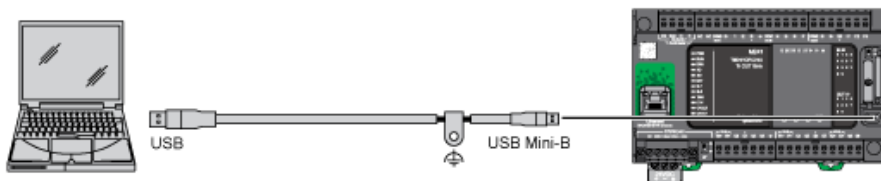

Ethernet Connection to a PC

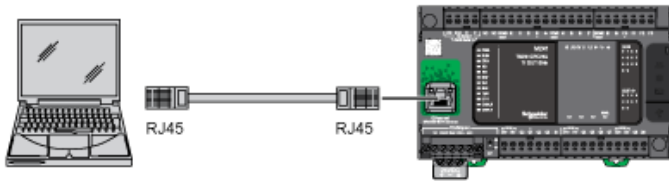

CANopen Connection

Wiring Diagram

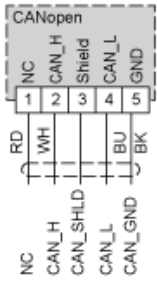

Pin	Signal	Description	Marking	Color of Cable
1	Not used	Reserved	NC	red
2	CAN_H	CAN_H bus line (dominant high)	CAN_H	white
3	CAN_SHLD	Optional CAN shield	Shield	-
4	CAN_L	CAN_L bus line (dominant low)	CAN_L	blue
5	CAN_GND	CAN Ground	GND	black