

Modicon X80

BMXNRP0200/0201 Fiber Converter Modules

User Guide

Original instructions

10/2019

The information provided in this documentation contains general descriptions and/or technical characteristics of the performance of the products contained herein. This documentation is not intended as a substitute for and is not to be used for determining suitability or reliability of these products for specific user applications. It is the duty of any such user or integrator to perform the appropriate and complete risk analysis, evaluation and testing of the products with respect to the relevant specific application or use thereof. Neither Schneider Electric nor any of its affiliates or subsidiaries shall be responsible or liable for misuse of the information contained herein. If you have any suggestions for improvements or amendments or have found errors in this publication, please notify us.

You agree not to reproduce, other than for your own personal, noncommercial use, all or part of this document on any medium whatsoever without permission of Schneider Electric, given in writing. You also agree not to establish any hypertext links to this document or its content. Schneider Electric does not grant any right or license for the personal and noncommercial use of the document or its content, except for a non-exclusive license to consult it on an "as is" basis, at your own risk. All other rights are reserved.

All pertinent state, regional, and local safety regulations must be observed when installing and using this product. For reasons of safety and to help ensure compliance with documented system data, only the manufacturer should perform repairs to components.

When devices are used for applications with technical safety requirements, the relevant instructions must be followed.

Failure to use Schneider Electric software or approved software with our hardware products may result in injury, harm, or improper operating results.

Failure to observe this information can result in injury or equipment damage.

© 2019 Schneider Electric. All rights reserved.

Table of Contents



	Safety Information	5
	About the Book	9
Chapter 1	Architectures	13
	Introduction	14
	Quantum Ethernet I/O Network Topologies	17
Chapter 2	Module Description	23
	Presentation	24
	LED Indicators	28
	General Specifications	29
	Mechanical and Electrical Specifications	31
	Standards and Certifications	32
Chapter 3	Module Installation	33
	Selecting Fiber Optic Cable	34
	Grounding Considerations	35
	Fitting of the Fiber Converter	36
	Installing Fiber Optic Cables	39
	Connecting the Fiber Converter to I/O Network Devices	42
	Module Configuration	48
Chapter 4	Maintenance	49
	Hot Swapping	50
	Troubleshooting	51
Glossary	55
Index	59

Safety Information



Important Information

NOTICE

Read these instructions carefully, and look at the equipment to become familiar with the device before trying to install, operate, service, or maintain it. The following special messages may appear throughout this documentation or on the equipment to warn of potential hazards or to call attention to information that clarifies or simplifies a procedure.



The addition of this symbol to a “Danger” or “Warning” safety label indicates that an electrical hazard exists which will result in personal injury if the instructions are not followed.



This is the safety alert symbol. It is used to alert you to potential personal injury hazards. Obey all safety messages that follow this symbol to avoid possible injury or death.

DANGER

DANGER indicates a hazardous situation which, if not avoided, **will result in** death or serious injury.

WARNING

WARNING indicates a hazardous situation which, if not avoided, **could result in** death or serious injury.

CAUTION

CAUTION indicates a hazardous situation which, if not avoided, **could result in** minor or moderate injury.

NOTICE

NOTICE is used to address practices not related to physical injury.

PLEASE NOTE

Electrical equipment should be installed, operated, serviced, and maintained only by qualified personnel. No responsibility is assumed by Schneider Electric for any consequences arising out of the use of this material.

A qualified person is one who has skills and knowledge related to the construction and operation of electrical equipment and its installation, and has received safety training to recognize and avoid the hazards involved.

BEFORE YOU BEGIN

Do not use this product on machinery lacking effective point-of-operation guarding. Lack of effective point-of-operation guarding on a machine can result in serious injury to the operator of that machine.

 WARNING
UNGUARDED EQUIPMENT
<ul style="list-style-type: none">• Do not use this software and related automation equipment on equipment which does not have point-of-operation protection.• Do not reach into machinery during operation.
Failure to follow these instructions can result in death, serious injury, or equipment damage.

This automation equipment and related software is used to control a variety of industrial processes. The type or model of automation equipment suitable for each application will vary depending on factors such as the control function required, degree of protection required, production methods, unusual conditions, government regulations, etc. In some applications, more than one processor may be required, as when backup redundancy is needed.

Only you, the user, machine builder or system integrator can be aware of all the conditions and factors present during setup, operation, and maintenance of the machine and, therefore, can determine the automation equipment and the related safeties and interlocks which can be properly used. When selecting automation and control equipment and related software for a particular application, you should refer to the applicable local and national standards and regulations. The National Safety Council's Accident Prevention Manual (nationally recognized in the United States of America) also provides much useful information.

In some applications, such as packaging machinery, additional operator protection such as point-of-operation guarding must be provided. This is necessary if the operator's hands and other parts of the body are free to enter the pinch points or other hazardous areas and serious injury can occur. Software products alone cannot protect an operator from injury. For this reason the software cannot be substituted for or take the place of point-of-operation protection.

Ensure that appropriate safeties and mechanical/electrical interlocks related to point-of-operation protection have been installed and are operational before placing the equipment into service. All interlocks and safeties related to point-of-operation protection must be coordinated with the related automation equipment and software programming.

NOTE: Coordination of safeties and mechanical/electrical interlocks for point-of-operation protection is outside the scope of the Function Block Library, System User Guide, or other implementation referenced in this documentation.

START-UP AND TEST

Before using electrical control and automation equipment for regular operation after installation, the system should be given a start-up test by qualified personnel to verify correct operation of the equipment. It is important that arrangements for such a check be made and that enough time is allowed to perform complete and satisfactory testing.

WARNING

EQUIPMENT OPERATION HAZARD

- Verify that all installation and set up procedures have been completed.
- Before operational tests are performed, remove all blocks or other temporary holding means used for shipment from all component devices.
- Remove tools, meters, and debris from equipment.

Failure to follow these instructions can result in death, serious injury, or equipment damage.

Follow all start-up tests recommended in the equipment documentation. Store all equipment documentation for future references.

Software testing must be done in both simulated and real environments.

Verify that the completed system is free from all short circuits and temporary grounds that are not installed according to local regulations (according to the National Electrical Code in the U.S.A, for instance). If high-potential voltage testing is necessary, follow recommendations in equipment documentation to prevent accidental equipment damage.

Before energizing equipment:

- Remove tools, meters, and debris from equipment.
- Close the equipment enclosure door.
- Remove all temporary grounds from incoming power lines.
- Perform all start-up tests recommended by the manufacturer.

OPERATION AND ADJUSTMENTS

The following precautions are from the NEMA Standards Publication ICS 7.1-1995 (English version prevails):

- Regardless of the care exercised in the design and manufacture of equipment or in the selection and ratings of components, there are hazards that can be encountered if such equipment is improperly operated.
- It is sometimes possible to misadjust the equipment and thus produce unsatisfactory or unsafe operation. Always use the manufacturer's instructions as a guide for functional adjustments. Personnel who have access to these adjustments should be familiar with the equipment manufacturer's instructions and the machinery used with the electrical equipment.
- Only those operational adjustments actually required by the operator should be accessible to the operator. Access to other controls should be restricted to prevent unauthorized changes in operating characteristics.

About the Book



At a Glance

Document Scope

This document is the reference guide for the Modicon X80 fiber converter modules BMXNRP0200, BMXNRP0200C and BMXNRP0201, BMXNRP0201C.

Validity Note

This document is valid for EcoStruxure™ Control Expert 14.1 or later.

The technical characteristics of the devices described in the present document also appear online. To access the information online:

Step	Action
1	Go to the Schneider Electric home page www.schneider-electric.com .
2	In the Search box type the reference of a product or the name of a product range. <ul style="list-style-type: none">• Do not include blank spaces in the reference or product range.• To get information on grouping similar modules, use asterisks (*).
3	If you entered a reference, go to the Product Datasheets search results and click on the reference that interests you. If you entered the name of a product range, go to the Product Ranges search results and click on the product range that interests you.
4	If more than one reference appears in the Products search results, click on the reference that interests you.
5	Depending on the size of your screen, you may need to scroll down to see the datasheet.
6	To save or print a datasheet as a .pdf file, click Download XXX product datasheet .

The characteristics that are presented in the present document should be the same as those characteristics that appear online. In line with our policy of constant improvement, we may revise content over time to improve clarity and accuracy. If you see a difference between the document and online information, use the online information as your reference.

Related Documents

Title of documentation	Reference number
Modicon M580, M340, and X80 I/O Platforms, Standards and Certifications	EIO0000002726 (English), EIO0000002727 (French), EIO0000002728 (German), EIO0000002730 (Italian), EIO0000002729 (Spanish), EIO0000002731 (Chinese)
Modicon X80 Racks and Power Supplies, Hardware, Reference Manual	EIO0000002626 (English), EIO0000002627 (French), EIO0000002628 (German), EIO0000002630 (Italian), EIO0000002629 (Spanish), EIO0000002631 (Chinese)
Quantum EIO, System Planning Guide	S1A48959 (English), S1A48961 (French), S1A48962 (German), S1A48964 (Italian), S1A48965 (Spanish), S1A48966 (Chinese)
Quantum EIO, Remote I/O Modules, Installation and Configuration Guide	S1A48978 (English), S1A48981 (French), S1A48982 (German), S1A48983 (Italian), S1A48984 (Spanish), S1A48985 (Chinese)
Modicon M340, Processors, Setup Manual	35012676 (English), 35012677 (French), 35013351 (German), 35013352 (Italian), 35013353 (Spanish), 35013354 (Chinese)

You can download these technical publications and other technical information from our website at www.schneider-electric.com/en/download.

Product Related Information

 **DANGER**

UNINTENDED EQUIPMENT OPERATION

The application of this product requires expertise in the design and programming of control systems. Only persons with such expertise should be allowed to program, install, alter, and apply this product.

Follow all local and national safety codes and standards.

Failure to follow these instructions will result in death or serious injury.

Chapter 1

Architectures

Overview

This chapter provides general information on Quantum Ethernet I/O (EIO) architectures, where Modicon X80 BMXNRP020• fiber converters can be used to support fiber optic cables on the daisy chain loop.

What Is in This Chapter?

This chapter contains the following topics:

Topic	Page
Introduction	14
Quantum Ethernet I/O Network Topologies	17

Introduction

Overview

The BMXNRP020• are fiber optic converters that work in a Quantum Ethernet I/O (EIO) architecture. These modules enable to connect X80 remote I/O drops and Quantum EIO drops to the main ring of the Quantum EIO network on fiber optic cable without the need to use dual-ring switches (DRSs) for the copper-fiber conversion.

There are 2 models of fiber converters each supporting one type of fiber optic cable:

- BMXNRP0200 and BMXNRP0200C support multimode fiber cable for distances up to 1.24 mi (2 km).
- BMXNRP0201 and BMXNRP0201C support single-mode fiber cable for distances up to 9.32 mi (15 km).

Quantum Ethernet I/O Networks

Using Ethernet as a backbone, the PLC communicates with remote I/O drops and/or distributed I/O devices dispersed through the network via a Quantum CRP head module installed in the local rack and adapter modules (Quantum 140 CRA or Modicon X80 CRA) installed in I/O drops using copper cable. While DRSs enable the use of fiber cable, they also allow you to connect sub-rings to the main ring and to connect distributed I/O devices to the remote I/O network. DRSs need to be configured.

You can use BMXNRP020• fiber converters for the copper to fiber conversion and vice versa.

The BMXNRP020• fiber converters install on a local extended rack between the local rack Quantum CRP head module and next to each remote X80 CRA adapter module on the main ring.

On the local extended rack, the fiber converter works with the Quantum CRP head module. It allows:

- a copper-to-fiber connection.
- a fiber-to-fiber connection, where the optical link connects the fiber converter on the local extended rack to the fiber converters on the daisy chain.

On the remote I/O drop, the fiber converter works with the Quantum 140 CRA and Modicon X80 CRA adapter modules. It allows:

- a fiber-to-fiber connection with daisy chain loop management.
- a fiber-to-copper connection with daisy chain loop management, where the optical link connects to the fiber converter and the copper link connects to the CRA module.

The BMXNRP020• fiber converters allow an indication of communication disruption to be sent back through the network so that the system can recover within 50 ms.

The BMXNRP020• fiber converters mount on the Modicon X80 backplanes (*see Modicon X80, Racks and Power Supplies, Hardware Reference Manual*).

The following figure shows the installation of BMXNRP020• fiber converters throughout a Quantum EIO network:

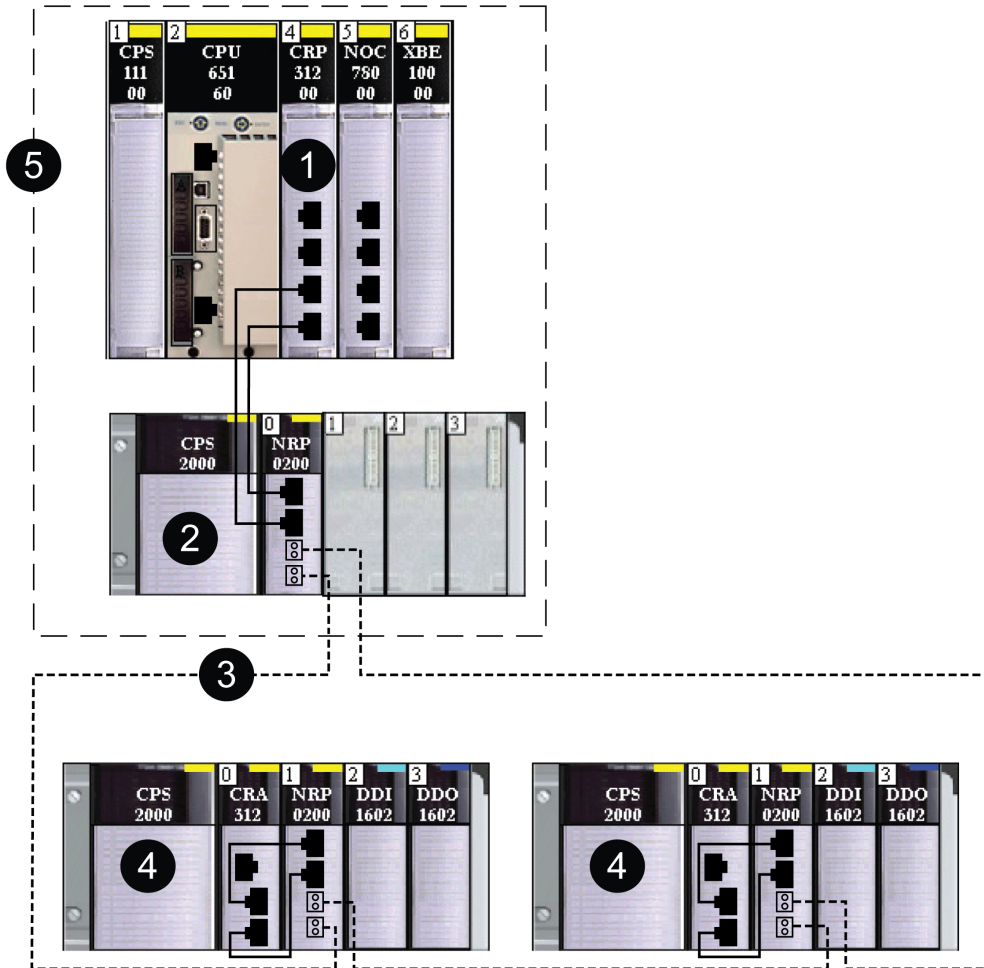

--- fiber cable

— copper cable

- 1 140CRP31200 remote I/O head module on the local rack connected via copper cable to a RJ45 Ethernet port of a BMXNRP020• fiber converter
- 2 BMXNRP020• fiber converter connected via copper cable to the 140CRP31200 module and connected via fiber cable to the BMXNRP020• fiber converter on a subsequent X80 drop
- 3 fiber portion of the main ring
- 4 X80 drops connected to the main ring via fiber cable using a BMXNRP020• fiber converter
- 5 local rack area with local main rack and local extended rack

In the example above, a fiber converter is installed in a local extended rack, allowing you to run copper cables from the Quantum 140 CRP head module to the fiber converter. From there, a fiber converter is installed in each X80 remote I/O drop so that all the X80 remote I/O drops are connected by fiber optic cable.

Fiber optic cable enables you to:

- separate the remote I/O drops from one another by distances greater than 328 ft (100 m). The maximum distances are:
 - 1.24 mi (2 km) for multimode fiber
 - 9.32 mi (15 km) for single-mode fiber
- carry control signals more effectively through noisy environments

For more details, refer to chapter *Planning a Simple Daisy Chain Loop* (see *Quantum EIO, System Planning Guide*).

Quantum Ethernet I/O Network Topologies

Overview

The insertion of BMXNRP020• fiber converters in a Quantum EIO network enables conversion from copper cable to fiber optic cable and the other way around in different network topologies.

NOTE: A fiber converter does not count as a device in your main ring capacity calculation.

Connecting to X80 and Quantum EIO Drops

Use BMXNRP020• fiber converters to connect one or more Quantum EIO drops to a fiber main I/O ring with daisy chain loop management:

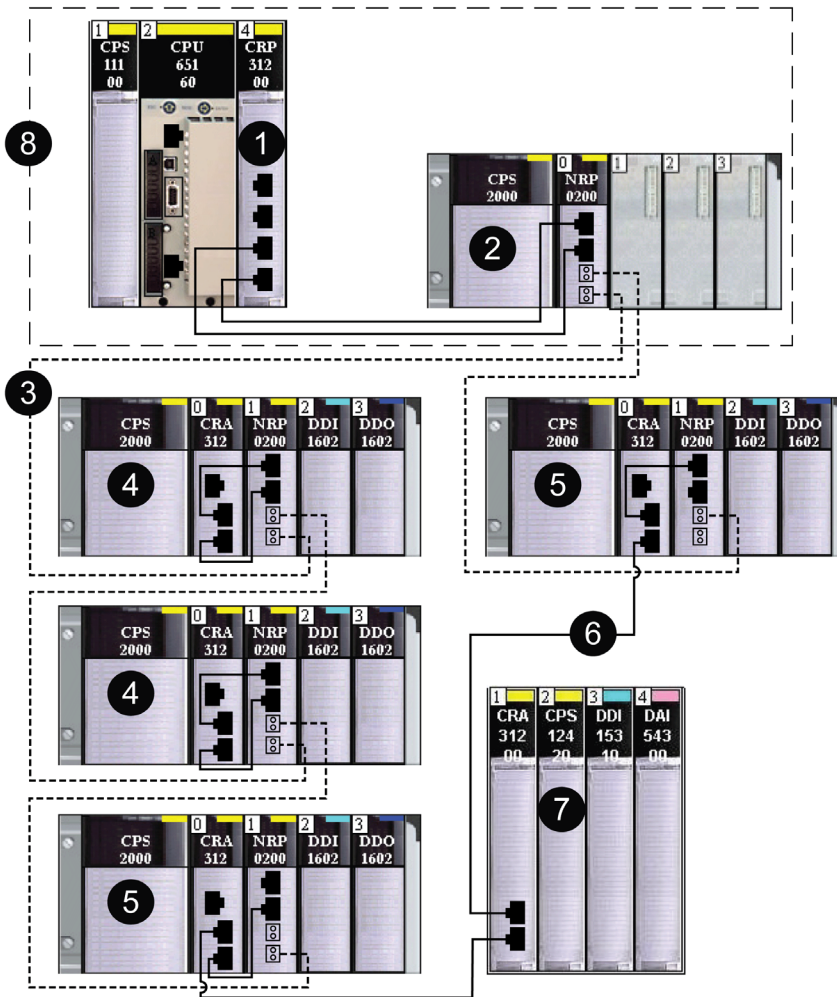

--- fiber cable
 — copper cable

- 1 140CRP31200 remote I/O head module on the local rack connected via copper cable to a transceiver port of a BMXNRP020• fiber converter
- 2 BMXNRP020• fiber converter connected via copper cable to the 140CRP31200 head module and connected via fiber cable to the BMXNRP020• fiber converter on a subsequent X80 drop
- 3 fiber portion of the main ring
- 4 X80 drops connected to the main ring via fiber cable

- 5 X80 drop connected to the main ring via fiber and copper cable — the BMXNRP020• fiber converter connects the drop to the main ring via fiber, and the BMXCRA31200 adapter module connects the Quantum EIO drop to the main ring via copper cable
- 6 copper portion of the main ring
- 7 Quantum EIO drop connected to the main ring via copper cable (No BMXNRP020• fiber converter is required.)
- 8 Local area with local main rack and local extended rack

Fiber Connection Between a Quantum Main Rack and Quantum EIO Drops

Use BMXNRP020• fiber converters to connect one or more Quantum EIO drops with daisy chain loop management:

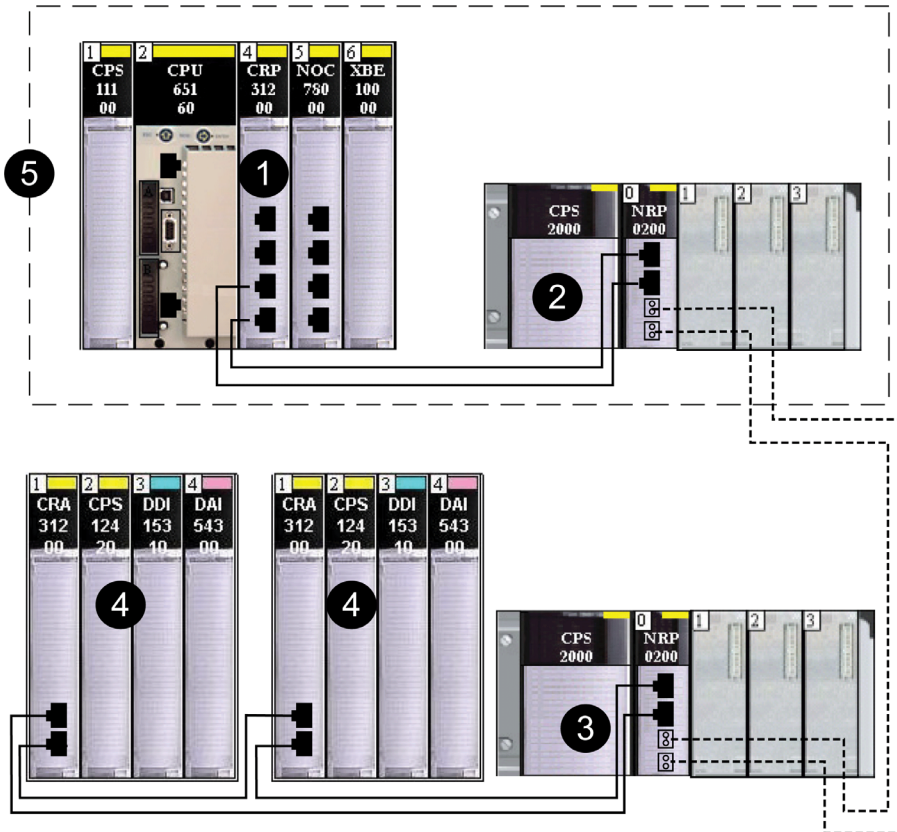

--- fiber cable

— copper cable

- 1 140CRP31200 remote I/O head module on the local rack connected via copper cable to a transceiver port of a BMXNRP020• fiber converter
- 2 BMXNRP020• fiber converter connected via copper cable to the 140CRP31200 head module and connected via fiber cable to the BMXNRP020• fiber converter on a subsequent X80 drop

- 3 BMXNRP020• fiber converter connected via copper cable to the 140CRA31200 drop module(s) and connected via fiber cable to the BMXNRP020• fiber converter
- 4 Quantum EIO drop connected to the main ring via copper cable
- 5 Local area with local main rack and local extended rack

Creating a Long-Haul Hot Standby Link

The following graphic shows the installation of BMXNRP020• fiber converters to extend the distance between the 2 PLCs beyond 328 ft (100 m):

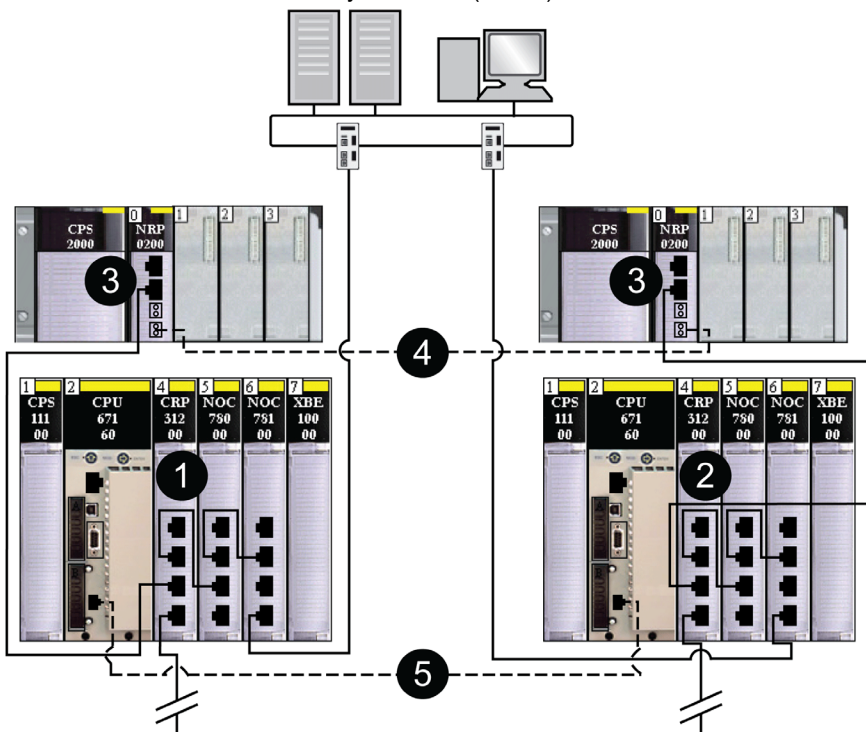

- 1 140CRP31200 remote I/O head module on the primary Hot Standby PLC connected to a copper port of a BMXNRP020• fiber converter
- 2 140CRP31200 remote I/O head module on the secondary Hot Standby PLC connected to a copper port of a BMXNRP020• fiber converter
- 3 BMXNRP020• fiber converters on local extended racks connected via copper cable to 140CRP31200 head modules on the local racks
- 4 fiber cable connected to the fiber ports of the BMXNRP020• fiber converters to extend the distance between the Hot Standby PLCs beyond 328 ft (100 m)
- 5 fiber cable used for the CPU-sync link

NOTE: Connect the fiber optic cable between the 2 fiber converters (3) straight through. No EIO drops are allowed on this link.

High-Capacity Daisy Chain Loop Topology

Use BMXNRP020• fiber converters to extend the distance between the main local rack and sub-rings or distributed I/O devices beyond 328 ft (100 m).

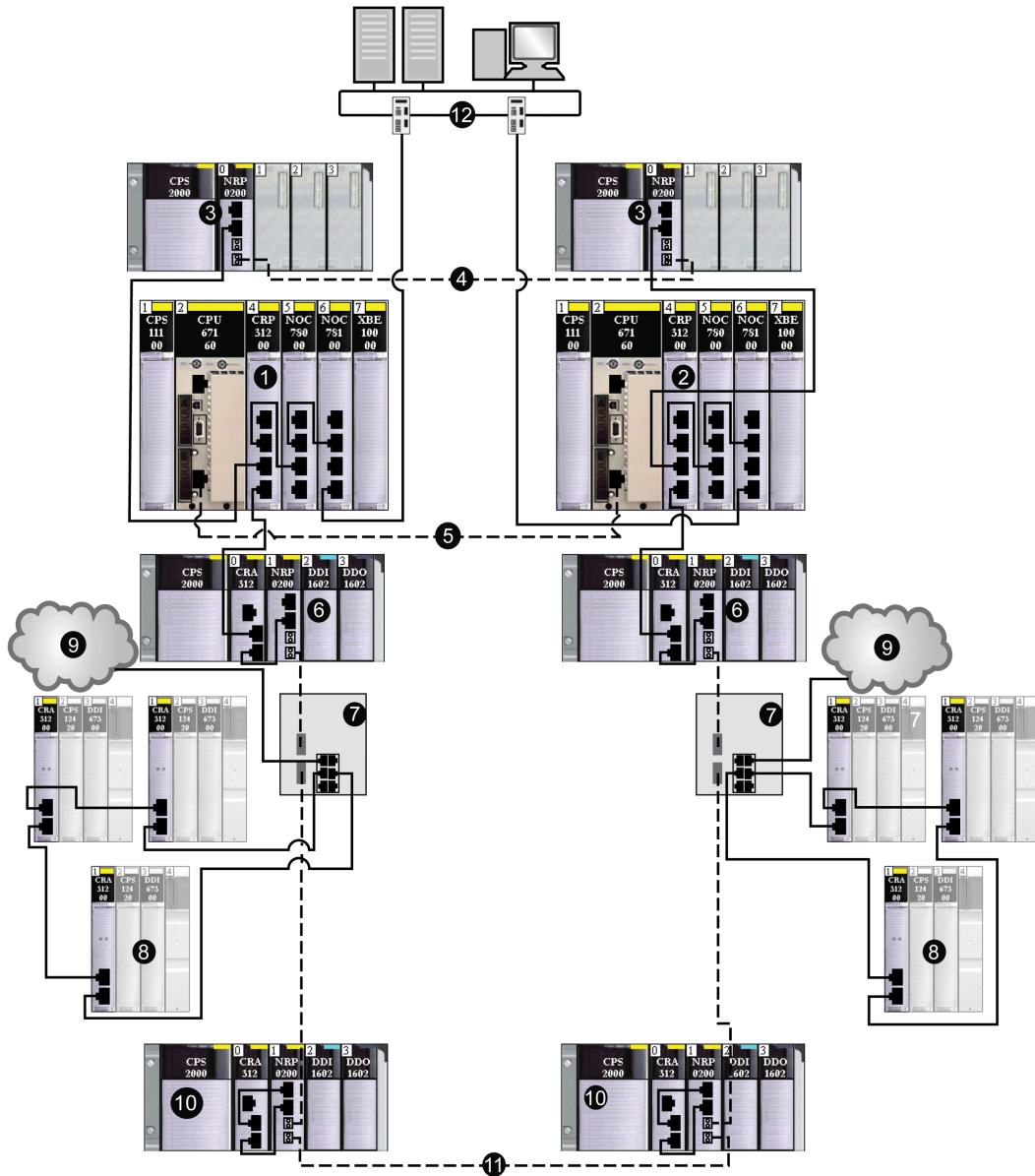

--- fiber cable

— copper cable

- 1 140CRP31200 remote I/O head module on the primary Hot Standby PLC connected to a copper port of a BMXNRP020• fiber converter
- 2 140CRP31200 remote I/O head module on the secondary Hot Standby PLC connected to a copper port of a BMXNRP020• fiber converter
- 3 BMXNRP020• fiber converters on extended local racks connected via copper cable to 140CRP31200 head modules on the local racks
- 4 fiber cable connected to the fiber ports of the BMXNRP020• fiber converters to extend the distance between the Hot Standby PLCs beyond 328 ft (100 m)
- 5 fiber cable used for the CPU-sync link
- 6 BMXNRP020• fiber converters on X80 Ethernet remote I/O drops connected to DRSs via fiber cable
- 7 DRSs (with a C3 predefined configuration file) connecting Quantum Ethernet remote I/O sub-rings and distributed I/O clouds to the main ring via copper cable
- 8 Quantum Ethernet remote I/O sub-rings
- 9 distributed I/O clouds
- 10 BMXNRP020• fiber converters on X80 Ethernet remote I/O drops connected to DRSs via fiber cable and connected to each other
- 11 fiber cable connecting two X80 Ethernet remote I/O drops to extend the distance beyond 100 m
- 12 control network

For more details, refer to chapter *Planning a High-Capacity Daisy Chain Loop* (see *Quantum EIO, System Planning Guide*).

NOTE: You can install BMXNRP020• fiber converters on the main ring and sub-rings for copper-to-fiber conversion and vice-versa. However, you cannot use these modules to connect sub-rings to the main.

Chapter 2

Module Description

Overview

This chapter provides a general description of the BMXNRP020• fiber converters.

What Is in This Chapter?

This chapter contains the following topics:

Topic	Page
Presentation	24
LED Indicators	28
General Specifications	29
Mechanical and Electrical Specifications	31
Standards and Certifications	32

Presentation

Overview

The BMXNRP020• fiber converters provide communication between 2 or more Quantum EIO nodes or segments of networks over fiber optic cables. Each fiber converter has 2 Ethernet network interfaces and 2 fiber optic interfaces for media conversion from copper to fiber and fiber to copper. The maximum forward delay of one media converter is 5 μ s.

The BMXNRP020• fiber converters are simple networking devices without network management functions. Therefore, the modules do not support communication through the backplane connector.

Power is supplied from the rack.

Module References

Based on the fiber optic interface there are 2 models of X80 fiber converters:

- Use a BMXNRP0200 or BMXNRP0200C with multimode fiber for distances up to 1.24 mi (2 km).
- Use a BMXNRP0201 or BMXNRP0201C with single-mode fiber for distances up to 9.32 mi (15 km).

The BMXNRP0200C and BMXNRP0201C (coated) equipments are ruggedized version of respectively BMXNRP0200 and BMXNRP0201 standard versions.

The ruggedized BMXNRP0200C and BMXNRP0201C equipments have the same performance characteristics as the standard BMXNRP0200 and BMXNRP0201 equipments.

The **ruggedized** versions can be used at extended temperatures -25...60 °C (-13...140 °F) and in harsh chemical environments. If the ruggedized equipments are operated outside the -25...60 °C (-13...140 °F) temperature range, they can operate abnormally.

The **standard** versions can be used at standard temperatures 0...60 °C (32...140 °F). If the standard equipments are operated outside the 0...60 °C (32...140 °F) temperature range, they can operate abnormally.

CAUTION

UNINTENDED EQUIPMENT OPERATION

Do not operate equipment outside of its specified temperature range.

Failure to follow these instructions can result in injury or equipment damage.

For more information, refer to chapter *Installation in More Severe Environments* (see *Modicon M580, M340, and X80 I/O Platforms, Standards and Certifications*).

Altitude Operating Conditions

The characteristics apply to the modules BMXNRP020• for use at altitude up to 2000 m (6560 ft). When the modules operate above 2000 m (6560 ft), apply additional derating.

For detailed information, refer to chapter *Operating and Storage Conditions* (see *Modicon M580, M340, and X80 I/O Platforms, Standards and Certifications*).

Module Description

The following graphic shows the BMXNRP020• fiber converter front panel:

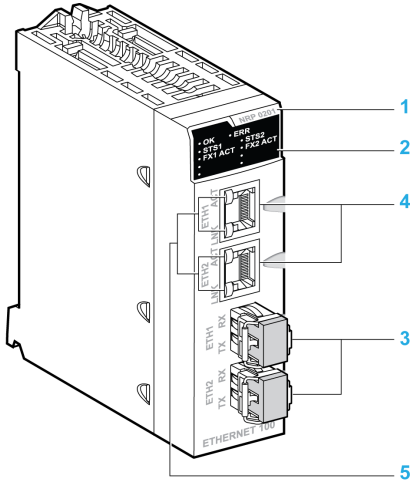

- 1 Model number
- 2 LED display panel
- 3 Optical port with SFP transceiver for LC-type connector
- 4 RJ45 Ethernet port
- 5 **LNK** and **ACT** LED indicators on the RJ45 Ethernet port

NOTICE

INOPERABLE EQUIPMENT

Do not remove the protective covers from unused optical ports on this fiber converter.

Failure to follow these instructions can result in equipment damage.

Ethernet Ports

The BMXNRP020• fiber converters are equipped with two 100BaseT(X), full duplex, and auto MDI/MDX Ethernet ports without MAC address. The connectors are mechanically tied to the module ground.

The fiber converter uses copper cable for Ethernet connection with the maximum distance limitation of 328 ft (100 m).

The 2 LEDs, **LNK** and **ACT** embedded on each Ethernet port indicate the connection status and link speed of the communication.

- **LNK** LED lighting green: link established at 100 Mbps
- **ACT** LED lighting green: connection is active

The following table describes the pinout details of the RJ45 Ethernet 100BaseT connector:

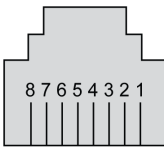
Pin Connection	Pin	Signal
	1	TD+
	2	TD-
	3	RD+
	4	N.C
	5	N.C
	6	RD-
	7	N.C
	8	N.C
	Shell	Chassis ground

Optical Ports

The BMXNRP020• fiber converters are equipped with 2 optical ports. Each port has a SFP transceiver module. One pair of fiber optic cables is connected to one optical port using an LC-type duplex connector (one connector for the transmitter signal (**Tx**) and one connector for the receiver signal (**Rx**)).

The optical ports of the BMXNRP0200, BMXNRP0200C fiber converters receive SFP multimode transceivers that support 100BaseFX, an LC-type connector, and multimode fiber of 62.5/125 μm and 50/125 μm .

The optical ports of the BMXNRP0201, BMXNRP0201C fiber converters receive SFP single-mode transceivers that support 100BaseFX, an LC-type connector, and single-mode fiber of 9/125 μm .

NOTICE

INOPERABLE EQUIPMENT

Do not unplug a SFP transceiver or insert third party SFP transceivers in the optical port of BMXNRP020• fiber converters.

Failure to follow these instructions can result in equipment damage.

LED Indicators

LED Display Panel

The following figure shows the LED indicators of the BMXNRP020• fiber converters:



The following table describes the LED indicators on the LED display panel:

LED Label	Color	Description
OK	Green	Status of the power supply
ERR	Red	A detected error on a module or channel
STS1/STS2	Green	The link status of the respective fiber connection
FX1 ACT/FX2 ACT	Green	The communication status of the respective fiber connection

LED Display Panel and RJ45 LED Indicators

The following table describes the behavior of LED indicators:

OK	ERR	STS1/STS2	FX1 ACT/ FX2 ACT	ETH1/ ETH2 LNK	ETH1/ ETH2 ACT	Description
OFF	OFF	OFF	OFF	OFF	OFF	Power off
ON	ON	ON	ON	ON	ON	Self testing
ON	OFF	OFF	OFF	OFF	OFF	Initial power on without link
ON	OFF	FLK	OFF	OFF	OFF	Fiber cable break ¹
ON	OFF	ON	OFF	OFF	OFF	Copper cable break ²
ON	OFF	ON	ON	ON	ON	Copper and fiber cables connected without data
ON	OFF	ON	FLK	ON	FLK	Copper and fiber cables connected with data
ON	ON	FLK	OFF	OFF	OFF	SFP/Fiber PHY breakdown
ON	ON	ON	OFF	OFF	OFF	Copper PHY breakdown

¹ when the fiber optic cable breaks, LED of STS is flickering. If the copper cable is plugged off, LED display keeps the same and does not indicate the copper cable is unplugged.

² when the copper cable breaks, LED of STS is on. If the fiber optic cable is plugged off, LED display keeps the same and fiber converter cannot sense the fiber optic cable plug off.

General Specifications

Introduction

This section gives the BMXNRP020• fiber converter specifications.

WARNING

UNINTENDED EQUIPMENT OPERATION

Do not exceed any of the rated values specified in the following tables.

Failure to follow these instructions can result in death, serious injury, or equipment damage.

General Specifications

Characteristics	BMXNRP0200 and BMXNRP0200C	BMXNRP0201 and BMXNRP0201C
Power Consumption in BKP 24 Vdc	140 mA (200 mA maximum)	
Hot Swapping	Supported	
RJ45 Ethernet Ports	2 ports compliant with IEEE802.3u 100BaseT(X)	
Optical Ports	2 ports compliant with IEEE802.3u 100Base-FX	
Wavelength	1310 nm	
Fiber Size	50/125 μm 62.5/125 μm	9/125 μm
Maximum Distance	0...6,562 ft (0...2 km)	up to 49,213 ft (15 km)

Optical Transmitter Specifications

Characteristics	BMXNRP0200 and BMXNRP0200C	BMXNRP0201 and BMXNRP0201C
Optical Power	-23.5...-14 dBm with 50/125 μm fiber cable -20...-14 dBm with 62.5/125 μm fiber cable	-15...-8 dBm with 9/125 μm fiber cable
Rise/Fall Time	3 ns or better	2.5 ns or better
Transmitter Disable Off Power	-45 dBm maximum	

Optical Receiver Specifications

Characteristics	BMXNRP0200 and BMXNRP0200C	BMXNRP0201 and BMXNRP0201C
Receiver Sensitivity	-31...-14 dBm	-31...-8 dBm
Loss of Signal Deassert	-32 dBm maximum	-31.5 dBm maximum

Mechanical and Electrical Specifications

Mechanical Specifications

Weight	7.16 oz (203 g)
Dimensions (H x D x W)	3.94 x 3.39 x 1.26 in. (100 x 86 x 32 mm)
Space Requirements	1 backplane slot

The following graphic shows the space requirements of the BMXNRP020• fiber converters:

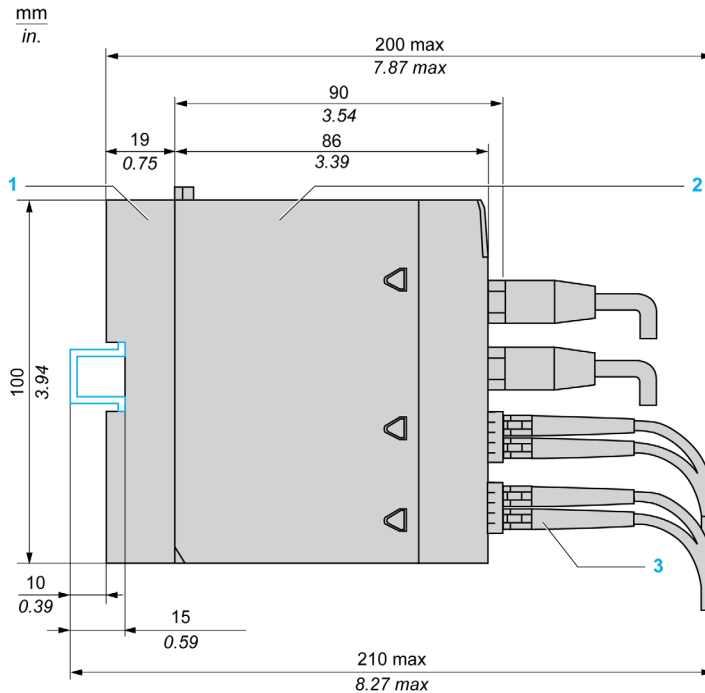

Electrical Specifications

Voltage	24 Vdc
Dielectric Strength	Field to bus: 1400 Vdc Channel to channel: 500 Vdc
Protection Offered by Enclosure	IP20

Standards and Certifications

Download

Click the link that corresponds to your preferred language to download standards and certifications (PDF format) that apply to the modules in this product line:

Title	Languages
Modicon M580, M340, and X80 I/O Platforms, Standards and Certifications	<ul style="list-style-type: none"><li data-bbox="648 386 920 410">● English: EIO0000002726<li data-bbox="648 414 920 438">● French: EIO0000002727<li data-bbox="648 441 920 466">● German: EIO0000002728<li data-bbox="648 469 920 493">● Italian: EIO0000002730<li data-bbox="648 496 920 521">● Spanish: EIO0000002729<li data-bbox="648 524 920 548">● Chinese: EIO0000002731

Chapter 3

Module Installation

Overview

This chapter provides information on installing BMXNRP020• fiber converters in an EIO Network.

What Is in This Chapter?

This chapter contains the following topics:

Topic	Page
Selecting Fiber Optic Cable	34
Grounding Considerations	35
Fitting of the Fiber Converter	36
Installing Fiber Optic Cables	39
Connecting the Fiber Converter to I/O Network Devices	42
Module Configuration	48

Selecting Fiber Optic Cable

Overview

If you are using BMXNRP020• fiber converters in your Quantum EIO network, there are several parameters that you have to consider. Some of those parameters are cable attenuation and cable bandwidth.

Parameters are specified by the cable manufacturer and are based on:

- the wavelength of the optical signal: 1310 nm in the Quantum EIO optical link
- the cable index: use graded-index cable only
- the fiber size:
 - 50/125 μm or 62.5/125 μm
 - 9/125 μm

For most multimode optical cable links, the use of 62.5/125 μm cable is recommended because of its relatively low loss and signal distortion.

- Select the fiber optic cable that meets the demands of your application. Multiconductor cables are recommended.
- Most 62.5/125 μm cables are rated at 1.5 dB loss per km. With a multiconductor cable, pairs come with an attenuation specification as measured, which is less than 3.5 dB/km.

Grounding Considerations

General

Proper grounding of Modicon X80 modules is crucial to avoid electric shocks.

Grounding Fiber Converter Modules

The BMXNRP020• fiber converter modules are equipped with contacts strips at the rear for grounding purposes:

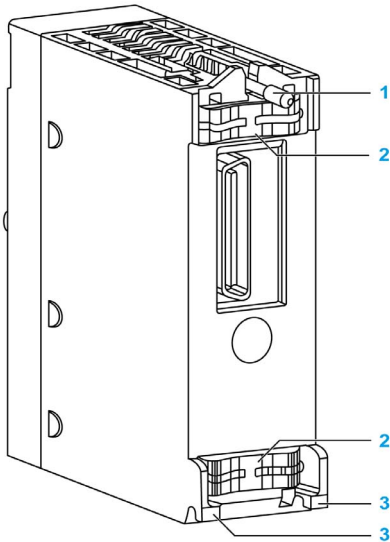

- 1 Mounting screw
- 2 Contact strips
- 3 Locating pins

When the module is correctly installed on the rack, the contact strips connect the grounding bus of the module to the grounding bus of the rack (*see Modicon X80, Racks and Power Supplies, Hardware Reference Manual*).

⚠ DANGER

HAZARD OF ELECTRIC SHOCK

Check that ground contact strips are available and not bent out of shape.

Failure to follow these instructions will result in death or serious injury.

NOTE: If ground contacts strips are bent or not available, do not use the module and contact your Schneider Electric representative.

Fitting of the Fiber Converter

At a Glance

The BMXNRP020• fiber converters are powered by the bus of the rack.

Fitting operations (installation, assembly, and disassembly) are described below.

Installation Precautions

The BMXNRP020• fiber converters may be installed in any slot in the rack except:

- on EIO drop, BMX NRP module can be mounted starting from the fourth slot. The first 3 slots in the X80 drop are reserved for the rack's power supply module (BMXCPS••••) and the Modicon X80 CRA adapter module (BM•CRA312•0).
- on local extended rack, BMX NRP module can be mounted starting from third slot. The first 2 slots in the subsequent X80 drop are reserved for the rack's power supply module (BMXCPS••••).

Power is supplied by the rack. No additional power is needed.

Before installing a fiber converter, you must take off the protective cap from the module connector located on the rack.

DANGER

SEVERE EYE DAMAGE

Do not view the ends of fiber optic cable under magnification while a transmit signal is present on the cable.

Failure to follow these instructions will result in death or serious injury.

NOTICE

INOPERABLE EQUIPMENT

Do not remove the protective coverings from the optical cable port and optical cable tips until immediately fiber cable connection to the cable port.

After removing the protective coverings, never touch exposed parts such as the ferrule.

After connecting the fiber cable, retain the protective coverings for future use.

Do not remove the protective covering from the unused connector.

Failure to follow these instructions can result in equipment damage.

Fiber Cable Preparation

Before installing BMXNRP020• fiber converters, optical network cables must be prepared.

To prepare fiber optic cables:

- Follow the cable manufacturer's recommendations for routing, installing, and testing the cable. Take care when terminating the ends of each fiber optic cable in order to minimize loss of optical signal. Follow the manufacturers guidelines for installing optical connectors.
- Test the cable for proper attenuation before the connection of the fiber converters. The cable ends has to be accessible at each fiber optic installation site. Allow sufficient cable length for a service loop and strain reliefs.
- Label each cable end to facilitate future maintenance.

NOTICE

INOPERABLE EQUIPMENT

Do not unplug a SFP transceiver or insert third party SFP transceivers in the BMXNRP020• fiber converters.

Failure to follow these instructions can result in equipment damage.

Installing the Fiber Converter on the Rack

The following table shows the procedure for mounting the fiber converter module in the rack.

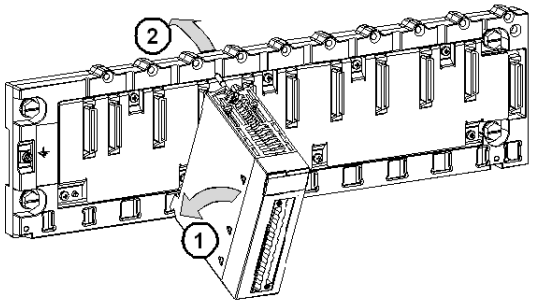
Step	Action	Illustration
1	Position the locating pins situated at the rear of the module (on the bottom part) in the corresponding slots in the rack. Before positioning the pins, make sure you have removed the protective cover.	 <p>The illustration shows a perspective view of a fiber converter module being inserted into a rack. The module is a rectangular unit with a front panel and a rear panel. The rear panel has several vertical slots and a central connector. The rack has corresponding slots and a screw mechanism. Step 1 is indicated by a circular callout '1' pointing to the bottom of the module as it is being inserted into the rack. Step 2 is indicated by a circular callout '2' pointing to the top of the module as it is being secured by a screw.</p>
2	Swivel the module towards the top of the rack so that the module sits flush with the back of the rack. It is now set in position.	

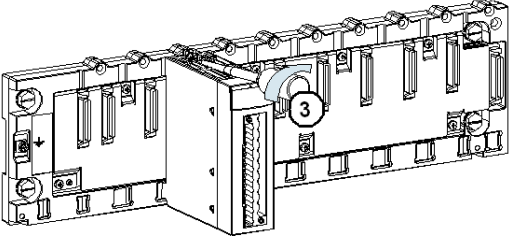
Step	Action	Illustration
3	<p>Tighten the mounting screw to hold in place on the rack. Tightening torque: 0.4...1.5 N•m (0.29...1.10 lb-ft).</p>	<p>Step 3</p> 

⚠ WARNING

UNINTENDED EQUIPMENT OPERATION

Check that the mounting screw is securely tightened to ensure the module is firmly attached to the rack.

Failure to follow these instructions can result in death, serious injury, or equipment damage.

Installing Fiber Optic Cables

Observing Safety Precautions

Before connecting the fiber optic cables to the BMXNRP020• fiber converter, read the following messages. Follow them at all times during the installation of the fiber optic cables.

DANGER

SEVERE EYE DAMAGE

Do not view the ends of fiber optic cable under magnification while a transmit signal is present on the cable.

Failure to follow these instructions will result in death or serious injury.

NOTICE

INOPERABLE EQUIPMENT

Do not remove the protective coverings from the optical cable port and optical cable tips until immediately fiber cable connection to the cable port.

After removing the protective coverings, never touch exposed parts such as the ferrule.

After connecting the fiber cable, retain the protective coverings for future use.

Do not remove the protective covering from the unused connector.

Failure to follow these instructions can result in equipment damage.

Installing Fiber Optic Cables

Connect the fiber optic cable to the SFP transceiver module as described in the following table:

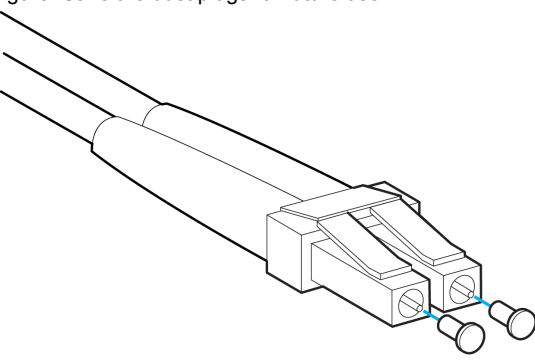
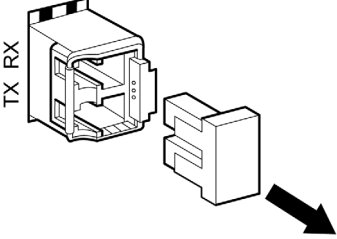
Step	Action
1	<p>Remove the dust plugs from the LC connectors of the fiber optic cable as shown in the following figure. Save the dust plugs for future use.</p> 
2	<p>Inspect and clean the fiber optic end faces of the LC connectors.</p>
3	<p>Remove the dust plug from the SFP transceiver module as shown in the following figure.</p> 

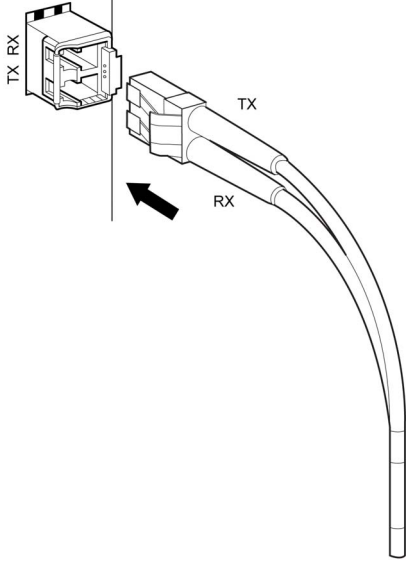
Step	Action
4	<p data-bbox="319 204 1249 256">Immediately attach the LC connector of the fiber optic cable to the SFP transceiver module as shown in following figure.</p> 

NOTE: Do not remove the SFP transceiver modules from the BMXNRP020• fiber converters as shown in the following figure.

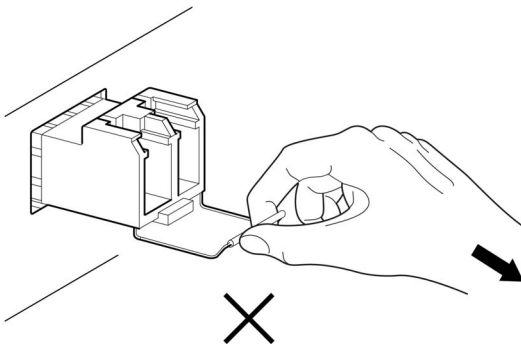

Connecting the Fiber Converter to I/O Network Devices

Overview

Connections on the BMXNRP020• fiber converters vary depending on the network topology and the position of the fiber converters on the network.

The fiber converters can be connected to:

- a Quantum CRP head module when installed on the local extended rack
- a Quantum CRP head module in a long-haul Hot Standby configuration
- a Quantum or a Modicon X80 CRA adapter module
- a DRS in a high-capacity daisy chain loop topology

Connecting to a 140CRP31200 Head Module

The following graphic shows connections of the BMXNRP020• fiber converter on the local extended rack to the 140CRP31200 head module on the local main rack in a simple daisy chain loop topology (*see page 18*):

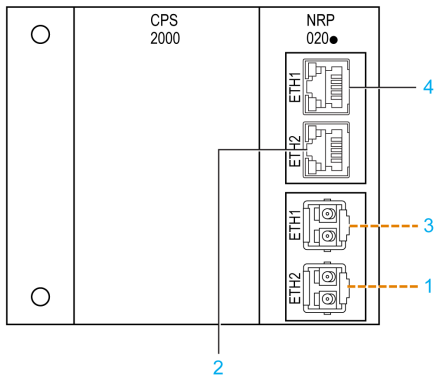

--- fiber cable

— copper cable

- 1 fiber cable connected to the ETH2 optical port of the BMXNRP020• fiber converter on the subsequent EIO drop on the main ring
- 2 copper cable connected to the ETH4 RJ45 port of the 140CRP31200 head module on the local main rack
- 3 fiber cable connected to the ETH1 optical port of the BMXNRP020• fiber converter on the last EIO drop on the main ring
- 4 copper cable connected to the ETH3 RJ45 port of the 140CRP31200 head module on the local main rack

For more information, please refer to Characteristics of Ethernet Remote I/O Modules (*see Quantum EIO, Remote I/O Modules, Installation and Configuration Guide*).

Connecting to a 140CRP31200 Head Module in a Long-Haul Hot Standby Configuration

The following graphic shows connections of the BMXNRP020• fiber converter to the 140CRP31200 head module on the primary and secondary main racks (*see page 20*):

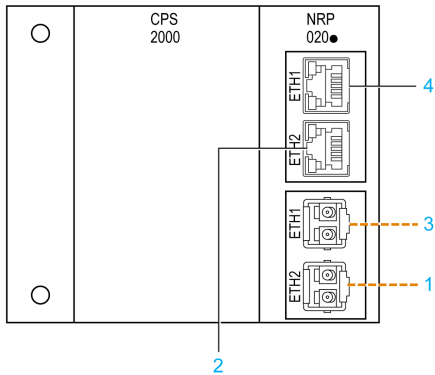

--- fiber cable

— copper cable

- 1 fiber cable connecting the ETH2 optical port of the BMXNRP020• fiber converters on the primary and secondary local extended racks
- 2 copper cable connected to the ETH3 RJ45 port of the 140CRP31200 head modules on the primary and secondary local main racks
- 3 not used
- 4 not used

NOTE: Connect the fiber optic cable between the 2 fiber converters straight through. No EIO drops are allowed on this link.

Connecting to a Modicon X80 BMXCRA312•• Module

The following graphic shows connections between the BMXNRP020• fiber converter and the BMXCRA312•• on X80 EIO drop:

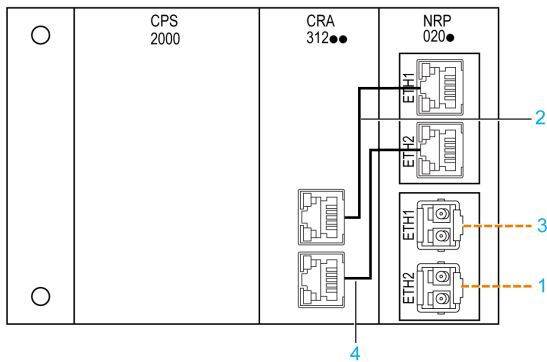

--- fiber cable

— copper cable

- 1 fiber cable connected to the ETH2 optical port of the BMXNRP020• fiber converter on the subsequent EIO drop on the main ring
- 2 copper cable connected to the ETH2 RJ45 port of the BMXCRA312•• fiber converter on the X80 EIO drop
- 3 fiber cable connected to the ETH1 optical port of the BMXNRP020• fiber converter on the previous EIO drop on the main ring
- 4 copper cable connected to the ETH3 RJ45 port of the BMXCRA312•• fiber converter on the X80 EIO drop

NOTE: The shortest length of copper cable used to connect the RJ45 Ethernet ports of a NRP and a CRA module is 3.28 ft (1 m).

For more information, please refer to Characteristics of Ethernet Remote I/O Modules (see *Quantum EIO, Remote I/O Modules, Installation and Configuration Guide*).

Connecting to a 140CRA31200 Module

The following graphic shows connections of the BMXNRP020• fiber converter to the 140CRA31200 adapter module installed on a Quantum EIO drop connected to the copper portion of the main ring:

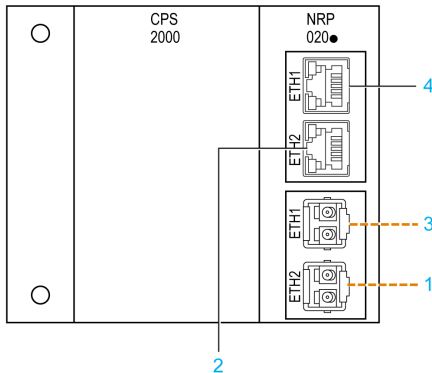

--- fiber cable

— copper cable

- 1 fiber cable connected to the ETH1 optical port of the BMXNRP020• fiber converter on the local extended rack
- 2 copper cable connected to the ETH2 RJ45 port of the 140CRA31200 module on the Quantum EIO drop
- 3 fiber cable connected to the ETH2 optical port of the BMXNRP020• fiber converter on the local extended rack
- 4 copper cable connected to the ETH3 RJ45 port of the 140CRA31200 module on the Quantum EIO drop

For more information, please refer to Characteristics of Ethernet Remote I/O Modules (see *Quantum EIO, Remote I/O Modules, Installation and Configuration Guide*).

Connecting to a DRS in a High-Capacity Daisy Chain Loop Topology

The following graphic shows connections of the BMXNRP020• fiber converter to a DRS to extend the distance between the DRS and the local main rack (*see page 21*) beyond 328 ft (100 m):

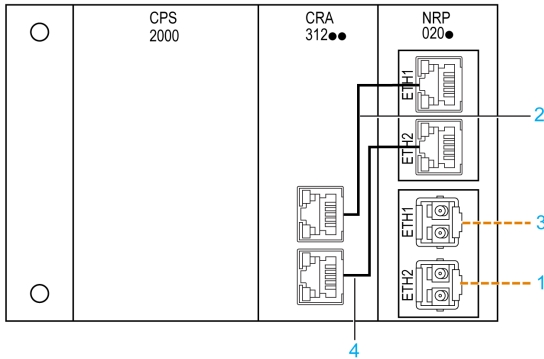

--- fiber cable

— copper cable

- 1 fiber cable connected to the optical port (1) of the DRS
- 2 copper cable connected to the ETH4 RJ45 port of the 140CRP31200 head module on the local main rack
- 3 fiber cable connected to the ETH2 optical port of the BMXNRP020• fiber converter on the local extended rack
- 4 copper cable connected to the ETH3 RJ45 port of the BMXCRA312•• adapter module on the X80 EIO drop

NOTE: The optical port (2) (*see Quantum EIO, System Planning Guide*) of the DRS is connected via fiber cable to the ETH1 optical port of the BMXNRP020• fiber converter installed on the subesquent drop on the main ring.

NOTE: Apply predefined configuration settings C3 or C4 to the DRS in this topology. For more details, refer to chapter Predefined Configuration Files (*see Quantum EIO, System Planning Guide*).

Applying Power

Before applying power to the backplane, verify that all power connections, electrical cable connections, and fiber optic connections are correctly installed for your application.

For more information, refer to *Modicon X80, Racks and Power Supplies, Hardware Reference Manual*

When the backplane power is applied to the BMXNRP020• fiber converters, the LED **OK** illuminates LED indicators (*see page 28*).

Reading the Network Indicators

After applying power to the module, the LED indicators (*see page 28*) on the module illuminate as follows:

- The LED **LNK** of the RJ45 Ethernet port lights green when the physical link is established at the speed of 100 Mbps.
- The LED **ACT** of the RJ45 Ethernet port lights green when the signal is received at the module's port.
- Each optical port LED indicator (**FX1ACT** and **FX2ACT**) lights when a signal is received at the optical Rx port.

If a port indicator is off, it can indicate a lack of transmitted signal from another network node. Before replacing the BMXNRP020• fiber converters, check the cable connections for a possible incorrect or loose connection. Also check the indicators on other devices on the signal path to see if the signal loss is external to the module. For details, refer to the chapter Troubleshooting (*see page 51*).

Module Configuration

Module Configuration

When the BMXNRP020• fiber converters are integrated in an I/O station (local or remote), you can match the physical layout of the backplane with Control Expert configuration.

If one or more power supply modules is configured, the Control Expert software displays the power budget (*see Modicon M340, Processors, Setup Manual*) of all configured modules.

NOTE: The BMXNRP020• fiber converters do not require parameter configuration.

Chapter 4

Maintenance

Overview

This chapter provides troubleshooting and hot swapping information to maintain the BMXNRP020• fiber converters.

What Is in This Chapter?

This chapter contains the following topics:

Topic	Page
Hot Swapping	50
Troubleshooting	51

Hot Swapping

Overview

The BMXNRP020• fiber converters can be removed under power (hot swapped) without damaging modules or the backplane.

NOTE: You have to understand and plan for the consequences of hot-swapping a module.

Disconnecting a module will interrupt communication to the connected remote I/Os.

Be sure that you know which Ethernet remote I/Os are connected to the fiber converter, and the impact that this disconnection would have on your machine or process before attempting a hot-swap operation.

WARNING

HOT SWAPPING RESTRICTION

Do not hot swap modules in a Class 1, Division 2 environment.

Failure to follow these instructions can result in death, serious injury, or equipment damage.

Hot Swapping Procedure

The following table describes how to hot-swap a BMXNRP020• fiber converter:

Step	Action
1	Disconnect the copper cable(s).
2	Disconnect the fiber optic cable(s). NOTE: Install the protective covers on the connectors of the fiber optic cable(s) and on the port(s) of the BMXNRP020• fiber converter.
3	Remove the BMXNRP020• fiber converter from the backplane.
4	Install the new BMXNRP020• fiber converter to the free slot of the backplane.
5	Connect all the network cables to the new module.

Troubleshooting

Overview

As a general method, start investigations by checking the EIO head module transmission propagation through the whole path until reception at each drop. In a second step, connect and check each drop module transmission back to the EIO head. Refer to the chapter *System Diagnostics* (see *Quantum EIO, System Planning Guide*), for more details.

There are documented procedures for analyzing the wire side characteristics of EIO network applications, and it is recommended that they be used as a first line of attack and afterward whenever trouble is suspected.

The troubleshooting tables in this section cover the most likely encountered events with the BMXNRP020• fiber converters.

Detecting Broken Cables

Unlike copper cable, fiber cable contains physically separated transmit and receive lines.

Your system can lose communication through the receive line, while the transmit line remains physically intact, as shown in the following graphic:

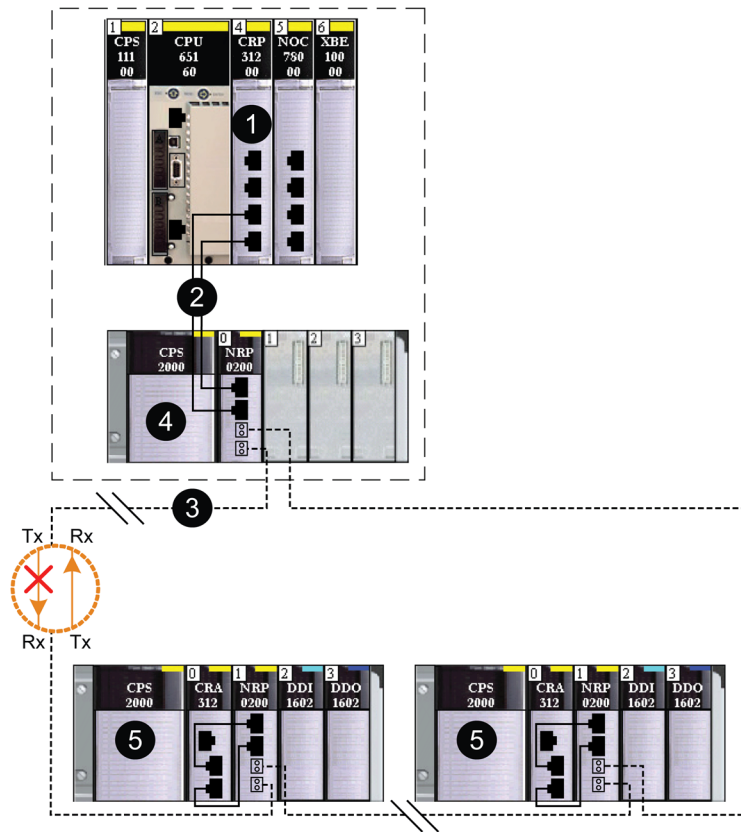

- 1 Quantum EIO local rack, containing a 140CRP31200 remote I/O head module
- 2 copper cables connecting the converter module
- 3 fiber cables connecting the BMXNRP0200 module to another BMXNRP0200 module on X80 Ethernet remote I/O drop
- 4 BMXNRP0200 module on X80 local extended rack
- 5 X80 Ethernet remote I/O drops containing BMXNRP0200 modules

In this scenario, the break in the transmit line causes both the RJ45 and the fiber ports on the BMXNRP0200 module to become inactive, with the result that the PLC does not receive input data from or drive output data to the remote I/O.

Diagnosing Broken Cables

The BMXNRP020• modules do not support RSTP. You cannot program a bit in the PLC to diagnose detected errors.

In the event of a BMXNRP020• module communication loss, the BMX CRA, 140 CRA, or 140 CRP module connected to the BMXNRP020• module reports the detected error. The BMXNRP020• modules allow a link-down indication that is sent through the Quantum EIO network in order for the 140CRP31200 remote I/O head module to re-establish a network communication path within 50 ms.

For detailed troubleshooting on the BMXNRP020• module, refer to the Troubleshooting (*see page 51*).

Troubleshooting Table

Identify the status of the LED indicators on the BMXNRP020• fiber converter as described in the left column and then take the corresponding corrective action(s) described in the right column:

LED Status	Diagnostic	Action
All LEDs are OFF	The fiber converter is not powered	Check the power supply module.
All LEDs are OFF while other modules installed on the backplane show normal behavior	An internal loss of power occurred in the fiber converter	Change fiber converter module.
ETH1 LEDs OFF, STS1 LED flickers (while ERR LED is OFF)	Fiber link of channel 1 is down	<ul style="list-style-type: none"> ● Check whether the fiber cable of channel 1 is connected to the partner ¹ correctly, and that the partner ¹ works well. ● Check the fiber cable.
ETH2 LED OFF, STS2 LED flicker (while ERR LED is OFF)	Fiber of channel 2 link down	Check whether the fiber cable of channel 2 is connected to the partner ¹ correctly, and the partner ¹ works well.
ETH1 LED OFF, STS1 LED ON (while ERR LED is OFF)	Copper of channel 1 link down	Check whether the copper cable of channel 1 is connected to the partner ¹ correctly, and the partner ¹ works well.
ETH2 LED OFF, STS2 LED ON (while ERR LED is OFF)	Copper of channel 2 link down	Check whether the copper cable of channel 2 is connected to the partner ¹ correctly, and the partner ¹ works well.
¹ NRP module connects to other Ethernet modules which has a fiber optic interface. For example., the DRS.		

LED Status	Diagnostic	Action
ERR LED is ON (STS1 or STS2 LED flickers)	SFP alarm or fiber PHY broken	<p>Plug out the transceiver first.</p> <p>If ERR LED turned OFF (that is, there is an alarm reported by the SFP), the possible errors are as follows:</p> <ul style="list-style-type: none"> ● If it is temperature alarm, try again by plugging in SFP after it cools down) ● Check if a third party SFP is used ● Check for transceiver mismatch with NRP, use multimode SFP with BMXNRP0201 or use single-mode SFP with BMXNRP0200 ● If transceiver is broken, correct information cannot be read from its memory <p>If ERR LED turned ON, the possible errors are as follows:</p> <ul style="list-style-type: none"> ● The internal communication (MII) of NRP is wrong ● The PHY connected to fiber is destroyed. Power down and power up the NRP to have a try
ERR LED is ON (STS1 or STS2 ON)	Copper PHY broken	<p>The possible errors are as follows:</p> <ul style="list-style-type: none"> ● The internal communication (MII) of NRP is wrong ● The PHY connected to fiber is destroyed. Power down and power up the NRP to have a try
ERR LED is ON, after powered up every time (without transceiver plugged in)	Fiber converter is broken	Change fiber converter module.
¹ NRP module connects to other Ethernet modules which has a fiber optic interface. For example., the DRS.		

Glossary



A

adapter

The target of real-time I/O data connection requests from scanners. It cannot send or receive real-time I/O data unless it is configured to do so by a scanner, and it does not store or originate the data communications parameters necessary to establish the connection. An adapter accepts explicit message requests (connected and unconnected) from other devices.

architecture

A framework for the specification of a network, constructed on the following:

- physical components and their functional organization and configuration
- operational principles and procedures
- data formats used in its operation

attenuation

Signal loss through an electrical circuit or conductor (*see also* **signal loss**).

B

bandwidth

A range of frequencies.

bend radius

The radius of the arc along which a cable can be bent.

bus

A single cable connecting multiple ports.

C

connection

A virtual circuit between 2 or more network devices, created prior to the transmission of data. After a connection is established, a series of data is transmitted over the same communication path, without the need to include routing information — including source and destination address — with each piece of data.

D

drop

An address on the RIO network. *See also* **node**.

F

fiber

A thin filament of glass. An optical waveguide consisting of a core and a cladding is capable of carrying information in the form of light.

full duplex

The ability of 2 networked devices to independently and simultaneously communicate with each other in both directions.

G

graded-index

Fiber design in which the refractive index of the core is lower towards the outside of the fiber core and increases towards the center of the core. It bends the rays inward and allows them to travel faster in the lower index-of-refraction region. This type of fiber provides high bandwidth capabilities.

H

high capacity daisy chain loop

Often referred to as HCDCL, a high-capacity daisy chain loop uses DRSs to extend the distance between remote I/O drops or connect sub-rings (containing remote I/O drops or distributed I/O devices) and/or distributed I/O clouds to the Ethernet remote I/O network.

hot standby

A high availability Quantum control system with a second (standby) PLC that maintains up to date system status. If the primary PLC becomes inoperable, the standby PLC takes control of the system.

I

impedance

See **characteristic impedance**.

L

local rack

A Quantum rack containing the controller, a power supply, and an Ethernet remote I/O head module. A local rack consists of 1 or 2 racks — the main rack (containing the remote I/O head module) and an optional extended rack. A Quantum Ethernet remote I/O network requires 1 local rack on the main ring.

M**MII**

Media Independent Interface. The MII is used to connect Ethernet to PHY.

N**network**

A system consisting of the cable media components and the communication nodes.

node

An intelligent unit or option on the RIO network, either a RIO processor or a drop adapter.

P**PHY**

Physical layer transceiver for Ethernet.

PLC

programmable logic controller. The PLC is the brain of an industrial manufacturing process. It automates a process as opposed to relay control systems. PLCs are computers suited to survive the harsh conditions of the industrial environment.

R**remote I/O drop**

One of the 3 types of remote I/O devices in an Ethernet remote I/O network. A remote I/O drop is a Quantum rack of I/O modules that are connected to an Ethernet remote I/O network and managed by an Ethernet remote adapter module. A drop can be a single rack or a rack with an extension rack.

remote I/O network

An Ethernet-based network that contains 1 standalone PLC or one Hot Standby system and remote I/O devices. There are 3 types of remote I/O devices: a local rack, a remote I/O drop, and a ConneXium extended dual-ring switch (DRS). Distributed I/O devices may also participate in a remote I/O network via connection to DRSs.

RSTP

(rapid spanning tree protocol) A protocol that allows a network design to include spare (redundant) links to provide automatic backup paths if an active link stops working, without the need for loops or manual enabling/disabling of backup links.

S

SFP

small form-factor pluggable. The SFP is a transceiver that acts as an interface between module and fiber optic cables.

signal loss

The amount of signal lost through media devices. *See also* **attenuation**.

simple daisy chain loop

A simple daisy chain loop contains remote I/O devices only (no switches or distributed I/O devices). This topology consists of a local rack (containing a remote I/O head module) and 1 or more remote I/O drops (each drop containing a remote I/O adapter module).

T

topology

The complete media specification. The topology should be mapped into a log with all installation details for future reference.

twisted pair cable

A type of transmission line having a cable consists of a pair of insulated wires twisted together for the purpose of cancelling out electromagnetic interference (EMI) from external sources.

W

wavelength

The distance between the same point on adjacent waves.



A

- Architectures
 - introduction, *14*
 - Quantum Ethernet I/O network topologies, *17*
- attenuation
 - bandwidth, *34*
 - parameters, *34*

B

- BMXNRP0200
 - configuration, *48*
 - general specifications, *29*
 - installation, *36*
 - LED indicators, *28*
 - mechanical and electrical specifications, *31*
 - Presentation, *24*
- BMXNRP0200C
 - configuration, *48*
 - general specifications, *29*
 - installation, *36*
 - LED indicators, *28*
 - mechanical and electrical specifications, *31*
 - Presentation, *24*
- BMXNRP0201
 - configuration, *48*
 - general specifications, *29*
 - installation, *36*
 - LED indicators, *28*
 - mechanical and electrical specifications, *31*
 - Presentation, *24*
- BMXNRP0201C
 - configuration, *48*
 - general specifications, *29*
 - installation, *36*
 - LED indicators, *28*
 - mechanical and electrical specifications,

- 31*
- Presentation, *24*

C

- certifications, *32*

F

- fiber optic cable
 - installation, *39*

G

- grounding, *35*

H

- hot swapping, *50*

I

- installation
 - fiber optic cable, *39*

S

- standards, *32*

T

- troubleshooting, *51*

