



Main

| | |
|---------------------------|--|
| Range of product | Modicon M340 automation platform |
| Product or component type | Counter module |
| Number of channels | 2 |
| Counting frequency | <= 60000 Hz |
| Number of inputs | 6 |
| Input compatibility | Incremental encoder with push-pull outputs 10...30 V totem pole 2-wire/3-wire proximity sensor 19.2...30 V |
| Input voltage | 24 V DC type 3 |
| Number of outputs | 2 |
| Output voltage | 24 V DC |

Complementary

| | |
|---------------------------------|--|
| Counter functions | 32-bit counter counting Count events Down counting Frequency meter Loop (modulo) counting Measure time periods Ratio count Width modulation |
| Cycle time | 1 ms |
| Isolation voltage | 1500 V for 60 s |
| Input type | 3 auxiliary input 3 high speed |
| Input voltage limits | 30 V |
| Input current | > 2 mA at 11 V |
| Voltage state 1 guaranteed | 11...30 V |
| Current state 1 guaranteed | >= 6 mA |
| Voltage state 0 guaranteed | < 5 V |
| Current state 0 guaranteed | <= 1.5 mA |
| Discrete output logic | Positive or negative configurable |
| Maximum output current | 2 A per module 0.5 A per output |
| Output voltage limits | 19.2...30 V |
| Maximum load current | 1 A per module 0.5 A per output |
| Leakage current | <= 0.1 mA at state 0 |
| Voltage drop | < 3 V at state 1 |
| Output overload protection | Integrated |
| Output short-circuit protection | 1.5 A integrated |
| Overlap time | 0.2 ms |
| Electrical connection | 1 connector 10 pins for wiring auxiliary input and sensor power supply 1 connector 16 pins for wiring the sensors of counter 0 1 connector 16 pins for wiring the sensors of counter 1 |
| Current consumption | 200 mA 3.3 V DC bus 40 mA 24 V DC rack 80 mA 24 V DC sensor |
| Module format | Standard |
| Product weight | 0.112 kg |

The information provided in this documentation contains general descriptions and/or technical characteristics of the performance of the products contained herein. This documentation is not intended as a substitute for and is not to be used for determining suitability or reliability of these products for specific user applications. It is the duty of any such user or integrator to perform the appropriate and complete risk analysis, evaluation and testing of the products with respect to the relevant specific application or use thereof. Neither Schneider Electric Industries SAS nor any of its affiliates or subsidiaries shall be responsible or liable for misuse of the information contained herein.

Environment

| | |
|---------------------------------------|--------------------------------|
| ambient air temperature for operation | 0...60 °C |
| relative humidity | 10...95 % without condensation |
| IP degree of protection | IP20 |
| protective treatment | TC |

Offer Sustainability

| | |
|----------------------------------|---|
| Sustainable offer status | Green Premium product |
| RoHS (date code: YYWW) | Compliant - since 0722 - Schneider Electric declaration of conformity |
| REACH | Reference not containing SVHC above the threshold |
| Product environmental profile | Available |
| Product end of life instructions | Available |

Modules Mounted on Racks

Dimensions

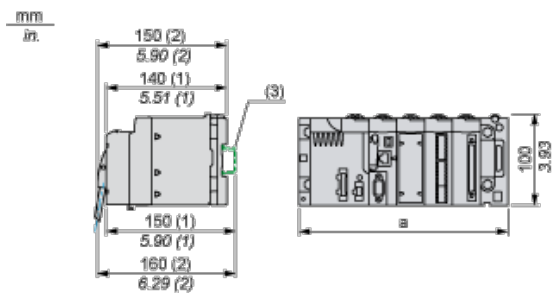

- (1) With removable terminal block (cage, screw or spring).
- (2) With FCN connector.
- (3) On AM1 ED rail: 35 mm wide, 15 mm deep. Only possible with BMXXBP0400/0400H/0600/0600H/0800/0800H rack.

| Rack references | a in mm | a in in. |
|----------------------------|---------|----------|
| BMXXBP0400 and BMXXBP0400H | 242.4 | 09.54 |
| BMXXBP0600 and BMXXBP0600H | 307.6 | 12.11 |
| BMXXBP0800 and BMXXBP0800H | 372.8 | 14.68 |
| BMXXBP1200 and BMXXBP1200H | 503.2 | 19.81 |

Counting Module Wiring

Note

The two 16-pin connectors and the 10-pin connector are sold separately and are available in the BMXXTSHSC20 connection kit.

Assignment of the 16-Pin Connector

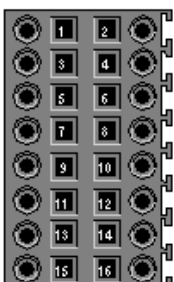

| Pin number | Symbol | Description |
|--------------|---------|----------------------------------|
| 1, 2, 7, 8 | 24V_SEN | 24 VDC output for sensors supply |
| 5, 6, 13, 14 | GND_SEN | 24 VDC output for sensors supply |

| | | |
|--------|---------|-----------------------|
| 15, 16 | FE | Functional earth |
| 3 | IN_A | Input A |
| 4 | IN_SYNC | Synchronization input |
| 9 | IN_B | Input B |
| 10 | IN_EN | Enable input selected |
| 11 | IN_REF | Homing input |
| 12 | IN_CAP | Capture input |

Sensors Connection Example

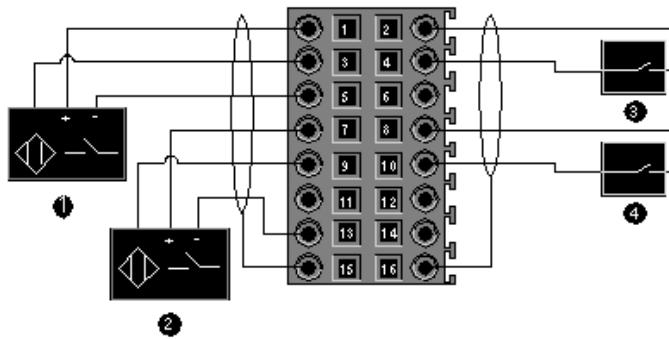

- 1 IN_A input
- 2 IN_B input
- 3 IN_SYNC input (synchronization input)
- 4 IN_EN input (enable input)

Encoder Connection Example for Axis Control

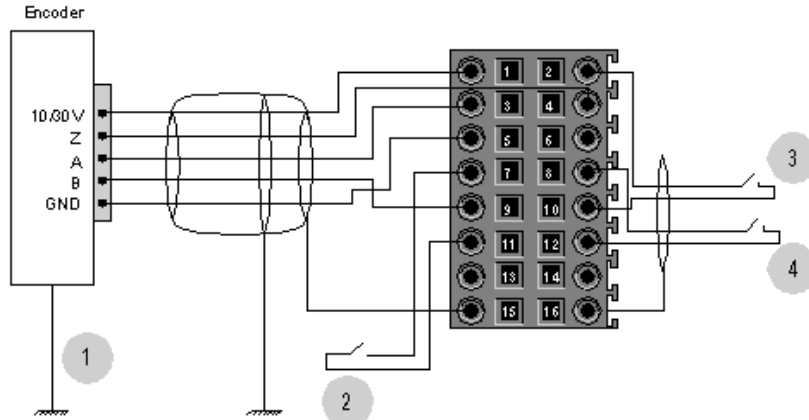

- 1 Encoder (inputs A, B and Z)
- 2 IN_REF input (homing input)
- 3 IN_EN input (enable input)
- 4 IN_CAP input (capture input)

Assignment of the 10-Pin Connector

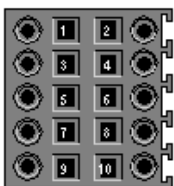

| Pin number | Symbol | Description |
|------------|--------|---------------------------------|
| 1 | 24V_IN | 24 VDC input for sensors supply |

| | | |
|----|---------|--|
| 2 | GND_IN | Return 24 VDC input for sensors supply |
| 5 | Q0-1 | Q1 output for counting channel 0 |
| 6 | Q0-0 | Q0 output for counting channel 0 |
| 7 | Q1-1 | Q1 output for counting channel 1 |
| 8 | Q1-0 | Q0 output for counting channel 1 |
| 9 | 24V_OUT | 24 VDC input for actuators supply |
| 10 | GND_OUT | Return 24 VDC input for actuators supply |

Connecting Outputs and Supplies

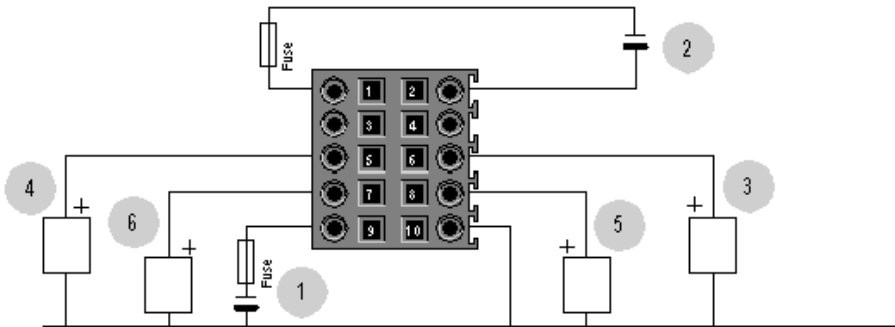

- 1 24 VDC supply for sensors
- 2 Return 24 VDC supply for sensors
- 3 Actuator for the Q0 output of counting channel 0
- 4 Actuator for the Q1 output of counting channel 0
- 5 Actuator for the Q0 output of counting channel 1
- 6 Actuator for the Q1 output of counting channel 1

The Q0 and Q1 outputs are limited by a maximum current of 0.5 A.

Recommended Circuit for high-Noise Environment Using BMXXSP*** Electromagnetic Protection Kit

