

BMXDDM3202K

discrete I/O module M340 - 16 inputs - 24 V DC - 16 outputs - solid state



Main

Range of product	Modicon X80
Product or component type	Discrete I/O module
Discrete input number	16
Input type	Current sink (logic positive)
Discrete input voltage	24 V DC positive
Discrete input current	2.5 mA
Input compatibility	With 2-wire/3-wire proximity sensors conforming to IEC 60947-5-2
Discrete output number	16
Discrete output type	Solid state
Discrete output voltage	24 V 19...30 V DC
Discrete output current	0.1 A

Complementary

Sensor power supply	19...30 V
Voltage state 1 guaranteed	≥ 11 V
Current state 1 guaranteed	≥ 2 mA
Voltage state 0 guaranteed	≤ 5 V
Current state 0 guaranteed	≤ 1.5 mA
Current per channel	0.125 A
Current per module	≤ 3.2 A
Leakage current	≤ 0.1 mA at state 0
[Ures] residual voltage	1.5 V at state 1
Input impedance	9600 Ohm
Insulation resistance	> 10 MOhm 500 V DC
Power dissipation in W	≤ 4 W
DC typical filtering time	4 ms
DC maximum filtering time	7 ms
Response time on output	1.2 ms
Paralleling of outputs	Yes : 3 maximum
Typical current consumption	69 mA at 24 V DC 150 mA at 3.3 V DC
Current consumption	≤ 104 mA at 24 V DC ≤ 166 mA at 3.3 V DC
MTBF reliability	432904 H
Protection type	Overvoltage protection on output Reverse polarity protection on input Reverse polarity protection on output 1 external fuse per group of input channel 0.5 A fast blow
Output overload protection	With electronic circuit breaker 0.125 A $< I_d < 0.185$ A With current limiter
Output overvoltage protection	With transil diode
Output short-circuit protection	With 2 A external fuse
Reverse polarity protection	Reverse mounted diode
Voltage detection threshold	< 14 V DC preactuator fault < 14 V DC sensor fault > 18 V DC preactuator OK > 18 V DC sensor OK

The information provided in this documentation contains general descriptions and/or technical characteristics of the performance of the products contained herein. This documentation is not intended as a substitute for and is not to be used for determining suitability or reliability of these products for specific user applications. It is the duty of any such user or integrator to perform the appropriate and complete risk analysis, evaluation and testing of the products with respect to the relevant specific application or use thereof. Neither Schneider Electric Industries SAS nor any of its affiliates or subsidiaries shall be responsible or liable for misuse of the information contained herein.

Tungsten load	<= 1.2 W
Switching frequency	0.5/LI² Hz
Overload time	<= 15 ms
Load impedance ohmic	<= 220 Ohm
Status LED	1 LED red for module error (ERR) 1 LED green for module operating (RUN) 1 LED per channel green for channel diagnostic 1 LED red for module I/O
Product weight	0.11 kg

Environment

IP degree of protection	IP20
product certifications	CE CSA UL RCM Merchant Navy EAC
standards	EN/IEC 61131-2 EN/IEC 61010-2-201 UL 61010-2-201 CSA C22.2 No 61010-2-201
dielectric strength	1500 V AC at 50/60 Hz 1 minute, output/ground 1500 V AC at 50/60 Hz 1 minute, output/internal logic 1500 V AC at 50/60 Hz 1 minute, primary/secondary 500 V DC 1 minute, between group of inputs and outputs
vibration resistance	3 gn
shock resistance	30 gn
ambient air temperature for storage	-40...85 °C
ambient air temperature for operation	0...60 °C
relative humidity	5...95 % without condensation 55 °C
protective treatment	TC
operating altitude	0...2000 m 2000...5000 m (with derating factor)

Offer Sustainability

Sustainable offer status	Green Premium product
RoHS (date code: YYWW)	Compliant - since 0722 - Schneider Electric declaration of conformity
REACH	Reference not containing SVHC above the threshold
Product environmental profile	Available
Product end of life instructions	Available

Modules Mounted on Racks

Dimensions

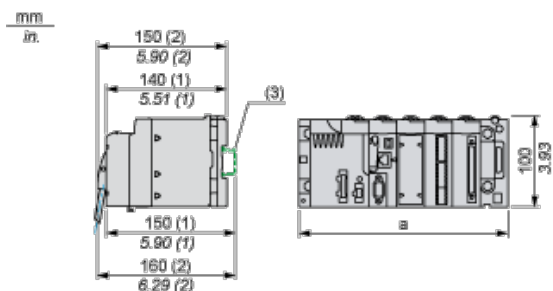

- (1) With removable terminal block (cage, screw or spring).
- (2) With FCN connector.
- (3) On AM1 ED rail: 35 mm wide, 15 mm deep. Only possible with BMXXBP0400/0400H/0600/0600H/0800/0800H rack.

Rack references	a in mm	a in in.

BMXXBP0400 and BMXXBP0400H	242.4	09.54
BMXXBP0600 and BMXXBP0600H	307.6	12.11
BMXXBP0800 and BMXXBP0800H	372.8	14.68
BMXXBP1200 and BMXXBP1200H	503.2	19.81

Connecting the Module

Input Circuit Diagram

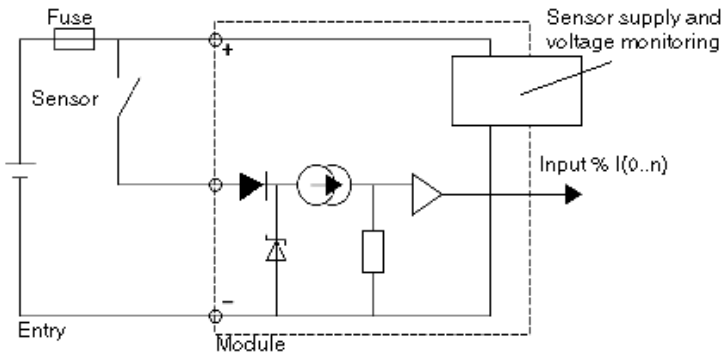

Output Circuit Diagram

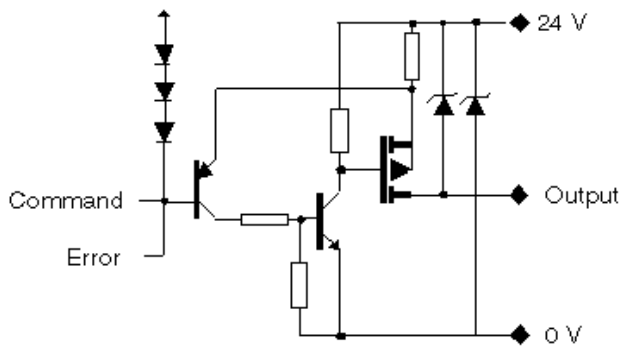

Module Connection

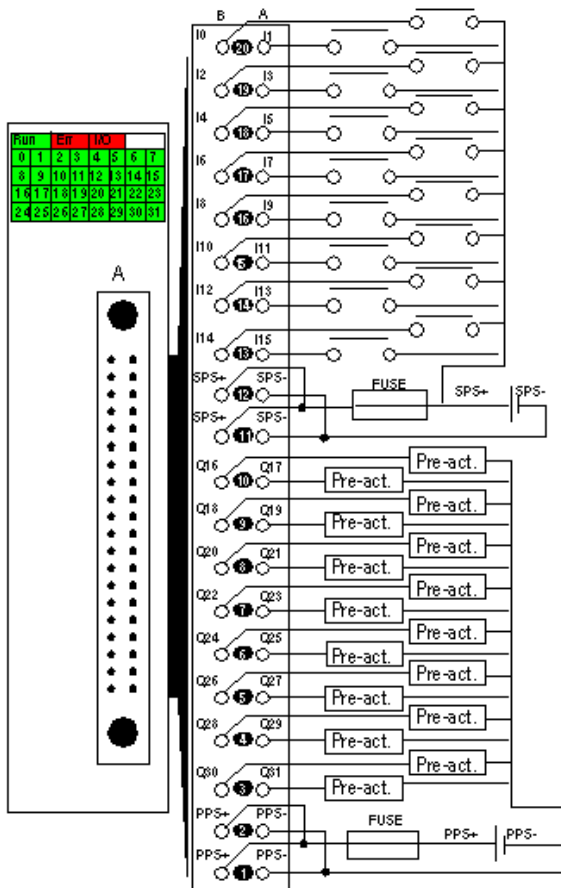

power24 VDC
supply

inputfast blow fuse of 0.5 A
fuse

outputfast blow fuse of 2 A
fuse

pre- pre-actuator
act

SPS sensor power supply

PPS pre-actuator power supply