



### Main

Range of product	Harmony XVU
Product or component type	Modular tower light
Accessory / separate part type	Fixing plate
Accessory / separate part category	Mounting and fixing accessory
Component name	XVU
Mounting diameter	60 mm

### Complementary

Mounting support	Wall mounted
Product compatibility	XVUZ02 XVUZ02Q XVUZ03 XVUZ400 XVUZ800 XVUZ05
Material	Aluminium V-0 flame retardant conforming to UL 94
Housing colour	Black
[Us] rated supply voltage	110...240 V AC 24 V AC/DC
Length	8 mm
Product weight	0.36 kg

### Environment

ambient air temperature for storage	-40...70 °C
ambient air temperature for operation	-25...50 °C
IP degree of protection	IP65
product certifications	CE CSA UL

### Offer Sustainability

Sustainable offer status	Green Premium product
RoHS (date code: YYWW)	Compliant - since 1529 - Schneider Electric declaration of conformity
REACH	Reference not containing SVHC above the threshold
Product environmental profile	Available
Product end of life instructions	Available

### Dimensions

#### Rear View

mm  
in.

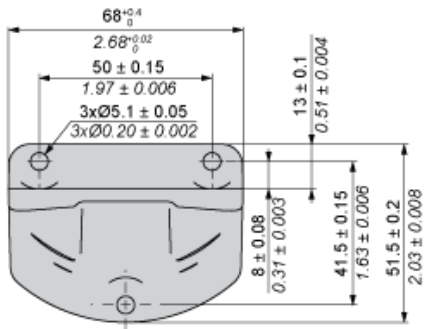

### Side View

mm  
in.

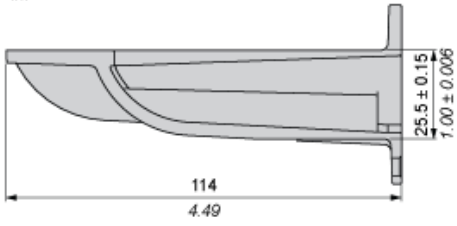

### Vertical Support Panel Drillings

mm  
in.

