

XPSMCMCP0802

Controller with 8 inputs 2 outputs monitors expansion modules with screw term



Main

Range of product	Preventa Safety automation
Product or component type	Safety controller CPU
Device short name	XPSMCM
Electrical connection	Screw terminal
[Us] rated supply voltage	24 V (- 20...20 %) DC
Number of inputs	8 digital for input connection 2 digital for interlock start/restart or external device monitoring
Number of outputs	2 safety outputs OSSD for contactor/drive connection 4 test for line control outputs 2 configurable for diagnostic connection
Discrete input voltage	24 V
Discrete output current	400 mA
Discrete input current	400 mA
Discrete input type	Safety input PNP
Discrete output type	PNP
Function of module	Emergency stop conforming to EN/ISO 13850 Guard monitoring conforming to EN/ISO 14119 Enabling switch monitoring conforming to EN/IEC 60947-5-1 Light curtain monitoring conforming to EN/IEC 61496-1 Foot switch monitoring conforming to EN/IEC 60947-5-1 Magnetic switch monitoring conforming to EN/ISO 14119 Two-hand control conforming to EN 574 Safety mat monitoring conforming to EN/ISO 14119 Enabling switch monitoring conforming to EN 61326-1 Muting function of light curtains conforming to EN/IEC 60947-5-1 Counter functions conforming to EN/IEC 61800-5-2 Speed monitoring conforming to EN/IEC 61800-5-2

Complementary

Synchronisation time between inputs	< 0.5 ms
Power dissipation in W	3 W
Number of I/O expansion module	14, expandable up to 128 input 14, expandable up to 16 output
Integrated connection type	USB 2.0 port Backplane expansion bus
Data storage equipment	SD card (optional)
Inductive load	30 mH
Load capacitance	0.82 µF
Safety level	SILCL 3 conforming to IEC 62061 Can reach category 4 conforming to EN/ISO 13849-1 Can reach PL = e conforming to EN/ISO 13849-1 Type 4 conforming to EN/IEC 61496-1
Quality labels	CE

The information provided in this documentation contains general descriptions and/or technical characteristics of the products contained herein. This documentation is not intended as a substitute for and is not to be used for determining suitability or reliability of these products for specific user applications. It is the duty of any such user or integrator to perform the appropriate and complete risk analysis, evaluation and testing of the products with respect to the relevant specific application or use thereof. Neither Schneider Electric Industries SAS nor any of its affiliates or subsidiaries shall be responsible or liable for misuse of the information contained herein.

Local signalling	1 LED green with PWR marking for power ON 1 LED green with RUN marking for RUN (status) 1 LED red with E IN marking for internal error 1 LED red with E EX marking for external error 1 LED orange with COM marking for communication 1 LED blue with EN marking for master enable 8 LEDs yellow with IN marking for input status 2 LEDs green/red with OUT marking for output status 2 LEDs yellow with RST marking for restart signal 2 LEDs yellow with STATUS marking for output channel
Connections - terminals	2-wire captive screw terminals, removable terminal block 1-wire captive screw terminals, removable terminal block
Cable cross section	(0.2...1.5 mm ² - AWG 24...AWG 16) flexible cable without cable end (0.2...2.5 mm ² - AWG 24...AWG 14) flexible cable without cable end (0.25...1 mm ² - AWG 23...AWG 18) flexible cable with cable end, without bezel (0.25...2.5 mm ² - AWG 23...AWG 14) flexible cable with cable end, with bezel (0.25...1.5 mm ² - AWG 23...AWG 16) flexible cable with cable end, without bezel (0.5...1.5 mm ² - AWG 20...AWG 16) flexible cable with cable end, with double bezel (0.2...1 mm ² - AWG 24...AWG 18) solid cable without cable end (0.2...2.5 mm ² - AWG 24...AWG 14) solid cable without cable end
Mounting support	Omega 35 mm DIN rail conforming to EN 50022
Depth	114.5 mm
Height	99 mm
Width	22.5 mm
Product weight	0.25 kg

Environment

standards	EN/IEC 61496-1 EN/IEC 61508 EN/IEC 61800-5-1 EN/ISO 13849-1 IEC 62061
product certifications	CULus TÜV RCM
IP degree of protection	IP20
ambient air temperature for operation	-10...55 °C
ambient air temperature for storage	-20...85 °C
relative humidity	10...95 %
pollution degree	2
[Uimp] rated impulse withstand voltage	4 kV conforming to EN/IEC 61800-5-1
safety reliability data	PFHd = 6.06E-9 1/h DC > 99 % MTTFd < 100 years at high
insulation	250 V AC between power supply and housing conforming to EN/IEC 61800-5-1
overvoltage category	II
electromagnetic compatibility	Electrostatic discharge immunity test - test level 6 kV, on contact conforming to EN/IEC 61000-4-2 Electrostatic discharge immunity test - test level 20 kV, on air conforming to EN/IEC 61000-4-2 Susceptibility to electromagnetic fields - test level 10 V/m, 80...1000 MHz conforming to EN/IEC 61000-4-3 Susceptibility to electromagnetic fields - test level 30 V/m, 1.4 GHz...2 GHz conforming to EN/IEC 61000-4-3
vibration resistance	+/-0.35 mm (f = 10...55 Hz) conforming to EN/IEC 61496-1
shock resistance	10 gn (duration = 16 ms) shocks : 1000 shocks on each axis conforming to EN/IEC 61496-1
service life	20 yr

Offer Sustainability

Sustainable offer status	Green Premium product
RoHS (date code: YYWW)	Compliant - since 1450 - Schneider Electric declaration of conformity
REACH	Reference not containing SVHC above the threshold
Product environmental profile	Available

Dimensions

Screw Terminal

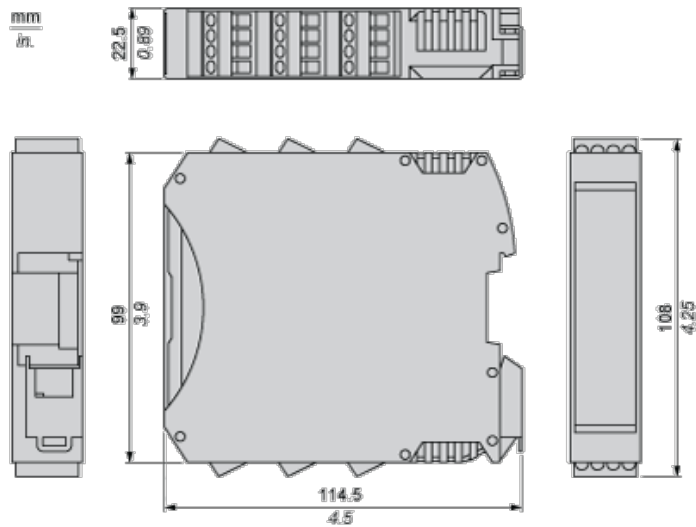

Mounting Safety Controller CPU with Module(s)

Mount BackPlane Connector on Rail

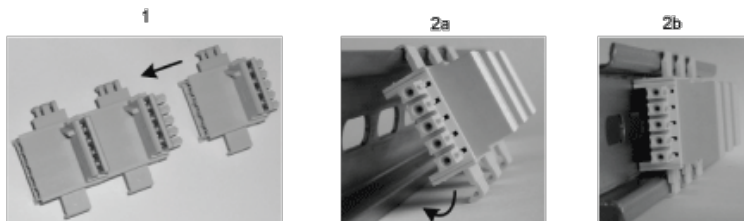

- 1 : Connect as much Backplane Connector as module to be install.
- 2 : Fix the connectors to the rail (Top first).

Mount Safety Controller CPU with Other Module(s)

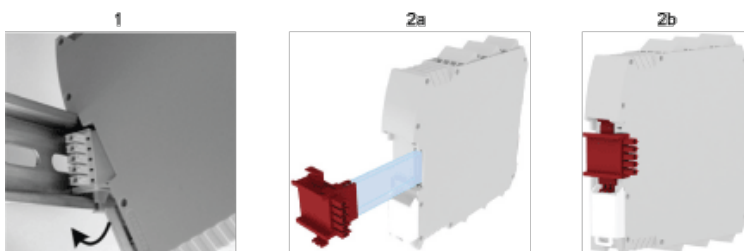

- 1 : Mount controller CPU and modules on rail.
- 2 : Make sure that the controller CPU or the module(s) are plugged on the BackPlane connector.

Wiring

Terminal Designation

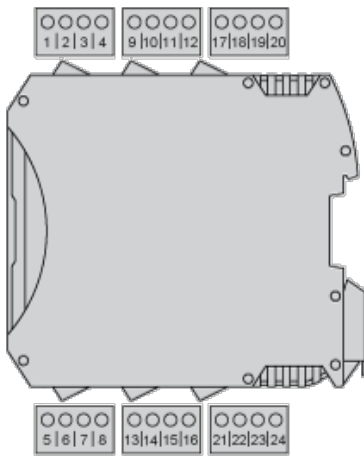

Terminal	Signal	Description
1	24 VDC	24 Vdc power supply
2	MASTER_ENABLE1	Master enable 1
3	MASTER_ENABLE2	Master enable 2
4	0 VDC	0 Vdc power supply
5	OSSD1_A	Static output 1
6	OSSD1_B	
7	RESTART1	Feedback/Restart 1
8	OUT_STATUS 1	Programmable digital output
9	OSSD2_A	Static output 2
10	OSSD2_B	
11	RESTART2	Feedback/Restart 2
12	OUT_STATUS 2	Programmable digital output
13	OUT_TEST1	Short circuit detected output
14	OUT_TEST2	
15	OUT_TEST3	
16	OUT_TEST4	
17	INPUT1	Digital input 1
18	INPUT2	Digital input 2
19	INPUT3	Digital input 3
20	INPUT4	Digital input 4
21	INPUT5	Digital input 5
22	INPUT6	Digital input 6
23	INPUT7	Digital input 7
24	INPUT8	Digital input 8

Wiring Example

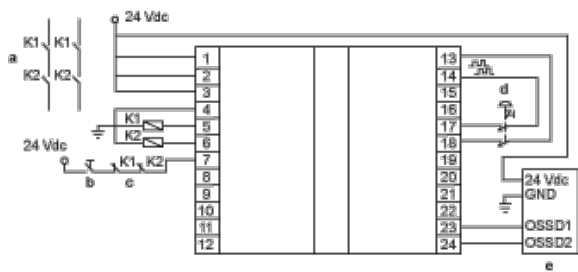

- a : Contactors
- b : Restart
- c : Feedback
- d : Emergency stop
- e : Light curtain