

UP TO
93%
ENERGY SAVINGS

Microwave sensor luminaire designed for Car Parks and Fire Stairs

Chamaeleon™ Eco

Microwave sensor controlled luminaire



Optional
IR commissioning tool



PRODUCT RANGE

Model #	Description	Lumens (lm) Full light	Rated Power (W)	
			Full light (adjustable)	Standby (adjustable)
EN-SL-S	Ceiling mount standard	2500	22	3
EN-SL-E	Ceiling mount emergency	2500	25	6

EnLighten has broadened the award winning Chamaeleon™ range with the Chamaeleon™ Eco. It is an excellent choice for fire stairs, car parks and corridors, featuring design enhancements that allow for easier installation and light control flexibility.

The Eco complements the Chamaeleon™ range to offer a valuable solution for back of house lighting in residential strata common areas, commercial and industrial applications.

CONTRACTOR BENEFITS

- **Emergency and non emergency** options available
- **Ease of installation** - Up to 50% faster to install with predrilled holes, screw less gear tray and large terminal block
- **Commissioning tool** - Easily adjustable with infrared, universal remote to tailor the output and options to suit the client's requirements
- **Daylight Harvesting** - Additional savings are available by activating the PE sensor
- **IP65** - Ingress protection
- **IK10** - Highest level of impact resistance

CLIENT BENEFITS

- **Reduce energy cost** through utilising the full features of the light
- **Expected life >54,000hrs** from the selection of high quality LEDs
- **Adjustable full and standby lighting levels** - Can also be set to Permanently On
- **Australian design**
- **5 year warranty**



APPLICATIONS



FEATURES

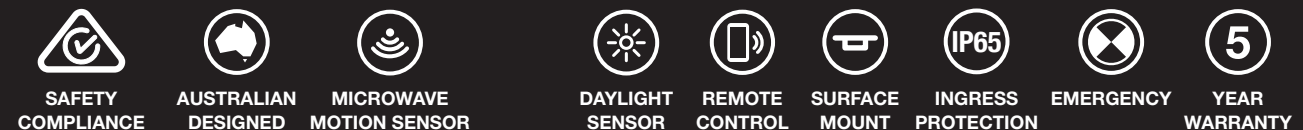

DIMENSIONS AND WEIGHT

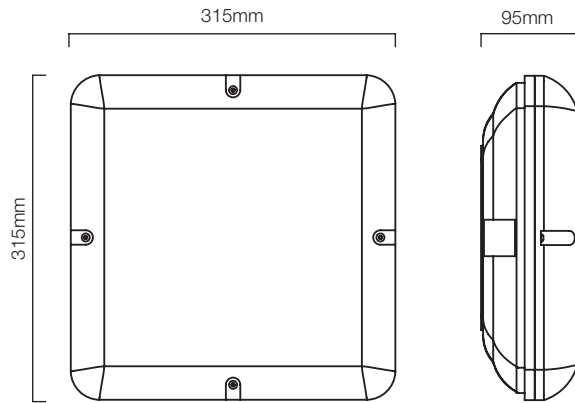

Weight: 2.5kg (standard)
3kg (emergency)

PHOTOMETRICS

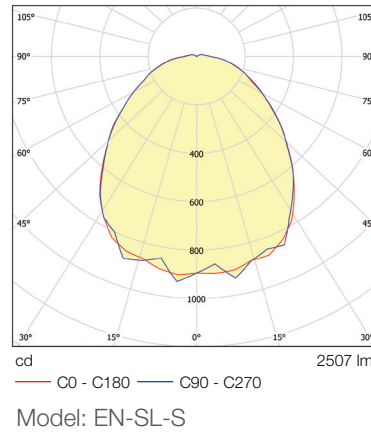

TECHNICAL INFORMATION

Optical

Light source	Lumileds LED
Lumen output	2500 lm
CRI	Ra>80
CCT	4000K

Electrical

Power consumption (W)	22W Full light output (standard) & 25W (emergency) 3W Standby light output (standard) & 6W (emergency)
Operating frequency	50/60Hz
Operating voltage range	100- 240 V AC
Power factor	>0.9 240 V AC at full load

Emergency light

Battery type	7.2V NiMH 1800mAh
Discharge time	90 minutes
Emergency classification	D50

Environmental

IP rating	IP65
Impact rating	IK10
Weight	2.5kg (standard) 3kg (emergency)
Ambient temperature range	-10° C to + 50° C
Material Composition (body)	Polycarbonate
Material Composition (diffuser)	Polycarbonate
Expected Lifespan	>54,000 hours @ L70

Controls

Microwave motion sensor & PE daylight sensor standard
Optional IR remote control

Warranty*

5 years (Battery 1 year)

Data subject to change without notice
* Refer to warranty policy

COMPLIANCE

The Chamaeleon Eco series meets or exceeds all relevant standards and regulatory requirements.



For a full compliance and testing list visit www.enlighten.com.au. IES files, warranty, installation and product guides are also available for download.

Sold nationally through major electrical wholesalers.