



# TWINSPOT PRO IP65

A NEW ERA OF EMERGENCY MONITORING AND TESTING



## FEATURES

- **IP65 Rating**
- Surface mounted
- Premium Lithium batteries (LiFePO4) and smart charger
- Fully compliant (AS/NZS 2293)
- Average power consumption <0.25W



### WIRELESS UPGRADE

Automatically test and sync data to the Cloud.



### DALI CERTIFIED:

Connect to a DALI system for DALI testing.



### SELF TEST:

Commission the product to perform its own tests.



### SINGLE POINT UNIT:

Out of the box Gen III works as a SPU.

**ORDERING INFORMATION**

CODE	DESCRIPTION	PRODUCT NUMBER	LED WATTAGE	CARTON QTY.	WEIGHT (NET/ GROSS)
01707	Twinspot Pro Black Emergency IP65 Luminaire	9336462017074	4.3 W	4	2.05 Kg / - Kg
01708	Twinspot Pro Emergency IP65 Luminaire (White)	9336462017081	4.3 W	4	2.05 Kg / - Kg

**OPERATIONAL INFORMATION**

GENERAL				BATTERY	
Voltage (V)	220-240V	Mounting Type	Surface mounted (wall and ceiling)	Battery Type	LiFePO4
Frequency (Hz)	50 Hz	Duration	1 / 2 / 3 / 4 / 8 Hours (dependant on jumpers)	Battery Voltage	6.4 V
Max. Ambient Temp.	40°C			Battery Code(s)	1303
Class	I			Charging Time	16 Hours
IP Rating	IP65			Charger Operation	Smart
Wiring	Hard wired				

**TOTAL POWER CONSUMPTION (TPC)**

MODEL	MAINTAINED		NON - MAINTAINED	
	Max.	Avg.	Max.	Avg.
Twinspot Pro Emergency IP65 Luminaire (01707, 01708)	< 7 W	4.25 W	3 W	0.25 W

**CONSTRUCTION AND DIMENSIONS**

BODY	PC
DIFFUSER	PC
GEAR TRAY	Galvanized steel

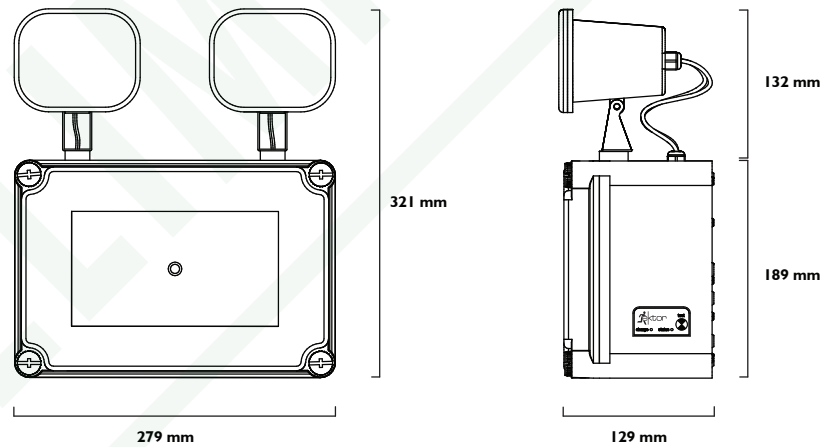
**TWINSPOOT EMERGENCY IP65**

**NOTE:** For more information on the chemical resistance of our polycarbonate, please see the technical downloads page at [ektor.com.au](http://ektor.com.au)

**ACCESSORIES AND SPARE PARTS**

CODE	DESCRIPTION
01303	Battery 3000mAh 6.4V, 2 Cell LiFePO4

For upcoming models, please contact your rep

Datasheet is subject to change without notice

Last updated: 19.February 2016\_V1.6



Please view our website for **full datasheet**