

System pro M compact® Miniature Circuit Breaker S 200 80A-100A

The miniature circuit breakers of the System pro M compact® series S 200 provide state-of-the-art safety and comfort. They stand out due to their high performance and the wide range of accessories and approvals.





The additional electrical currents 80 A and 100 A complement the current portfolio of the System pro M compact® and offer maximum performance in a single module width.



Features

- Clear contact position indication in red/green (“real CPI”)
- Unique, patented twin terminal with captive screws and an increased opening for cables up to max. 50 mm², finger-proof (IP20)
- Busbar slot in the back for best visibility during installation
- High performance in building installations and industrial applications up to 6 kA at U_g = 400 V AC acc. to IEC/EN 60947-2 and IEC/EN 60898-1
- Individual product identification code
- Approved acc. to IEC/EN 60898-1 and IEC/EN 60947-2 for global use

Country approvals

Approval mark	Description	Country
	VDE	Germany
	CCC	China
	IMQ	Italy
	EAC	Russia
	GOST Fire	
	RCM	Australia
	SABS	South Africa

Note:

Not all approvals are printed on the MCBs.

The indicated approvals generally cover all available approvals worldwide. To verify the approval status in your country please get in touch with your ABB contact person.

Miniature Circuit Breaker S 200 80A-100A

Technical data

S 200 80A-100A	
General Data	
Standards	IEC/EN 60898-1, IEC/EN 60947-2
Poles	1P, 2P, 3P, 4P, 1P+N, 3P+N
Tripping characteristics	B, C
Rated current I_n	80 A, 100 A
Rated frequency f	50/60 Hz
Rated insulation voltage U_i acc. to IEC/EN 60664-1 (VDE 0110-1)	440 V AC
Overvoltage category	III
Pollution degree	2
IEC/EN 60898-1 (VDE 0641-11)	
Rated operational voltage U_n	1P: 230/400 V AC; 1P+N: 230 V AC; 2P, 3P, 4P, 3P+N: 400 V AC
Max. power frequency recovery voltage U_{max}	1P: 253/440 V AC; 1P+N: 253 V AC; 2P, 3P, 4P, 3P+N: 440 V AC
Min. operating voltage	12 V AC
Rated short-circuit capacity I_{cn}	6 kA
Rated impulse withstand voltage U_{imp} (1.2/50 μ s)	4 kV (test voltage 6.2 kV at sea level, 5 kV at 2,000 m)
Dielectrical test voltage	2 kV (50/60 Hz, 1 min.)
Reference temperature for tripping characteristics	B, C: 30 °C
Electrical endurance	10,000 ops. (AC); one cycle 2 s - ON, 28 s - OFF
IEC/EN 60947-2 (VDE 0660-101)	
Rated operational voltage U_n	1P, 1P+N: 230 V AC; 2P, 3P, 4P, 3P+N: 400 V AC
Max. power frequency recovery voltage U_{max}	1P, 1P+N: 253 V AC; 2P, 3P, 4P, 3P+N: 440 V AC
Min. operating voltage	12 V AC
Rated ultimate short-circuit breaking capacity I_{cu}	6 kA
Rated service short-circuit breaking capacity I_{cs}	6 kA
Rated impulse withstand voltage U_{imp} (1.2/50 μ s)	4 kV (test voltage 6.2 kV at sea level, 5 kV at 2,000 m)
Dielectrical test voltage	2 kV (50/60 Hz, 1 min.)
Reference temperature for tripping characteristics	B, C: 55 °C
Electrical endurance	10,000 ops. (AC); one cycle 2 s - ON, 28 s - OFF
Mechanical data	
Housing	Insulation group I, RAL 7035
Toggle	Insulation group II, black, sealable
Contact position indication	Real CPI (red ON/green OFF)
Protection degree acc. to DIN EN 60529	IP20 ¹⁾ , IP40 in enclosure with cover
Mechanical endurance	20,000 ops.
Shock resistance acc. to DIN EN 60068-2-27	25 g, 2 shocks, 13 ms
Vibration resistance acc. to DIN EN 60068-2-6	5 g, 20 cycles at 5...150...5 Hz at 0.8 I_n
Environmental conditions (Damp heat cyclic) acc. to DIN EN 60068-2-30	28 cycles with 55 °C/90-96 % and 25 °C/95-100 %
Ambient temperature	-25 ... +55 °C
Storage temperature	-40 ... +70 °C

¹⁾ Also fulfilling the requirements acc. to the protection degree IPXXB

Miniature Circuit Breaker S 200 80A-100A

Technical data and tripping characteristics

S 200 80A-100A	
Installation	
Terminal	Failsafe bi-directional cache clamp
Cross-section of conductors (top/bottom)	solid, stranded: 50 mm ² / 50 mm ² flexible: 50 mm ² / 50 mm ²
Cross-section of busbars (top/bottom)	16 mm ² / 16 mm ²
Torque	3.0 Nm
Screwdriver	Nr. 2 Pozidriv
Mounting	On DIN rail 35 mm acc. to EN 60715 by fast clip
Mounting position	any
Supply	any
Dimensions and weight	
Mounting dimensions acc. to DIN 43880	Mounting dimension 1
Pole dimensions (H x T x B)	88.8 x 69 x 17.5
Pole weight	approx. 126 g
Combination with auxiliary elements	
Auxiliary contact	Yes
Signal/auxiliary contact	Yes
Shunt trip	Yes
Unervoltage release	Yes
Motor Operating Device	Yes

Tripping characteristics

Acc. to	Tripping characteristics	Rated current I_n	Thermal release ¹⁾			Electromagnetic release ²⁾	
			Currents: conventional non-tripping current I_1	conventional tripping current I_2	Tripping time	Range of instantaneous tripping	Tripping time
DIN EN 60898-1 (VDE 0641-11)	B	80 up to	$1.13 \cdot I_n$		> 2 h	$3 \cdot I_n$	0.1 ... 90 s
		100 A		$1.45 \cdot I_n$	< 2 h	$5 \cdot I_n$	< 0.1 s
	C	80 up to	$1.13 \cdot I_n$		> 2 h	$5 \cdot I_n$	0.1 ... 30 s
		100 A		$1.45 \cdot I_n$	< 2 h	$10 \cdot I_n$	< 0.1 s

¹⁾ The thermal releases are calibrated to a nominal reference ambient temperature; for B and C the reference value is 30 °C. In the case of higher ambient temperatures, the current values fall by approx. 6 % for each 10 K temperature rise.

²⁾ The indicated tripping values of electromagnetic tripping devices apply to a frequency of 50/60 Hz. The thermal release operates independent of frequency.

Miniature Circuit Breaker S 200 80A-100A

Tripping characteristics

B characteristic

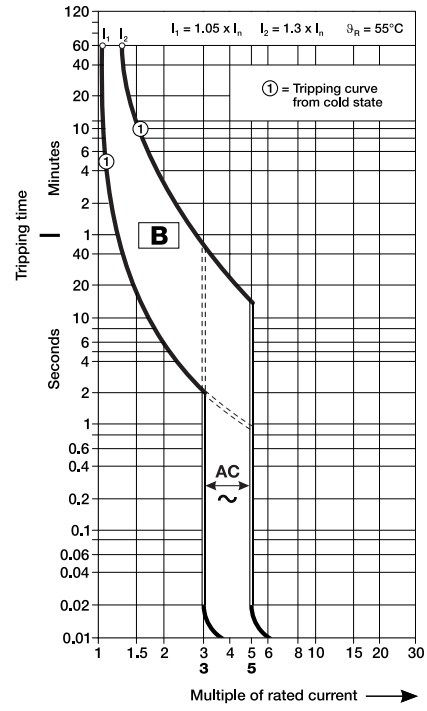
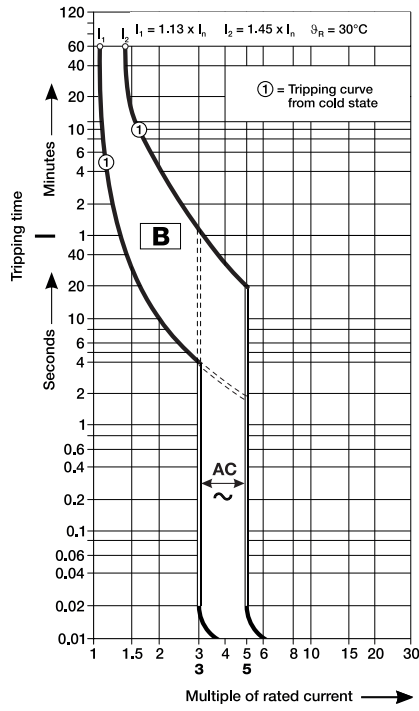

C characteristic

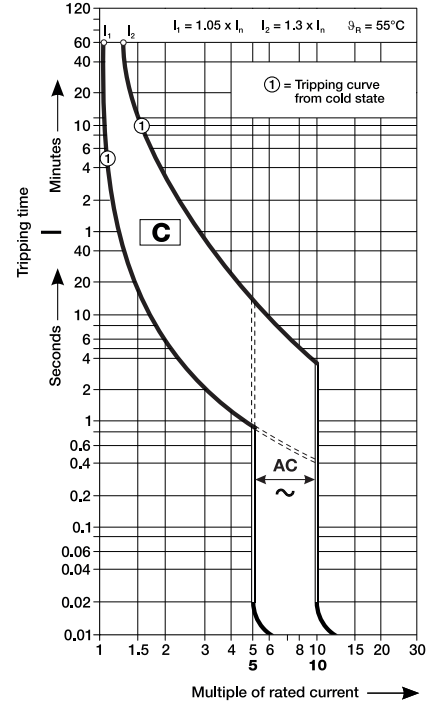
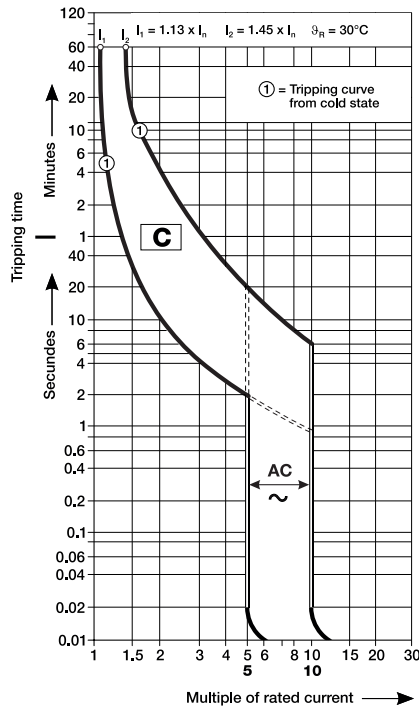

Miniature Circuit Breaker S 200 80A-100A

Derating, internal resistance and power loss

Derating

Deviating ambient temperature

For installations of miniature circuit breakers at other temperatures than the reference value derating factors have to be considered. The rated value of the current of a miniature circuit breaker refers to a reference ambient temperature of 30 °C for circuit breakers with the characteristics B and C.

The following table contains the derating of the load capability at ambient temperatures from -40 °C to 70 °C for the characteristics B and C:

Charac- teristic	Rated current I_n A	Maximum operating current at ambient temperature T											
		- 40 °C	- 30 °C	- 20 °C	10 °C	0	+ 10 °C	+ 20 °C	+ 30 °C	+ 40 °C	+ 50 °C	+ 60 °C	+ 70 °C
B, C	80	96.8	94.4	92.0	89.6	87.2	84.8	82.4	80.0	77.6	75.2	72.8	70.4
	100	121.0	118.0	115.0	112.0	109.0	106.0	103.0	100.0	97.0	94.0	91.0	88.0

Influence of adjacent devices

If several miniature circuit breakers are installed directly side by side with high load on all poles, a correction factor has to be applied to the rated current (see table). If distance pieces are used, the factor is not to be considered.

No. of adjacent devices	Factor F
1	1
2, 3	0.9
4, 5	0.8
≥ 6	0.75

Example

Installation of 8 adjacent miniature circuit breakers S201-C80 at 40 °C ambient temperature

Rated current $I_n = 80$ A

Max. operating current at 40 °C = 75 A (see table above)

Factor F = 0.75 (see left table)

$I_n = 75$ A x 0.75 = 56.3 A

Result: The operating current can only add up to max. 56.3 A

Internal resistance and power loss

Internal resistance and power loss per pole

Tripping characteristic	Rated current I_n A	Internal resistance R_i mΩ	Power loss P_v W
B, C	80	0.9	8.1
B, C	100	0.8	9.8

Internal resistances are subject to application-specific and environment-specific conditions and are therefore to be considered as typical values.

Miniature Circuit Breaker S 200 80A-100A

Accessories and dimensional drawing

Accessory overview

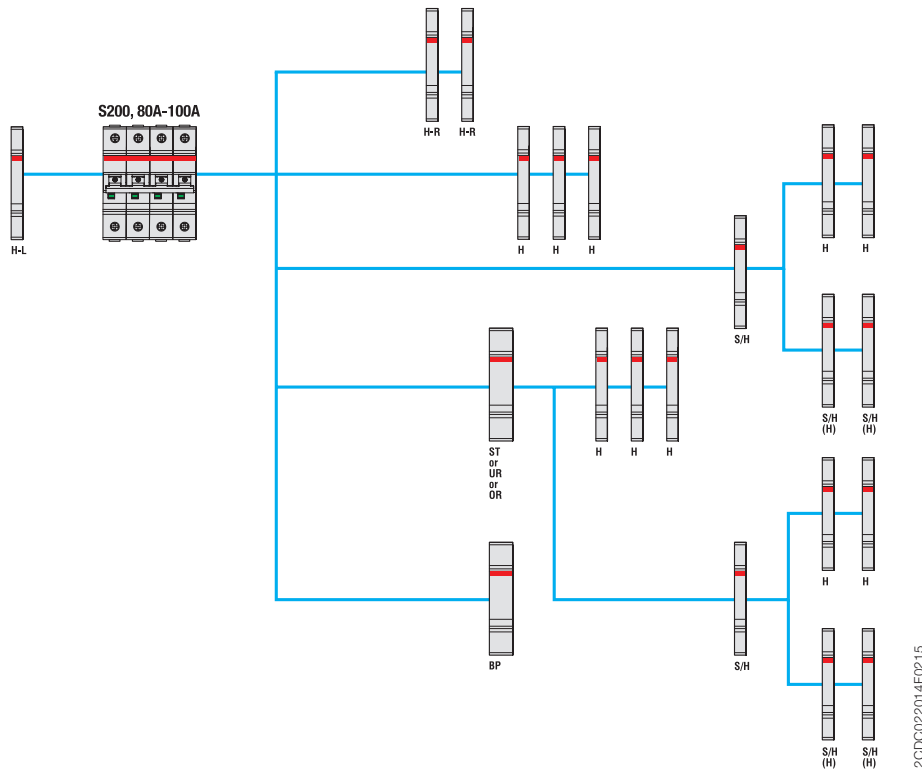

2CDC022014F0215

H	Auxiliary contact (change-over contact)	S2C-H6R	UR	Undervoltage release	S2C-UA
H-R	Auxiliary contact	S2C-H6-...R	OR	Overvoltage release	S2C-OVP
S/H	Signal/Auxiliary contact	S2C-S/H6R	H-L	Auxiliary contact	S2C-H...L
S/H (H)	Signal/Auxiliary contact used as auxiliary contact	S2C-S/H6R	BP	Mechanical tripping device	S2C-BP
ST	Shunt trip	S2C-A...			

Dimensional drawing

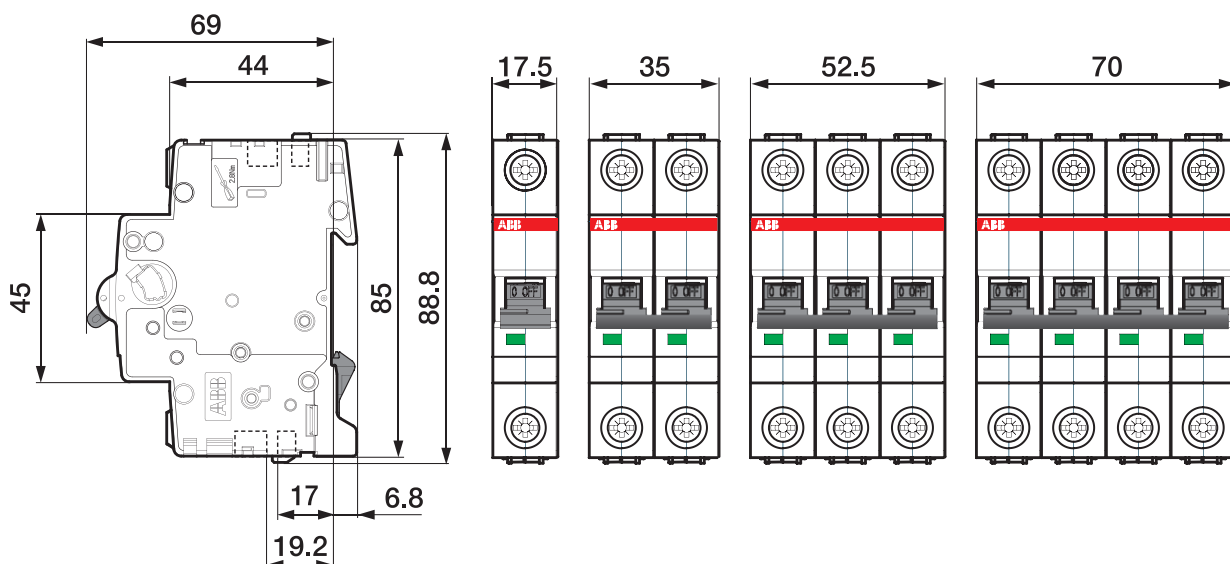

2CDC022026F0014

Miniature Circuit Breaker S 200 80A-100A

Ordering data



S 201 80-100A

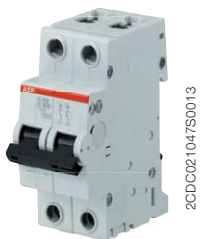

S 202 80-100A



S 203 80-100A



S 204 80-100A



S 201 80-100A NA

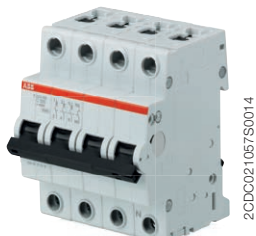

S 203 80-100A NA

Number of poles	Rated current I_n A	EAN	Type	Order code	Packing unit PCS	Weight 1 PC kg
B characteristic						
1	80	4016779916516	S201-B80	2CDS251001R0805	10	0.128
	100	4016779916530	S201-B100	2CDS251001R0825	10	0.128
2	80	4016779916677	S202-B80	2CDS252001R0805	5	0.256
	100	4016779916691	S202-B100	2CDS252001R0825	5	0.256
3	80	4016779916271	S203-B80	2CDS253001R0805	1	0.384
	100	4016779916295	S203-B100	2CDS253001R0825	1	0.384
4	80	4016779916431	S204-B80	2CDS254001R0805	1	0.512
	100	4016779916455	S204-B100	2CDS254001R0825	1	0.512
1+NA	80	4016779916592	S201-B80NA	2CDS251103R0805	5	0.256
	100	4016779916615	S201-B100NA	2CDS251103R0825	5	0.256
3+NA	80	4016779916356	S203-B80NA	2CDS253103R0805	1	0.512
	100	4016779916370	S203-B100NA	2CDS253103R0825	1	0.512
C characteristic						
1	80	4016779916509	S201-C80	2CDS251001R0804	10	0.128
	100	4016779916523	S201-C100	2CDS251001R0824	10	0.128
2	80	4016779916660	S202-C80	2CDS252001R0804	5	0.256
	100	4016779916684	S202-C100	2CDS252001R0824	5	0.256
3	80	4016779916264	S203-C80	2CDS253001R0804	1	0.384
	100	4016779916288	S203-C100	2CDS253001R0824	1	0.384
4	80	4016779916424	S204-C80	2CDS254001R0804	1	0.512
	100	4016779916448	S204-C100	2CDS254001R0824	1	0.512
1+NA	80	4016779916585	S201-C80NA	2CDS251103R0804	5	0.256
	100	4016779916608	S201-C100NA	2CDS251103R0824	5	0.256
3+NA	80	4016779916349	S203-C80NA	2CDS253103R0804	1	0.512
	100	4016779916363	S203-C100NA	2CDS253103R0824	1	0.512

Contact

ABB STOTZ-KONTAKT GmbH

Eppelheimer Straße 82
69123 Heidelberg, Germany
Phone: +49 (0) 6221 7 01-0
Fax: +49 (0) 6221 7 01-13 25
E-Mail: info.desto@de.abb.com

You can find the address of your
local sales organization on the
ABB home page
<http://www.abb.com/contacts>
-> Low Voltage Products and Systems

Note:

We reserve the right to make technical changes or modify the contents of this document without prior notice. With regard to purchase orders, the agreed particulars shall prevail. ABB AG does not accept any responsibility whatsoever for potential errors or possible lack of information in this document.

We reserve all rights in this document and in the subject matter and illustrations contained therein. Any reproduction, disclosure to third parties or utilization of its contents – in whole or in parts – is forbidden without prior written consent of ABB AG.

Copyright© 2015 ABB
All rights reserved