

BMXDRA1605

discrete output module M340 - 16 outputs - relay - 24 V DC



Main

Range of product	Modicon X80
Product or component type	Discrete output module
Discrete output number	16 conforming to EN/IEC 61131-2
Discrete output type	Relay
Discrete output voltage	24 V 19...30 V DC 240 V 200...264 V AC

Complementary

[I _{th}] conventional free air thermal current	2 A
Insulation resistance	> 10 MOhm 500 V DC
Power dissipation in W	<= 3 W
Response time on output	<= 10 ms activation <= 12 ms deactivation
Typical current consumption	100 mA at 3.3 V DC
MTBF reliability	2463296 H
Protection type	External overload protection External short-circuit protection Overvoltage protection, inductive AC network Overvoltage protection, inductive DC network
Output overload protection	Use 1 fast blow fuse per channel or group of channel
Output overvoltage protection	Use discharge diode on each output DC Use RC circuit on each output AC Use ZNO surge limiter on each output AC
Output short-circuit protection	Use 1 fast blow fuse per channel or group of channel
Minimum switching current	1 mA 5 V DC
Electrical durability	100000 cycles AC-14 240 VA 240 V 0.7 100000 cycles AC-14 300 VA 200 V 0.7 100000 cycles AC-15 120 VA 240 V 0.35 100000 cycles AC-15 200 VA 200 V 0.35 100000 cycles DC-13 10 W 100 V 100000 cycles DC-13 24 W 24 V 300000 cycles AC-14 72 VA 240 V 0.7 300000 cycles AC-14 80 VA 200 V 0.7 300000 cycles AC-15 36 VA 240 V 0.35 300000 cycles AC-15 60 VA 200 V 0.35 300000 cycles DC-13 3 W 100 V 300000 cycles DC-13 7.2 W 24 V
Status LED	1 LED green for RUN 1 LED per channel green for channel diagnostic 1 LED red for ERR 1 LED red for I/O
Product weight	0.15 kg

Environment

IP degree of protection	IP20
product certifications	CE CSA UL RCM Merchant Navy

The information provided in this documentation contains general descriptions and/or technical characteristics of the performance of the products contained herein. This documentation is not intended as a substitute for and is not to be used for determining suitability or reliability of these products for specific user applications. It is the duty of any such user or integrator to perform the appropriate and complete risk analysis, evaluation and testing of the products with respect to the relevant specific application or use thereof. Neither Schneider Electric Industries SAS nor any of its affiliates or subsidiaries shall be responsible or liable for misuse of the information contained herein.

standards	EN/IEC 61131-2 EN/IEC 61010-2-201 UL 61010-2-201 CSA C22.2 No 61010-2-201
dielectric strength	2000 V AC at 50/60 Hz 1 min
vibration resistance	3 gn
shock resistance	30 gn
ambient air temperature for storage	-40...85 °C
ambient air temperature for operation	0...60 °C
relative humidity	5...95 % without condensation 55 °C
protective treatment	TC
operating altitude	0...2000 m 2000...5000 m (with derating factor)

Offer Sustainability

Sustainable offer status	Green Premium product
RoHS (date code: YYWW)	Compliant - since 0722 - Schneider Electric declaration of conformity
REACH	Reference not containing SVHC above the threshold
Product environmental profile	Available
Product end of life instructions	Available

Modules Mounted on Racks

Dimensions

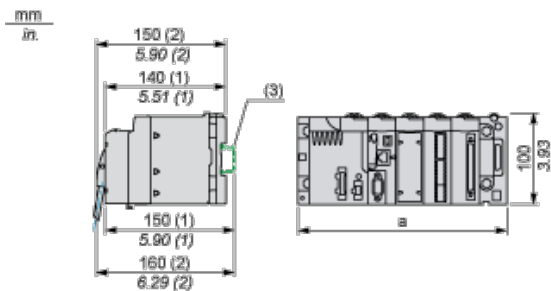

- (1) With removable terminal block (cage, screw or spring).
 (2) With FCN connector.
 (3) On AM1 ED rail: 35 mm wide, 15 mm deep. Only possible with BMXXBP0400/0400H/0600/0600H/0800/0800H rack.

Rack references	a in mm	a in in.
BMXXBP0400 and BMXXBP0400H	242.4	09.54
BMXXBP0600 and BMXXBP0600H	307.6	12.11
BMXXBP0800 and BMXXBP0800H	372.8	14.68
BMXXBP1200 and BMXXBP1200H	503.2	19.81

Connecting the Module

Output Circuit Diagram

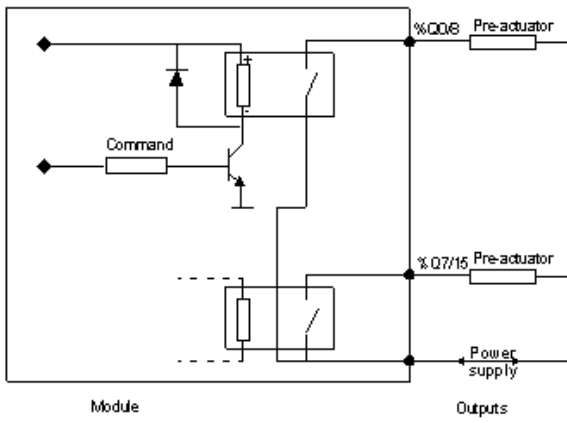

Module Connection

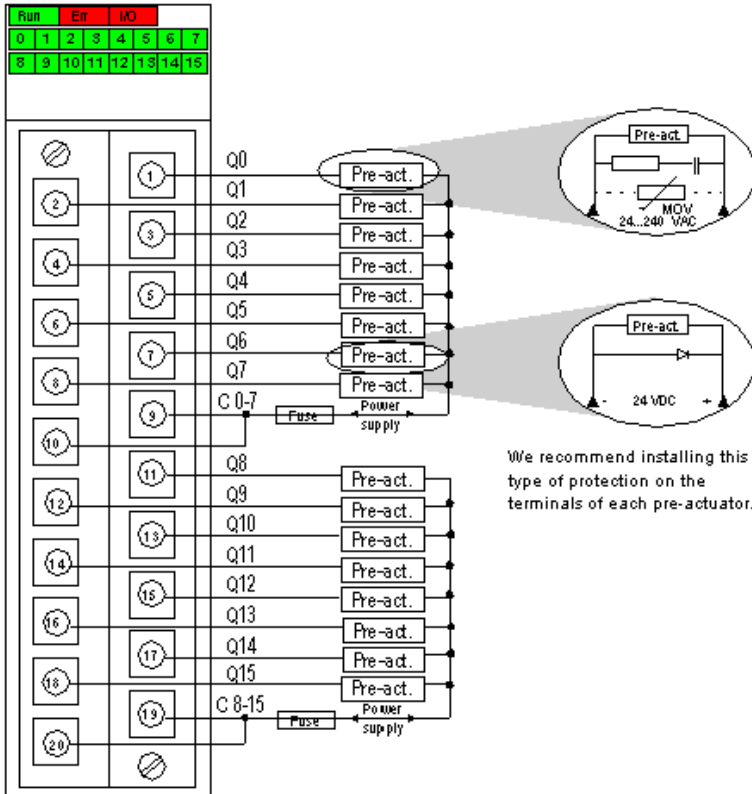

We recommend installing this type of protection on the terminals of each pre-actuator.

power 24 VDC or 24...240 VAC supply

fuse 1 fast blow fuse of 12 A for each 8-channel group