



Trade Audio Visual Products

**TRADE
MADE**
QUALITY MATERIALS FOR
THE TRADESMAN IN MIND

★ ★ ★ ★ ★
**100%
Australian
Owned**

Double Articulated TV Bracket for 23"-55" Screens

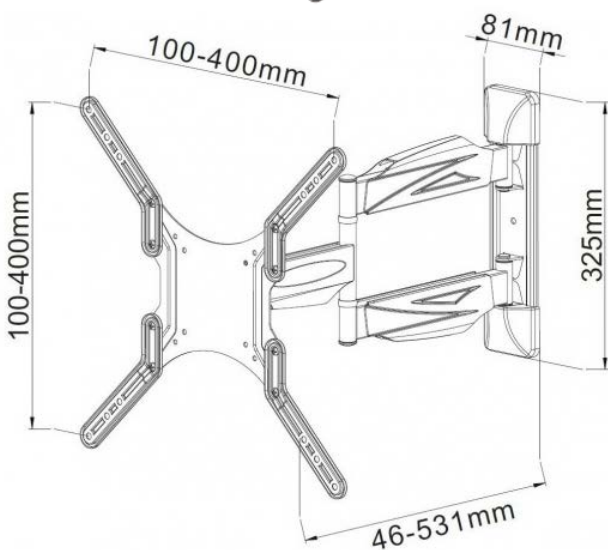

Digital Life Double Articulated TV Bracket suitable for LCD/LED TV screens 23" to 55". Fold flat to the wall 35mm, holds 35Kg with cable management for a clean finish to your installation. Single stud mount, suits VESA mounting patterns up to 400mm x 400mm. One of easiest Television brackets to install.

Product Code: PLB11M

- For screens 23" to 55"
- Max VESA: 400mm x 400mm
- Max Weight: 35Kg
- Folds flat to wall 35mm
- -2° to +12° tilt
- Cable Management
- Single Stud Mount

Available Colours



Black