



Shower Light & Exhaust

INLINE EXHAUST KIT WITH LED LIGHT

- Energy saving LED light
- Long life ball bearing motor
- Easy to install
- Full ducting kit included



LOW MED HIGH



DIGITAL INFO

Scan here using a QR Code reader application on your smart phone or visit www.ventair.com.au for the digital version of this info!



Shower Light & Exhaust



INLINE EXHAUST KIT WITH LED LIGHT

150mm Inline exhaust fan kit including a modern internal fascia with 10w LED centre light, External fixed grille and 4m Aluminium Ducting.

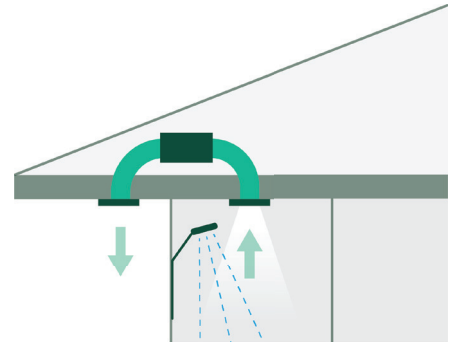

EXHAUST

Air Delivery: 210m³H
Motor Power: 25 watts
Noise Level: 39dB(A)
Ball Bearing: Yes

Duct Outlet: 150mm
Draft Stopper: Yes

LIGHT

Light Type: LED Panel
Light Wattage: 10 watts
Lumens: 855Lm
Light Colour: 4200K Natural
Beam Angle:

DIMENSIONS

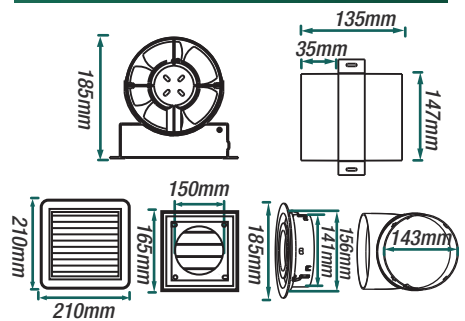

INSTALLATION

Cut Out Size: 158mm Dia
Recommended
Min Install Depth: 200mm

IP Rating: IPX4
Installation: Qualified Electrician Needed

SHIPPING

Packaging Size: 530 x 205 x 225mm
Gross Weight: 3kg

Carton Size: 872 x 550 x 225mm
Carton Weight: 12kg
Carton Qty: 4 units

INCLUDES

- 1 x Inline exhaust motor
- 1 x External grille
- 1 x Internal air intake grille with LED light
- 1 x 4m Aluminium Ducting (150mm)

AVAILABLE EXTRAS

- VAD150** 6m Alum Ducting
- VTROTIMER** 1-25min Run-on-Timer
- VTMSSENSOR** 1-20min Motion Sensor
- V150GS** 150mm Gravity Shutter external grille



Ventair is leading the Industry by ensuring all airflow data is gathered in accordance with International industry standard ISO 580-1997.

Model	Colour	Outer Carton	EAN13 Barcode
VEDLKWH	White	19339310006852	9 339310 006855 >



+61 3 9775 0556
 +61 3 9775 0775
 sales@ventair.com.au

22 Silkwood Rise, Carrum Downs Vic 3201
 www.ventair.com.au

WHOLLY AUSTRALIAN OWNED COMPANY