

Modicon M221

Logic Controller

User Guide

05/2024



Table of Contents



1 Modicon M221 Logic Controller Programming Guide.	Part I
2 Modicon M221 Logic Controller Advanced Functions Library Guide.	Part II
3 Modicon M221 Logic Controller Hardware Guide.	Part III
4 Modicon TMH2GDB - Remote Graphic Display User Guide.	Part IV
5 Modicon TMC2 - Cartridges Programming Guide.	Part V
6 Modicon TMC2 - Cartridges Hardware Guide.	Part VI

Modicon M221

Logic Controller

Programming Guide

EIO0000003297.03
03/2024



Legal Information

The information provided in this document contains general descriptions, technical characteristics and/or recommendations related to products/solutions.

This document is not intended as a substitute for a detailed study or operational and site-specific development or schematic plan. It is not to be used for determining suitability or reliability of the products/solutions for specific user applications. It is the duty of any such user to perform or have any professional expert of its choice (integrator, specifier or the like) perform the appropriate and comprehensive risk analysis, evaluation and testing of the products/solutions with respect to the relevant specific application or use thereof.

The Schneider Electric brand and any trademarks of Schneider Electric SE and its subsidiaries referred to in this document are the property of Schneider Electric SE or its subsidiaries. All other brands may be trademarks of their respective owner.

This document and its content are protected under applicable copyright laws and provided for informative use only. No part of this document may be reproduced or transmitted in any form or by any means (electronic, mechanical, photocopying, recording, or otherwise), for any purpose, without the prior written permission of Schneider Electric.

Schneider Electric does not grant any right or license for commercial use of the document or its content, except for a non-exclusive and personal license to consult it on an "as is" basis.

Schneider Electric reserves the right to make changes or updates with respect to or in the content of this document or the format thereof, at any time without notice.

To the extent permitted by applicable law, no responsibility or liability is assumed by Schneider Electric and its subsidiaries for any errors or omissions in the informational content of this document, as well as any non-intended use or misuse of the content thereof.

Table of Contents

Safety Information	7
About the Book.....	8
Introduction	15
About the Modicon M221 Logic Controller	16
TM221C Logic Controller Description	16
TM221M Logic Controller Description	21
Configuration Features	25
Objects	25
Objects.....	25
Object Types.....	26
Addressing I/O Objects.....	29
Maximum Number of Objects	31
Task Structure	35
Tasks and Scan Modes.....	35
Maximum Number of Tasks and Priorities.....	37
Controller States and Behaviors.....	37
Controller States Diagram.....	38
Controller States Description.....	39
Controller State Transitions.....	41
Persistent Variables.....	44
Output Behavior.....	45
Post Configuration	48
Post Configuration.....	49
Post Configuration File Management	50
Configuring the M221 Logic Controller	52
How to Configure a Controller.....	53
Building a Configuration	53
Optional I/O Expansion Modules	57
Configuring the M221 Logic Controller.....	61
Updating Firmware using Executive Loader Wizard	62
Embedded Input/Output Configuration	63
Digital Input Configuration	63
Configuring Digital Inputs.....	63
Digital Output Configuration.....	66
Configuring Digital Outputs	66
Analog Input Configuration	67
Configuring Analog Inputs.....	67
High Speed Counter Configuration	69
Configuring High Speed Counters	69
Configuring Dual Phase and Single Phase Counters.....	72
Configuring Frequency Meter.....	75
Pulse Generator Configuration.....	77
Configuring Pulse Generators	77
Configuring Pulse (%PLS)	79
Configuring Pulse Width Modulation (%PWM).....	81
Configuring Pulse Train Output (%PTO).....	82
Configuring Frequency Generator (%FREQGEN).....	84
I/O Bus Configuration.....	86

I/O Configuration General Description	86
Maximum Hardware Configuration	90
Configuring Cartridges and Expansion Modules	94
Embedded Communication Configuration.....	95
Ethernet Configuration	95
Configuring Ethernet Network	95
Configuring Modbus TCP or Modbus TCP IOScanner	101
Configuring EtherNet/IP	109
Serial Line Configuration	122
Configuring Serial Lines.....	122
Configuring Modbus and ASCII Protocols	125
Configuring the TMH2GDB Remote Graphic Display	127
Configuring Modbus Serial IOScanner	128
Adding a Device on the Modbus Serial IOScanner	128
Supported Modbus Function Codes	135
Supported Modbus Function Codes.....	135
State Machine Diagram for Modbus IOscanner	137
State Machine Diagram for Modbus IOscanner.....	137
SD Card.....	138
File Management Operations.....	138
SD Card Supported File Types.....	139
Clone Management.....	140
Firmware Management	141
Application Management.....	145
Post Configuration Management.....	146
Error Log Management	148
Memory Management: Backing Up and Restoring Controller Memory.....	151
Programming the M221 Logic Controller	152
I/O Objects.....	153
Digital Inputs (%I)	153
Digital Outputs (%Q)	154
Analog Inputs (%IW)	154
Analog Outputs (%QW).....	156
Network Objects	157
Input Assembly (EtherNet/IP) Objects (%QWE)	157
Output Assembly (EtherNet/IP) Objects (%IWE).....	158
Input Registers (Modbus TCP) Objects (%QWM)	159
Output Registers (Modbus TCP) Objects (%IWM)	160
Digital Input (IOScanner) Objects (%IN).....	161
Digital Output (IOScanner) Objects (%QN)	162
Input Register (IOScanner) Objects (%IWN)	163
Output Register (IOScanner) Objects (%QWN)	164
Modbus IOScanner Network Diagnostic Codes (%IWNS)	166
System Objects	167
System Bits (%S).....	167
System Words (%SW).....	174
Input Channel Status (%IWS)	189
Output Channel Status (%QWS)	191
Glossary	193

Safety Information

Important Information

Read these instructions carefully, and look at the equipment to become familiar with the device before trying to install, operate, service, or maintain it. The following special messages may appear throughout this documentation or on the equipment to warn of potential hazards or to call attention to information that clarifies or simplifies a procedure.



The addition of this symbol to a “Danger” or “Warning” safety label indicates that an electrical hazard exists which will result in personal injury if the instructions are not followed.



This is the safety alert symbol. It is used to alert you to potential personal injury hazards. Obey all safety messages that follow this symbol to avoid possible injury or death.

⚠ DANGER
DANGER indicates a hazardous situation which, if not avoided, will result in death or serious injury.

⚠ WARNING
WARNING indicates a hazardous situation which, if not avoided, could result in death or serious injury.

⚠ CAUTION
CAUTION indicates a hazardous situation which, if not avoided, could result in minor or moderate injury.

NOTICE
NOTICE is used to address practices not related to physical injury.

Please Note

Electrical equipment should be installed, operated, serviced, and maintained only by qualified personnel. No responsibility is assumed by Schneider Electric for any consequences arising out of the use of this material.

A qualified person is one who has skills and knowledge related to the construction and operation of electrical equipment and its installation, and has received safety training to recognize and avoid the hazards involved.

About the Book

Document Scope

This document describes the configuration and programming of the Modicon M221 Logic Controller for EcoStruxure Machine Expert - Basic. For further information, refer to the separate documents provided in the EcoStruxure Machine Expert - Basic online help.

Validity Note

This document has been updated for the release of EcoStruxure™ Machine Expert - Basic V1.3.

Available Languages of this Document

This document is available in these languages:

- English (EIO0000003297)
- French (EIO0000003298)
- German (EIO0000003299)
- Spanish (EIO0000003300)
- Italian (EIO0000003301)
- Chinese (EIO0000003302)
- Portuguese (EIO0000003303)
- Turkish (EIO0000003304)

Related Documents

Title of Documentation	Reference Number
EcoStruxure Machine Expert - Basic - Operating Guide	EIO0000003281 (ENG)
	EIO0000003282 (FRA)
	EIO0000003283 (GER)
	EIO0000003284 (SPA)
	EIO0000003285 (ITA)
	EIO0000003286 (CHS)
	EIO0000003287 (POR)
EIO0000003288 (TUR)	
EcoStruxure Machine Expert - Basic Generic Functions - Library Guide	EIO0000003289 (ENG)
	EIO0000003290 (FRE)
	EIO0000003291 (GER)
	EIO0000003292 (SPA)
	EIO0000003293 (ITA)
	EIO0000003294 (CHS)
	EIO0000003295 (POR)
EIO0000003296 (TUR)	

Title of Documentation	Reference Number
Modicon M221 Logic Controller Advanced Functions - Library Guide	EIO0000003305 (ENG) EIO0000003306 (FRE) EIO0000003307 (GER) EIO0000003308 (SPA) EIO0000003309 (ITA) EIO0000003310 (CHS) EIO0000003311 (POR) EIO0000003312 (TUR)
Modicon M221 Logic Controller - Hardware Guide	EIO0000003313 (ENG) EIO0000003314 (FRE) EIO0000003315 (GER) EIO0000003316 (SPA) EIO0000003317 (ITA) EIO0000003318 (CHS) EIO0000003319 (POR) EIO0000003320 (TUR)
TMH2GDB Remote Graphic Display - User Guide	EIO0000003321 (ENG) EIO0000003322 (FRA) EIO0000003323 (GER) EIO0000003324 (SPA) EIO0000003325 (ITA) EIO0000003326 (CHS) EIO0000003327 (POR) EIO0000003328 (TUR)
Modicon TMC2 Cartridge - Programming Guide	EIO0000003329 (ENG) EIO0000003330 (FRE) EIO0000003331 (GER) EIO0000003332 (SPA) EIO0000003333 (ITA) EIO0000003334 (CHS) EIO0000003335 (POR) EIO0000003336 (TUR)
Modicon TMC2 Cartridge - Hardware Guide	EIO0000003337 (ENG) EIO0000003338 (FRE) EIO0000003339 (GER) EIO0000003340 (SPA) EIO0000003341 (ITA) EIO0000003342 (CHS) EIO0000003343 (POR) EIO0000003344 (TUR)

Title of Documentation	Reference Number
Modicon TM3 Expansion Modules Configuration - Programming Guide	EIO0000003345 (ENG) EIO0000003346 (FRE) EIO0000003347 (GER) EIO0000003348 (SPA) EIO0000003349 (ITA) EIO0000003350 (CHS) EIO0000003351 (POR) EIO0000003352 (TUR)
Modicon TM3 Digital I/O Modules - Hardware Guide	EIO0000003125 (ENG) EIO0000003126 (FRE) EIO0000003127 (GER) EIO0000003128 (SPA) EIO0000003129 (ITA) EIO0000003130 (CHS) EIO0000003424 (POR) EIO0000003425 (TUR)
Modicon TM3 Analog I/O Modules - Hardware Guide	EIO0000003131 (ENG) EIO0000003132 (FRE) EIO0000003133 (GER) EIO0000003134 (SPA) EIO0000003135 (ITA) EIO0000003136 (CHS) EIO0000003426 (POR) EIO0000003427 (TUR)
Modicon TM3 Expert Modules - Hardware Guide	EIO0000003137 (ENG) EIO0000003138 (FRE) EIO0000003139 (GER) EIO0000003140 (SPA) EIO0000003141 (ITA) EIO0000003142 (CHS) EIO0000003428 (POR) EIO0000003429 (TUR)
Modicon TM3 Safety Modules - Hardware Guide	EIO0000003353 (ENG) EIO0000003354 (FRE) EIO0000003355 (GER) EIO0000003356 (SPA) EIO0000003357 (ITA) EIO0000003358 (CHS) EIO0000003359 (POR) EIO0000003360 (TUR)

Title of Documentation	Reference Number
Modicon TM3 Transmitter and Receiver Modules - Hardware Guide	EIO0000003143 (ENG) EIO0000003144 (FRE) EIO0000003145 (GER) EIO0000003146 (SPA) EIO0000003147 (ITA) EIO0000003148 (CHS) EIO0000003430 (POR) EIO0000003431 (TUR)
Modicon TM2 Expansion Modules Configuration - Programming Guide	EIO0000003432 (ENG) EIO0000003433 (FRE) EIO0000003434 (GER) EIO0000003435 (SPA) EIO0000003436 (ITA) EIO0000003437 (CHS)
Modicon TM2 Digital I/O Modules - Hardware Guide	EIO0000000028 (ENG) EIO0000000029 (FRE) EIO0000000030 (GER) EIO0000000031 (SPA) EIO0000000032 (ITA) EIO0000000033 (CHS)
Modicon TM2 Analog I/O Modules - Hardware Guide	EIO0000000034 (ENG) EIO0000000035 (FRE) EIO0000000036 (GER) EIO0000000037 (SPA) EIO0000000038 (ITA) EIO0000000039 (CHS)
SR2MOD02 and SR2MOD03 Wireless Modem - User Guide	EIO0000001575 (ENG)

To find documents online, visit the Schneider Electric download center (www.se.com/ww/en/download/).

Product Related Information

▲ WARNING

LOSS OF CONTROL

- Perform a Failure Mode and Effects Analysis (FMEA), or equivalent risk analysis, of your application, and apply preventive and detective controls before implementation.
- Provide a fallback state for undesired control events or sequences.
- Provide separate or redundant control paths wherever required.
- Supply appropriate parameters, particularly for limits.
- Review the implications of transmission delays and take actions to mitigate them.
- Review the implications of communication link interruptions and take actions to mitigate them.
- Provide independent paths for control functions (for example, emergency stop, over-limit conditions, and error conditions) according to your risk assessment, and applicable codes and regulations.
- Apply local accident prevention and safety regulations and guidelines.¹
- Test each implementation of a system for proper operation before placing it into service.

Failure to follow these instructions can result in death, serious injury, or equipment damage.

¹ For additional information, refer to NEMA ICS 1.1 (latest edition), *Safety Guidelines for the Application, Installation, and Maintenance of Solid State Control* and to NEMA ICS 7.1 (latest edition), *Safety Standards for Construction and Guide for Selection, Installation and Operation of Adjustable-Speed Drive Systems* or their equivalent governing your particular location.

▲ WARNING

UNINTENDED EQUIPMENT OPERATION

- Only use software approved by Schneider Electric for use with this equipment.
- Update your application program every time you change the physical hardware configuration.

Failure to follow these instructions can result in death, serious injury, or equipment damage.

Information on Non-Inclusive or Insensitive Terminology

As a responsible, inclusive company, Schneider Electric is constantly updating its communications and products that contain non-inclusive or insensitive terminology. However, despite these efforts, our content may still contain terms that are deemed inappropriate by some customers.

Terminology Derived from Standards

The technical terms, terminology, symbols and the corresponding descriptions in the information contained herein, or that appear in or on the products themselves, are generally derived from the terms or definitions of international standards.

In the area of functional safety systems, drives and general automation, this may include, but is not limited to, terms such as *safety*, *safety function*, *safe state*, *fault*, *fault reset*, *malfunction*, *failure*, *error*, *error message*, *dangerous*, etc.

Among others, these standards include:

Standard	Description
IEC 61131-2:2007	Programmable controllers, part 2: Equipment requirements and tests.
ISO 13849-1:2023	Safety of machinery: Safety related parts of control systems. General principles for design.
EN 61496-1:2013	Safety of machinery: Electro-sensitive protective equipment. Part 1: General requirements and tests.
ISO 12100:2010	Safety of machinery - General principles for design - Risk assessment and risk reduction
EN 60204-1:2006	Safety of machinery - Electrical equipment of machines - Part 1: General requirements
ISO 14119:2013	Safety of machinery - Interlocking devices associated with guards - Principles for design and selection
ISO 13850:2015	Safety of machinery - Emergency stop - Principles for design
IEC 62061:2021	Safety of machinery - Functional safety of safety-related electrical, electronic, and electronic programmable control systems
IEC 61508-1:2010	Functional safety of electrical/electronic/programmable electronic safety-related systems: General requirements.
IEC 61508-2:2010	Functional safety of electrical/electronic/programmable electronic safety-related systems: Requirements for electrical/electronic/programmable electronic safety-related systems.
IEC 61508-3:2010	Functional safety of electrical/electronic/programmable electronic safety-related systems: Software requirements.
IEC 61784-3:2021	Industrial communication networks - Profiles - Part 3: Functional safety fieldbuses - General rules and profile definitions.
2006/42/EC	Machinery Directive
2014/30/EU	Electromagnetic Compatibility Directive
2014/35/EU	Low Voltage Directive

In addition, terms used in the present document may tangentially be used as they are derived from other standards such as:

Standard	Description
IEC 60034 series	Rotating electrical machines
IEC 61800 series	Adjustable speed electrical power drive systems
IEC 61158 series	Digital data communications for measurement and control – Fieldbus for use in industrial control systems

Finally, the term *zone of operation* may be used in conjunction with the description of specific hazards, and is defined as it is for a *hazard zone* or *danger zone* in the *Machinery Directive (2006/42/EC)* and *ISO 12100:2010*.

NOTE: The aforementioned standards may or may not apply to the specific products cited in the present documentation. For more information concerning the individual standards applicable to the products described herein, see the characteristics tables for those product references.

Introduction

What's in This Part

About the Modicon M221 Logic Controller	16
Configuration Features	25

Overview

This part provides general information about the Modicon M221 Logic Controller and its configuration and programming features.

About the Modicon M221 Logic Controller

What's in This Chapter

TM221C Logic Controller Description.....	16
TM221M Logic Controller Description	21

TM221C Logic Controller Description

Overview

The TM221C Logic Controller has various powerful features and can service a wide range of applications.

Software configuration, programming, and commissioning are accomplished with the EcoStruxure Machine Expert - Basic software described in the EcoStruxure Machine Expert - Basic Operating Guide (see EcoStruxure Machine Expert - Basic, Operating Guide) and the M221 Logic Controller - Programming Guide, page 8.

Programming Languages

The M221 Logic Controller is configured and programmed with the EcoStruxure Machine Expert - Basic software, which supports the following IEC 61131-3 programming languages:

- IL: Instruction List
- LD: Ladder Diagram
- Grafcet (List)
- Grafcet (SFC)

Power Supply

The power supply of the TM221C Logic Controller is 24 Vdc (see Modicon M221 Logic Controller, Hardware Guide) or 100...240 Vac (see Modicon M221 Logic Controller, Hardware Guide).

Real Time Clock

The M221 Logic Controller includes a Real Time Clock (RTC) system (see Modicon M221 Logic Controller, Hardware Guide).

Run/Stop

The M221 Logic Controller can be operated externally by the following:

- a hardware Run/Stop switch (see Modicon M221 Logic Controller, Hardware Guide)
- a Run/Stop (see Modicon M221 Logic Controller, Hardware Guide) operation by a dedicated digital input, defined in the software configuration (for more information, refer to [Configuring Digital Inputs](#), page 63.)
- EcoStruxure Machine Expert - Basic software (for more information, refer to [Toolbar](#) (see EcoStruxure Machine Expert - Basic, Operating Guide)).
- a TMH2GDB Remote Graphic Display (for more information, refer to [Controller State Menu](#) (see Modicon TMH2GDB, Remote Graphic Display, User Guide)).

Memory

This table describes the different types of memory:

Memory Type	Size	Used to
RAM	512 kbytes of RAM memory: 256 kbytes for internal variables and 256 kbytes for application and data.	execute the application and contain data
Non-volatile	1.5 Mbytes, of which 256 kbytes is used to back up the application and data in case of power outage.	save the application

Embedded Inputs/Outputs

The following embedded I/O types are available, depending on the controller reference:

- Regular inputs
- Fast inputs associated with counters
- Regular sink/source transistor outputs
- Fast sink/source transistor outputs associated with pulse generators
- Relay outputs
- Analog inputs

Removable Storage

The M221 Logic Controllers include an embedded SD card slot (see Modicon M221 Logic Controller, Hardware Guide).

The Modicon M221 Logic Controller allows the following types of file management with an SD card:

- Clone management, page 140: back up the application, firmware, and post configuration (if it exists) of the logic controller
- Firmware management, page 141: download firmware to the logic controller, to a TMH2GDB Remote Graphic Display , or to TM3 expansion modules
- Application management, page 145: back up and restore the logic controller application, or copy it to another logic controller of the same reference
- Post configuration management, page 146: add, change, or delete the post configuration file of the logic controller
- Error log management, page 148: back up or delete the error log file of the logic controller
- Memory management, page 151: back up and restore memory bits and words from a controller

Embedded Communication Features

The following types of communication ports are available depending on the controller reference:

- Ethernet (see Modicon M221 Logic Controller, Hardware Guide)
- USB Mini-B (see Modicon M221 Logic Controller, Hardware Guide)
- Serial Line 1 (see Modicon M221 Logic Controller, Hardware Guide)

Remote Graphic Display

For more information, refer to the Modicon TMH2GDB Remote Graphic Display - User Guide.

TM221C Logic Controller

Reference	Digital Inputs	Digital Outputs	Analog Inputs	Communication Ports	Power Supply
TM221C16R	5 regular inputs ⁽¹⁾ 4 fast inputs (HSC) ⁽²⁾	7 relay outputs	Yes	1 serial line port 1 USB programming port	100...240 Vac
TM221CE16R			Yes	1 serial line port 1 USB programming port 1 Ethernet port	
TM221C16T	5 regular inputs ⁽¹⁾ 4 fast inputs (HSC) ⁽²⁾	Source outputs	Yes	1 serial line port 1 USB programming port	24 Vdc
TM221CE16T		5 regular transistor outputs 2 fast outputs (PLS/PWM/PTO/ FREQGEN) ⁽³⁾	Yes	1 serial line port 1 USB programming port 1 Ethernet port	
TM221C16U	5 regular inputs ⁽¹⁾ 4 fast inputs (HSC) ⁽²⁾	Sink outputs	Yes	1 serial line port 1 USB programming port	24 Vdc
TM221CE16U		5 regular transistor outputs 2 fast outputs (PLS/PWM/PTO/ FREQGEN) ⁽³⁾		1 serial line port 1 USB programming port 1 Ethernet port	
TM221C24R	10 regular inputs ⁽¹⁾ 4 fast inputs (HSC) ⁽²⁾	10 relay outputs	Yes	1 serial line port 1 USB programming port	100...240 Vac
TM221CE24R			Yes	1 serial line port 1 USB programming port 1 Ethernet port	
TM221C24T		Source outputs	Yes	1 serial line port 1 USB programming port	24 Vdc
TM221CE24T	8 regular transistor outputs 2 fast outputs (PLS/PWM/PTO/ FREQGEN) ⁽³⁾	Yes	1 serial line port 1 USB programming port 1 Ethernet port		

Reference	Digital Inputs	Digital Outputs	Analog Inputs	Communication Ports	Power Supply
TM221C24U	10 regular inputs ⁽¹⁾ 4 fast inputs (HSC) ⁽²⁾	Sink outputs 8 regular transistor outputs	Yes	1 serial line port 1 USB programming port	24 Vdc
TM221CE24U		2 fast outputs (PLS/PWM/PTO/ FREQGEN) ⁽³⁾	Yes	1 serial line port 1 USB programming port 1 Ethernet port	
TM221C40R	20 regular inputs ⁽¹⁾ 4 fast inputs (HSC) ⁽²⁾	16 relay outputs	Yes	1 serial line port 1 USB programming port	100...240 Vac
TM221CE40R			Yes	1 serial line port 1 USB programming port 1 Ethernet port	
TM221C40T		Source outputs 14 regular transistor outputs	Yes	1 serial line port 1 USB programming port	24 Vdc
TM221CE40T		2 fast outputs (PLS/PWM/PTO/ FREQGEN) ⁽³⁾	Yes	1 serial line port 1 USB programming port 1 Ethernet port	
TM221C40U	20 regular inputs ⁽¹⁾ 4 fast inputs (HSC) ⁽²⁾	Sink outputs 12 regular transistor outputs	Yes	1 serial line port 1 USB programming port	24 Vdc
TM221CE40U		4 fast outputs (PLS/PWM/PTO/ FREQGEN) ⁽³⁾	Yes	1 serial line port 1 USB programming port 1 Ethernet port	

NOTE: The TM221C Logic Controller uses removable screw terminal blocks.

(1) The regular inputs have a maximum frequency of 5 kHz.

(2) The fast inputs can be used either as regular inputs or as fast inputs for counting or event functions.

(3) The fast transistor outputs can be used either as regular transistor outputs, for PLS, PWM, PTO, or FREQGEN functions, or reflex outputs for HSC.

Delivery Content

The following figure presents the content of the delivery for a TM221C Logic Controller:

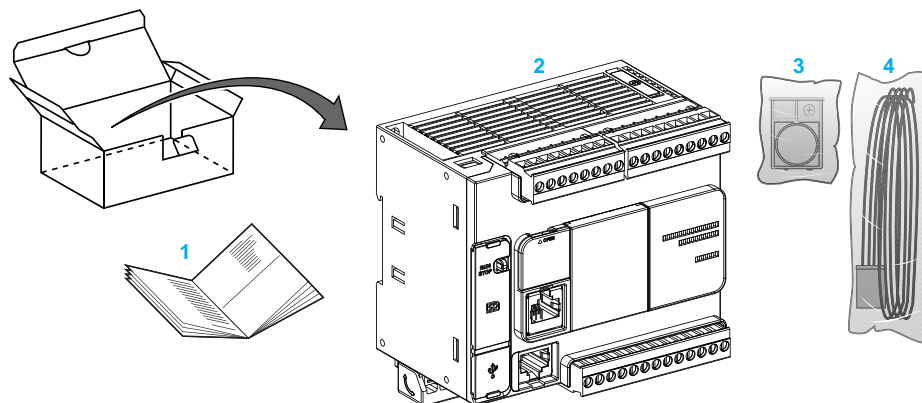

1 TM221C Logic Controller Instruction Sheet

2 TM221C Logic Controller

3 Battery holder with lithium coin battery, type Panasonic BR2032 or Murata CR2032X

4 Analog cable

TM221M Logic Controller Description

Overview

The TM221M Logic Controller has various powerful features and can service a wide range of applications.

Software configuration, programming, and commissioning are accomplished with the EcoStruxure Machine Expert - Basic software described in the EcoStruxure Machine Expert - Basic Operating Guide (see EcoStruxure Machine Expert - Basic, Operating Guide) and the M221 Logic Controller - Programming Guide, page 8.

Programming Languages

The M221 Logic Controller is configured and programmed with the EcoStruxure Machine Expert - Basic software, which supports the following IEC 61131-3 programming languages:

- IL: Instruction List
- LD: Ladder Diagram
- Grafcet (List)
- Grafcet (SFC)

Power Supply

The power supply of the TM221M Logic Controller is 24 Vdc (see Modicon M221 Logic Controller, Hardware Guide).

Real Time Clock

The M221 Logic Controller includes a Real Time Clock (RTC) system (see Modicon M221 Logic Controller, Hardware Guide).

Run/Stop

The M221 Logic Controller can be operated externally by the following:

- a hardware Run/Stop switch (see Modicon M221 Logic Controller, Hardware Guide)
- a Run/Stop (see Modicon M221 Logic Controller, Hardware Guide) operation by a dedicated digital input, defined in the software configuration (for more information, refer to *Configuring Digital Inputs*, page 63)
- EcoStruxure Machine Expert - Basic software (for more information, refer to *Toolbar* (see EcoStruxure Machine Expert - Basic, Operating Guide)).
- a TMH2GDB Remote Graphic Display (for more information, refer to *Controller State Menu*).

Memory

This table describes the different types of memory:

Memory Type	Size	Used to
RAM	512 kbytes of RAM memory: 256 kbytes for internal variables and 256 kbytes for application and data.	execute the application and contains data
Non-volatile	1.5 Mbytes, of which 256 kbytes is used to back up the application and data in case of power outage.	save the application

Embedded Inputs/Outputs

The following embedded I/O types are available, depending on the controller reference:

- Regular inputs
- Fast inputs (HSC)
- Regular transistor outputs
- Fast transistor outputs (PLS/PWM/PTO/FREQGEN)
- Relay outputs
- Analog inputs

Removable Storage

The M221 Logic Controllers include an embedded SD card slot (see Modicon M221 Logic Controller, Hardware Guide).

The Modicon M221 Logic Controller allows the following types of file management with an SD card:

- Clone management, page 140: back up the application, firmware, and post configuration (if it exists) of the logic controller
- Firmware management, page 141: download firmware updates directly to the logic controller, and download firmware to a TMH2GDB Remote Graphic Display
- Application management, page 145: back up and restore the logic controller application, or copy it to another logic controller of the same reference
- Post configuration management, page 146: add, change, or delete the post configuration file of the logic controller
- Error log management, page 148: back up or delete the error log file of the logic controller
- Memory management, page 151: backup/restore of memory bits and words from a controller

Embedded Communication Features

The following communication ports are available on the front panel of the controller, depending on the controller reference:

- Ethernet (see Modicon M221 Logic Controller, Hardware Guide)
- USB Mini-B (see Modicon M221 Logic Controller, Hardware Guide)
- SD Card (see Modicon M221 Logic Controller, Hardware Guide)
- Serial Line 1 (see Modicon M221 Logic Controller, Hardware Guide)
- Serial Line 2 (see Modicon M221 Logic Controller, Hardware Guide)

Remote Graphic Display

For more information, refer to the Modicon TMH2GDB Remote Graphic Display - User Guide.

TM221M Logic Controller

Reference	Digital Input	Digital Output	Analog Input	Communication Ports	Terminal Type
TM221M16R	4 regular inputs ⁽¹⁾ 4 fast inputs (HSC) ⁽²⁾	8 relay outputs	Yes	2 serial line ports 1 USB programming port	Removable screw terminal blocks
TM221M16RG	4 regular inputs ⁽¹⁾ 4 fast inputs (HSC) ⁽²⁾	8 relay outputs	Yes	2 serial line ports 1 USB programming port	Removable spring terminal blocks
TM221ME16R	4 regular inputs ⁽¹⁾ 4 fast inputs (HSC) ⁽²⁾	8 relay outputs	Yes	1 serial line port 1 USB programming port 1 Ethernet port	Removable screw terminal blocks
TM221ME16RG	4 regular inputs ⁽¹⁾ 4 fast inputs (HSC) ⁽²⁾	8 relay outputs	Yes	1 serial line port 1 USB programming port 1 Ethernet port	Removable spring terminal blocks
TM221M16T	4 regular inputs ⁽¹⁾ 4 fast inputs (HSC) ⁽²⁾	6 regular transistor outputs 2 fast transistor outputs (PLS/PWM/PTO/FREQGEN) ⁽³⁾	Yes	2 serial line ports 1 USB programming port	Removable screw terminal blocks
TM221M16TG	4 regular inputs ⁽¹⁾ 4 fast inputs (HSC) ⁽²⁾	6 regular transistor outputs 2 fast transistor outputs (PLS/PWM/PTO/FREQGEN) ⁽³⁾	Yes	2 serial line ports 1 USB programming port	Removable spring terminal blocks
TM221ME16T	4 regular inputs ⁽¹⁾ 4 fast inputs (HSC) ⁽²⁾	6 regular transistor outputs 2 fast transistor outputs (PLS/PWM/PTO/FREQGEN) ⁽³⁾	Yes	1 serial line port 1 USB programming port 1 Ethernet port	Removable screw terminal blocks
TM221ME16TG	4 regular inputs ⁽¹⁾ 4 fast inputs (HSC) ⁽²⁾	6 regular transistor outputs 2 fast transistor outputs (PLS/PWM/PTO/FREQGEN) ⁽³⁾	Yes	1 serial line port USB programming port 1 Ethernet port	Removable spring terminal blocks
TM221M32TK	12 regular inputs ⁽¹⁾ 4 fast inputs (HSC) ⁽²⁾	14 regular transistor outputs 2 fast outputs (PLS/PWM/PTO/FREQGEN) ⁽³⁾	Yes	2 serial line ports 1 USB programming port	HE10 (MIL 20) connectors

Reference	Digital Input	Digital Output	Analog Input	Communication Ports	Terminal Type
TM221ME32TK	12 regular inputs ⁽¹⁾ 4 fast inputs (HSC) ⁽²⁾	14 regular outputs 2 fast outputs (PLS/ PWM/PTO/ FREQGEN) ⁽³⁾	Yes	1 serial line port 1 USB programming port 1 Ethernet port	HE10 (MIL 20) connectors

NOTE: The TM221M Logic Controller uses a 24 Vdc power supply (see Modicon M221 Logic Controller, Hardware Guide).

(1) The regular inputs I2, I3, I4, and I5 have a maximum frequency of 5 kHz. The other regular inputs have a maximum frequency of 100 Hz.

(2) The fast inputs can be used either as regular inputs or as fast inputs for counting or event functions.

(3) The fast transistor outputs can be used as regular transistor outputs, for PLS, PWM, PTO or FREQGEN functions, or reflex outputs for HSC.

Delivery Content

The following figure presents the content of the delivery for a TM221M Logic Controller:

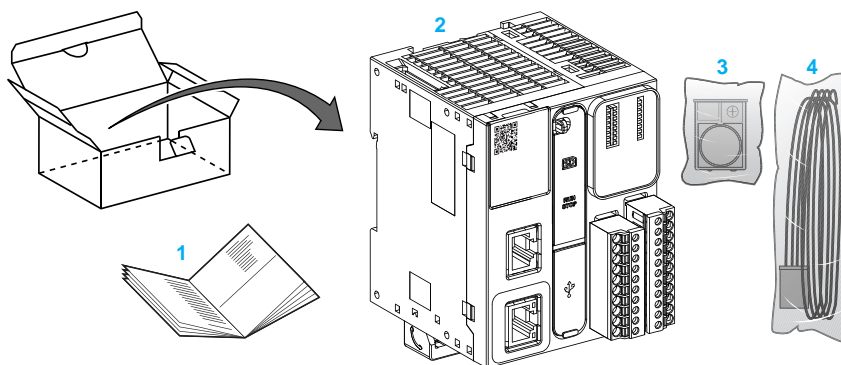

1 TM221M Logic Controller Instruction Sheet

2 TM221M Logic Controller

3 Battery holder with lithium coin battery, type Panasonic BR2032 or Murata CR2032X

4 Analog cable

Configuration Features

What's in This Chapter

Objects.....	25
Task Structure.....	35
Controller States and Behaviors	37
Post Configuration.....	48

Introduction

This chapter provides information related to M221 Logic Controller memory mapping, task, states, behaviors, objects, and functions. The topics explained in this chapter allow the operator to understand the featured specifications of M221 Logic Controller that are primarily needed to configure and program the controller in EcoStruxure Machine Expert - Basic.

Objects

Objects

Overview

In EcoStruxure Machine Expert - Basic, the term *object* is used to represent an area of logic controller memory reserved for use by an application. Objects can be:

- Simple software variables, such as memory bits and words
- Addresses of digital or analog inputs and outputs
- Controller-internal variables, such as system words and system bits
- Predefined system functions or function blocks, such as timers and counters.

Controller memory is either pre-allocated for certain object types, or automatically allocated when an application is downloaded to the logic controller.

Objects can only be addressed by a program once memory has been allocated. Objects are addressed using the prefix %. For example, %MW12 is the address of a memory word, %Q0.3 is the address of an embedded digital output, and %TMO is the address of a *Timer* function block.

Object Types

Introduction

The language object types for the M221 Logic Controller are described in the following table:

Object Type	Object	Object Function	Description
Memory objects	<i>%M</i>	Memory bits	Stores memory bit.
	<i>%MW</i>	Memory words	Stores 16-bit memory word.
	<i>%MD</i>	Memory double words	Stores 32-bit memory word.
	<i>%MF</i>	Memory floating point	Stores memory floating point in a mathematical argument which has a decimal in its expression.
	<i>%KW</i>	Constant words	Stores 16-bit constant word.
	<i>%KD</i>	Constant double words	Stores 32-bit constant word.
	<i>%KF</i>	Constant floating points	Stores constant floating point in a mathematical argument which has a decimal in its expression.
System objects	<i>%S</i>	System bits, page 167	Stores system bit.
	<i>%SW</i>	System words, page 174	Stores system word.
	<i>%IWS</i>	Input channel status word, page 189	Contains diagnostic information concerning analog input channels.
	<i>%QWS</i>	Output channel status word, page 191	Contains diagnostic information concerning analog output channels.
I/O objects	<i>%I</i>	Input bits, page 153	Stores value of the digital input.
	<i>%Q</i>	Output bits, page 154	Stores value of the digital output.
	<i>%IW</i>	Input words, page 154	Stores value of the analog input.
	<i>%QW</i>	Output words, page 156	Stores value of the analog output.
	<i>%FC</i>	Fast counters	Execute fast counts of pulses from sensors, switches, and so on.
	<i>%HSC</i>	High speed counters	Execute fast counts of pulses from sensors, switches, and so on, that are connected to the fast inputs.
	<i>%PLS</i>	Pulse	Generates a square wave pulse signal on dedicated output channels.
	<i>%PWM</i>	Pulse width modulation	Generates a modulated wave signal on dedicated output channels with a variable duty cycle.
	<i>%PTO</i>	Pulse train output	Generates a pulse train output to control a linear single-axis stepper or servo drive in open loop mode.
<i>%FREQGEN</i>	Frequency Generator	Generates a square wave signal on a dedicated output channel with programmable frequency and duty cycle of 50%.	

Object Type	Object	Object Function	Description
Network objects	%QWE	Input assembly (EtherNet/IP), page 157	The values of EtherNet/IP Input assembly frames sent by the logic controller. NOTE: For more details about directionality, refer to Configuring EtherNet/IP, page 110.
	%IWE	Output assembly (EtherNet/IP), page 158	The values of EtherNet/IP Output assembly frames received by the logic controller. NOTE: For more details about directionality, refer to Configuring EtherNet/IP, page 110.
	%QWM	Input registers (Modbus TCP), page 159	The values of Modbus mapping table Input registers sent by the logic controller.
	%IWM	Output registers (Modbus TCP), page 160	The values of Modbus mapping table Output registers received by the logic controller.
	%IN	Digital inputs (IOScanner), page 161	The values of Modbus Serial or TCP IOScanner digital input bits.
	%QN	Digital outputs (IOScanner), page 162	The values of Modbus Serial or TCP IOScanner digital output bits.
	%IWN	Input registers (IOScanner), page 163	The values of Modbus Serial or TCP IOScanner digital input words.
	%QWN	Output registers (IOScanner), page 164	The values of Modbus Serial or TCP IOScanner digital output words.
	%IWNS	IOScanner network diagnostic codes, page 166	The values of Modbus Serial or TCP IOScanner network diagnostic bits.
Software objects	%TM	Timers	Specifies a time before triggering an action.
	%C	Counters	Provides up and down counting of actions.
	%MSG	Messages	Stores the status message at the communication port.
	%R	LIFO/FIFO registers	Stores memory up to 16 words of 16 bits each in 2 different ways, queue, and stacks.
	%DR	Drums	Operates on a principle similar to an electromechanical drum controller which changes step according to external events.
	%SBR	Shift bit registers	Provides a left or right shift of binary data bits (0 or 1).
	%SC	Step counters	Provides a series of steps to which actions can be assigned.
	SCH	Schedule blocks	Controls actions at a predefined month, day, and time.
	%RTC	RTC	Allows reading or writing the value of the Real Time Clock (RTC) on the logic controller.
	PID	PID	Provides a generic control loop feedback in which output is proportional, integral, and derivative of the input.
	%X	Grafcet steps	Bit objects associated with individual Grafcet (SFC) steps. Object is set to 1 when the corresponding step is active, and set to 0 when the step is deactivated.
Object Type	Object	Object Function	Description
PTO objects	Refer to Pulse Train Output.		
Drive objects	Refer to Drive Objects.		
Communication objects	%READ_VAR	Read Var	The %READ_VAR function block is used to read data from a remote device on Modbus SL or Modbus TCP.
	%WRITE_VAR	Write Var	The %WRITE_VAR function block is used to write data to an external device using the Modbus SL or Modbus TCP protocol.
	%WRITE_READ_VAR	Write Read Var	The %WRITE_READ_VAR function block is used to read and write data stored in internal memory words to an external device using the Modbus SL or Modbus TCP protocol.
	%SEND_RECV_MSG	Send Receive Message	The %SEND_RECV_MSG function block is used to send or receive data on a serial line configured for the ASCII protocol.
	%SEND_RECV_SMS	Send Receive SMS	The %SEND_RECV_SMS function block is used to send or receive SMS messages through a GSM modem connected to a serial line.

Object Type	Object	Object Function	Description
User-defined function and user-defined function block objects	<i>%RET0</i>	Return value	The return value of a user-defined function.
	<i>%PARAM</i>	Parameter	Parameters of a user-defined function or user-defined function block. The parameters are different for each object type.
	<i>%VAR</i>	Local variable	Local variables of a user-defined function or user-defined function block. The local variables are different for each object type.

Memory objects and software objects are generic objects used in EcoStruxure Machine Expert - Basic, whereas system objects and I/O objects are controller-specific. All controller-specific objects are discussed in the [Programming, page 152](#) section.

For programming details of memory objects, software objects, and communication objects, refer to the EcoStruxure Machine Expert - Basic Generic Functions Library Guide.

For programming details of PID, Drive, and PTO objects, refer to the Advanced Functions Library Guide.

For more information on user-defined functions and user-defined function blocks, refer to EcoStruxure Machine Expert - Basic Operating Guide (see EcoStruxure Machine Expert - Basic, Operating Guide).

Addressing I/O Objects

Addressing Examples

This table presents addressing examples for various object types:

Object Type	Syntax	Example	Description
Memory objects			
Memory bits	%M <i>i</i>	%M25	Internal memory bit 25.
Memory words	%MW <i>i</i>	%MW15	Internal memory word 15.
Memory double words	%MD <i>i</i>	%MD16	Internal memory double word 16.
Memory floating points	%MF <i>i</i>	%MF17	Internal memory floating point 17.
Constant words	%KW <i>i</i>	%KW26	Constant word 26.
Constant double words	%KD <i>i</i>	%KD27	Internal constant double word 27.
Constant floating points	%KF <i>i</i>	%KF28	Internal constant floating point 28.
System objects			
System bits	%S <i>i</i>	%S8	System bit 8.
System words	%SW <i>i</i>	%SW30	System word 30.
I/O objects			
Digital inputs	%I <i>y.z</i>	%I0.5	Digital input 5 on the controller (embedded I/O).
Digital outputs	%Q <i>y.z</i>	%Q3.4	Digital output 4 on the expansion module at address 3 (expansion module I/O).
Analog inputs	%IW <i>y.z</i>	%IW0.1	Analog input 1 on the controller (embedded I/O).
Analog outputs	%QW0. <i>m0n</i>	%QW0.100	Analog output 0 on the cartridge 1.
Fast counters	%FC <i>i</i>	%FC2	Fast counter 2 on the controller.
High speed counters	%HSC <i>i</i>	%HSC1	High speed counter 1 on the controller.
Pulse	%PLS <i>i</i>	%PLS0	Pulse output 0 on the controller.
Pulse width modulation	%PWM <i>i</i>	%PWM1	Pulse width modulation output 1 on the controller.
Pulse train output	%PTO <i>i</i>	%PTO1	Pulse train output 1 on the controller.
Frequency generator	%FREQGEN <i>i</i>	%FREQGEN1	Frequency generator 1 on the controller.
Network objects			
Input assembly (EtherNet/IP)	%QWE <i>i</i>	%QWE8	Input assembly instance 8.
Output assembly (EtherNet/IP)	%IWE <i>i</i>	%IWE6	Output assembly instance 6.
Input registers (Modbus TCP)	%QWM <i>i</i>	%QWM1	Input register instance 1.
Output registers (Modbus TCP)	%IWM <i>i</i>	%IWM0	Output register instance 0.
Digital inputs (IOScanner)	%IN <i>a.b.c</i>	%IN300.2.1	Modbus TCP IOScanner slave device 0 on ETH1, channel 2, digital input 1.
Digital outputs (IOScanner)	%QN <i>a.b.c</i>	%QN101.1.0	Modbus Serial IOScanner slave device 1 on SL1, channel 1, digital output 0.
Input registers (IOScanner)	%IWN <i>a.b.c</i>	%IWN302.3.0	Modbus TCP IOScanner slave device 2 on ETH1, channel 3, input register 0.
Output registers (IOScanner)	%QWN <i>a.b.c</i>	%QWN205.0.4	Modbus Serial IOScanner slave device 5 on SL2, channel 0, output register 4.

Object Type	Syntax	Example	Description
IOScanner network diagnostic codes	%IWNSa	%IWNS302	Status of Modbus TCP IOScanner slave device 2 on ETH1.
	%IWNSa.b	%IWNS205.3	Status of channel 3 of Modbus Serial IOScanner slave device 5 on serial line SL2
Software objects			
Timers	%TMi	%TM5	Timer instance 5.
Counters	%Ci	%C2	Counter instance 2.
Message	%MSGi	%MSG1	Program compilation status message 1.
LIFO/FIFO registers	%Ri	%R3	FIFO/LIFO registers instance 3.
Drums	%DRi	%DR6	Drum register 6 on the controller.
Shift bit registers	%SBRi	%SBR5	Shift bit register 5 on the controller.
Step counters	%SCi	%SC5	Step counter 5 on the controller.
Schedule blocks	SCH i	SCH 3	Schedule block 3 on the controller.
RTC	RTCi	RTC 1	Real-time clock (RTC) instance 1.
PID	PIDi	PID 7	PID feedback object 7 on the controller.
Grafcet Steps	Xi	X1	Grafcet step 1.
PTO objects			
MC_Power_PTO (motion function block)	%MC_POWER_PTOi	%MC_POWER_PTO1	MC_POWER_PTO function block instance 1.
MC_Reset_PTO (administrative function block)	%MC_RESET_PTOi	%MC_RESET_PTO0	MC_RESET_PTO function block instance 0.
Communication objects			
Read Var	%READ_VARi	%READ_VAR2	READ_VAR function block instance 2.
Write Var	%WRITE_VARi	%WRITE_VAR4	WRITE_VAR function block instance 4.
Write Read Var	%WRITE_READ_VARi	%WRITE_READ_VAR0	WRITE_READ_VAR function block instance 0.
Send Receive Message	%SEND_RECV_MSGi	%SEND_RECV_MSG6	SEND_RECV_MSG function block instance 6.
Send Receive SMS	%SEND_RECV_SMSi	%SEND_RECV_SMS0	SEND_RECV_SMS function block instance 0.
User-defined function and user-defined function block objects			
Return value	%RETi	%RET0	Return value of a user-defined function.
Parameters	%PARAMi	%PARAM0	Parameter of a user-defined function.
Local variables	%VARi	%VAR0	Local variables of a user-defined function.
<p>a: 100 + device number on SL1, 200 + device number on SL2, 300 + device number on ETH1.</p> <p>b: Channel number of the Modbus Serial IOScanner or Modbus TCP IOScanner device.</p> <p>c: Object instance identifier in the channel.</p> <p>i: Object instance identifier that indicates the instance of the object on the controller.</p> <p>m: Cartridge number on the controller.</p> <p>n: Channel number on the cartridge.</p> <p>y: Indicates the I/O type. It is 0 for the controller and 1, 2, and so on, for the expansion modules.</p> <p>z: Channel number on the controller or expansion module.</p>			

Maximum Number of Objects

Maximum Number of Objects Description

This table provides information about the maximum number of objects supported by the M221 Logic Controller:

Objects	M221 Logic Controller References			
	Modular References		Compact References	
	TM221M16R• TM221ME16R•	TM221M16T• TM221ME16T• TM221M32TK TM221ME32TK	TM221C••R TM221CE••R	TM221C••T TM221CE••T TM221C••U TM221CE••U
Memory objects				
%M ⁽¹⁾	512 1024	512 1024	512 1024	512 1024
%MW	8000	8000	8000	8000
%MD %MF	7999	7999	7999	7999
%KW	512	512	512	512
%KD %KF	511	511	511	511
System objects				
%S	160	160	160	160
%SW	234	234	234	234
%IWS	1 created automatically for each analog input			
%QWS	1 created automatically for each analog output			
I/O objects				
%I	8	8 (for TM221M16T• and TM221ME16T•)	9 (for TM221C16• and TM221CE16•)	9 (for TM221C16• and TM221CE16•)
		16 (for TM221M32TK and TM221ME32TK)	14 (for TM221C24• and TM221CE24•)	14 (for TM221C24• and TM221CE24•)
			24 (for TM221C40• and TM221CE40•)	24 (for TM221C40• and TM221CE40•)
%Q	8	8 (for TM221M16T• and TM221ME16T•)	7 (for TM221C16• and TM221CE16•)	7 (for TM221C16• and TM221CE16•)
		16 (for TM221M32TK and TM221ME32TK)	10 (for TM221C24• and TM221CE24•)	10 (for TM221C24• and TM221CE24•)
			16 (for TM221C40• and TM221CE40•)	16 (for TM221C40• and TM221CE40•)
%IW	2	2	2	2

Objects	M221 Logic Controller References			
	Modular References		Compact References	
	TM221M16R• TM221ME16R•	TM221M16T• TM221ME16T• TM221M32TK TM221ME32TK	TM221C••R TM221CE••R	TM221C••T TM221CE••T TM221C••U TM221CE••U
%QW	0	0	NOTE: Analog outputs are not built in with the controller. Use cartridges TMC2AQ2V and/or TMC2AQ2C to add analog outputs to your controller configuration.	
			2 (if 1 cartridge is used) 4 (if 2 cartridges are used with TM221C40R or TM221CE40R)	2 (if 1 cartridge is used) 4 (if 2 cartridges are used with TM221C40T or TM221CE40T or TM221C••U or TM221CE••U)
%FC	4	4	4	4
%HSC	Up to 4	Up to 4	Up to 4	Up to 4
%PLS %PWM %PTO %FREQGEN	0	2	0	2
Network objects				
%QWE	20 (for TM221ME16R•)	20 (for TM221ME16T• and TM221ME32TK)	20 (for TM221CE16•)	20 (for TM221CE16•)
%IWE	20 (for TM221ME16R•)	20 (for TM221ME16T• and TM221ME32TK)	20 (for TM221CE16•)	20 (for TM221CE16•)
%QWM	20 (for TM221ME16R•)	20 (for TM221ME16T• and TM221ME32TK)	20 (for TM221CE16•)	20 (for TM221CE16•)
%IWM	20 (for TM221ME16R•)	20 (for TM221ME16T• and TM221ME32TK)	20 (for TM221CE16•)	20 (for TM221CE16•)
%IN	128	128	128	128
%QN	128	128	128	128
%IWN	128 ⁽²⁾	128 ⁽²⁾	128 ⁽²⁾	128 ⁽²⁾
%QWN	128 ⁽²⁾	128 ⁽²⁾	128 ⁽²⁾	128 ⁽²⁾
%IWNS	1 for each configured Modbus Serial IOScanner or Modbus TCP IOScanner device, plus 1 for each channel			
%QWNS	1 for each configured Modbus Serial IOScanner or Modbus TCP IOScanner device, plus 1 for each channel			
Software objects				
%TM	255	255	255	255
%C	255	255	255	255
%MSG	2	2	1 (for TM221C••R)	1 (for TM221C••T and TM221C••U)
			2 (for TM221CE••R)	2 (for TM221CE••T and TM221CE••U)

Objects	M221 Logic Controller References			
	Modular References		Compact References	
	TM221M16R• TM221ME16R•	TM221M16T• TM221ME16T• TM221M32TK TM221ME32TK	TM221C••R TM221CE••R	TM221C••T TM221CE••T TM221C••U TM221CE••U
%R	4	4	4	4
%DR	8	8	8	8
%SBR	8	8	8	8
%SC	8	8	8	8
%SCH	16	16	16	16
%RTC	2	2	2	2
PID	14	14	14	14
Drive objects				
%DRV	16	16	16	16
Communication objects				
%READ_VAR	32 (if functional level ≥ 10.1) or 16 (if functional level < 10.1).			
%WRITE_VAR	32 (if functional level ≥ 10.1) or 16 (if functional level < 10.1).			
%WRITE_READ_VAR	32 (if functional level ≥ 10.1) or 16 (if functional level < 10.1).			
%SEND_RECV_MSG	16	16	16	16
%SEND_RECV_SMS	1	1	1	1
User-defined function objects				
%RET0	1 per user-defined function			
%PARAM	5 per user-defined function			
%VAR	48 (including any existing %PARAM)			
User-defined function block objects				
%Q_	32 (if functional level ≥ 10.0) or 8 (if functional level < 10.0).			
%I_	32 (if functional level ≥ 10.0) or 8 (if functional level < 10.0).			
%PARAM	48 (including any existing %VAR)			
%VAR	48 (including any existing %PARAM)			
<p>(1) The value 512 is for software version < 1.3.</p> <p>(2) If functional level < 6.0. If functional level ≥ 6.0, the maximum number of objects is 512.</p>				

Maximum Number of PTO Objects Description

This table provides information about the maximum number of PTO objects supported by the M221 Logic Controller:

Categories/Objects	M221 Logic Controller References		
	TM221M16R• TM221ME16R• TM221C•R TM221CE•R	TM221M16T• TM221ME16T• TM221M32TK TM221ME32TK TM221C•T TM221CE•T TM221C16U TM221CE16U TM221C24U TM221CE24U	TM221C40U TM221CE40U
Motion/Single-axis			
%MC_POWER_PTO	0	86	
%MC_MOVEVEL_PTO			
%MC_MOVEREL_PTO			
%MC_MOVEABS_PTO			
%MC_HOME_PTO			
%MC_SETPOS_PTO			
%MC_STOP_PTO			
%MC_HALT_PTO			
Motion/Motion Task			
%MC_MotionTask_PTO	0	2	4
Administrative			
%MC_READACTVEL_PTO	0	40	
%MC_READACTPOS_PTO			
%MC_READSTS_PTO			
%MC_READMOTIONSTATE_PTO			
%MC_READAXISERROR_PTO			
%MC_RESET_PTO			
%MC_TOUCHPROBE_PTO			
%MC_ABORTTRIGGER_PTO			
%MC_READPAR_PTO			
%MC_WRITEPAR_PTO			

Task Structure

Tasks and Scan Modes

Overview

The Modicon TM221M Logic Controller supports the following task types:

- Master task
- Periodic task
- Event task

The master tasks can be configured in either of the following scan modes:

- Freewheeling mode
- Periodic mode

For more information, refer to the Configuring Program Behavior and Tasks (see EcoStruxure Machine Expert - Basic, Operating Guide).

Tasks

Master tasks are triggered by continuous cyclic scanning or by the software timers by specifying the scan period 1...150 ms (default 100 ms) in the periodic mode.

Periodic tasks are triggered by software timers, so are configured by specifying the scan period 1...255 ms (default 255 ms) in the periodic mode.

Event tasks are triggered by the physical inputs or the HSC function blocks. These events are associated with embedded digital inputs (%I0.2...%I0.5) (rising, falling or both edges) or with the high speed counters (when the count reaches the high speed counter threshold). You can configure up to two events for each HSC function block, depending on the configuration.

You must configure one priority for each event task. The priority range is 0...7 and the priority 0 has the highest priority.

Scan Modes

The freewheeling mode is a continuous cyclic scanning mode. In this mode, a new scan starts immediately after the previous scan has completed.

This figure presents the relationship between master tasks and periodic tasks when the master task is in freewheeling mode:

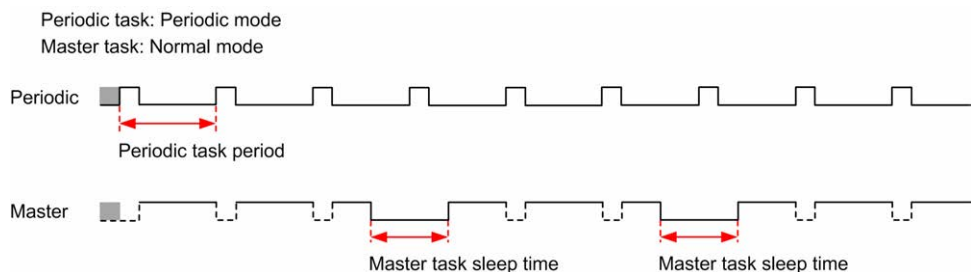

In freewheeling mode, the master task sleep time is at least 30% of the total cycle time with a minimum of 1 millisecond. This percentage may be higher depending on the user application (periodic task scan time, event task scan time, communication interaction, and so on).

In periodic mode, the logic controller waits until the configured scan time has elapsed before starting a new scan. Every scan is therefore the same duration.

This figure presents the relationship between master tasks and periodic tasks when the master task is in periodic mode:

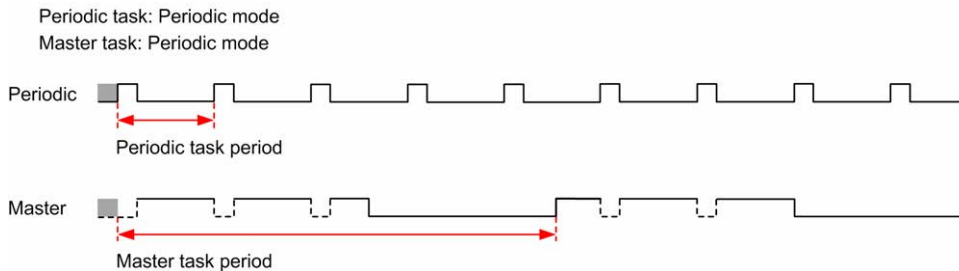

If the processor goes to the *HALTED* state when the master task is configured in freewheeling mode, verify whether the periodic task scan delay time is significant in comparison to the periodic task period. If so, try:

- reconfiguring the master freewheeling task as a cyclic task
- increasing the periodic task period.

Event priorities control the relationship between the event tasks, master tasks, and periodic tasks. The event task interrupts the master task and periodic task execution.

This figure presents the relationship between event tasks, master tasks, and periodic tasks in the periodic mode:

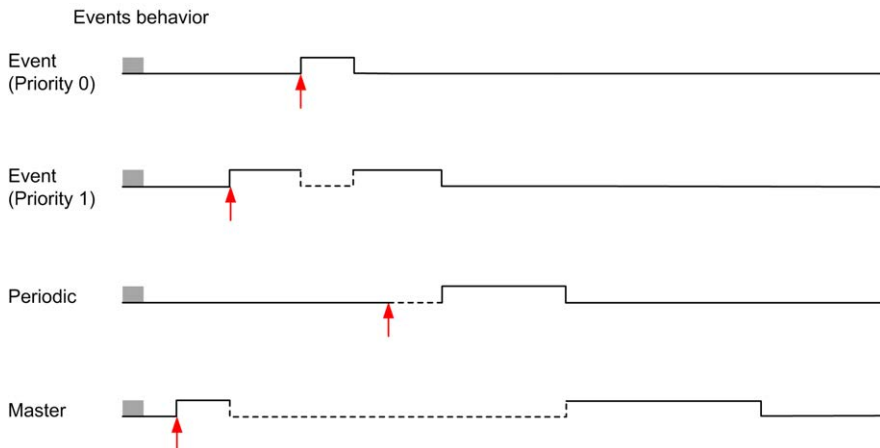

The event tasks are triggered by a hardware interruption that sends a task event to the event task.

Watchdog Timer

You can configure a specific application watchdog timer for the master task and periodic task. If the task execution time exceeds the configured watchdog timer period, the logic controller goes to the *HALTED* state.

A system watchdog timer verifies whether the program is using more than 80% of the processing capacity. In this case, the logic controller goes in the *HALTED* state.

Maximum Number of Tasks and Priorities

Description

This table summarizes the task types, available scan modes for each task, scan mode triggering conditions, operator configurable ranges, maximum number of each task, and their execution priorities:

Task Type	Scan Mode	Triggering Condition	Configurable Range	Maximum Number of Tasks	Priority
Master	Freewheeling	Normal	Not applicable	1	Lowest
	Periodic	Software timer	1...150 ms		
Periodic	Periodic	Software timer	1...255 ms	1	Higher than master task and lower than event tasks
Event	Periodic	Physical inputs	%I0.2...%I0.5	4	Highest
		%HSC function blocks	Up to 2 events per %HSC object	4	

Controller States and Behaviors

Introduction

This section provides you with information on controller states, state transitions, and behaviors in response to system events. It begins with a detailed controller state diagram and a description of each state. It then defines the relationship of output states to controller states before explaining the commands and events that result in state transitions. It concludes with information about persistent variables and the effect of EcoStruxure Machine Expert - Basic task programming options on the behavior of your system.

Controller States Diagram

Controller States Diagram

This figure describes the controller states:

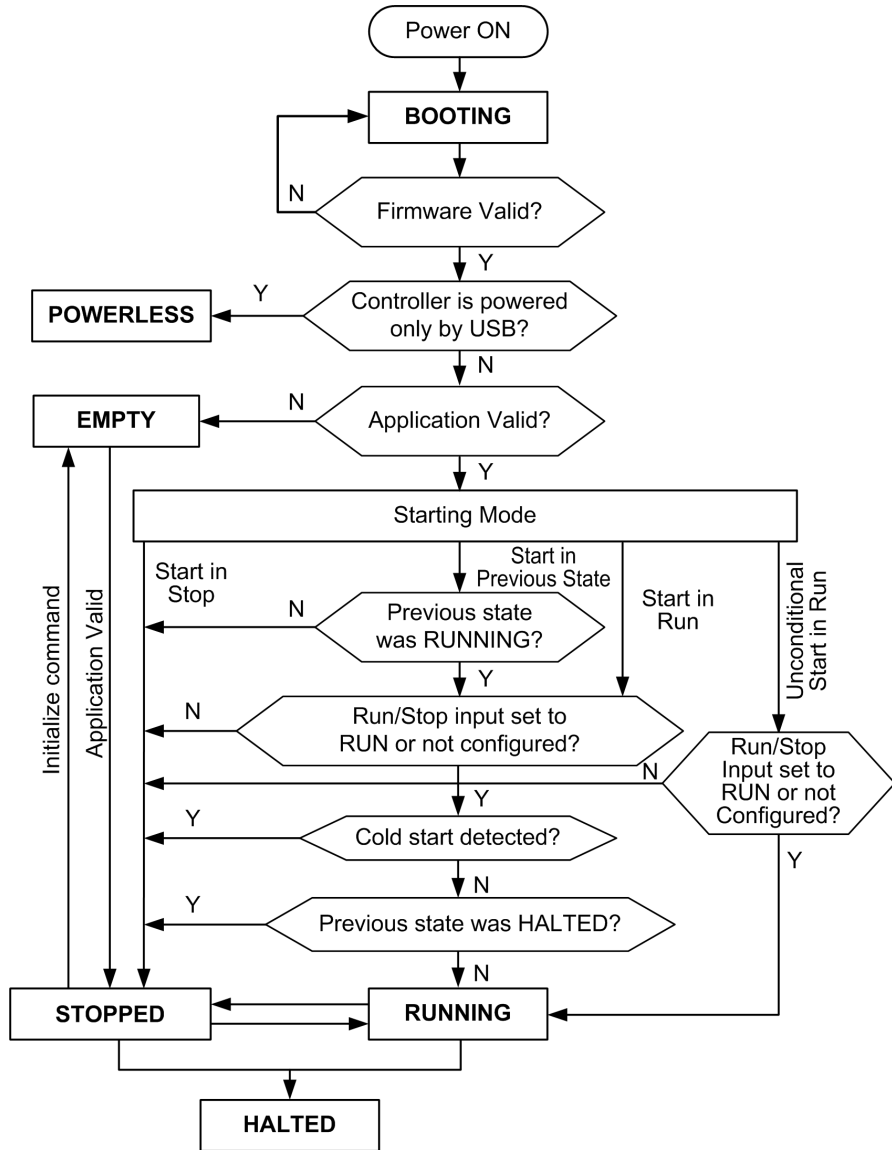

Controller States Description

Introduction

This section provides a detailed description of the controller states.

⚠ WARNING

UNINTENDED EQUIPMENT OPERATION

- Never assume that your controller is in a certain controller state before commanding a change of state, configuring your controller options, uploading a program, or modifying the physical configuration of the controller and its connected equipment.
- Before performing any of these operations, consider the effect on all connected equipment.
- Before acting on a controller, always positively confirm the controller state by viewing its LEDs, confirming the condition of the Run/Stop input, checking for the presence of output forcing, and reviewing the controller status information via EcoStruxure Machine Expert - Basic.

Failure to follow these instructions can result in death, serious injury, or equipment damage.

NOTE: The system word %SW6 indicates the logic controller state (*EMPTY*, *STOPPED*, *RUNNING*, *HALTED*, and *POWERLESS*).

When using the Start In Run feature, the controller will start executing program logic when power is applied to the equipment. It is essential to know in advance how automatic reactivation of the outputs will affect the process or machine being controlled. Configure the Run/Stop input to help control the Start In Run feature. In addition, the Run/Stop input is designed to give local control over remote RUN commands. If the possibility of a remote RUN command after the controller had been stopped locally by EcoStruxure Machine Expert - Basic would have unintended consequences, you must configure and wire the Run/Stop input to help control this situation.

⚠ WARNING

UNINTENDED MACHINE START-UP

- Confirm that the automatic reactivation of the outputs does not produce unintended consequences before using the Start In Run feature.
- Use the Run/Stop input to help control the Start In Run feature and to help prevent the unintentional start-up from a remote location.
- Verify the state of security of your machine or process environment before applying power to the Run/Stop input or before issuing a Run command from a remote location.

Failure to follow these instructions can result in death, serious injury, or equipment damage.

When using the Unconditional Start In Run feature, the controller will attempt to start executing program logic when power is applied to the equipment, independent of the reason the controller had previously stopped. This occurs even if there is no charge in the battery, or if the battery is not present. Therefore, the controller will start with all memory values re-initialized to zero or other predetermined default values. It is conceivable that if the controller attempts to restart, for example, after a short power outage, the values in memory at the time of the outage would be lost, and restarting the machine may have unintended consequences as there was no battery to maintain memory values. It is essential to know in advance how an unconditional start will affect the process or machine being controlled. Configure the Run/Stop input to help control the Unconditional Start In Run feature.

⚠ WARNING
<p>UNINTENDED MACHINE OPERATION</p> <ul style="list-style-type: none"> Conduct a thorough risk analysis to determine the effects, under all conditions, of configuring the controller with the Unconditional Start In Run feature. Use the Run/Stop input to help avoid an unwanted unconditional restart. <p>Failure to follow these instructions can result in death, serious injury, or equipment damage.</p>

For more information about the Unconditional Start In Run feature, refer to Application Behavior (see EcoStruxure Machine Expert - Basic, Operating Guide).

Controller States Table

This table provides detailed description of the controller operating states:

Controller State	Description	Communication	Application Execution	LED		
				PWR	RUN	ERR
<i>BOOTING</i>	<p>The logic controller does not have a valid firmware.</p> <p>The communication channels are enabled to allow updating of the runtime firmware.</p> <p>It is not possible to login with EcoStruxure Machine Expert - Basic.</p> <p>Outputs are set to initialization values, page 46.</p>	Restricted	No	On	Off	On
<i>EMPTY</i>	<p>This state indicates that there is not a valid application.</p> <p>It is possible to login with EcoStruxure Machine Expert - Basic (<i>download/animation table</i>).</p> <p>Inputs are forced to 0.</p> <p>Outputs are set to initialization values, page 46.</p>	Yes	No	On	Off	1 flash
<i>STOPPED</i>	<p>This state indicates that the logic controller has a valid application which is stopped.</p> <p>Inputs are read.</p> <p>Outputs are set to fallback values, page 47, or forced values, page 47 from EcoStruxure Machine Expert - Basic.</p> <p>Status alarm output is set to 0.</p>	Yes	No	On	Flashing	Off
<i>RUNNING</i>	<p>This state indicates that the logic controller is executing the application.</p> <p>Inputs are read by the application tasks.</p> <p>Outputs are written by the application tasks, or from EcoStruxure Machine Expert - Basic in online mode (<i>animation table, output forcing, page 47</i>).</p> <p>Status alarm output is set to 1.</p>	Yes	Yes	On	On	Off

Controller State	Description	Communication	Application Execution	LED		
				PWR	RUN	ERR
<i>HALTED</i>	<p>This state indicates that the application is stopped because an application or system watchdog timeout error has been detected., page 148</p> <p>Objects retain their values, allowing analysis of the cause of the detected error. The tasks are stopped at the last instruction.</p> <p>The communication capabilities are the same as in <i>STOPPED</i> state.</p> <p>Inputs are not read, and keep their last values.</p> <p>Outputs are set to fallback values, page 47.</p> <p>Status alarm output is set to 0.</p>	Yes	No	On	Flashing	On
<i>POWERLESS</i>	<p>This state indicates that the logic controller is powered only by the USB cable. This mode can be used to update the firmware (by USB) or to download/upload the user application (by USB).</p> <p>To change the state of the logic controller, connect the main power so that the logic controller boots and reloads the installed components.</p> <p>It is possible to login with EcoStruxure Machine Expert - Basic (<i>download/upload/animation table</i>).</p> <p>Inputs are forced to 0.</p> <p>Outputs are set to initialization values, page 46.</p>	Yes (only USB)	No	Off	Flashing	Off

NOTE: The system word %SW6 indicates the logic controller state (*EMPTY*, *STOPPED*, *RUNNING*, *HALTED*, and *POWERLESS*).

Controller State Transitions

Boot Controller

Effect: Command a reboot of the logic controller. For details about power-on sequence, refer to the controller states diagram, page 38.

Methods:

- Power cycle
- Reboot by script
 - The script on an SD card can issue a REBOOT as its last command.

Application Download

Effect: Download the application into the logic controller memory.

Optionally, select the **Reset Memories** option to reset to 0 (default choice) or retain the present value of all memory words and bits on application download (see EcoStruxure Machine Expert - Basic, Operating Guide).

Methods:

- EcoStruxure Machine Expert - Basic online button:
 - Select the **PC to controller (download)** command.

Effect: Erase the application in the logic controller and set the logic controller in *EMPTY* state. Download the application into the logic controller memory. If download is successful, a Cold Start is done and the logic controller is set in *STOPPED* state.
- Application file transfer by SD card:
 - Effect: At the next reboot, erase the application in the logic controller and download the application files from the SD card to the controller memory. If download is successful, a Cold Start is done and the controller is set in *STOPPED* state.

Initialize Controller

Effect: Set the controller in *EMPTY* state, and then, after a Cold Start, in *STOPPED* state.

Methods:

- EcoStruxure Machine Expert - Basic online button:
 - Select the **Initialize controller** command.
- Remote Graphic Display.

RUN Controller

Effect: Command a transition to the *RUNNING* controller state.

Methods:

- Run/Stop (see Modicon M221 Logic Controller, Hardware Guide) switch on front face:
 - It commands a transition to *RUNNING* state on rising edge.
- Run/Stop (see Modicon M221 Logic Controller, Hardware Guide) input:
 - The input must be configured in the application (Configuring Digital Inputs, page 63).
 - It commands a transition to *RUNNING* state on rising edge.
- EcoStruxure Machine Expert - Basic online button:
 - Select the **Run Controller** command.
- Application starting mode (see EcoStruxure Machine Expert - Basic, Operating Guide) setting:
 - **Start in Run, Start in Previous State, or Unconditional Start in Run**
- Remote Graphic Display.

STOP Controller

Effect: Command a transition to the *STOPPED* state.

Methods:

- Run/Stop (see Modicon M221 Logic Controller, Hardware Guide) switch on front face:
 - It forces a transition to *STOPPED* state on low level.
- Run/Stop (see Modicon M221 Logic Controller, Hardware Guide) input:
 - The input must be configured in the application (Configuring Digital Inputs, page 63).
 - It forces a transition to *STOPPED* state on low level.
- EcoStruxure Machine Expert - Basic online button:
 - Select the **Stop Controller** command.
- Application starting mode (see EcoStruxure Machine Expert - Basic, Operating Guide) setting:
 - **Start in Stop** or **Start in Previous State**.
- **Download** command:
 - It needs the controller to be set in *STOPPED* state (after the download the controller is in *STOPPED* state).
- Remote Graphic Display.

Error Detected (Transition to *HALTED* State)

Effect: Command a transition to the *HALTED* state.

Reasons for switching to HALTED state:

- Application Watchdog timeout (configured by the user) (see EcoStruxure Machine Expert - Basic, Operating Guide)
- System Watchdog timeout (system overrun, over 80% of the processing capacity is used), page 36

Cold Start

Cold Start is defined to be a power-up with all data initialized to its default values, and program started from the beginning with program variables cleared. Software and hardware settings are initialized.

Cold Start occurs for the following reasons:

- Boot controller without validated application online modification.
- Apply power to a logic controller without a charged backup battery.
- Download application
- Initialize logic controller

Effects of the Cold Start:

- Initialize the function blocks.
- Clear the user memory.
- Put system objects %S and system words %SW to their initial values.
- Reload parameters from post configuration (changes in the post configuration are applied).
- Restore application from non-volatile memory (unsaved online changes are lost).
- Restart the internal components of the controller.

Warm Start

The Warm Start resumes running the program, in its previous operating state, with the counters, function blocks, and system words and bits maintained.

Persistent Variables

Automatic Save on Power Outage

The controller automatically saves the first 50 memory words (%MW0 to %MW49) in the non-volatile memory following any interruption of power. The data is restored to the memory word region during the initialization, even if the controller performs a cold start due to a missing or depleted battery.

These automatically saved persistent variables are reinitialized:

- After each new download, if the **Reset Memories** checkbox is selected in download settings (see EcoStruxure Machine Expert - Basic, Operating Guide).
- Following an initialization command.
- On system bit %S0 activation (refer to System Bits, page 167).

Save by User Request

You can save memory words in the non-volatile memory or in the SD card. To perform the save operation:

1. Select the destination with %S90 (refer to System Bits, page 167):
 - Set to 0: non-volatile memory (default)
 - Set to 1: SD card
2. Set the number of memory words to be saved in the system word %SW148 (refer to System Words, page 174).
3. Set the system bit %S93 to 1 (refer to System Bits, page 167).

When the save operation is finished:

- The system bit %S93 is reset to 0.
- The system bit %S92 is set to 1, indicating that memory words have been successfully saved in non-volatile memory (%S90 set to 0).
- The system word %SW147 indicates the SD card operation result (%S90 set to 1).

NOTE: You can initiate a memory save while the logic controller is in the *RUNNING* state. However, depending on the number of memory variables you specify, the save operation may not be accomplished within a single logic scan cycle. As a consequence, the memory values may not necessarily be consistent because the value of the memory variables can change from one scan to another. If you wish to have a consistent set of values for the variables, consider first putting the logic controller into the *STOPPED* state.

Restore by User Request

You can restore the previously saved memory words. To perform the restore operation:

1. Set the system bit %S92 to 1.
The non-volatile memory operation has no effect if %S92 is 0 (no values were previously saved).
2. Select the source with %S90 (refer to System Bits, page 167):
 - Set to 0: non-volatile memory (default)
 - Set to 1: SD card
3. To restore from the non-volatile memory, set the number of memory words in the system word %SW148 (refer to System Words, page 174). When restoring from SD card, the complete `MemoryVariables.csv` file is processed.
4. Set the system bit %S94 to 1 (refer to System Bits, page 167).

When the restore operation is finished:

- The system bit %S94 is reset to 0 by the system.
- The system word %SW148 is updated with the number of objects restored (for example if you specify 100 words to restore and only 50 had previously been saved, the value of %SW148 will be 50).
- The system word %SW147 indicates the SD card operation result (%S90 set to 1).

Delete by User Request

You can delete the previously saved memory words on the non-volatile memory. To perform the delete operation:

- Set the system bit %S91 to 1 (refer to System Bits, page 167).
- When the delete operation is finished, the system bits %S91 and %S92 and the system word %SW148 are reset to 0 by the logic controller.

This operation does not erase the variables in RAM memory.

NOTE: It is not possible to delete only selected variables; the entire set of saved variables is deleted (meaning %SW148 has no impact on the erase operation, the erase operation is carried out regardless of the value of %SW148).

Output Behavior

Introduction

The controller defines output behavior in response to commands and system events in a way that allows for greater flexibility. An understanding of this behavior is necessary before discussing the commands and events that affect controller states.

The possible output behaviors and the controller states to which they apply are:

- Managed by application
- Initialization values
- Fallback behavior (see EcoStruxure Machine Expert - Basic, Operating Guide)
 - Fallback values
 - Maintain values
- Output forcing

Managed by Application

Your application manages outputs normally. This applies in the *RUNNING* state.

Hardware Initialization Values

This output state applies in the *BOOTING*, *EMPTY*, and *POWERLESS* states.

In the initialization state, the outputs assume the following values:

- For embedded outputs:
 - Fast source transistor output: 0 Vdc
 - Fast sink transistor output: 24 Vdc
 - Regular source transistor output: 0 Vdc
 - Regular sink transistor output: 24 Vdc
 - Relay output: Open
- For expansion module outputs:
 - Regular source transistor output: 0 Vdc
 - Regular sink transistor output: 24 Vdc
 - Relay output: Open

Software Initialization Values

This output state applies when downloading or when resetting the application. It applies at the end of the download or at the end of a warm start or cold start.

Input objects (*%I* and *%IW*), network objects (*%QWE* and *%QWM*), and Modbus Serial IOScanner input objects (*%IN* and *%IWN*) are set to 0. Output objects (*%Q* and *%QW*), network objects (*%IWE* and *%IWM*), and Modbus Serial IOScanner output objects (*%QN* and *%QWN*) are set according to the selected fallback behavior.

Fallback Management

The objective of the fallback behavior is to control the outputs when the controller leaves the *RUNNING* state.

Fallback values are applied on the transition from *RUNNING* to *STOPPED* or *HALTED* states, except for special cases described below.

Fallback Behavior Configuration

Fallback behavior is configured on the **Programming** tab, **Tasks > Behavior** window:

- When **Fallback values** is selected, on a fallback occurrence, output values take the values configured in **Fallback value**.
- When **Maintain values** is selected, outputs keep their values on a fallback occurrence, except for outputs configured in pulse generator (PWM, PLS, PTO, FREQGEN) or reflex functions.

Fallback Execution

On a fallback occurrence:

- If **Fallback values** is selected, the outputs take the values configured in **Fallback value**.
- If **Maintain values** is selected, the outputs keep their values.

Special cases:

- Alarm output, PTO, and FREQGEN: The fallback is never applied. Their fallback values are forced to 0.
- PLS, PWM and reflex outputs:
 - If **Fallback values** is selected, the outputs take the values configured in **Fallback value**.
 - If **Maintain values** is selected, the outputs are set to 0.

NOTE:

- After a download, the outputs are set to their fallback values.
- In *EMPTY* state, the outputs are set to 0.
- As the data image reflects the physical values, fallback values are also applied to the data image. However, using system bit %S9 to apply fallback values does not modify the values of the data image.

Fallback Values

This output state applies in the *STOPPED* and *HALTED* states.

During fallback, the outputs assume the following values:

- For embedded outputs:
 - Fast transistor output: according to fallback setting
 - Regular transistor output: according to fallback setting
 - Relay output: according to fallback setting
 - Expert I/O functions (HSC, PLS, PWM, PTO, and FREQGEN):
 - Source output: 0 Vdc
 - Sink output: 24 Vdc
- For expansion module outputs:
 - Regular transistor output: according to fallback setting
 - Relay output: according to fallback setting

NOTE: An exception to the application of fallback values is in the case of an I/O expansion bus error. For more information, refer to *I/O Configuration General Description*, page 86.

Output Forcing

The controller allows you to force the state of selected outputs to a defined value for the purposes of system testing, commissioning, and maintenance.

You can force the value of an output while your controller is connected to EcoStruxure Machine Expert - Basic or with a TMH2GDB Remote Graphic Display (see Modicon TMH2GDB, Remote Graphic Display, User Guide).

To do so, either use the **Force** command in an animation table, or force the value using the F0 or F1 buttons in the Ladder editor.

Output forcing overrides all other commands to an output irrespective of the task logic that is being executed.

The forcing is not released by any online change nor logout of EcoStruxure Machine Expert - Basic.

The forcing is automatically released by Cold Start, page 43 and Download application, page 42 command.

The forcing does not apply for expert I/O functions (HSC, PLS, PWM, PTO, and FREQGEN).

⚠ WARNING

UNINTENDED EQUIPMENT OPERATION

- You must have a thorough understanding of how forcing will affect the outputs relative to the tasks being executed.
- Do not attempt to force I/O that is contained in tasks that you are not certain will be executed in a timely manner, unless your intent is for the forcing to take affect at the next execution of the task whenever that may be.
- If you force an output and there is no apparent affect on the physical output, do not exit EcoStruxure Machine Expert - Basic without removing the forcing.

Failure to follow these instructions can result in death, serious injury, or equipment damage.

Output Rearming

In the case of a short-circuit or current overload, the common group of outputs automatically enters into thermal protection mode (all outputs in the group are set to 0), and are then periodically rearmed (each second) to test the connection state. However, you must be aware of the effect of this rearming on the machine or process being controlled.

NOTE: The output rearming does not apply to sink outputs.

⚠ WARNING

UNINTENDED MACHINE START-UP

Inhibit the automatic rearming of outputs if this feature is an undesirable behavior for your machine or process.

Failure to follow these instructions can result in death, serious injury, or equipment damage.

NOTE: Only the short-circuit between an output set to `TRUE` and 0 V is detected. The short-circuit between an output set to `FALSE` and 24 V is not detected.

If necessary, you can use system bits and words to both detect that a short circuit or overload has occurred and on which cluster of outputs it has occurred. System bit `%S10` can be used to detect within your program that an output error has occurred. You can then use the system word `%SW139` to determine programmatically in which cluster of outputs a short circuit or overload has occurred.

The automatic rearming feature can be disabled by setting the system bit `%S49` to 0 (`%S49` is set to 0 by default).

Post Configuration

Introduction

This section describes how to manage and configure the post configuration file of the Modicon M221 Logic Controller.

Post Configuration

Introduction

Post configuration is an option that allows you to modify some parameters of the application without changing the application. Post configuration parameters are defined in a file called **Machine.cfg**, which is stored in the controller.

By default, all communication parameters are set in the configuration of the application. However, under certain conditions, some or all of these parameters can be modified automatically via the mechanism Post Configuration. One or more communication parameters can be specified in the post configuration file, and those parameters can override the parameters specified by the configuration. For example, one parameter may be stored in the post configuration file to change the Ethernet IP address of the controller while leaving the other Ethernet parameters, such as the gateway address, unchanged.

Parameters

The post configuration file allows you to modify network parameters.

Ethernet parameters:

- Address configuration mode
- IP address
- Subnet mask
- Gateway address
- Device name

Serial line parameters, for each serial line in the application (embedded port or TMC2SL1 cartridge):

- Physical medium
- Baud rate
- Parity
- Data bits
- Stop bit
- Modbus address
- Polarization (for RS-485)

Operating Mode

The post configuration file is read and applied:

- after a Warm Start, page 44
- after a Cold Start, page 43
- after a reboot, page 41
- after an application download, page 42
- after an Ethernet reconfiguration caused by an Ethernet cable reconnection (exclusively for the Ethernet part of the post configuration file, page 95)

For further details on controller states and transitions, refer to Controller States and Behaviors, page 37.

Post Configuration File Management

Introduction

The post configuration file can be transferred, modified, or deleted with an SD card. Refer to [Post Configuration Management](#), page 146.

NOTE: A post configuration file example is available in the directory `Firmwares & PostConfiguration\PostConfiguration\add_change\usr\cfg` of the EcoStruxure Machine Expert - Basic installation directory.

Post Configuration File Format

A valid configuration must use the following format:

- The character '#' means beginning of comment, everything after this sign until the end of the line is ignored. Comments are not saved in the post configuration area of the M221 Logic Controller.
- Rule is `channel.parameter=value` (no space around the '=' sign).
- Channel and parameter are case-sensitive.
- Allowed channel, parameter, and values are in the following table.

Channel	Parameter	Description	Value
ETH	IPMODE	Address configuration mode	0 = Fixed 1 = BOOTP 2 = DHCP
	IP	IP address	Dotted decimal string
	MASK	Subnet mask	Dotted decimal string
	GATEWAY	Gateway address	Dotted decimal string
	NETWORKNAME	Device name on the network	ASCII string (maximum 16 characters)
SL1 SL2	HW	Physical medium	0 = RS-232 1 = RS-485
	BAUDS	Data transmission rate	1200, 2400, 4800, 9600, 19200, 38400, 57600 or 115200
	PARITY	Parity for error detection	0 = None 1 = Odd 2 = Even
	DATAFORMAT	Data format	7 or 8
	STOPBIT	Stop bit	1 or 2
	MODBUSADDR	Modbus address	1...247
	POLARIZATION	Polarization (for cartridges only)	0 = No 1 = Yes

NOTE: When using a post configuration file for Ethernet configuration, it is not mandatory to specify all the parameters:

- If the M221 Logic Controller is configured (by the user application) in DHCP or BOOTP mode, the network parameters IP (IP address), MASK (subnet mask) and GATEWAY (gateway address) are not configured in the file.
- If a parameter is not configured in the post configuration file, the M221 Logic Controller uses the value configured in the user application (see Ethernet configuration, page 95).
- If the M221 Logic Controller is configured in DHCP or BOOTP mode by the user application and if fixed IP mode (IPMODE=0) is configured in the post configuration file, configure the network parameters (IP (IP address), MASK (subnet mask) and GATEWAY (gateway address)) as they are not configured by the user application. Otherwise, the M221 Logic Controller starts with the default Ethernet configuration.

Post Configuration File Transfer

After creating and modifying your post configuration file, it must be transferred to the logic controller. The transfer is performed by copying the post configuration file to an SD card with a script.

Refer to [Adding or Changing a Post Configuration](#), page 147.

Modifying a Post Configuration File

Use a text editor to modify the post configuration file on the PC.

NOTE: Do not change the text file encoding. The default encoding is ANSI.

NOTE: The Ethernet parameters of the post configuration file can be modified with EcoStruxure Machine Expert - Basic. For more information, refer to [Connecting to a Logic Controller](#) (see EcoStruxure Machine Expert - Basic, Operating Guide).

Deleting the Post Configuration File

Refer to [Removing a Post Configuration File](#), page 148.

NOTE: The parameters defined in the application will be used instead of the corresponding parameters defined in the post configuration file.

Configuring the M221 Logic Controller

What's in This Part

How to Configure a Controller	53
Embedded Input/Output Configuration	63
I/O Bus Configuration	86
Embedded Communication Configuration	95
SD Card	138

Overview

This part provides information about how to configure the M221 Logic Controller references.

How to Configure a Controller

What's in This Chapter

Building a Configuration.....	53
Optional I/O Expansion Modules	57
Configuring the M221 Logic Controller	61
Updating Firmware using Executive Loader Wizard	62

Overview

This chapter describes how to build a configuration in EcoStruxure Machine Expert - Basic and configure the M221 Logic Controller.

Building a Configuration

Introduction

Configure a controller by building a configuration in EcoStruxure Machine Expert - Basic. To build a configuration, first create a new project or open an existing project.

Refer to **EcoStruxure Machine Expert - Basic** Operating Guide for information on how to:

- create or open an existing project
- replace the default logic controller
- add an expansion module to the logic controller
- add a cartridge to the logic controller
- save the project.

Some general information about the EcoStruxure Machine Expert - Basic user interface is provided below.

EcoStruxure Machine Expert - Basic Window

Once you have selected a project to work with, EcoStruxure Machine Expert - Basic displays the main window.

At the top of the main window, a toolbar (see EcoStruxure Machine Expert - Basic, Operating Guide) contains icons that allow you to perform common tasks, including opening the **Start Menu**.

Next to the toolbar, the status bar (see EcoStruxure Machine Expert - Basic, Operating Guide) displays informational messages about the state of the connection to the logic controller.

Below the toolbar and the status bar, the main window is divided into a number of *modules*. Each module controls a different stage of the development cycle, and is accessible by clicking the module tab.

This figure presents the toolbar, status bar, and the module tabs in the main window:

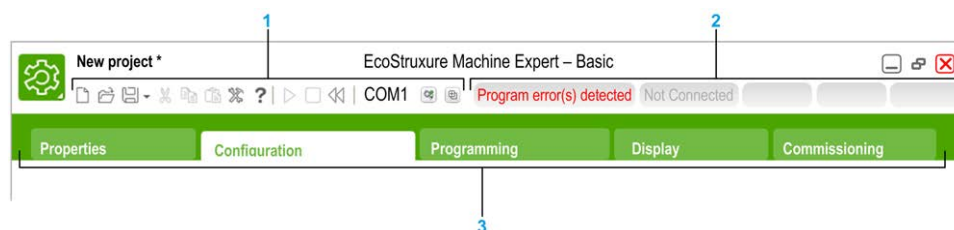

1 Toolbar

2 Status bar

3 Tabs

Item	Description
Toolbar	Provides easy access to commonly used functions. For more information, refer to the Toolbar (see EcoStruxure Machine Expert - Basic, Operating Guide).
Status bar	Displays status and information messages on the system status. For more information, refer to the Status bar (see EcoStruxure Machine Expert - Basic, Operating Guide).
Tabs	To develop an application, work your way through the module tabs from left to right: <ul style="list-style-type: none"> • Properties Set up the project properties. • Configuration Replicate and configure the hardware configuration of the logic controller and associated expansion modules. • Programming Develop the program in one of the supported programming languages. • Display Build an operator interface for a Remote Graphic Display device. Refer to the TMH2GDB Remote Graphic Display User Guide for details. • Commissioning Manage the connection between EcoStruxure Machine Expert - Basic and the logic controller, upload/download applications, test, and commission the application.

Hardware Tree

The hardware tree is displayed on left-hand side in the **Configuration** window. It shows a structured view of the hardware configuration. When you add a controller, an expansion module, or a cartridge to the project, several nodes are automatically added to the hardware tree.

NOTE: The nodes in the hardware tree are specific to the controller and the hardware configuration. These nodes depend on the I/O functions that the controller, expansion modules, and cartridges provide.

This figure presents the hardware tree of the controller configuration:

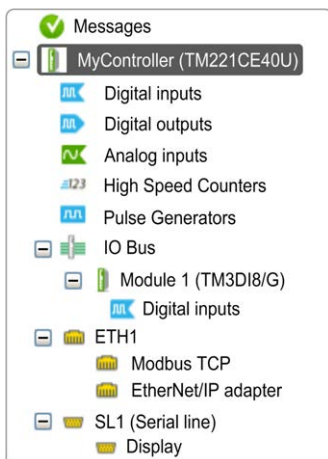

Item	Description
Digital inputs	Use to configure the embedded digital inputs of the logic controller.
Digital outputs	Use to configure the embedded digital outputs of the logic controller.
Analog inputs	Use to configure the embedded analog inputs of the logic controller.
High Speed Counters	Use to configure the embedded high speed counting functions (HSC).
Pulse Generators	Use to configure the embedded pulse generator functions (PLS/PWM/PTO/FREQGEN).
IO Bus	Use to configure the expansion modules and cartridges connected to the logic controller.
ETH1	Use to configure the embedded Ethernet communications.
Modbus TCP	Use to configure the Modbus TCP protocol for Ethernet communications.
EtherNet/IP adapter	Use to configure the EtherNet/IP adapter for Ethernet communications.
SLn (Serial line)	Use to configure the embedded serial line or the serial line added using a cartridge.
n Serial line number (1 or 2, controller-specific).	

Editor

The editor area is displayed in center of the **Configuration** window. It displays the graphical representation of hardware configuration of the devices. The hardware configuration in a project can be:

- only a controller
- a controller with cartridges
- a controller with expansion modules
- a controller with cartridges and expansion modules.

The editor area displays:

- a short description about the device when you click the device image or when you click the device node in the hardware tree.
- configuration properties of the item selected in the hardware tree.

If you add an expansion module to the configuration, the expansion module appears at the right-hand side of the controller or the previously added expansion module. Cartridges are added on the controller in the cartridge slot.

When configuring a controller, a cartridge, or an expansion module, the configuration properties of the node selected in the hardware tree are displayed below the graphical configuration. These properties allow you to configure the device.

This figure presents the configuration of a controller with an expansion module (the controller is selected):



Catalog

The catalog area is displayed on right-hand side in the **Configuration** window. It displays the complete range of the logic controllers, expansion modules, and cartridges that can be configured using EcoStruxure Machine Expert - Basic. It also provides a short description of the selected device.

You can drag-and-drop the objects from the catalog area to the editor area. You can also replace the existing controller by a different controller with simple drag-and-drop from the catalog.

This figure presents the catalog of the logic controllers and the expansion modules:

Reference	Type	Comm. Ports	Digital Input	Digital Output
TM221CE40R	Compact Vac	1 SL + 1 ETH	24	16 relays
TM221CE40T	Compact 24Vdc	1 SL + 1 ETH	24	16 transistors
TM221M16R/G	Modular 24Vdc	2 SL	8	8 relays
TM221M16T/G	Modular 24Vdc	2 SL	8	8 transistors
TM221M32TK	Modular 24Vdc	2 SL	16	16 transistors
TM221ME16R/G	Modular 24Vdc	1 SL + 1 ETH	8	8 relays
TM221ME16T/G	Modular 24Vdc	1 SL + 1 ETH	8	8 transistors
TM221ME32TK	Modular 24Vdc	1 SL + 1 ETH	16	16 transistors

Device description

TM221M16R (screw), TM221M16RG (spring)
 8 digital inputs, 8 relay outputs (2 A), 2 analog inputs, 2 serial line ports, 24 Vdc modular controller with removable terminal blocks.

5 V	24 V
520 mA	432 mA

Optional I/O Expansion Modules

Presentation

I/O expansion modules can be marked as optional in the configuration. The **Optional module** feature provides a more flexible configuration by the acceptance of the definition of modules that are not physically attached to the logic controller. Therefore, a single application can support multiple physical configurations of I/O expansion modules, allowing a greater degree of scalability without the necessity of maintaining multiple application files for the same application.

Without the **Optional module** feature, when the logic controller starts up the I/O expansion bus (following a power cycle, application download or initialization command), it compares the configuration defined in the application with the physical I/O modules attached to the I/O bus. Among other diagnostics made, if the logic controller determines that there are I/O modules defined in the configuration that are not physically present on the I/O bus, an error is detected and the I/O bus does not start.

With the **Optional module** feature, the logic controller ignores the absent I/O expansion modules that you have marked as optional, which then allows the logic controller to start the I/O expansion bus.

The logic controller starts the I/O expansion bus at configuration time (following a power cycle, application download, or initialization command) even if optional expansion modules are not physically connected to the logic controller.

The following module types can be marked as optional:

- TM3 I/O expansion modules
- TM2 I/O expansion modules

NOTE: TM3 Transmitter/Receiver modules (TM3XTRA1 and TM3XREC1) and TMC2 cartridges cannot be marked as optional.

The application must be configured with a functional level (see EcoStruxure Machine Expert - Basic, Operating Guide) of at least **Level 3.2** for modules marked as optional to be recognized as such by the logic controller.

You must be fully aware of the implications and impacts of marking I/O modules as optional in your application, both when those modules are physically absent and present when running your machine or process. Be sure to include this feature in your risk analysis.

⚠ WARNING

UNINTENDED EQUIPMENT OPERATION

Include in your risk analysis each of the variations of I/O configurations that can be realized marking I/O expansion modules as optional, and in particular the establishment of TM3 Safety modules (TM3S...) as optional I/O modules, and make a determination whether it is acceptable as it relates to your application.

Failure to follow these instructions can result in death, serious injury, or equipment damage.

Marking an I/O Expansion Module as Optional in Offline Mode

To add a module and mark it as optional in the configuration:

Step	Action
1	Drag-and-drop the I/O expansion module from the catalog to the editor.
2	In the Device information area, select the Optional module check box.

To mark an existing I/O expansion module as optional in the configuration:

Step	Action
1	Select the I/O expansion module in the editor.
2	In the Device information area, select the Optional module check box.

Optional I/O Expansion Modules in Online Mode

EcoStruxure Machine Expert - Basic operates in online mode when a physical connection to a logic controller has been established.

When in EcoStruxure Machine Expert - Basic online mode, the modification of the **Optional module** feature is disabled. You can visualize the downloaded configuration in the application:

- An I/O expansion module represented in yellow is marked as optional and not physically connected to the logic controller at start-up. An information message to that effect is displayed in the **Device information** area.
- An I/O expansion module represented in red is not marked as optional and not detected at start-up. An information message to that effect is displayed in the **Device information** area.

The selection of the **Optional module** feature is used by the logic controller to start the I/O bus. The following system words are updated to indicate the status of the physical I/O bus configuration:

System Word	Comment
%SW118 Logic controller status word	<p>Bits 13 and 14 are pertinent to the I/O module status relative to the I/O bus.</p> <p>Bit 13, if FALSE, indicates that there are mandatory modules as defined by the I/O expansion bus configuration that are absent or otherwise inoperative when the logic controller attempts to start the I/O expansion bus. In this case, the I/O bus does not start.</p> <p>Bit 14, if FALSE, indicates that one or more modules have ceased communication with the logic controller after the I/O expansion bus is started. This is the case whether an I/O expansion module is defined as mandatory or as an optional module but present at start-up.</p>
%SW119 I/O expansion module configuration	<p>Each bit, starting with bit 1 (bit 0 is reserved), is dedicated to a configured I/O expansion module and indicates whether the module is optional (TRUE) or mandatory (FALSE) when the controller attempts to start the I/O bus.</p>
%SW120 I/O expansion module status	<p>Each bit, starting with bit 1 (bit 0 is reserved), is dedicated to a configured I/O expansion module and indicates the status of the module.</p> <p>When the logic controller attempts to start the I/O bus, if the value of %SW120 is non-zero (indicating that an error is detected for at least one of the modules), the I/O expansion bus does not start unless the corresponding bit in %SW119 is set to TRUE (indicating the module is marked as an optional module).</p> <p>When the I/O bus is started, if the value of %SW120 is modified by the system, it indicates that an error is detected on one or more I/O expansion modules (regardless of the Optional module feature).</p>

For more information, refer to System Words, page 174.

Selecting the Functional Mode of an I/O Expansion Module in Offline Mode

The **Functional Mode** is only available on the digital expansion modules with firmware version ≥ 28 (SV ≥ 2.0), except TM3DI8A.

To select the module **Functional Mode** in the configuration:

Step	Action
1	Select the I/O expansion module in the editor.
2	<p>In the Device information area, select the Functional Mode:</p> <ul style="list-style-type: none"> • Normal (default value) • Latch, Filter, Fallback <p>NOTE: In EcoStruxure Machine Expert - Basic online mode, the modification of the Functional Mode is disabled.</p>

Internal ID Codes

Logic controllers identify expansion modules by a simple internal ID code. This ID code is not specific to each reference, but identifies the structure of the expansion module. Therefore, different references can share the same ID code.

If you declare two modules with the same internal ID code next to each other in the configuration and both are declared as optional, a message appears at the bottom of the **Configuration** window. There must be at least one non-optional module between two optional modules.

This table shows the internal ID codes of expansion modules:

Modules sharing the same internal ID code	ID code
TM2DDI16DT, TM2DDI16DK	0
TM2DRA16RT, TM2DDO16UK, TM2DDO16TK	1
TM2DDI8DT, TM2DAI8DT	4
TM2DRA8RT, TM2DDO8UT, TM2DDO8TT	5
TM2DDO32TK, TM2DDO32UK	3
TM2DMM24DRF, TM2DDI32DK	2
TM2DMM8DRT	6
TM2ALM3LT, TM2AMI2HT, TM2AMI2LT, TM2AMI4LT, TM2AMI8HT, TM2AMM3HT, TM2AMM6HT, TM2AMO1HT, TM2ARI8HT, TM2ARI8LRJ, TM2ARI8LT, TM2AVO2HT	96
TM3DI16, TM3DI16G, TM3DI16K	128
TM3DI8, TM3DI8G, TM3DI8A	132
TM3DQ16R, TM3DQ16RG, TM3DQ16T, TM3DQ16TG, TM3DQ16TK, TM3DQ16U, TM3DQ16UG, TM3DQ16UK	129
TM3DQ32TK, TM3DQ32UK	131
TM3DQ8R, TM3DQ8RG, TM3DQ8T, TM3DQ8TG, TM3DQ8U, TM3DQ8UG	133
TM3DM8R, TM3DM8RG	134
TM3DM24R, TM3DM24RG	135
TM3SAK6R, TM3SAK6RG	144
TM3SAF5R, TM3SAF5RG	145
TM3SAC5R, TM3SAC5RG	146
TM3SAFL5R, TM3SAFL5RG	147
TM3AI2H, TM3AI2HG	192
TM3AI4, TM3AI4G	193
TM3AI8, TM3AI8G	194
TM3AQ2, TM3AQ2G	195
TM3AQ4, TM3AQ4G	196
TM3AM6, TM3AM6G	197
TM3TM3, TM3TM3G	198
TM3TI4, TM3TI4G	199
TM3TI4D, TM3TI4DG	203
TM3TI8T, TM3TI8TG	200
TM3DI32K	130
TM3XTYS4	136

Configuring the M221 Logic Controller

Controller Configuration

Controller configuration depends on the number and type of embedded input/outputs, I/O objects, and communication ports.

Use the **Configuration** tab to configure the properties of your controller and the expansion modules. Select a node in the hardware tree to configure the properties of the controller.

This table shows the available configurations of the M221 Logic Controller:

Reference	Digital Input	Digital Output	Analog Input	High Speed Counter	Pulse Generator	Ethernet	Serial Line
TM221M16R• TM221C••R	X	X	X	X	–	–	X
TM221C••U	X	X	X	X	X	–	X
TM221ME16R• TM221CE••R	X	X	X	X	–	X	X
TM221M16T• TM221M32TK TM221C••T	X	X	X	X	X	–	X
TM221ME16T• TM221ME32TK TM221CE••T TM221CE••U	X	X	X	X	X	X	X

X Available for configuration in EcoStruxure Machine Expert - Basic. For information on how to configure:

- Digital inputs, refer to [Configuring Digital Inputs](#), page 63
- Digital outputs, refer to [Configuring Digital Outputs](#), page 66
- Analog inputs, refer to [Configuring Analog Inputs](#), page 67
- High speed counters, refer to [Configuring High Speed Counters](#), page 69
- Pulse generators, refer to [Configuring Pulse Generators](#), page 77
- Ethernet, refer to [Configuring Ethernet](#), page 95
- Serial lines, refer to [Configuring Serial Line](#), page 122.

Updating Firmware using Executive Loader Wizard

Overview

You can update the firmware of the controller using the Executive Loader wizard.

Refer to *Controller States and Behavior*, page 37 for information concerning the state of the firmware in your controller.

Updating the Firmware of the Controller

To launch the **ExecLoader** wizard, follow these steps:

Step	Action
1	Close all Windows applications, including virtual machines.
2	Click Start > Programs > Schneider Electric > EcoStruxure Machine Expert - Basic > EcoStruxure Machine Expert - Basic Firmware Update or run the <i>ExecLoaderWizard.exe</i> from <i>EcoStruxure Machine Expert - Basic installation folder \Execloader</i> folder.

Controller Firmware Compatibility

This table presents the controller firmware compatibility:

Ethernet Hardware Type	Controller Firmware Version	
	FW < 1.12.1.1	FW ≥ 1.12.1.1
Legacy: SV on the product label without the suffix 'A' (System word %SW61, page 175 = 1)	Compatible	Compatible
Type A: SV on the product label with the suffix 'A' (System word %SW61, page 175 = 2)	Not compatible	Compatible

Embedded Input/Output Configuration

What's in This Chapter

Digital Input Configuration	63
Digital Output Configuration	66
Analog Input Configuration.....	67
High Speed Counter Configuration	69
Pulse Generator Configuration	77

Overview

This chapter describes how to configure the embedded I/O objects of the M221 Logic Controller.

The number of embedded inputs and outputs depends on the controller reference. For more information, refer to the tables for:

- TM221C Logic Controller, page 18
- TM221M Logic Controller, page 23

Digital Input Configuration

Configuring Digital Inputs

Introduction

By default, all digital inputs are used as regular inputs. Some of the digital inputs are fast and can be used by configuring the high speed counters, page 69 while other inputs can be configured as event sources.

Digital Inputs Configuration

This table describes how to configure the digital inputs:

Step	Action																																																																																																			
1	<p>Click the Digital inputs node in the hardware tree to display the digital input properties.</p> <p>This figure shows the properties of the digital inputs in the editor area:</p> <div data-bbox="331 1541 1216 2020" style="border: 1px solid gray; padding: 5px;"> <p>Digital inputs</p> <table border="1"> <thead> <tr> <th>Used</th> <th>Address</th> <th>Symbol</th> <th>Used by</th> <th>Filtering</th> <th>Latch</th> <th>Run/Stop</th> <th>Event</th> <th>Priority</th> <th>Subroutine</th> <th>Comment</th> </tr> </thead> <tbody> <tr> <td><input type="checkbox"/></td> <td>%I0.0</td> <td></td> <td>Filtering</td> <td>3 ms</td> <td><input type="checkbox"/></td> <td><input type="checkbox"/></td> <td>Not Used</td> <td></td> <td></td> <td></td> </tr> <tr> <td><input type="checkbox"/></td> <td>%I0.1</td> <td></td> <td>Filtering</td> <td>3 ms</td> <td><input type="checkbox"/></td> <td><input type="checkbox"/></td> <td>Not Used</td> <td></td> <td></td> <td></td> </tr> <tr> <td><input type="checkbox"/></td> <td>%I0.2</td> <td></td> <td>Filtering</td> <td>3 ms</td> <td><input type="checkbox"/></td> <td><input type="checkbox"/></td> <td>Not Used</td> <td></td> <td></td> <td></td> </tr> <tr> <td><input type="checkbox"/></td> <td>%I0.3</td> <td></td> <td>Filtering</td> <td>3 ms</td> <td><input type="checkbox"/></td> <td><input type="checkbox"/></td> <td>Not Used</td> <td></td> <td></td> <td></td> </tr> <tr> <td><input type="checkbox"/></td> <td>%I0.4</td> <td></td> <td>Filtering</td> <td>3 ms</td> <td><input type="checkbox"/></td> <td><input type="checkbox"/></td> <td>Not Used</td> <td></td> <td></td> <td></td> </tr> <tr> <td><input type="checkbox"/></td> <td>%I0.5</td> <td></td> <td>Filtering</td> <td>3 ms</td> <td><input type="checkbox"/></td> <td><input type="checkbox"/></td> <td>Not Used</td> <td></td> <td></td> <td></td> </tr> <tr> <td><input type="checkbox"/></td> <td>%I0.6</td> <td></td> <td>Filtering</td> <td>3 ms</td> <td><input type="checkbox"/></td> <td><input type="checkbox"/></td> <td>Not Used</td> <td></td> <td></td> <td></td> </tr> <tr> <td><input type="checkbox"/></td> <td>%I0.7</td> <td></td> <td>Filtering</td> <td>3 ms</td> <td><input type="checkbox"/></td> <td><input type="checkbox"/></td> <td>Not Used</td> <td></td> <td></td> <td></td> </tr> </tbody> </table> <p style="text-align: right;"> <input type="button" value="Apply"/> <input type="button" value="Cancel"/> </p> </div>	Used	Address	Symbol	Used by	Filtering	Latch	Run/Stop	Event	Priority	Subroutine	Comment	<input type="checkbox"/>	%I0.0		Filtering	3 ms	<input type="checkbox"/>	<input type="checkbox"/>	Not Used				<input type="checkbox"/>	%I0.1		Filtering	3 ms	<input type="checkbox"/>	<input type="checkbox"/>	Not Used				<input type="checkbox"/>	%I0.2		Filtering	3 ms	<input type="checkbox"/>	<input type="checkbox"/>	Not Used				<input type="checkbox"/>	%I0.3		Filtering	3 ms	<input type="checkbox"/>	<input type="checkbox"/>	Not Used				<input type="checkbox"/>	%I0.4		Filtering	3 ms	<input type="checkbox"/>	<input type="checkbox"/>	Not Used				<input type="checkbox"/>	%I0.5		Filtering	3 ms	<input type="checkbox"/>	<input type="checkbox"/>	Not Used				<input type="checkbox"/>	%I0.6		Filtering	3 ms	<input type="checkbox"/>	<input type="checkbox"/>	Not Used				<input type="checkbox"/>	%I0.7		Filtering	3 ms	<input type="checkbox"/>	<input type="checkbox"/>	Not Used			
Used	Address	Symbol	Used by	Filtering	Latch	Run/Stop	Event	Priority	Subroutine	Comment																																																																																										
<input type="checkbox"/>	%I0.0		Filtering	3 ms	<input type="checkbox"/>	<input type="checkbox"/>	Not Used																																																																																													
<input type="checkbox"/>	%I0.1		Filtering	3 ms	<input type="checkbox"/>	<input type="checkbox"/>	Not Used																																																																																													
<input type="checkbox"/>	%I0.2		Filtering	3 ms	<input type="checkbox"/>	<input type="checkbox"/>	Not Used																																																																																													
<input type="checkbox"/>	%I0.3		Filtering	3 ms	<input type="checkbox"/>	<input type="checkbox"/>	Not Used																																																																																													
<input type="checkbox"/>	%I0.4		Filtering	3 ms	<input type="checkbox"/>	<input type="checkbox"/>	Not Used																																																																																													
<input type="checkbox"/>	%I0.5		Filtering	3 ms	<input type="checkbox"/>	<input type="checkbox"/>	Not Used																																																																																													
<input type="checkbox"/>	%I0.6		Filtering	3 ms	<input type="checkbox"/>	<input type="checkbox"/>	Not Used																																																																																													
<input type="checkbox"/>	%I0.7		Filtering	3 ms	<input type="checkbox"/>	<input type="checkbox"/>	Not Used																																																																																													
2	<p>Edit the properties to configure the digital inputs.</p> <p>For detailed information on the digital input configuration parameters, refer to the table below.</p>																																																																																																			

This table describes each parameter of the digital input configuration:

Parameter	Editable	Value	Default Value	Description
Used	No	True/False	False	Indicates whether the input channel is being used in a program or not.
Address	No	%I0.x	–	Displays the address of the digital input on the controller, where x represents the channel number. If the controller has 8 digital input channels, x varies from 0...7. If the controller has 16 digital input channels, x varies from 0...15. For example, %I0.2 is the third digital input channel of the logic controller.
Symbol	Yes	–	–	Allows you to specify a symbol to associate with the digital input object. Double-click in the Symbol column, type the name of the symbol and press Enter .
Used by	No	any	Filtering	Displays the name of the component that uses the input channel. For example, if the input channel is used by a subroutine, this field displays User logic . The possible values in this field are: <ul style="list-style-type: none">• User logic• Filtering• Latch• Run/Stop• Event• %HSCx where x is the high speed counter instance on the controller• %FCy where y is the fast counter instance on the controller If an input is being used by more than one operation, all values, separated by commas, are displayed in this field.
Filtering	Yes	No Filter 3 ms 12 ms	3 ms	Allows you to select the noise filter duration for the input channel. Using a filter for the digital inputs reduces the noise on the controller input. If you select filter for an input, you cannot configure that input for: <ul style="list-style-type: none">• Latch• Event
Latch	Yes	True/False	False	Allows you to enable or disable latching for the inputs configured as events (%I0.2...%I0.5). By default, this option is disabled due to default value of Filtering . Set the Filtering to No Filter to enable the Latch option. Latching enables pulses with a duration shorter than the controller scan time to be memorized. When a pulse duration is shorter than a scan time and has a value greater than or equal to 1 ms, the controller latches the pulse, which is then updated in the next scan. If you enable Latch for an input, you cannot configure that input for: <ul style="list-style-type: none">• Filtering• Run/Stop• Event
Run/Stop	Yes	True/False	False	Allows you to configure 1 digital input as an additional Run/Stop switch. If you configure a digital input as Run/Stop switch, you cannot use the input in any other function block (for example, high speed counter function block, fast counter function block, and so on). If you enable Run/Stop for an input, you cannot configure that input for: <ul style="list-style-type: none">• Latch• Event

Parameter	Editable	Value	Default Value	Description
Event	Yes	Not Used Falling Edge Rising Edge Both edges	Not Used	<p>Allows you to select an event that triggers the inputs %I0.2...%I0.5.</p> <p>By default, this option is disabled due to the default value of Filtering. Set Filtering to No Filter to enable the Event option.</p> <p>When you select an event from the drop-down list (other than Not Used):</p> <ul style="list-style-type: none"> • The Priority parameter is enabled to allow you to set the priority of the event. • An event task is created and displayed (see EcoStruxure Machine Expert - Basic, Operating Guide) in the Configuration tab.
Priority	Yes	0...7	7	<p>Allows you to set the priority of the triggering event for the inputs %I0.2...%I0.5.</p> <p>You can set the priority of each event using the Priority parameter that is editable only for the inputs configured as event.</p> <p>Assign each configured event a different priority: if 2 events have same priority, a detected error message appears in the window.</p>
Subroutine	No	<i>any</i>	<i>empty</i>	Displays the number of the subroutine associated with an input configured as an event.
Comment	Yes	–	–	<p>Allows you to specify a comment to associate with the digital input object.</p> <p>Double-click in the Comment column, type the comment and press Enter.</p>

Additional configuration details are displayed in the **Programming** tab. For more information, refer to Digital Inputs (%I), page 153.

Digital Output Configuration

Configuring Digital Outputs

Introduction

By default, all digital outputs are used as regular outputs. For controllers equipped with transistor outputs, 2 outputs are fast transistor outputs and can be used by configuring the pulse generators, page 77.

Digital Outputs Configuration

This table describes how to configure the digital outputs:

Step	Action																																																															
1	<p>Click the Digital outputs node in the hardware tree to display the digital output properties.</p> <p>This figure shows the properties of the digital outputs in the editor area:</p> <div data-bbox="357 797 1235 1272" style="border: 1px solid gray; padding: 5px;"> <p>Digital outputs</p> <table border="1"> <thead> <tr> <th>Used</th> <th>Address</th> <th>Symbol</th> <th>Used by</th> <th>Status Alarm</th> <th>Fallback value</th> <th>Comment</th> </tr> </thead> <tbody> <tr><td><input type="checkbox"/></td><td>%Q0.0</td><td></td><td></td><td><input type="checkbox"/></td><td>0</td><td></td></tr> <tr><td><input type="checkbox"/></td><td>%Q0.1</td><td></td><td></td><td><input type="checkbox"/></td><td>0</td><td></td></tr> <tr><td><input type="checkbox"/></td><td>%Q0.2</td><td></td><td></td><td><input type="checkbox"/></td><td>0</td><td></td></tr> <tr><td><input type="checkbox"/></td><td>%Q0.3</td><td></td><td></td><td><input type="checkbox"/></td><td>0</td><td></td></tr> <tr><td><input type="checkbox"/></td><td>%Q0.4</td><td></td><td></td><td><input type="checkbox"/></td><td>0</td><td></td></tr> <tr><td><input type="checkbox"/></td><td>%Q0.5</td><td></td><td></td><td><input type="checkbox"/></td><td>0</td><td></td></tr> <tr><td><input type="checkbox"/></td><td>%Q0.6</td><td></td><td></td><td><input type="checkbox"/></td><td>0</td><td></td></tr> <tr><td><input type="checkbox"/></td><td>%Q0.7</td><td></td><td></td><td><input type="checkbox"/></td><td>0</td><td></td></tr> </tbody> </table> <p style="text-align: right;"> <input type="button" value="Apply"/> <input type="button" value="Cancel"/> </p> </div>	Used	Address	Symbol	Used by	Status Alarm	Fallback value	Comment	<input type="checkbox"/>	%Q0.0			<input type="checkbox"/>	0		<input type="checkbox"/>	%Q0.1			<input type="checkbox"/>	0		<input type="checkbox"/>	%Q0.2			<input type="checkbox"/>	0		<input type="checkbox"/>	%Q0.3			<input type="checkbox"/>	0		<input type="checkbox"/>	%Q0.4			<input type="checkbox"/>	0		<input type="checkbox"/>	%Q0.5			<input type="checkbox"/>	0		<input type="checkbox"/>	%Q0.6			<input type="checkbox"/>	0		<input type="checkbox"/>	%Q0.7			<input type="checkbox"/>	0	
Used	Address	Symbol	Used by	Status Alarm	Fallback value	Comment																																																										
<input type="checkbox"/>	%Q0.0			<input type="checkbox"/>	0																																																											
<input type="checkbox"/>	%Q0.1			<input type="checkbox"/>	0																																																											
<input type="checkbox"/>	%Q0.2			<input type="checkbox"/>	0																																																											
<input type="checkbox"/>	%Q0.3			<input type="checkbox"/>	0																																																											
<input type="checkbox"/>	%Q0.4			<input type="checkbox"/>	0																																																											
<input type="checkbox"/>	%Q0.5			<input type="checkbox"/>	0																																																											
<input type="checkbox"/>	%Q0.6			<input type="checkbox"/>	0																																																											
<input type="checkbox"/>	%Q0.7			<input type="checkbox"/>	0																																																											
2	<p>Edit the properties to configure the digital outputs.</p> <p>For detailed information on the digital output configuration parameters, refer to the table below.</p>																																																															

This table describes each parameter of the digital output configuration:

Parameter	Editable	Value	Default Value	Description
Used	No	True/False	False	Indicates whether the output channel is being used in a program or not.
Address	No	%Q0.x	–	Displays the address of the digital output on the controller, where x represents the channel number. If the controller has 8 digital output channels, x varies from 0...7. If the controller has 16 digital output channels, x varies from 0...15. For example, %Q0.2 is the third digital output channel on the controller.
Symbol	Yes	–	–	Allows you to specify a symbol to associate with the digital output object. Double-click in the Symbol column, type the name of the symbol and press Enter .
Used by	No	any	empty	Displays the name of the component that uses the output channel. For example, if the output channel is used as status alarm, it displays Alarm .
Status Alarm	Yes	True/False	False	Allows you to enable or disable the status alarm for the output (%Q0.0...%Q0.7). You can configure only one output channel for the status alarm. You cannot configure an output as status alarm if the output is used in a program. The value of the status alarm is 1 when the controller is in the state <i>RUNNING</i> , and 0 in all other state
Fallback value	Yes	1 or 0	0	Specify the value to apply to this output (fallback to 0 or fallback to 1) when the logic controller enters the <i>STOPPED</i> or an exception state. The default value is 0. If Maintain values fallback mode is configured, the output retains its current value when the logic controller enters the <i>STOPPED</i> or an exception state. This field is disabled for the output configured as Status Alarm .
Comment	Yes	–	–	Allows you to specify a comment to associate with the digital output object. Double-click in the Comment column, type the comment and press Enter .

Additional configuration details are displayed in the **Programming** tab. For more information, refer to Digital Outputs (%Q), page 154.

Analog Input Configuration

Configuring Analog Inputs

Introduction

The analog inputs do not have any configurable property in EcoStruxure Machine Expert - Basic. By default, analog inputs are used as regular inputs.

Analog Inputs Configuration

This table describes how to configure the analog inputs:

Step	Action																																																			
1	<p>Click the Analog inputs node in the hardware tree to display the analog input properties.</p> <p>This figure shows the properties of the analog inputs in the editor area:</p> <table border="1" style="margin-left: 20px;"> <thead> <tr> <th colspan="12">Analog inputs</th> </tr> <tr> <th></th> <th>Used</th> <th>Address</th> <th>Symbol</th> <th>Type</th> <th>Scope</th> <th>Minimum</th> <th>Maximum</th> <th>Filter level</th> <th>Filter Unit</th> <th>Sampling</th> <th>Units</th> <th>Comment</th> </tr> </thead> <tbody> <tr> <td></td> <td><input type="checkbox"/></td> <td>%IW0.0</td> <td></td> <td>0 - 10 V</td> <td>Normal</td> <td>0</td> <td>1000</td> <td>0</td> <td></td> <td></td> <td></td> <td></td> </tr> <tr> <td></td> <td><input type="checkbox"/></td> <td>%IW0.1</td> <td></td> <td>0 - 10 V</td> <td>Normal</td> <td>0</td> <td>1000</td> <td>0</td> <td></td> <td></td> <td></td> <td></td> </tr> </tbody> </table>	Analog inputs													Used	Address	Symbol	Type	Scope	Minimum	Maximum	Filter level	Filter Unit	Sampling	Units	Comment		<input type="checkbox"/>	%IW0.0		0 - 10 V	Normal	0	1000	0						<input type="checkbox"/>	%IW0.1		0 - 10 V	Normal	0	1000	0				
Analog inputs																																																				
	Used	Address	Symbol	Type	Scope	Minimum	Maximum	Filter level	Filter Unit	Sampling	Units	Comment																																								
	<input type="checkbox"/>	%IW0.0		0 - 10 V	Normal	0	1000	0																																												
	<input type="checkbox"/>	%IW0.1		0 - 10 V	Normal	0	1000	0																																												
2	<p>Edit the properties to configure the analog inputs.</p> <p>For detailed information on the analog input configuration parameters, refer to the table below.</p>																																																			

This table describes each parameter of the analog input configuration:

Parameter	Editable	Value	Default Value	Description
Used	No	True/False	False	Indicates whether the input channel is being used in a program or not.
Address	No	%IW0.x	–	Displays the address of the analog input on the controller, where x represents the channel number. If the controller has 2 analog input channels, x is either 0 or 1. For example, %IW0.1 is the second analog input channel on the controller.
Symbol	Yes	–	–	Allows you to specify a symbol to associate with the analog input object. Double-click in the Symbol column, type the name of the symbol and press Enter .
Type	No	0 - 10 V	0 - 10 V	Indicates the channel mode. For example, 0 - 10 V refers to the channel that can be used for an electrical input of voltage type in the range 0...10 V.
Scope	No	Normal	Normal	Indicates the range of values for a channel.
Minimum	No	0	0	Indicates the lower measurement limit.
Maximum	No	1000	1000	Indicates the upper measurement limit.
Filter level	No	0	0	Indicates the filtering value. Multiply by the Filter Unit value to obtain the filtering time.
Filter Unit	No	100 ms	<i>empty</i>	Specifies the unit of time for the filtering value.
Sampling	No	–	<i>empty</i>	–
Units	No	<i>any</i>	<i>empty</i>	Indicates the unit of the analog input.
Comment	Yes	–	–	Allows you to specify a comment to associate with the analog input object. Double-click in the Comment column, type the comment and press Enter .

Additional configuration details are displayed in the **Programming** tab. For more information, refer to Analog Inputs (%IW), page 154.

High Speed Counter Configuration

Configuring High Speed Counters

Introduction

You can configure high speed counters to perform any one of the following functions:

- Single Phase
- Dual Phase [Pulse / Direction]
- Dual Phase [Quadrature X1]
- Dual Phase [Quadrature X2]
- Dual Phase [Quadrature X4]
- Frequency Meter

For information on how to select a function, refer to High Speed Counter in Counter Modes (see Modicon M221 Logic Controller, Advanced Functions Library Guide) or High Speed Counter in Frequency Meter Mode (see Modicon M221 Logic Controller, Advanced Functions Library Guide).

The **High Speed Counter** function block works at a maximum frequency of 100 kHz for all counting modes with a range of 0 to 65535 in single word and 0 to 4294967295 in double word.

The **High Speed Counter** function blocks use dedicated inputs and auxiliary inputs and outputs. These inputs and outputs are not reserved for the exclusive use of **High Speed Counter** function blocks:

- If the dedicated input/output is not used by an HSC instance, it is available for the application as a regular digital input/output.
- If the application does not use an HSC dedicated input/output as a regular digital input/output, it is available for the corresponding HSC instance.

Single Phase I/O Assignment

	Main Inputs		Auxiliary Inputs		Reflex Outputs	
%HSC0	%I0.0	-	%I0.2	%I0.3	%Q0.2	%Q0.3
%HSC1	%I0.6	-	%I0.5	%I0.4	%Q0.4	%Q0.5
%HSC2	%I0.1	-	-	-	%Q0.2	%Q0.3
%HSC3	%I0.7	-	-	-	%Q0.4	%Q0.5
Single Phase	Pulse input	Not used	Preset input	Catch input	Reflex output 0	Reflex output 1

Dual Phase Pulse / Direction I/O Assignment

	Main Inputs		Auxiliary Inputs		Reflex Outputs	
%HSC0	%I0.0	%I0.1	%I0.2	%I0.3	%Q0.2	%Q0.3
%HSC1	%I0.6	%I0.7	%I0.5	%I0.4	%Q0.4	%Q0.5
Pulse / Direction	Pulse input	Direction input	Preset input	Catch input	Reflex output 0	Reflex output 1

Dual Phase Quadrature I/O Assignment

	Main Inputs		Auxiliary Inputs		Reflex Outputs	
%HSC0	%I0.0	%I0.1	%I0.2	%I0.3	%Q0.2	%Q0.3
%HSC1	%I0.6	%I0.7	%I0.5	%I0.4	%Q0.4	%Q0.5
Quadrature X1	Pulse input Phase A	Pulse input Phase B	Preset input	Catch input	Reflex output 0	Reflex output 1
Quadrature X2	Pulse input Phase A	Pulse input Phase B	Preset input	Catch input	Reflex output 0	Reflex output 1
Quadrature X4	Pulse input Phase A	Pulse input Phase B	Preset input	Catch input	Reflex output 0	Reflex output 1

Frequency Meter I/O Assignment

	Main Inputs		Auxiliary Inputs		Reflex Outputs	
%HSC0	%I0.0	-	-	-	-	-
%HSC1	%I0.6	-	-	-	-	-
Frequency Meter	Pulse input	Not used	Not used	Not used	Not used	Not used

High Speed Counters Configuration

This table describes how to configure the high speed counters:

Step	Description																														
1	<p>Click the High Speed Counters node in the hardware tree.</p> <p>Result: The High Speed Counters list is displayed:</p> <div style="border: 1px solid gray; padding: 5px; margin: 10px 0;"> <p>High Speed Counters</p> <table border="1"> <thead> <tr> <th>Configured</th> <th>Address</th> <th>Symbol</th> <th>Type</th> <th>Configuration</th> <th>Comment</th> </tr> </thead> <tbody> <tr> <td><input type="checkbox"/></td> <td>%HSC0</td> <td></td> <td>Not Configured</td> <td>...</td> <td></td> </tr> <tr> <td><input type="checkbox"/></td> <td>%HSC1</td> <td></td> <td>Not Configured</td> <td>...</td> <td></td> </tr> <tr> <td><input type="checkbox"/></td> <td>%HSC2</td> <td></td> <td>Not Configured</td> <td>...</td> <td></td> </tr> <tr> <td><input type="checkbox"/></td> <td>%HSC3</td> <td></td> <td>Not Configured</td> <td>...</td> <td></td> </tr> </tbody> </table> </div>	Configured	Address	Symbol	Type	Configuration	Comment	<input type="checkbox"/>	%HSC0		Not Configured	...		<input type="checkbox"/>	%HSC1		Not Configured	...		<input type="checkbox"/>	%HSC2		Not Configured	...		<input type="checkbox"/>	%HSC3		Not Configured	...	
Configured	Address	Symbol	Type	Configuration	Comment																										
<input type="checkbox"/>	%HSC0		Not Configured	...																											
<input type="checkbox"/>	%HSC1		Not Configured	...																											
<input type="checkbox"/>	%HSC2		Not Configured	...																											
<input type="checkbox"/>	%HSC3		Not Configured	...																											
2	<p>Click ... in under Configuration to select the type of high speed counter to assign and to display the High Speed Counter Assistant window.</p> <p>For detailed information on the high speed counter, refer to the table below.</p>																														

This table describes each parameter of the high speed counters configuration:

Parameter	Editable	Value	Default Value	Description
Configured	No	TRUE/FALSE	FALSE	Indicates whether the high speed counter is being configured in a program or not.
Address	No	%HSC <i>i</i>		Indicates the address of the high speed counter, where <i>i</i> is the object number.
Symbol	Yes	–	–	Allows you to specify a symbol to associate with the high speed counter object. Double-click in the Symbol column to edit the field.
Type	No	Not Configured Single Phase Dual Phase Frequency Meter	Not Configured	Indicates the counter operational mode.
Configuration	Yes	[...] (Button)	Disabled	Allows you to configure the high speed counter parameters using the High Speed Counter Assistant window.
Comment	Yes	–	–	Allows you to specify a comment to associate with the high speed counter object. Double-click in the Comment column to edit the field.

For details on the configuration of the Dual Phase [Pulse / Direction], Dual Phase [Quadrature X1], Dual Phase [Quadrature X2], Dual Phase [Quadrature X4], and Single Phase, refer to Configuring Dual Phase and Single Phase Counters, page 72.

For details on the configuration of the Frequency Meter, refer to Configuring Frequency Meter, page 75.

Configuring Dual Phase and Single Phase Counters

High Speed Counter Assistant

This figure presents an instance of the assistant window for %HSC0 configured as the Dual Phase [Pulse / Direction]:

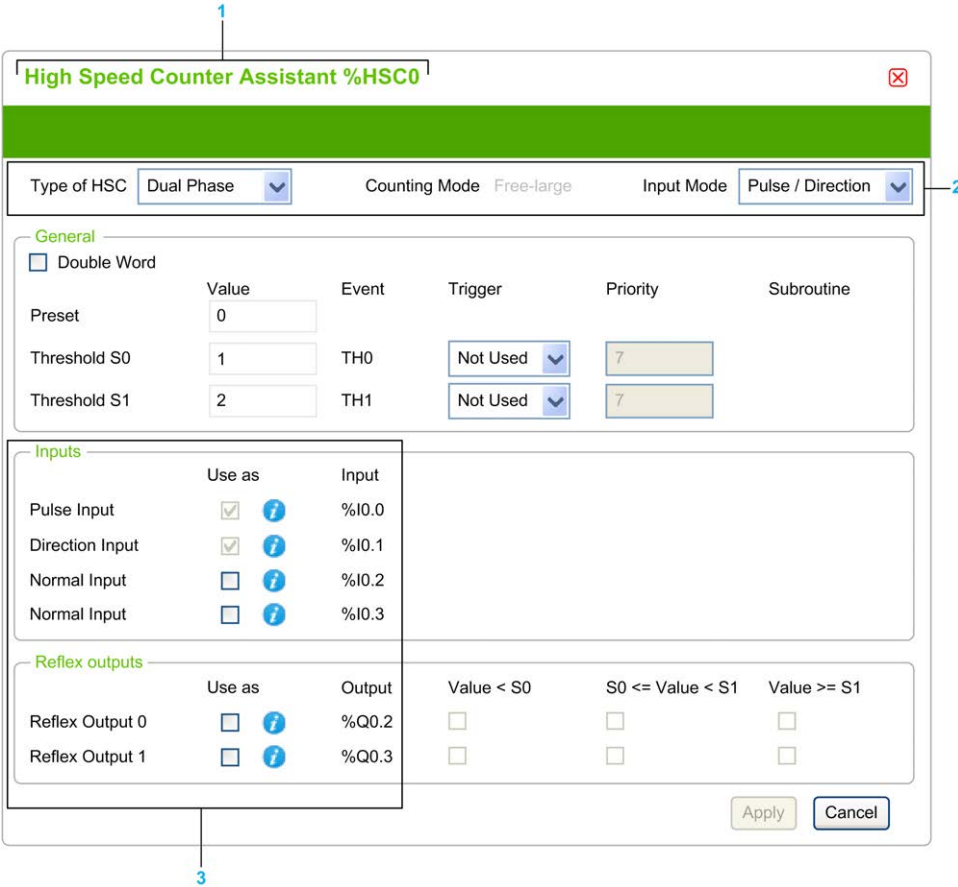

Item	Description
1	Displays the title of the assistant dialog window for the selected HSC instance %HSCi.
2	Allows you to select the HSC type, mode, and dual phase counter type.
3	Displays the dedicated inputs, auxiliary inputs, and reflex outputs. Properties in this area of the assistant window are different for each counter type and the HSC instance. For more details, refer to <i>Dedicated I/O Assignments</i> , page 69.

Common Parameters

This table describes parameters common to all counter types:

Parameter	Editable	Value	Default Value	Description
Type of HSC	Yes	Not Configured Single Phase Dual Phase Frequency Meter	-	Indicates the selected counter operational mode and allows you to change it. The options depend on the instance and on the type of HSC in the other instances. Refer to <i>Dedicated I/O Assignments</i> , page 69.
Counting Mode	No	Free Large	-	Indicates the selected counter operational mode. The options depend on the instance and on the type of HSC in the other instances. Refer to <i>Dedicated I/O Assignments</i> , page 69.
Input Mode	Yes	Pulse / Direction Quadrature X1 Quadrature X2 Quadrature X4	-	Indicates the selected counter operational mode and allows you to change it. The options depend on the instance and on the type of HSC in the other instances. Refer to <i>Dedicated I/O Assignments</i> , page 69.
Double Word	Yes	TRUE/FALSE	FALSE	Allows you to toggle between input data size of Word (16 bits) and Double Word (32 bits). Enabling this field changes the data size from Word (16 bits) to Double Word (32 bits).
Preset	Yes	0...65535 (Word)	0 (Word)	Allows you to specify the preset value for counting functions.
		0...4294967295 (Double Word)	0 (Double Word)	
Threshold S0	Yes	0...65535 (Word)	65535 (Word)	Allows you to specify the value of the HSC flag <i>S0</i> that contains the value of the threshold <i>TH0</i> .
		0...4294967295 (Double Word)	4294967295 (Double Word)	
Threshold S1	Yes	0...65535 (Word)	0...65535 (Word)	Allows you to specify the value for the HSC flag <i>S1</i> that contains the value of the threshold <i>TH1</i> .
		0...4294967295 (Double Word)	0... 4294967295 (Double Word)	
Trigger	Yes	Not Used Falling Edge Rising Edge Both edges	Not Used	Allows you to select a triggering function for an event (for both threshold <i>TH0</i> and <i>TH1</i>) from the list. Selecting a triggering function makes the Priority parameter editable.
Priority	Yes	0...7	7	Allows you to set the priority of the triggering function of an event (for both threshold <i>TH0</i> and <i>TH1</i>). This field is greyed until you select a triggering function.
Subroutine	No	<i>any</i>	<i>empty</i>	Displays the subroutine associated with an input configured as an event (for both threshold <i>TH0</i> and <i>TH1</i>).
Normal Input	Yes	TRUE/FALSE	FALSE	Configurable as Preset Input by selecting the Use as check box, only on <i>%HSC0</i> and <i>%HSC1</i> , respectively <i>%IO.2</i> and <i>%IO.5</i> .
Normal Input	Yes	TRUE/FALSE	FALSE	Configurable as Catch Input by selecting the Use as check box, only on <i>%HSC0</i> and <i>%HSC1</i> , respectively <i>%IO.3</i> and <i>%IO.4</i> .

Parameter	Editable	Value	Default Value	Description
Reflex Output 0	Yes	TRUE/FALSE	FALSE	Configure Reflex output 0 %Q0.2 for either %HSC0 or %HSC2. Configure Reflex output 0 %Q0.4 for either %HSC1 or %HSC3.
Reflex Output 1	Yes	TRUE/FALSE	FALSE	Configure Reflex output 1 %Q0.3 for either %HSC0 or %HSC2. Configure Reflex output 1 %Q0.5 for either %HSC1 or %HSC3.
Value < S0	Yes	TRUE/FALSE	FALSE	Allows you to enable or disable the condition in which the counter is constantly compared to the output value to set the reflex output when the output value is lower than the value of HSC flag S0.
S0 <= Value < S1	Yes	TRUE/FALSE	FALSE	Allows you to enable or disable the condition in which the counter is constantly compared to the output value to set the reflex output when the output value is higher than or equals to the value of the HSC flag S0 and the output value is lower than the value of the HSC flag S1.
Value >= S1	Yes	TRUE/FALSE	FALSE	Allows you to enable or disable the condition in which the counter is constantly compared to the output value to set the reflex output when the output value is higher than or equals to the value of HSC flag S1.

Dual Phase [Pulse / Direction] Parameters

This table describes parameters specific to Dual Phase [Pulse / Direction]:

Parameter	Editable	Value	Default Value	Description
Pulse Input	No	TRUE/FALSE	TRUE	Configured as pulse input, only on %HSC0 and %HSC1, respectively %I0.0 and %I0.6.
Direction Input	No	TRUE/FALSE	TRUE	Configured as directional input, only on %HSC0 and %HSC1, respectively %I0.1 and %I0.7. <ul style="list-style-type: none"> TRUE = down counting FALSE = up counting

Dual Phase [Quadrature X1], Dual Phase [Quadrature X2], and Dual Phase [Quadrature X4] Parameters

This table describes parameters specific to Dual Phase [Quadrature X1], Dual Phase [Quadrature X2], and Dual Phase [Quadrature X4]:

Parameter	Editable	Value	Default Value	Description
Pulse Input Phase A	No	TRUE/FALSE	TRUE	Configured as pulse input for phase A, only on %HSC0 and %HSC1, respectively %I0.0 and %I0.6.
Pulse Input Phase B	No	TRUE/FALSE	TRUE	Configured as pulse input for phase B, only on %HSC0 and %HSC1, respectively %I0.1 and %I0.7.

Single Phase Parameters

This table describes a parameter specific to Single Phase:

Parameter	Editable	Value	Default Value	Description
Pulse Input	No	TRUE/FALSE	TRUE	You can configure up to four HSC in Single Phase HSC type, they use, as a pulse input: <ul style="list-style-type: none"> • %I0.0 for %HSC0 • %I0.6 for %HSC1 • %I0.1 for %HSC2 • %I0.7 for %HSC3

Configuring Frequency Meter

High Speed Counter Assistant

This figure presents the **High Speed Counter Assistant (%HSC0)** window for the counter type *Frequency Meter*:

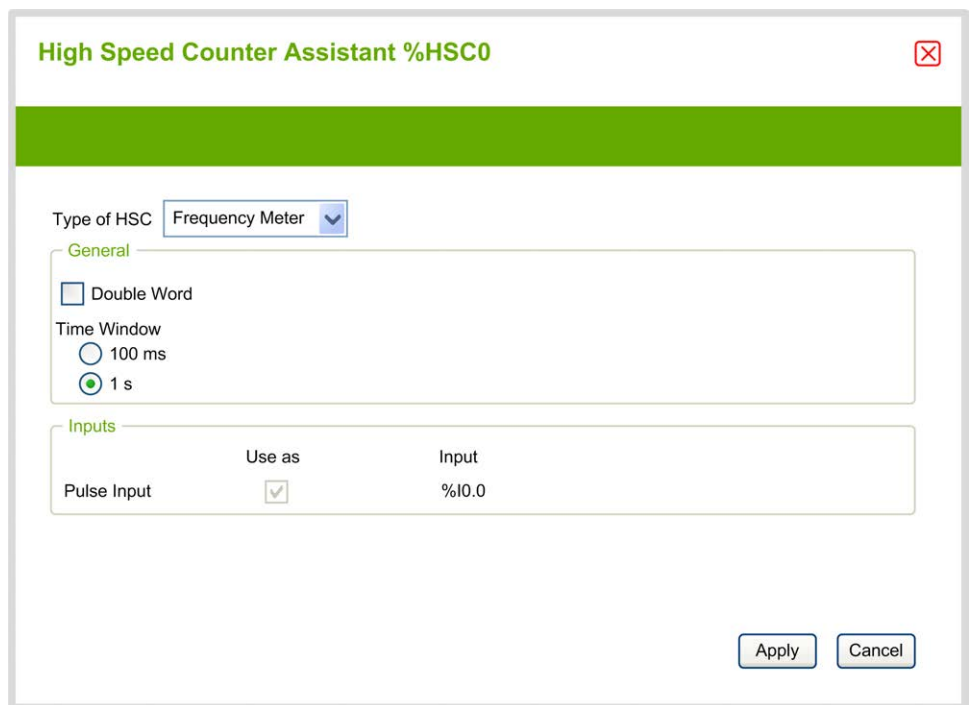

Frequency Meter Parameters

This table describes each parameter of the **High Speed Counter Assistant (%HSCi)** window for the counter type *Frequency Meter*:

Parameter	Editable	Value	Default Value	Description
Type of HSC	Yes	Not Configured Single Phase Dual Phase Frequency Meter	Frequency Meter	Indicates the selected counter operational mode and allows you to change it. The <i>Frequency Meter</i> is configurable on %HSC0 and/or %HSC1. Refer to the <i>Frequency Meter I/O Assignment</i> , page 70.
Double Word	Yes	TRUE/FALSE	FALSE	Use a 32-bit preset word. Enabling this field changes the data size from Word (16 bits) to Double Word (32 bits).
Time Window	Yes	100 ms 1 s	1 s	Allows you to select the time base to measure the frequency between 100 Hz and 100 kHz.
Pulse Input	No	TRUE/FALSE	TRUE	Indicates the input used as pulse input, %I0.0 for %HSC0 or %I0.6 for %HSC1.

Additional configuration details are displayed in the **Programming** tab.

For more details on the *High Speed Counter* function block, refer to the *Modicon M221 Logic Controller Advanced Functions Library Guide*, chapter *High Speed Counter Function Block (%HSC)*.

Pulse Generator Configuration

Configuring Pulse Generators

Introduction

The pulse generator function blocks, *Pulse (PLS)*, *Pulse Width Modulation (PWM)*, *Pulse Train Output (PTO)* and *Frequency Generator (FREQGEN)* are used to generate square or modulated wave signals on dedicated output channels %Q0.0 or %Q0.1.

The PWM outputs feature a modulated wave signal with a variable width and duty cycle, while the PTO outputs generate a square wave to control a linear single-axis stepper or servo drive in open loop mode. The PLS also creates a square wave for a programmed number of pulses.

Pulse Generators Configuration

This table describes how to configure the pulse generators:

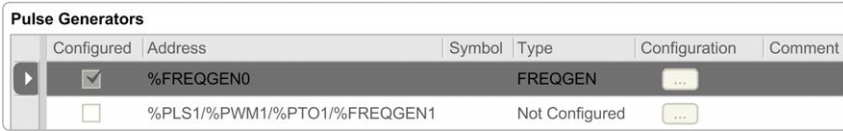
Step	Action
1	<p>Click the Pulse Generators node in the hardware tree to display the pulse generator properties.</p> <p>This figure presents the properties of the pulse generators in the editor area:</p> 
2	<p>Edit the properties and click [...] to configure the pulse generator output.</p> <p>For detailed information on the pulse generator configuration parameters, refer to the table below.</p>

This table describes the parameters of the pulse generator:

Parameter	Editable	Value	Default Value	Description
Configured	No	True/False	False	Indicates whether the pulse generated output is being configured in a program or not.
Address	No	%PLSx %PWMx %PTOx %FREQGENx	%PLSx/%PWMx/%PTOx/%FREQGENx	Displays the address of the <i>Pulse</i> output, <i>Pulse Width Modulation</i> output, <i>Pulse Train Output</i> , or <i>Frequency Generator</i> where x is the output number.
Symbol	Yes	–	–	Allows you to specify a symbol to associate with the pulse generator object. Double-click in the Symbol column to edit the field.
Type	No	Not Configured PLS PWM PTO FREQGEN	Not Configured	Displays the type of the pulse generator used for the output channel.
Configuration	Yes	[...] (Button)	Enabled	Allows you to configure the pulse generator using the Pulse Generator Assistant window.
Comment	Yes	–	–	Allows you to specify a comment to associate with the pulse generator object. Double-click in the Comment column to edit the field.

PLS Configuration

Refer to Configuring Pulse (%PLS), page 79.

For more details on the *Pulse* function block, refer to the Modicon M221 Logic Controller Advanced Functions Library Guide, chapter Pulse (%PLS) (see Modicon M221 Logic Controller, Advanced Functions Library Guide).

PWM Configuration

Refer to Configuring Pulse Width Modulation (%PWM), page 81.

For more details on the *Pulse Width Modulation* function block, refer to the Modicon M221 Logic Controller Advanced Functions Library Guide, chapter Pulse Width Modulation (%PWM) (see Modicon M221 Logic Controller, Advanced Functions Library Guide).

PTO Configuration

Refer to Configuring Pulse Train Output (%PTO), page 82

For more details on the *Pulse Train Output* function block, refer to the Modicon M221 Logic Controller Advanced Functions Library Guide, chapter Pulse Train Output (%PTO) (see Modicon M221 Logic Controller, Advanced Functions Library Guide).

Frequency Generator Configuration

Refer to Configuring Frequency Generator (%FREQGEN), page 82

For more details on the *FREQGEN* function block, refer to the Modicon M221 Logic Controller Advanced Functions Library Guide, chapter Frequency Generator (%FREQGEN) (see Modicon M221 Logic Controller, Advanced Functions Library Guide).

Configuring Pulse (%PLS)

Pulse Generator Assistant for PLS

This graphic presents the **Pulse Generator Assistant** window when the **Type of pulse generator** is set to **PLS**:

The screenshot shows a window titled "Pulse Generator Assistant %PLS0" with a close button in the top right corner. The window has a green header bar. Below the header, there are three sections: "General", "Behavior", and "Period".

- General**: "Type of pulse generator" is set to "PLS" (dropdown menu). A checkbox labeled "%Q0.0" is checked.
- Behavior**: A checkbox labeled "Double Word" is unchecked.
- Period**: "Time Base" is set to "1 s" (dropdown menu). "Preset" is set to "0" (text input field).

At the bottom right of the window, there are two buttons: "Apply" and "Cancel".

The table describes each parameter available when the channel is configured in **PLS** mode:

Parameter	Value	Default Value	Description
Type of pulse generator	Not Configured PLS PWM PTO FREQGEN	PLS	Allows you to choose the type of pulse generator and configure the output properties. Select: <ul style="list-style-type: none"> • PLS to configure the output channels in <i>PLS</i> mode. Refer to Configuring Pulse (%PLS), page 79. • PWM to configure the output channels in <i>PWM</i> mode. Refer to Configuring Pulse Width Modulation (%PWM), page 81. • PTO to configure the output channels in <i>PTO</i> mode. Refer to Configuring Pulse Train Output (%PTO), page 82. • FREQGEN to configure the output channels in <i>FREQGEN</i> mode. Refer to Configuring Frequency Generator (%FREQGEN), page 84.
Double Word	True/False	False	Allows you to toggle between the data size of Word (16 bits) and Double Word (32 bits). By default, this parameter is disabled, which indicates that the current data size is Word (16 bits). Enabling this field changes the data size to Double Word (32 bits).
Time Base	0.1 ms 1 ms 10 ms 1 s	1 s	Allows you to select the time base for the frequency measurement.
Preset	Refer to the table below for complete range of preset values for <i>PLS</i> type pulse generator.	0	Allows you to specify the preset value for the pulse output.

This table presents the range of values of the **Preset** parameter:

Type	Time Base	Preset Value Range
<i>PLS</i>	0.1 ms	1...20000
	1 ms	1...2000
	10 ms	1...200
	1 s	1 or 2

Additional configuration details are displayed in the **Programming** tab.

For more details on the *Pulse* function block, refer to the Modicon M221 Logic Controller Advanced Functions Library Guide, chapter Pulse (%PLS) (see Modicon M221 Logic Controller, Advanced Functions Library Guide).

Configuring Pulse Width Modulation (%PWM)

Pulse Generator Assistant for PWM

This graphic presents the **Pulse Generator Assistant** window when the **Type of pulse generator** is set to **PWM**:

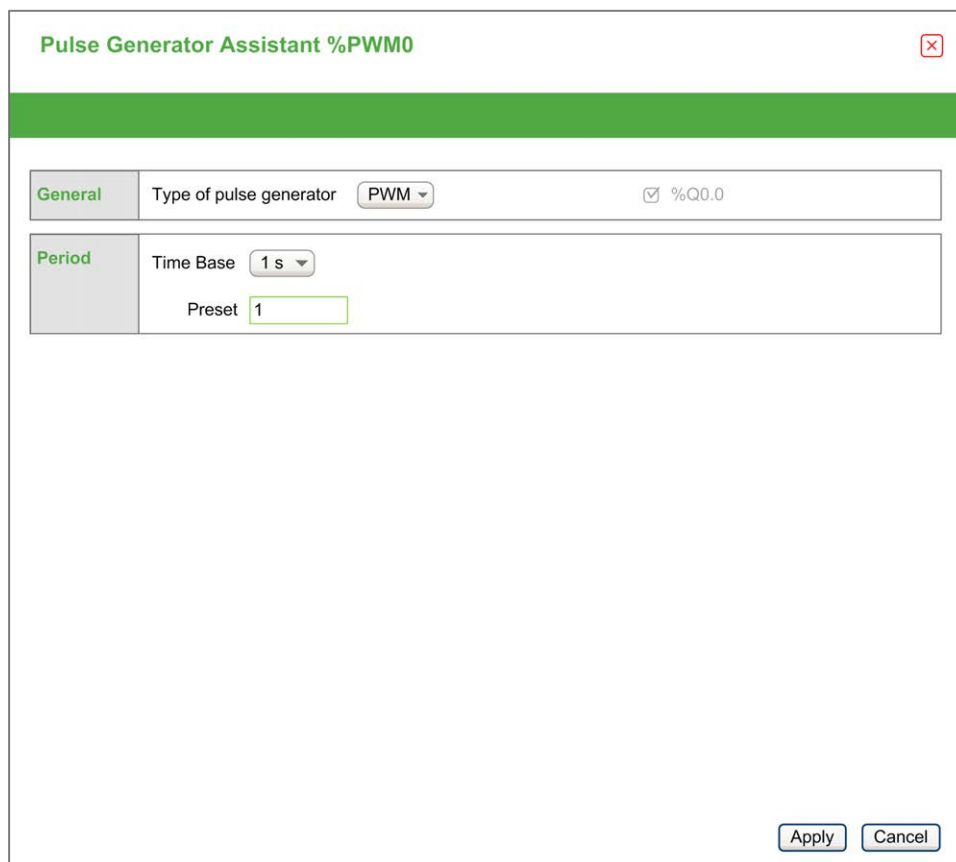

The table describes each parameter available when the channel is configured in **PWM** mode:

Parameter	Value	Default Value	Description
Type of pulse generator	Not Configured PLS PWM PTO FREQGEN	PWM	Allows you to choose the type of pulse generator and configure the output properties. Select: <ul style="list-style-type: none"> • PLS to configure the output channels in <i>PLS</i> mode. Refer to <i>Configuring Pulse (%PLS)</i>, page 79. • PWM to configure the output channels in <i>PWM</i> mode. Refer to <i>Configuring Pulse Width Modulation (%PWM)</i>, page 81. • PTO to configure the output channels in <i>PTO</i> mode. Refer to <i>Configuring Pulse Train Output (%PTO)</i>, page 82. • FREQGEN to configure the output channels in <i>FREQGEN</i> mode. Refer to <i>Configuring Frequency Generator (%FREQGEN)</i>, page 84.
Time Base	0.1 ms 1 ms 10 ms 1 s	1 s	Allows you to select the time base for the frequency measurement.
Preset	Refer to the table below for complete range of preset values for <i>PWM</i> type pulse generator.	0	Allows you to specify the preset value for the <i>PWM</i> output.

This table presents the range of values of the **Preset** parameter:

Type	Time Base	Preset Value Range
PWM	0.1 ms	1...10000
	1 ms	1...1000
	10 ms	1...100
	1 s	1

Additional configuration details are displayed in the **Programming** tab.

For more details on the *Pulse Width Modulation* function block, refer to the Modicon M221 Logic Controller Advanced Functions Library Guide, chapter Pulse Width Modulation (%PWM) (see Modicon M221 Logic Controller, Advanced Functions Library Guide).

Configuring Pulse Train Output (%PTO)

Pulse Generator Assistant for PTO

This graphic presents the **Pulse Generator Assistant** window when the **Type of pulse generator** is set to **PTO**:

Pulse Generator Assistant %PTO0

General
 Type of pulse generator: PTO
 Pulse: %Q0.0
 Output mode: Pulse / Direction
 Direction: %Q0.4

Mechanics
 Backlash Compensation: 0

Software Position Limits
 Enable the software position limits
 Zone of operation: -2e31 to 2e31
 Low limit: -2147483648
 High limit: 2147483647

Motion
 Max. velocity (Hz): 100000
 Start velocity (Hz): 0
 Stop velocity (Hz): 0
 Max. acc. (Hz/ms): 100000
 Fast stop dec. (Hz/ms): 5000
 Max dec. (Hz/ms): 100000

Homing
 REF input: Not Used
 Contact type: Normally opened

Probe activation
 PROBE input: Not Used

Apply Cancel

The table describes each parameter available when the channel is configured in **PTO** mode:

Parameter	Value	Default	Description	
General	Type of pulse generator	Not Configured PLS PWM PTO FREQGEN	PTO Allows you to choose the type of pulse generator and configure the output properties. Select: <ul style="list-style-type: none"> PLS to configure the output channels in <i>PLS</i> mode. Refer to <i>Configuring Pulse (%PLS)</i>, page 79. PWM to configure the output channels in <i>PWM</i> mode. Refer to <i>Configuring Pulse Width Modulation (%PWM)</i>, page 81. PTO to configure the output channels in <i>PTO</i> mode. Refer to <i>Configuring Pulse Train Output (%PTO)</i>, page 82. FREQGEN to configure the output channels in <i>FREQGEN</i> mode. Refer to <i>Configuring Frequency Generator (%FREQGEN)</i>, page 84. 	
	Output mode	Clock Wise / Counter Clock Wise Pulse / Direction	Pulse / Direction Select the pulse Output mode (see Modicon M221 Logic Controller, Advanced Functions Library Guide). NOTE: The Clock Wise / Counter Clock Wise output mode is only valid for PTO0. This mode disables PTO1.	
	Pulse	%Q0.0 for PTO0, %Q0.1 for PTO1	%Q0.0 for PTO0, %Q0.1 for PTO1	When Pulse / Direction is selected in Output mode , select the output that provides the motor operating speed.
	Direction	Not used %Q0.0...16 (depending on controller reference)	%Q0.2	When Pulse / Direction is selected in Output mode , select the output that provides the motor rotation direction. Set to Not used (disabled) if directional output is not required for the application. NOTE: The application must be configured with a functional level of at least Level 5.0 to enable the Not used option.
	Clock Wise	%Q0.0	%Q0.0	When Clock Wise / Counter Clock Wise is selected in Output mode , select the output that provides the signal for forward motor operating speed and direction.
	Counter Clock Wise	%Q0.1	%Q0.1	When Clock Wise / Counter Clock Wise is selected in Output mode , select the output that provides the signal for reverse motor operating speed and direction.
Mechanics	Backlash Compensation	0...65535	0 Set backlash compensation value. The specified number of backlash compensation pulses are not added to the position counter. See Backlash Compensation (see Modicon M221 Logic Controller, Advanced Functions Library Guide).	
Software Position Limits	Enable the software position limits	Enabled Disabled	Enabled Select whether to use the software position limits.	
	Low Limit	-2147483648... 2147483647	-2147483648 Set the software limit position to be detected in the negative direction.	
	High Limit	-2147483648... 2147483647	2147483647 Set the software limit position to be detected in the positive direction.	
Motion	Max. velocity	0...100000	100000 Set the pulse output maximum velocity (in Hz).	
	Start velocity	0...100000	0 Set the pulse output start velocity (see Modicon M221 Logic Controller, Advanced Functions Library Guide) (in Hz). 0 if not used.	
	Stop velocity	0...100000	0 Set the pulse output stop velocity (see Modicon M221 Logic Controller, Advanced Functions Library Guide) (in Hz). 0 if not used.	
	Max. acc.	1...100000	100000 Set the acceleration maximum value (in Hz/ms).	
	Fast stop dec.	1...100000	5000 Set the deceleration value in case an error is detected (in Hz/ms)	
	Max. dec.	1...100000	100000 Set the deceleration maximum value (in Hz/ms).	

Parameter		Value	Default	Description
Homing	REF input	Not Used Input	Not Used	Select whether to use the REF input to set the homing position.
	Contact type	Normally opened Normally closed	Normally opened	Select whether the switch contact default state is open or closed. NOTE: The input type is only available when REF input is selected.
Probe activation	PROBE input	Not Used Input	Not Used	Select whether to use the PROBE input. NOTE: Refer to Regular Input Characteristics for details on the physical characteristics of the selected input.

Additional configuration details are displayed in the **Programming** tab.

For more details on the *Pulse Train Output* function block, refer to the Modicon M221 Logic Controller Advanced Functions Library Guide, chapter Pulse Train Output (%PTO) (see Modicon M221 Logic Controller, Advanced Functions Library Guide).

Configuring Frequency Generator (%FREQGEN)

Pulse Generator Assistant for FREQGEN

This graphic presents the **Pulse Generator Assistant** window when the **Type of pulse generator** is set to **FREQGEN**:

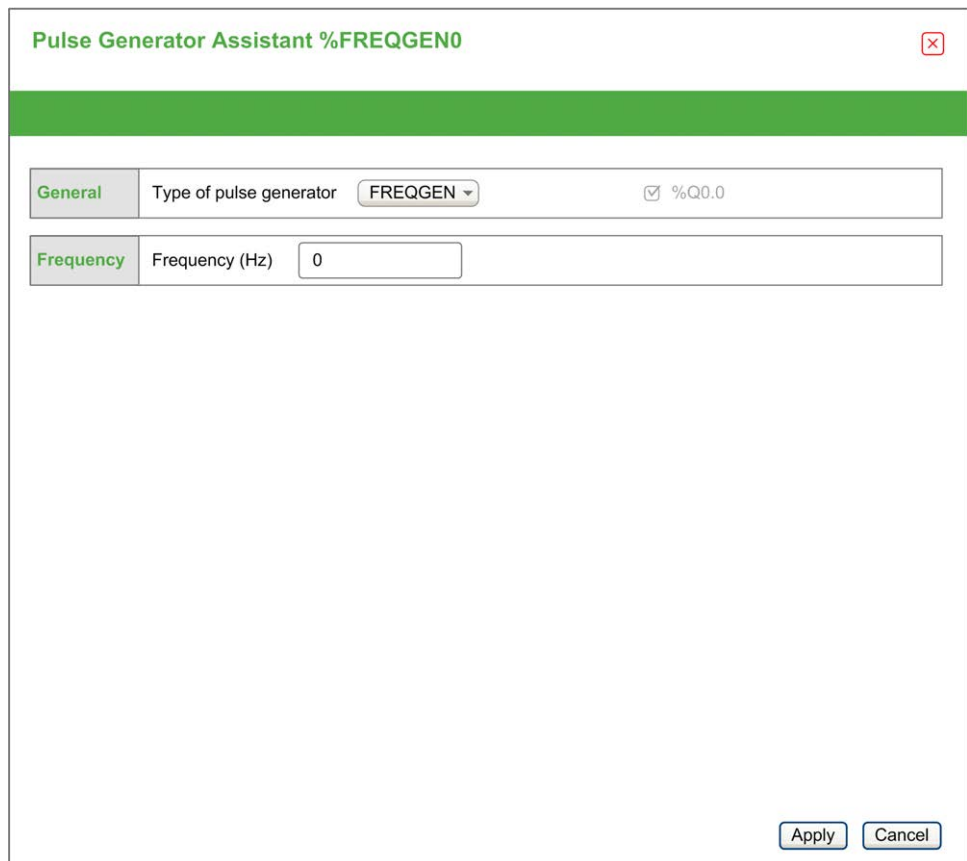

The Frequency Generator (FG) function generates a square wave signal with programmable frequency and duty cycle of 50%. The controller uses an internal clock generator and provides an output signal on a dedicated output channel (%Q0.0). This output signal can directly command a constant motion of the axis. The target frequency is always positive.

For more details on the *FREQGEN* function block, refer to the Modicon M221 Logic Controller Advanced Functions Library Guide, chapter Frequency Generator

(%FREQGEN) (see Modicon M221 Logic Controller, Advanced Functions Library Guide).

I/O Bus Configuration

What's in This Chapter

I/O Configuration General Description.....	86
Maximum Hardware Configuration.....	90
Configuring Cartridges and Expansion Modules.....	94

Overview

This chapter describes how to configure the I/O bus (expansion modules) of the M221 Logic Controller.

I/O Configuration General Description

Introduction

In your project, you can add I/O expansion modules to your M221 Logic Controller to increase the number of digital and analog inputs and outputs over those native to the logic controller itself (embedded I/O).

You can add either TM3 or TM2 I/O expansion modules to the logic controller, and further expand the number of I/O via TM3 transmitter and receiver modules to create remote I/O configurations. Special rules apply in all cases when creating local and remote I/O expansions, and when mixing TM2 and TM3 I/O expansion modules (refer to [Maximum Hardware Configuration](#), page 90).

The I/O expansion bus of the M221 Logic Controller is created when you assemble the I/O expansion modules to the logic controller. I/O expansion modules are considered as external devices in the logic controller architecture and are treated, as such, differently than the embedded I/Os of the logic controller.

I/O Expansion Bus Errors

If the logic controller cannot communicate with one or more I/O expansion modules that is (are) contained in the program configuration and those modules are not configured as optional modules (refer to [Optional I/O Expansion Modules](#), page 57), the logic controller considers it as an I/O expansion bus error. The unsuccessful communication may be detected during the startup of the logic controller or during runtime, and there may be any number of causes. Causes of communication exception on the I/O expansion bus include, among other things, disconnection of or physically missing I/O modules, electromagnetic radiation beyond published environmental specifications, or otherwise, inoperative modules.

During runtime, if an I/O expansion bus error is detected, the diagnostic information is contained in %SW118 and %SW120 , and the red LED indicator labeled **ERR** flashes.

Active I/O Expansion Bus Error Handling

System bit %S106 is set to 0 by default to specify the use of active I/O error handling. The application can set this bit to 1 to use passive I/O error handling instead.

By default, when the logic controller detects a TM3 module in bus communication error, it sets the bus to a "bus off" condition whereby the TM3 expansion module outputs, the input image and the output image are set to 0. A TM3 expansion

module is considered to be in bus communication error when an I/O exchange with the expansion module has been unsuccessful for at least two consecutive bus task cycles. When a bus communication error occurs, bit n of %SW120 is set to 1, where n is the expansion module number, and %SW118 bit 14 is set to 0.

Normal I/O expansion bus operation can only be restored after eliminating the source of the error and performing one of the following:

- Power cycle
- New application download
- Application request through a rising edge on bit %S107
- With EcoStruxure Machine Expert - Basic by selection of the **Initialize Controller** command

Passive I/O Expansion Bus Error Handling

The application can set system bit %S106 to 1 to use passive I/O error handling. This error handling is provided to afford compatibility with previous firmware versions and previous controllers that the M221 Logic Controller replaces.

When passive I/O error handling is in use, the controller attempts to continue data bus exchanges with the modules during bus communication errors. While the expansion bus error persists, the logic controller attempts to re-establish communication on the bus with incommunicative modules, depending on the type of I/O expansion module, TM3 or TM2:

- For TM3 I/O expansion modules, the value of the I/O channels is maintained (**Maintain values**) for approximately 10 seconds while the logic controller attempts to re-establish communication. If the logic controller cannot re-establish communications within that time, all affected TM3 I/O expansion outputs are set to 0.
- For the TM2 I/O expansion modules that may be part of the configuration, the value of the I/O channels is maintained indefinitely. That is to say, the outputs of the TM2 I/O expansion modules are set to **Maintain values** until either power is cycled on the logic controller system, or you issue an **Initialize Controller** command with EcoStruxure Machine Expert - Basic.

In either case, the logic controller continues to solve logic and the embedded I/O continues to be managed by the application (*Managed by application, page 46*) while it attempts to re-establish communication with the incommunicative I/O expansion modules. If the communication is successful, the I/O expansion modules resume to be managed by the application. If communication with the I/O expansion modules is unsuccessful, you must resolve the reason for the unsuccessful communication, and then cycle power on the logic controller system, or issue an **Initialize Controller** command with EcoStruxure Machine Expert - Basic.

The value of the incommunicative I/O expansion modules input image is maintained and the output image value is set by the application.

Further, if the incommunicative I/O module(s) disturb the communication with unaffected modules, the unaffected modules will also be considered in error and their corresponding bit in %SW120 will be set to 1. However, with the ongoing data exchanges that characterize the Passive I/O Expansion Bus Error Handling, the unaffected modules will nonetheless apply the data sent, and will not apply the fallback values as for the incommunicative module.

Therefore, you must monitor within your application the state of the bus and the error state of the module(s) on the bus, and to take the appropriate action necessary given your particular application.

▲ WARNING**UNINTENDED EQUIPMENT OPERATION**

- Include in your risk assessment the possibility of unsuccessful communication between the logic controller and any I/O expansion modules.
- If the “Maintain values” option deployed during an I/O expansion bus error is incompatible with your application, use alternate means to control your application for such an event.
- Monitor the state of the I/O expansion bus using the dedicated system words and take appropriate actions as determined by your risk assessment.

Failure to follow these instructions can result in death, serious injury, or equipment damage.

For more information on the actions taken upon start-up of the logic controller when an I/O expansion bus error is detected, refer to [Optional I/O Expansion Modules](#), page 57.

Restarting the I/O Expansion Bus

When active I/O error handling is being applied, that is, TM3 outputs set to 0 when a bus communication error is detected, the application can request a restart of the I/O expansion bus while the logic controller is still running (without the need for a Cold Start, Warm Start, power cycle, or application download).

System bit %S107 is available to request restarts of the I/O expansion bus. The default value of this bit is 0. The application can set %S107 to 1 to request a restart of the I/O expansion bus. On detection of a rising edge of this bit, the logic controller reconfigures and restarts the I/O expansion bus if all of the following conditions are met:

- %S106 is set to 0 (that is, I/O expansion bus activity is stopped)
- %SW118 bit 14 is set to 0 (I/O expansion bus is in error)
- At least one bit of %SW120 is set to 1 (at least one expansion module is in bus communication error)

If %S107 is set to 1 and any of the above conditions is not met, the logic controller takes no action.

Match Software and Hardware Configuration

The I/O that may be embedded in your controller is independent of the I/O that you may have added in the form of I/O expansion. It is important that the logical I/O configuration within your program matches the physical I/O configuration of your installation. If you add or remove any physical I/O to or from the I/O expansion bus or, depending on the controller reference, to or from the controller (in the form of cartridges), then you must update your application configuration. This is also true for any field bus devices you may have in your installation. Otherwise, there is the potential that the expansion bus or field bus no longer function while the embedded I/O that may be present in your controller continues to operate.

▲ WARNING**UNINTENDED EQUIPMENT OPERATION**

Update the configuration of your program each time you add or delete any type of I/O expansions on your I/O bus, or you add or delete any devices on your field bus.

Failure to follow these instructions can result in death, serious injury, or equipment damage.

Adding an I/O Expansion Module

To add a module in the configuration:

Step	Action
1	Drag-and-drop the I/O expansion module from the catalog to the editor.
2	<p>The following features are available:</p> <ul style="list-style-type: none"> Optional Feature for I/O Expansion Modules, refer to Marking an I/O Expansion Module as Optional in Offline Mode, page 58 Functional Mode feature for I/O Expansion Modules, refer to Selecting the Functional Mode of an I/O Expansion Module in Offline Mode, page 59 <p>In the Device information area, select the Optional module or the Functional Mode check box:</p> <div style="border: 1px solid gray; padding: 5px; margin: 5px 0;"> <p>Device information</p> <div style="display: flex; align-items: center; gap: 10px;"> <input type="checkbox"/> Optional module <input type="checkbox"/> Functional Mode Latch, Filter, Fallback ▾ Requires module with software version SV 2.0 or greater </div> <p>Messages</p> <hr/> <p>Device description</p> </div>

Presentation of the Optional Feature for I/O Expansion Modules

I/O expansion modules can be marked as optional in the configuration. The **Optional module** feature provides a more flexible configuration by the acceptance of the definition of modules that are not physically attached to the logic controller. Therefore, a single application can support multiple physical configurations of I/O expansion modules, allowing a greater degree of scalability without the necessity of maintaining multiple application files for the same application.

You must be fully aware of the implications and impacts of marking I/O modules as optional in your application, both when those modules are physically absent and present when running your machine or process. Be sure to include this feature in your risk analysis.

⚠ WARNING

UNINTENDED EQUIPMENT OPERATION

Include in your risk analysis each of the variations of I/O configurations that can be realized marking I/O expansion modules as optional, and in particular the establishment of TM3 Safety modules (TM3S...) as optional I/O modules, and make a determination whether it is acceptable as it relates to your application.

Failure to follow these instructions can result in death, serious injury, or equipment damage.

NOTE: For more details about this feature, refer to *Optional I/O Expansion Modules*, page 57.

Maximum Hardware Configuration

Introduction

The M221 Logic Controller is a control system that offers an all-in-one solution with optimized configurations and an expandable architecture.

Local and Remote Configuration Principle

The following figure defines the local and remote configurations:

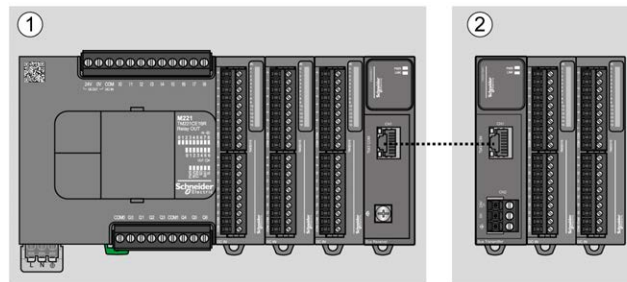

(1) Local configuration

(2) Remote configuration

M221 Logic Controller Local Configuration Architecture

Optimized local configuration and flexibility are provided by the association of:

- M221 Logic Controller
- TM3 expansion modules
- TM2 expansion modules

Application requirements determine the architecture of your M221 Logic Controller configuration.

The following figure represents the components of a local configuration:

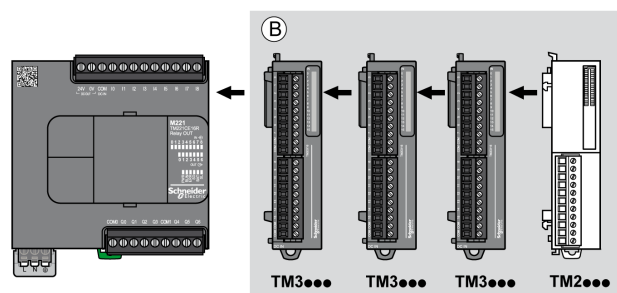

(B) Expansion modules (see maximum number of modules)

NOTE: You cannot mount a TM2 module before any TM3 module as indicated in the following figure:

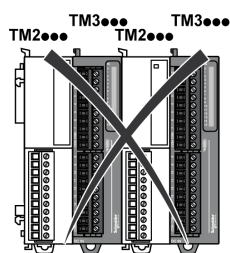

M221 Logic Controller Remote Configuration Architecture

Optimized remote configuration and flexibility are provided by the association of:

- M221 Logic Controller
- TM3 expansion modules
- TM3 transmitter and receiver modules

Application requirements determine the architecture of your M221 Logic Controller configuration.

NOTE: You cannot use TM2 modules in configurations that include the TM3 transmitter and receiver modules.

The following figure represents the components of a remote configuration:

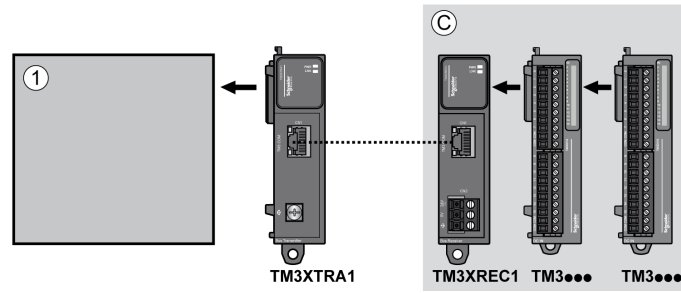

- (1) Logic controller and modules
- (C) Expansion modules (7 maximum)

M221 Logic Controller Distributed Configuration Architecture

Optimized remote configuration and flexibility are provided by the association of:

- M221 Logic Controller
- TM3 bus couplers

This figure shows the components of a distributed architecture:

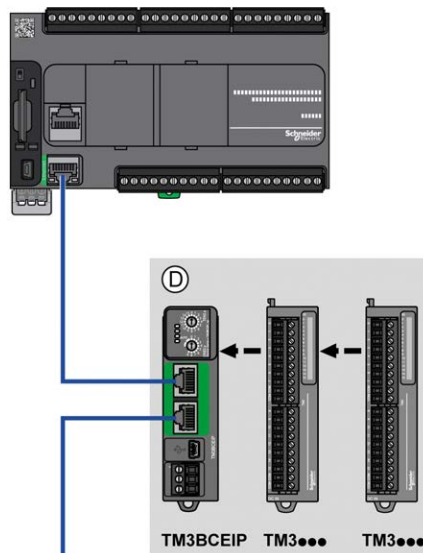

- (D) TM3 distributed modules

Maximum Number of Modules

The following table shows the maximum configuration supported:

References	Maximum	Type of Configuration
TM221C**** TM221M*****	7 TM3 / TM2 expansion modules	Local
TM3XREC1	7 TM3 expansion modules	Remote
TM3BCEIP TM3BCSL	7 TM3 / TM2 expansion modules without transmitter and receiver 14 TM3 expansion modules with transmitter and receiver	Distributed
<p>NOTE: TM3 transmitter and receiver modules are not included in a count of the maximum number of expansion modules.</p>		

NOTE: The configuration with its TM3 and TM2 expansion modules is validated by EcoStruxure Machine Expert - Basic software in the **Configuration** window taking into account the total power consumption of the installed modules.

NOTE: In some environments, the maximum configuration populated by high consumption modules, coupled with the maximum distance allowable between the TM3 transmitter and receiver modules, may present bus communication issues although the EcoStruxure Machine Expert - Basic software allows for the configuration. In such a case you will need to analyze the consumption of the modules chosen for your configuration, as well as the minimum cable distance required by your application, and possibly seek to optimize your choices.

Current Supplied to the I/O Bus

The following table shows the maximum current supplied by the controllers to the I/O Bus:

Reference	IO Bus 5 Vdc	IO Bus 24 Vdc
TM221C16R TM221CE16R	325 mA	120 mA
TM221C16T TM221CE16T	325 mA	148 mA
TM221C16U TM221CE16U	325 mA	148 mA
TM221C24R TM221CE24R	520 mA	160 mA
TM221C24T TM221CE24T	520 mA	200 mA
TM221C24U TM221CE24U	520 mA	200 mA
TM221C40R TM221CE40R	520 mA	240 mA
TM221C40T TM221CE40T	520 mA	304 mA
TM221C40U TM221CE40U	520 mA	304 mA
TM221M16R• TM221ME16R•	520 mA	460 mA
TM221M16T• TM221ME16T•	520 mA	492 mA
TM221M32TK TM221ME32TK	520 mA	484 mA

NOTE: Expansion modules consume current from the 5 Vdc and 24 Vdc supplied to the I/O Bus. Therefore, the current delivered by the logic controller to the I/O Bus defines the maximum number of expansion modules that can be connected to the I/O Bus (validated by EcoStruxure Machine Expert - Basic software in the **Configuration** window).

Configuring Cartridges and Expansion Modules

Introduction

In your project, you can add the following devices to the controller:

- TMC2 Cartridges
- TM3 Digital I/O Modules
- TM3 Analog I/O Modules
- TM3 Expert I/O Modules
- TM2 Digital I/O Modules
- TM2 Analog I/O Modules

TMC2 Cartridges

For more information about cartridge configuration, refer to the following programming and hardware guides:

Cartridge Type	Hardware Guide	Programming Guide
TMC2 Cartridges	TMC2 Cartridges Hardware Guide	TMC2 Cartridges Programming Guide

TM3 Expansion Modules

For more information about module configuration, refer to the following programming and hardware guides of each expansion module type:

Expansion Module Type	Hardware Guide	Programming Guide
TM3 Digital I/O Expansion Modules	TM3 Digital I/O Expansion Modules Hardware Guide	TM3 Expansion Modules Programming Guide
TM3 Analog I/O Expansion Modules	TM3 Analog Modules Hardware Guide	
TM3 Expert I/O Expansion Modules	TM3 Expert I/O Modules Hardware Guide	
TM3 Safety Modules	TM3 Safety Modules Hardware Guide	
TM3 Transmitter and Receiver Modules	TM3 Transmitter and Receiver Modules Hardware Guide	

TM2 Expansion Modules

For more information about module configuration, refer to the programming and hardware guides of each expansion module type:

Expansion Module Type	Hardware Guide	Programming Guide
TM2 Digital I/O Modules	TM2 Digital I/O Modules Hardware Guide	TM2 Expansion Modules Programming Guide
TM2 Analog I/O Modules	TM2 Analog I/O Modules Hardware Guide	

Embedded Communication Configuration

What's in This Chapter

Ethernet Configuration.....	95
Serial Line Configuration.....	122
Supported Modbus Function Codes.....	135
State Machine Diagram for Modbus IOscanner.....	137

Overview

This chapter describes how to configure the communication features of the M221 Logic Controller.

Ethernet Configuration

Configuring Ethernet Network

Introduction

You can configure the TCP/IP connection to the logic controller by configuring the Ethernet network. The Ethernet establishes a local area network (LAN) between the logic controller and other devices. The Ethernet configuration provides you the ability to configure the IP address of the network device.

NOTE: The controller-PC link uses the TCP/IP protocol. It is required for this protocol to be installed on the PC.

You can obtain the IP address by the following protocols:

- Dynamic Host Configuration Protocol (DHCP)
- Bootstrap Protocol (BOOTP)

You can also specify the IP address by specifying the following addresses:

- IP address
- Subnet mask
- Gateway address

NOTE: Schneider Electric adheres to industry best practices in the development and implementation of control systems. This includes a "Defense-in-Depth" approach to secure an Industrial Control System. This approach places the controllers behind one or more firewalls to restrict access to authorized personnel and protocols only.

⚠ WARNING

UNAUTHENTICATED ACCESS AND SUBSEQUENT UNAUTHORIZED MACHINE OPERATION

- Evaluate whether your environment or your machines are connected to your critical infrastructure and, if so, take appropriate steps in terms of prevention, based on Defense-in-Depth, before connecting the automation system to any network.
- Limit the number of devices connected to a network to the minimum necessary.
- Isolate your industrial network from other networks inside your company.
- Protect any network against unintended access by using firewalls, VPN, or other, proven security measures.
- Monitor activities within your systems.
- Prevent subject devices from direct access or direct link by unauthorized parties or unauthenticated actions.
- Prepare a recovery plan including backup of your system and process information.

Failure to follow these instructions can result in death, serious injury, or equipment damage.

Ethernet Services

The logic controller supports the following services:

- Modbus TCP Server
- Modbus TCP Client
- EtherNet/IP Adapter
- Modbus TCP Slave Device

This table presents the maximum number of TCP server connections:

Connection Type	Maximum Number of Connections
Server	8
Client	1

Each server based on TCP manages its own set of connections.

When a client tries to open a connection that exceeds the poll size, the logic controller closes the oldest connection, other than the connection with EcoStruxure Machine Expert - Basic.

The server connections stay open as long as the logic controller stays in its present operational state (*RUNNING*, *STOPPED*, or *HALTED*).

The server connections are closed when a transition is made from its present operational state (*RUNNING*, *STOPPED*, or *HALTED*), except in case of power outage (because the controller does not have time to close the connections).

The server connections can be closed when the EtherNet/IP originator or Modbus TCP Master requests to close.

Ethernet Configuration

This table describes how to configure the Ethernet:

Step	Action
1	<p>Click the ETH1 node in the hardware tree to display the Ethernet properties.</p> <p>This figure presents the Ethernet properties in the editor area:</p> <div data-bbox="459 394 1235 920" style="border: 1px solid #ccc; padding: 10px;"> <p>Ethernet</p> <p>Device name <input type="text" value="M221"/></p> <p> <input type="radio"/> IP address by DHCP <input type="radio"/> IP address by BOOTP <input checked="" type="radio"/> Fixed IP address </p> <p>IP address <input type="text" value="0"/> . <input type="text" value="0"/> . <input type="text" value="0"/> . <input type="text" value="0"/></p> <p>Subnet mask <input type="text" value="0"/> . <input type="text" value="0"/> . <input type="text" value="0"/> . <input type="text" value="0"/></p> <p>Gateway address <input type="text" value="0"/> . <input type="text" value="0"/> . <input type="text" value="0"/> . <input type="text" value="0"/></p> <p>Transfer Rate <input type="button" value="Auto"/></p> <p>Security Parameters</p> <p><input checked="" type="checkbox"/> Programming protocol enabled</p> <p><input checked="" type="checkbox"/> EtherNet/IP protocol enabled</p> <p><input checked="" type="checkbox"/> Modbus server enabled</p> <p><input checked="" type="checkbox"/> Auto discovery protocol enabled</p> </div>
2	<p>Edit the properties to configure the Ethernet.</p> <p>For detailed information on the Ethernet configuration parameters, refer to the table below.</p>

NOTE: The **Security Parameters** displayed depend on the functional level (see EcoStruxure Machine Expert - Basic, Operating Guide) selected for the application.

This table describes each parameter of the Ethernet configuration:

Parameter	Editable	Value	Default Value	Description
Ethernet				
Device name	Yes	<i>any</i>	M221 (if the controller used in the configuration is M221 Logic Controller)	Displays the name of the device that is connected with the Ethernet network. The characters a...z, A...Z, 0...9 and the underscore character (<code>_</code>) are allowed.
IP address by DHCP	Yes ⁽¹⁾	TRUE/FALSE	FALSE	Allows you to obtain the IP address from the DHCP server on the network.
IP address by BOOTP	Yes ⁽¹⁾	TRUE/FALSE	FALSE	Allows you to obtain the IP address from the Boot PROM configuration server on the network.
Fixed IP address	Yes ⁽¹⁾	TRUE/FALSE	TRUE	Allows you to specify the IP address manually for host or network interface identification.
IP address	Yes ⁽²⁾	<i>w.x.y.z⁽³⁾</i>	0.0.0.0	Allows you to specify the IP address of the device in the Ethernet network. See <i>Address Classes</i> , page 100 Assigning 0.0.0.0 (the default) as IP address for the M221 Logic Controller forces the firmware to generate an IP address from the MAC address. The generated IP address is 10.10.XXX.YYY, where XXX and YYY are the decimal values of the last 2 bytes (EE.FF) of the MAC address (AA.BB.CC.DD.EE.FF) Example: MAC address: 00:80:78:19:19:73 EE (19 hex) = 25 decimal FF (73 hex) = 155 decimal IP address generated: 10.10. 25.155 . The firmware also generates an IP address from the MAC address if the specified IP address is identified as being a duplicate address on the network. Bit 9 of system word %SW118 is set to 1 (see <i>System Words Description</i> , page 175) and system word %SW62 is set to 1 (see <i>System Words Description</i> , page 175) when a duplicated IP address is detected. The MAC address of the logic controller is stored in %SW107-%SW109 (see <i>System Words Description</i> , page 175).
Subnet mask	Yes ⁽²⁾	<i>w.x.y.z⁽³⁾</i>	0.0.0.0	Allows you to specify the address of the subnetwork to authorize a group of devices for data exchange. It determines which bits in an IP address correspond to the network address and which bits correspond to the subnet portions of the address. See <i>Subnet Mask</i> , page 100
Gateway address	Yes ⁽²⁾	<i>w.x.y.z⁽³⁾</i>	0.0.0.0	Allows you to specify the IP address of the node (a router) on a TCP/IP network that serves as an access point to another network. See <i>Gateway Address</i> , page 100
Transfer Rate	No	–	Auto	Displays the selected mode for Ethernet speed. Auto stands for "Auto Negotiation".
Security Parameters				
The security parameters allow you to enable or disable communication protocols and features.				
Programming protocol enabled	Yes	TRUE/FALSE	FALSE	Allows you to enable or disable programming via the Ethernet port. Also enables or disables the software object access via animation tables or HMI devices.
EtherNet/IP protocol enabled	Yes	TRUE/FALSE	FALSE	Allows you to enable or disable the EtherNet/IP protocol to connect to a network for data exchange.

Parameter	Editable	Value	Default Value	Description
Modbus server enabled	Yes	TRUE/FALSE	FALSE	Allows you to enable or disable the Modbus TCP server. As a consequence, this enables or disables access to memory objects %M and %MW using standard Modbus requests.
Auto discovery protocol enabled	Yes	TRUE/FALSE	FALSE	Allows you to enable or disable the auto discovery protocol to automatically detect devices on supported Ethernet fieldbusses.

(1) You can select any one option for IP addressing. Selecting any one option disables the other options.

(2) These options are enabled only if you select the option **Fixed IP Address** for IP addressing.

(3) w, x, y, and z are the bytes that store the address and each byte can store a value in the range 0...255.

NOTE: When a protocol listed in **Security Parameters** is disabled, requests from the corresponding server type are ignored. The corresponding configuration screen remains accessible; however, program execution is not affected.

Address Management

This diagram presents the different types of address systems for the M221 Logic Controller:

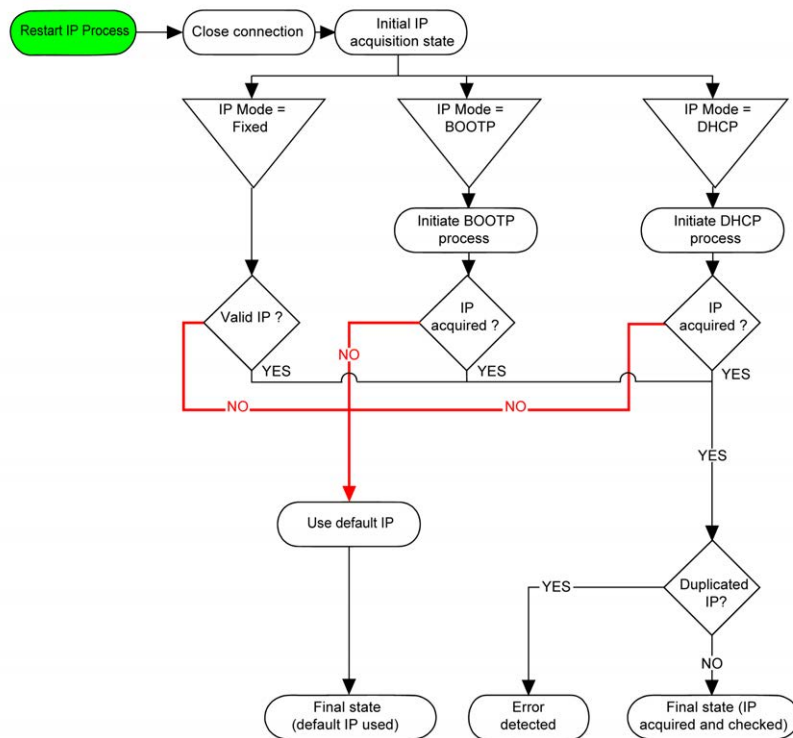

NOTE: If a device programmed to use the DHCP or BOOTP addressing methods is unable to contact its respective server, the controller uses the default IP address. It will, however, constantly repeat its request.

The IP process restarts in the following cases:

- Controller reboot
- Ethernet cable reconnection
- Application download (if IP parameters change)
- DHCP or BOOTP server detected after a prior addressing attempt was unsuccessful or when the DHCP address lease expires.

Address Classes

The IP address is linked:

- to a device (the host)
- to the network to which the device is connected

An IP address is always coded using 4 bytes.

The distribution of these bytes between the network address and the device address may vary. This distribution is defined by the address classes.

The different IP address classes are defined in this table:

Address Class	Byte 1			Byte 2	Byte 3	Byte 4	
Class A	0	Network ID			Host ID		
Class B	1	0	Network ID			Host ID	
Class C	1	1	0	Network ID			Host ID
Class D	1	1	1	0	Multicast Address		
Class E	1	1	1	1	0	Address reserved for subsequent use	

Subnet Mask

The subnet mask is used to address several physical networks with a single network address. The mask is used to separate the subnetwork and the device address in the host ID.

The subnet address is obtained by retaining the bits of the IP address that correspond to the positions of the mask containing 1, and replacing the others with 0.

Conversely, the subnet address of the host device is obtained by retaining the bits of the IP address that correspond to the positions of the mask containing 0, and replacing the others with 1.

Example of a subnet address:

IP address	192 (11000000)	1 (00000001)	17 (00010001)	11 (00001011)
Subnet mask	255 (11111111)	255 (11111111)	240 (11110000)	0 (00000000)
Subnet address	192 (11000000)	1 (00000001)	16 (00010000)	0 (00000000)

NOTE: The device does not communicate on its subnetwork when there is no gateway.

Gateway Address

The gateway allows a message to be routed to a device that is not on the current network.

If there is no gateway, the gateway address is 0.0.0.0.

Configuring Modbus TCP or Modbus TCP IOScanner

Introduction

You can configure the Ethernet port for Modbus TCP or Modbus TCP IOScanner as:

- Modbus, page 101
- Client mode, page 103

Only one instance of IOScanner can be defined: if you configure it on a serial port, you cannot configure it on an Ethernet port and vice versa. Refer to [Configuring Modbus Serial IOScanner](#), page 128.

The maximum number of TCP and Serial IOScanner objects depends on the functional level. For more information, refer to .

If a communication interruption occurs, the IOScanner stops. For more information on the status, page 175, refer to %SW212.

Use the following system bits to reset or suspend the Modbus TCP IOScanner (refer to [System Bits Description](#), page 168): %S112 and %S115.

Configuring Modbus TCP: Modbus Mapping

This table describes how to configure Modbus mapping:

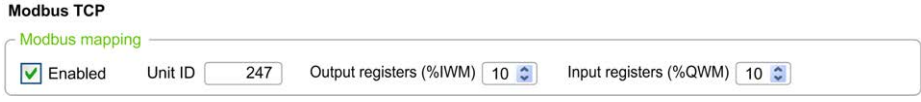
Step	Action
1	<p>In the Configuration window, click ETH1→ Modbus TCP to display the Modbus TCP properties.</p> <p>The following illustration shows the properties displayed in the editor area:</p> 
2	<p>Select Enabled to edit the properties to configure Modbus mapping.</p> <p>NOTE: If the Enabled button is grayed out, verify that the Functional Level of your application (Programming > Tasks > Behavior tab) is at least Level 3.2.</p>
3	Click Apply .

This table describes each parameter of the **Modbus mapping** configuration:

Parameter	Editable ⁽¹⁾	Value	Default Value	Description
Enabled	Yes	TRUE/FALSE	FALSE	Select to enable Modbus mapping . NOTE: If you deselect the Enabled check box, and you have used network variables in your program, they are no longer valid and your program can no longer be compiled. If you wish to temporarily disable the Modbus TCP/IP services without invalidating the use of its network variables, you can deactivate the Security Parameters for the protocol in the Ethernet properties window, page 95.
Unit ID	Yes	1...247	-	Specify the unit ID of the local server. Modbus TCP requests originating from a device with the same unit ID are sent to the Modbus mapping table instead of the regular Modbus server.
Output registers (%IWM)	Yes	1...20	10	The number of output registers available. Output registers are used to store the values of Modbus TCP (%IWM) objects, page 160.
Input registers (%QWM)	Yes	1...20	10	The number of input registers available. Input registers are used to store the values of Modbus TCP (%QWM) objects, page 159.
⁽¹⁾ Only if the Modbus server enabled option is selected in the Security Parameters section of the Ethernet properties windows, page 99.				

Modbus TCP Slave Device I/O Mapping Table

When the Modbus TCP slave device has been configured, Modbus commands sent to its unit ID (Modbus address) access network objects (%IWM and %QWM) of the controller, instead of the regular Modbus words accessed when the unit ID is 255. This facilitates read/write operations by a Modbus master I/O scanner application.

If the unit ID selected in the master is not the one configured in the M221 slave (or vice versa), data is read or written to regular Modbus words %MWx instead of network objects %IWMx and %QWMx. No Modbus error is returned.

Access to the Modbus TCP slave I/O mapping table (%IWM/%QWM) is done with the same priority as access to regular Modbus words (%MW).

The Modbus TCP slave device responds to a subset of the Modbus function codes, but does so in a way that differs from Modbus standards, with the purpose of exchanging data with the external I/O scanner. The following Modbus function codes are supported by the Modbus TCP slave device:

Function Code Dec (Hex)	Function	Comment
3 (3 hex)	Read output register	Allows the master I/O scanner to read network object %QWM of the device
4 (4 hex)	Read input registers	Allows the master I/O scanner to read network object %IWM of the device
6 (6 hex)	Write single register	Allows the master I/O scanner to write a single network object %IWM of the device
16 (10 hex)	Write multiple registers	Allows the master I/O scanner to write to multiple network objects %IWM of the device
23 (17 hex)	Read/write multiple registers	Allows the master I/O scanner to read network object %QWM and write network object %IWM of the device

Configuring Modbus TCP: Client Mode

This table describes how to configure client mode:

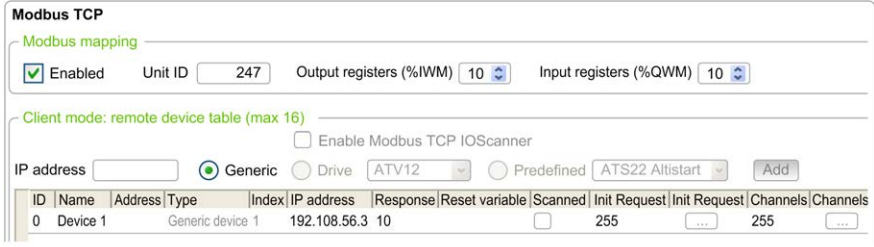
Step	Action
1	<p>In the Configuration window, click ETH1 → Modbus TCP to display the Modbus TCP properties.</p> <p>The following illustration shows the properties displayed in the editor area:</p> 
2	Add a remote device. Refer to <i>Adding Remote Devices</i> , page 103.
3	<p>If you want to configure Modbus TCP IOScanner, select Enable Modbus TCP IOScanner.</p> <p>NOTE: If the Enable Modbus TCP IOScanner button is grayed out, verify that the Functional Level of your application (Programming > Tasks > Behavior tab) is at least Level 6.0 and that there is no instance configured in Serial line > Modbus Serial IOScanner.</p> <p>You can configure and add remote devices for Modbus TCP even if Modbus TCP IOScanner is enabled.</p>

Adding Remote Devices

The following table describes the parameters of **Client mode: remote device table (max 16)** to add a device:

Parameter	Editable ⁽¹⁾	Value	Default Value	Description
IP address	Yes	w.x.y.z ⁽²⁾	–	Allows you to specify the IP address of the device to add. Also, refer to <i>Adding Remote Devices</i> .
Generic Drive Predefined	Yes	Selection	Generic	Allows you to select the type of device to add. Drive and Predefined are available if Modbus TCP IOScanner is enabled. NOTE: TM3 bus couplers are part of Predefined .



⁽¹⁾ Only if the **Modbus server enabled** option is selected in the **Security Parameters** section of the Ethernet properties window, page 95.

⁽²⁾ w, x, y, and z are the bytes that store the address and each byte can store a value in the range.

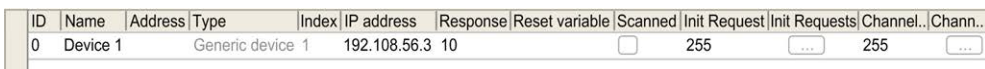
This table describes how to add a remote device:

Step	Action
1	Enter the IP address in the IP address field.
2	<p>Select Generic, Drive, or Predefined.</p> <p>Drive and Predefined are only enabled if Enable Modbus TCP IOScanner is selected.</p>
3	<p>Click the Add button.</p> <p>The Add button is disabled if:</p> <ul style="list-style-type: none"> The maximum of 16 devices is already configured. The IP address is in an incorrect format. <p>Result: A list of remote devices that you have added appears on the screen.</p> 
4	Click Apply .

This table describes each column of the table listing the remote devices:

Parameter	Editable	Value	Default Value	Description
ID	No	0...15	0	Unique device identifier assigned by EcoStruxure Machine Expert - Basic.
Name	Yes	1...32 characters The device name must be unique.	Device x ⁽¹⁾	The name of the device.
Address	No	– %DRVn ⁽²⁾	– %DRVn	%DRVn is used to configure the device in the application using Drive function blocks.
Type	No	Type of the device	–	To change the device type, you must remove the device from the list (by right-clicking and choosing Delete), then add the correct device type.
Index	No	1...16	–	The index number of the devices which are remotely connected.
IP address	Yes	w.x.y.z ⁽²⁾	–	Address used to identify the device within the network. Duplicate slave addresses are allowed.
Response timeout (x 100 ms)	Yes	0...65535	10	The connection timeout duration. The period of time (in units of 100 ms) during which the controller attempts to establish a TCP connection to the remote device. At the end of this period, if a TCP connection is still not established, the controller stops connection attempts until the next connection request with an EXCH instruction.
Reset variable	Yes	%Mn	–	Specify the address of the memory bit to use to reset the device (re-send the initialization requests). When the specified memory bit is set to 1 by the application, the device is reset.
Scanned	No	TRUE/FALSE	TRUE	Allows to see which device is configured for Modbus TCP IOScanner.
Init Request Unit ID	Yes	0...255	255	Specify the unit ID of the local device. Modbus TCP requests originating from a device with the same unit ID are sent to the Modbus mapping table instead of the regular Modbus server.
Init. requests ⁽³⁾	Yes		–	Click to display the Initialization request assistant window, page 104.
Channels Unit ID	Yes	0...255	255	Specify the unit ID of the local device. Modbus TCP requests originating from a device with the same unit ID are sent to the Modbus mapping table instead of the regular Modbus server.
Channels ⁽³⁾	Yes		–	Click to display the Channel assistant window, page 106.

⁽¹⁾ w, x, y, and z are the bytes that store the address and each byte can store a value in the range 0...255.
⁽²⁾ x and n are integers respectively incremented each time a device or a drive device is added.
⁽³⁾ Enabled if **Modbus Serial IOScanner** is not configured in **Serial line** node → **Protocol Settings**.

Configuring Initialization Requests

Initialization requests are device-specific commands sent by the Modbus TCP IOScanner or Modbus Serial IOScanner to initialize a slave device. The Modbus TCP IOScanner or Modbus Serial IOScanner does not start cyclic data exchange with the device until all its initialization requests have been acknowledged by the device. During the initialization phase, network objects are not updated.

Up to 20 initialization requests can be defined for each slave device.

The **Initialization request assistant** window presents the defined initialization requests:

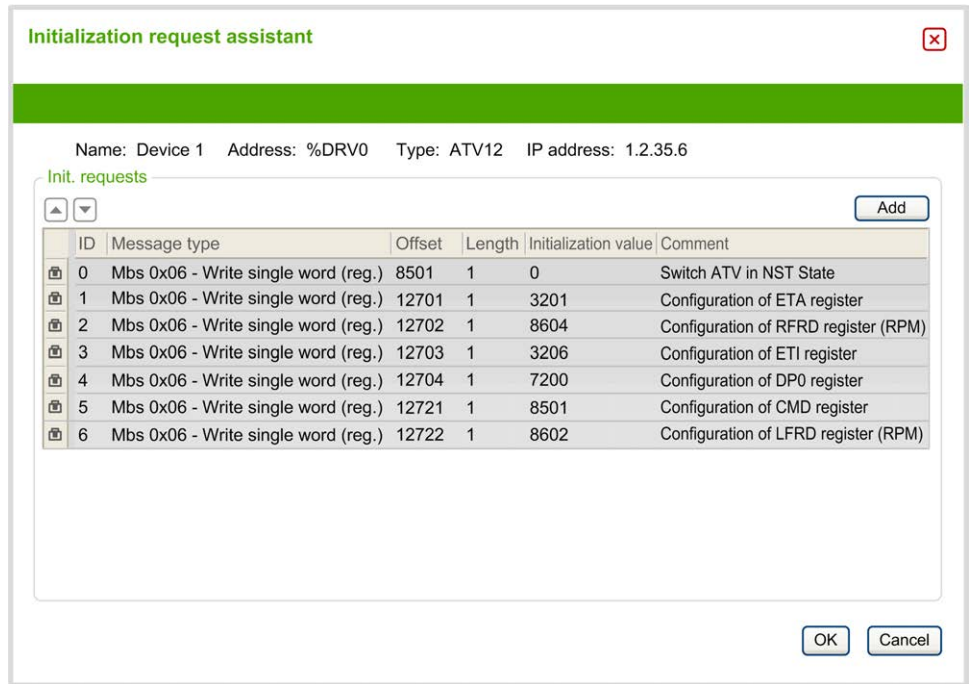

Preconfigured initialization requests are displayed with a lock symbol  and a gray background. Some parameters cannot be modified for predefined initialization requests.

According to the device type that you selected, some initialization requests may be configured.

This table describes the properties of initialization requests:

Parameter	Editable	Value	Default Value	Description
ID	No	0...19	0	Unique initialization request identifier.
Message type	Yes, if initialization request is not predefined.	See Supported Modbus Function Codes, page 136	Mbs 0x05 - Write single bit (coil)	Select the Modbus function code for the type of exchange to use for this initialization request. NOTE: If configuring a generic device that does not support the default Mbs 0x05 - Write single bit (coil) request type, you must replace the default value with a supported request type.
Offset	Yes, if initialization request is not predefined.	0...65535	0	Offset of the first register to initialize.
Length	Yes, if initialization request is not predefined.	1 for Mbs 0x05 - Write single bit (coil) 1 for Mbs 0x06 - Write single word (register) 128 for Mbs 0x0F - Write multiple bits (coils) 123 for Mbs 0x10 - Write multiple words (reg.)	1	Number of objects (memory words or bits) to be initialized. For example, if writing multiple words with Offset = 2 and Length = 3 , %MW2 , %MW3 , and %MW4 are initialized.
Initialization value	Yes, if initialization request is not predefined.	0...65535 if memory words (registers) are being initialized 0...1 if memory bits (coils) are being initialized	0	Value to initialize the targeted registers with.
Comment	Yes, if initialization request is not predefined.	-	Empty	Optionally, type a comment to associate with this request.

Click **Add** to create new initialization requests.

Select an entry then use the up arrow and down arrow buttons to change the order in which the initialization requests are sent to the device.

When the initialization requests have been defined, click **OK** to save the configuration and close the **Initialization request assistant**.

Channel Assistant

Up to 10 channels can be defined for each slave device. Each channel represents a single Modbus request.

NOTE: The number of objects defined (items of data read and written) is validated when you click **Apply** on the properties window.

The **Channel assistant** window lists the defined channels:

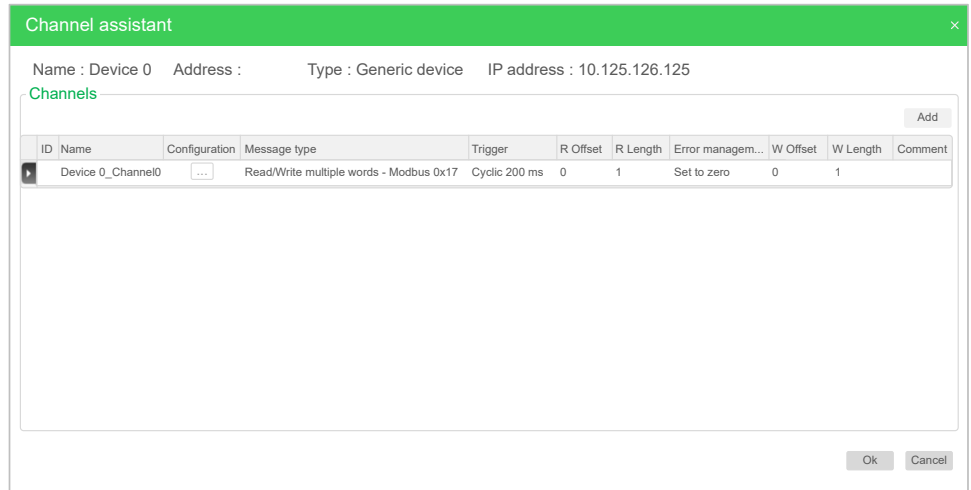

Click on **Configuration**  (1) to display the **Channel assistant** window detail (2):

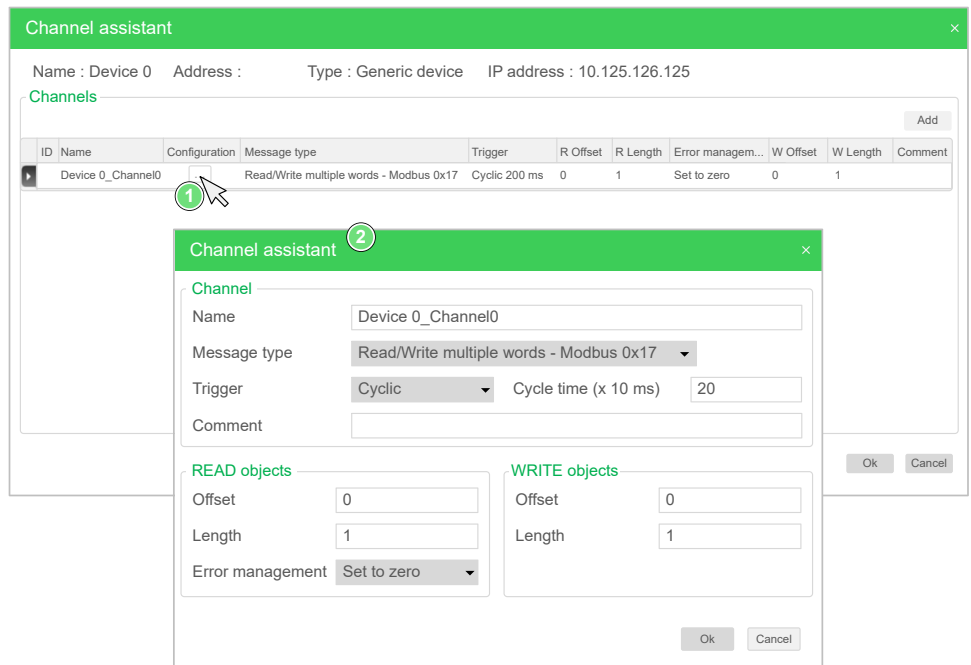

Preconfigured channels are displayed with a lock symbol  and a gray background. Some parameters cannot be modified for predefined channels.

This table describes the properties of channels:

Parameter	Editable	Value	Default Value	Description
ID	No	0...19	0	Unique initialization identifier.
Name	Yes	0...32 characters	Device_channel0	Double-click to edit the name of the channel.
Configuration	Yes		-	Click to display the Channel assistant detail window.
Message type	No	-	-	The Modbus function code that was selected in the Channel assistant detail window.
Trigger	No	-	-	The trigger type and cycle time that was selected in the Channel assistant detail window.
R Offset	No	-	-	The READ object offset that was selected in the Channel assistant detail window.
R Length	No	-	-	The READ object length that was selected in the Channel assistant detail window.
Error management	No	-	-	The error management policy that was selected in the Channel assistant detail window.
W Offset	No	-	-	The WRITE object offset that was selected in the Channel assistant detail window.
W Length	No	-	-	The WRITE object length that was selected in the Channel assistant detail window.
Comment	Yes	-	Empty	Optionally, type a comment to associate with this channel.

Click **Add** to create a new channel.

When the channels have been defined, click **OK** to save the configuration and close the **Channel assistant**.

Configuring Channels

Use the **Channel assistant** detail window to configure channels.

The following example shows a channel configured for a Read/Write Multiple Words request (Modbus function code 23). It reads one word from the register with offset 16#0C21 and writes two words to the register with offset 16#0C20. This request is executed when there is a rising edge of the defined **Trigger** (see graphic below):

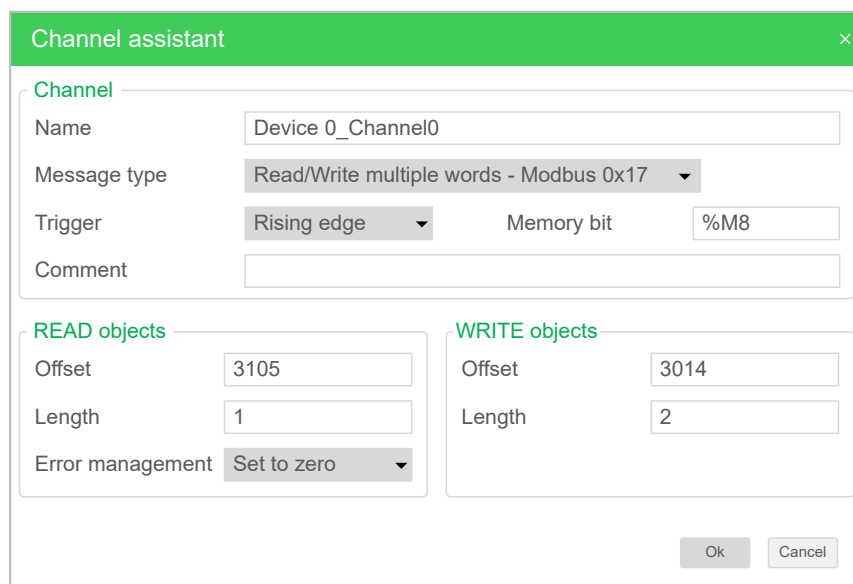

This table describes the properties of channels:

Parameter	Editable	Value	Default Value	Description
Name	Yes	0...32 characters	Device 0_Channel0	Enter a name for the channel.
Message type	Yes	See Supported Modbus Function Codes, page 136	Mbs 0x17 - Read/Write mult. words (reg.)	Select the Modbus function code for the type of exchange to use on this channel.
Trigger	Yes	Cyclic Rising edge	Cyclic	Choose the trigger type for the data exchange: <ul style="list-style-type: none"> • Cyclic: The request is triggered with the frequency defined in the Cycle Time (x 10 ms) field • Rising edge: The request is triggered upon detection of a rising edge of a memory bit. Specify the address of the Memory bit to use.
Cycle time (x 10 ms) (If Cyclic is selected)	Yes	1...6000	20	Specify the periodic trigger cycle time, in units of 10 ms.
Memory bit (If Rising edge is selected)	Yes	%Mn	-	Specify a memory bit address, for example, %M8. The data exchange is triggered when a rising edge of this memory bit is detected.
Comment	Yes	-	Empty	Optionally, type a comment to describe the purpose of the channel.
READ objects				
Offset	Yes	0...65535	0	Address of the first memory word (register) or bit (coil) to read.
Length	Yes	See Supported Modbus Function Codes, page 136 for maximum length	-	Number of memory words (registers) or bits (coils) to read.
Error management	Yes	Set to zero Retain last value	Set to zero	Specify how to manage the situation when data can no longer be read from the device: <ul style="list-style-type: none"> • Select Set to zero to set the last data values received to zero. • Select Retain last value to keep the last data values received.
WRITE objects				
Offset	Yes	0...65535	0	Address of the first memory word (register) or bit (coil) to write.
Length	Yes	See Supported Modbus Function Codes, page 136 for maximum length	-	Number of memory words (registers) or bits (coils) to write.

Click **OK** to complete channel configuration.

Configuring EtherNet/IP

Introduction

This section describes the configuration of the EtherNet/IP connection to the controller.

For further information about EtherNet/IP, refer to www.odva.org.

EtherNet/IP Adapter Configuration

The following table describes how to display the EtherNet/IP Adapter configuration window:

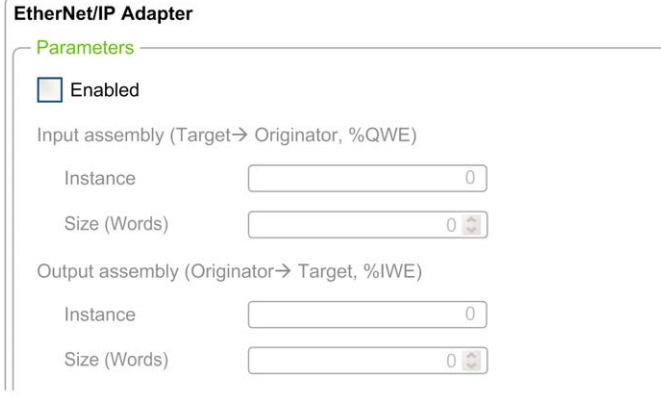
Step	Action
1	<p>Click the EtherNet/IP adapter node that appears below the ETH1 node in the hardware tree.</p> <p>This figure presents the properties of the EtherNet/IP Adapter in the editor area:</p> 
2	<p>Select Enabled to edit the properties to configure the EtherNet/IP Adapter.</p> <p>NOTE: If the Enabled button is grayed out, verify that the Functional Level of your application (Programming > Tasks > Behavior tab) is at least Level 3.2.</p> <p>For detailed information on the EtherNet/IP Adapter configuration parameters, refer to the table below.</p>
3	Click Apply .

EtherNet/IP Adapter Properties

This table describes each parameter of the EtherNet/IP Adapter configuration:

Parameter	Editable	Value	Default Value	Description
Enabled	Yes	TRUE/FALSE	FALSE	<p>Select to enable the EtherNet/IP Adapter configuration.</p> <p>NOTE: If you deselect the Enabled check box, and you have used network variables in your program, they are no longer valid and your program can no longer be compiled. If you wish to temporarily disable the EtherNet/IP Adapter services without invalidating the use of its network variables, you can deactivate the Security Parameters for the protocol in the Ethernet properties window, page 95.</p> <p>When disabled, by deselecting the Enabled checkbox, configured fallback values, page 157 of %QWE objects, as well as symbols and comments, are lost.</p>
Input assembly (Target ->Originator, %QWE)				
Instance	Yes	1...255	100	The identifier of the Input assembly.
Size (words)	Yes	1...20	20	The size of the Input assembly.
Output assembly (Originator->Target, %IWE)				
Instance	Yes	1...255	150	The identifier of the Output assembly.
Size (words)	Yes	1...20	20	The size of the Output assembly.

NOTE: Output means output from the Scanner controller (%IWE for the Adapter).

Input means input from the Scanner controller (%QWE for the Adapter).

The following graphic presents the directionality of Input assembly and Output assembly in EtherNet/IP communications:

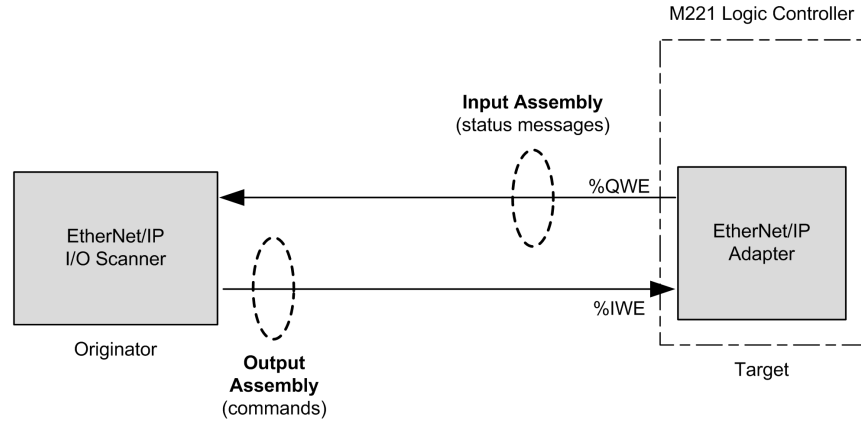

EDS File

A template electronic data sheet (EDS) file, **M221_EDS_Model.eds**, is provided in *EcoStruxure Machine Expert - Basic installation folder\Firmwares & PostConfiguration*.

Modify the file as described in the user guide to be found in the same folder.

Profile

The controller supports the following objects:

Object class	Class ID (hex)	Cat.	Number of Instances	Effect on Interface Behavior
Identity Object, page 112	01	1	1	Provides the identification of the device and general information about it. Supports the reset service.
Message Router Object, page 114	02	1	1	Provides a message connection that allows the client to address a service to any object class or instance residing in the device.
Assembly Object, page 116	04	2	2	Binds attributes of multiple objects, which allows data to or from each object to be sent or received over a single connection.
Connection Manager Object, page 118	06	–	1	Manages the characteristics of a communication connection.
TCP/IP Interface Object, page 119	F5	1	1	Provides the mechanism to configure the TCP/IP network interface of a device.
Ethernet Link Object, page 121	F6	1	1	Maintains link specific counters and status information for an IEEE 802.3 communication interface.

Identity Object (Class ID = 01 hex)

The following table describes the class attributes of the Identity Object (Instance 0):

Attribute ID	Access	Name	Data Type	Value (hex)	Details
1	Get	Revision	UINT	01	Implementation revision of the Identity Object
2	Get	Max Instances	UINT	01	The largest instance number
3	Get	Number of Instances	UINT	01	The number of object instances
4	Get	Optional Instance Attribute List	UINT, UINT []	00	The first 2 bytes contain the number of optional instance attributes. Each following pair of bytes represents the number of other optional instance attributes.
6	Get	Max Class Attribute	UINT	07	The largest class attributes value
7	Get	Max Instance Attribute	UINT	07	The largest instance attributes value

The following table describes the Class Services:

Service Code (hex)	Name	Description
01	Get Attribute All	Returns the value of all class attributes
0E	Get Attribute Single	Returns the value of the specified attribute

The following table describes the Instance Services:

Service Code (hex)	Name	Description
01	Get Attribute All	Returns the value of all class attributes
05	Reset ⁽¹⁾	Initializes EtherNet/IP component (controller reboot)
0E	Get Attribute Single	Returns the value of the specified attribute

(1) Reset Service description:

When the Identity Object receives a Reset request, it:

- determines whether it can provide the type of reset requested
- responds to the request
- attempts to perform the type of reset requested

The Reset common service has one specific parameter, Type of Reset (USINT), with the following values:

Value	Type of Reset
0	Reboot the controller NOTE: This value is the default value if this parameter is omitted.
1	Reset Warm
2	Not supported
3...99	Reserved
100...199	Not used
200...255	Reserved

The following table describes the Instance attributes:

Attribute ID	Access	Name	Data Type	Value (hex)	Details
1	Get	Vendor ID	UINT	F3	Schneider Automation identifier
2	Get	Device type	UINT	0E	Device is a logic controller
3	Get	Product code	UINT	1003	M221 Logic Controller product code
4	Get	Revision	Struct of USINT, USINT	–	Product revision of the controller. ⁽¹⁾ Equivalent to the 2 low bytes of the controller version. Example: For the M221 Logic Controller firmware version 1.3.2.0, the value read is 1.3
5	Get	Status	WORD ⁽¹⁾	–	See definition in the table below
6	Get	Serial number	UDINT	–	Serial number of the controller XX + 3 least significant bytes of the MAC address
7	Get	Product name	Struct of USINT, STRING	–	Maximum length is 32. Example: TM221CE16T

(1) Mapped in a WORD:

- MSB: minor revision (second USINT)
- LSB: major revision (first USINT)

Status Description (Attribute 5):

Bit	Name	Description
0	Owned	Unused
1	Reserved	–
2	Configured	TRUE indicates the device application has been reconfigured.
3	Reserved	–
4...7	Extended Device Status	<ul style="list-style-type: none"> 0: self-testing or undetermined 1: firmware update in progress 2: at least one invalid I/O connection error detected 3: no I/O connections established 4: non-volatile configuration invalid 5: non recoverable error detected 6: at least one I/O connection in RUNNING state 7: at least one I/O connection established, all in idle mode 8: reserved 9...15: unused
8	Minor Recoverable Error	TRUE indicates the device detected an error, which, under most circumstances, is recoverable. This type of event does not lead to a change in the device state.
9	Minor Unrecoverable Error	TRUE indicates the device detected an error, which, under most circumstances, is not recoverable. This type of event does not lead to a change in the device state.
10	Major Recoverable Error	TRUE indicates the device detected an error, which requires the device to report an exception and enter into the HALT state. This type of event leads to a change in the device state, but, under most circumstances, is recoverable.
11	Major Unrecoverable Error	TRUE indicates the device detected an error, which requires the device to report an exception and enter into the HALT state. This type of event leads to a change in the device state, but, under most circumstances is not recoverable.
12...15	Reserved	–

Message Router Object (Class ID = 02 hex)

The following table describes the class attributes of the Message Router Object (Instance 0):

Attribute ID	Access	Name	Data Type	Value (hex)	Details
1	Get	Revision	UINT	01	Implementation revision of the Message Router Object
2	Get	Max Instances	UINT	01	The largest instance number
3	Get	Number of Instance	UINT	01	The number of object instances
4	Get	Optional Instance Attribute List	Struct of UINT, UINT []	–	The first 2 bytes contain the number of optional instance attributes. Each following pair of bytes represents the number of other optional instance attributes (from 100 to 119).
5	Get	Optional Service List	UINT	00	The number and list of any implemented optional services attribute (0: no optional services implemented)
6	Get	Max Class Attribute	UINT	07	The largest class attributes value
7	Get	Max Instance Attribute	UINT	77	The largest instance attributes value

NOTE: Use instance 0 to read the Class Attributes information.

The following table describes the Class Services:

Service Code (hex)	Name	Description
01	Get Attribute All	Returns the value of all class attributes
0E	Get Attribute Single	Returns the value of the specified attribute

The following table describes the Instance Services (Instance 1):

Service Code (hex)	Name	Description
01	Get Attribute All	Returns the value of all class attributes
0E	Get Attribute Single	Returns the value of the specified attribute

The following table describes the Instance attributes:

Attribute ID	Access	Name	Data Type	Value (hex)	Description
1	Get	Implemented Object List	Struct of UINT, UINT []	–	Implemented Object list. The first 2 bytes contain the number of implemented objects. Each following pair of bytes represents another implemented class number. This list contains the following objects: <ul style="list-style-type: none"> • 01: Identity • 02: Message Router • 04: Assembly • 06: Connection Manager • F5: TCP/IP • F6: Ethernet Link
2	Get	Number available	UINT	08	Maximum number of concurrent CIP (Class 1 or Class 3) connections supported
100	Get	Total incoming Class1 packets received during the last second	UINT	–	Total number of incoming packets received for all implicit (Class 1) connections during the last second
101	Get	Total outgoing Class1 packets sent during the last second	UINT	–	Total number of outgoing packets sent for all implicit (Class 1) connections during the last second
102	Get	Total incoming Class3 packets received during the last second	UINT	–	Total number of incoming packets received for all explicit (Class 3) connections during the last second
103	Get	Total outgoing Class3 packets sent during the last second	UDINT	–	Total number of outgoing packets sent for all explicit (Class 3) connections during the last second
104	Get	Total incoming unconnected packets received during the last second	UINT	–	Total number of incoming unconnected packets received during the last second
105	Get	Total outgoing unconnected packets sent during the last second	UINT	–	Total number of outgoing unconnected packets sent during the last second
106	Get	Total incoming EtherNet/IP packets received during the last second	UINT	–	Total unconnected Class 1 or Class 3 packets received during the last second
107	Get	Total outgoing EtherNet/IP packets sent during the last second	UINT	–	Total unconnected Class 1 or Class 3 packets sent during the last second
108	Get	Total incoming Class1 packets received	UINT	–	Total number of incoming packets received for all implicit (Class 1) connections
109	Get	Total outgoing Class1 packets sent	UINT	–	Total number of outgoing packets sent for all implicit (Class 1) connections
110	Get	Total incoming Class3 packets received	UINT	–	Total number of incoming packets received for all explicit (Class 3) connections. This number includes the packets that would be returned if an error had been detected (listed in the next two rows).
111	Get	Total incoming Class3 packets Invalid Parameter Value	UINT	–	Total number of incoming Class 3 packets that targeted an unsupported service/class/instance/attribute/member
112	Get	Total incoming Class3 packets Invalid Format	UINT	–	Total number of incoming Class 3 packets that had an invalid format

Attribute ID	Access	Name	Data Type	Value (hex)	Description
113	Get	Total outgoing Class3 packets sent	UINT	–	Total number of packets sent for all explicit (Class 3) connections
114	Get	Total incoming unconnected packets received	UINT	–	Total number of incoming unconnected packets. This number includes the packets that would be returned if an error had been detected (listed in the next two rows).
115	Get	Total incoming unconnected packets Invalid Parameter Value	UINT	–	Total number of incoming unconnected packets that targeted an unsupported service/class/instance/attribute/member
116	Get	Total incoming unconnected packets Invalid Format	UINT	–	Total number of incoming unconnected packets that had an invalid format
117	Get	Total outgoing unconnected packets sent	UINT	–	Total number of all unconnected packets sent
118	Get	Total incoming EtherNet/IP packets	UINT	–	Total number of unconnected (Class 1) or Class 3 packets received
119	Get	Total outgoing EtherNet/IP packets	UINT	–	Total number of unconnected (Class 1) or Class 3 packets sent

Assembly Object (Class ID = 04 hex)

The following table describes the class attributes of the Assembly Object (Instance 0):

Attribute ID	Access	Name	Data Type	Value (hex)	Details
1	Get	Revision	UINT	02	Implementation revision of the Assembly Object
2	Get	Max Instances	UINT	–	The largest instance number of created objects of this class. Example: If input instances = 200, output instances = 100, this attribute returns 200.
3	Get	Number of Instances	UINT	02	The number of object instances
4	Get	Optional Instance Attribute List	Struct of: UINT UINT []	–	The first 2 bytes contain the number of optional instance attributes. Each following pair of bytes represents the number of other optional instance attributes.
5	Get	Optional Service List	UINT	00	The number and list of any implemented optional services attribute (0: no optional services implemented)
6	Get	Max Class Attribute	UINT	07	The largest class attributes value
7	Get	Max Instance Attribute	UINT	04	The largest instance attributes value

The following table describes the Class Services:

Service Code (hex)	Name	Description
0E	Get Attribute Single	Returns the value of the specified attribute

The following table describes the Instance Services:

Service Code (hex)	Name	Description
0E	Get Attribute Single	Returns the value of the specified attribute
10	Set Attribute Single	Modifies the value of the specified attribute
18	Get Member	Reads a member of an Assembly object instance
19	Set Member	Modifies a member of an Assembly object instance

Instances Supported

Output means OUTPUT from Originator controller (= %IWE for the M221 Logic Controller).

Input means INPUT from Originator controller (= %QWE for the M221 Logic Controller).

The controller supports 2 Assemblies:

Name	Instance	Data Size
Input Assembly (EtherNet/IP) (%QWE)	Configurable from 1...255	1...20 words
Output Assembly (EtherNet/IP) (%IWE)	Configurable from 1...255	1...20 words

NOTE: The Assembly object binds together the attributes of multiple objects so that information sent to or received from each object can be communicated over a single connection. Assembly objects are static.

The assemblies in use can be modified through the parameter access of the network configuration tool (RSNetWorx). You must perform a power cycle of the logic controller to register a new assembly assignment.

The following table describes the Instance attributes:

Attribute ID	Access	Name	Data Type	Value	Description
1	Get	Number of Member Object List	UINT	1...20	Number of members for this assembly
2	Get	Member List	ARRAY of Struct	–	Array of 1 structure where each structure represents one member
3	Get/Set	Instance Data	ARRAY of Byte	–	Data Set service only available for Controller output
4	Get	Instance Data Size	UINT	2...40	Size of data in bytes

Member list content:

Name	Data Type	Value	Type of Reset
Member data size	UINT	4...40	Member data size in bits
Member path size	UINT	6	Size of the EPATH (see table below)
Member path	EPATH	–	EPATH to the Member

EPATH is:

Word	Value (hex)	Semantic
0	2004	Class 4
1	24xx	Instance xx, where xx is the instance value (for example: 2464 hex = instance 100)
2	xxxx	See the Common Industrial Protocol Specification Volume 1 - Appendix C for the format of this field

Connection Manager Object (Class ID = 06 hex)

The following table describes the class attributes of the Assembly Object (Instance 0):

Attribute ID	Access	Name	Data Type	Value (hex)	Details
1	Get	Revision	UINT	01	Implementation revision of the Connection Manager Object
2	Get	Max Instances	UINT	01	The largest instance number
3	Get	Number of Instances	UINT	01	The number of object instances
4	Get	Optional Instance Attribute List	Struct of: UINT UINT []	–	The number and list of the optional attributes. The first word contains the number of attributes to follow and each following word contains another attribute code. Following optional attributes include: <ul style="list-style-type: none"> • Total number of incoming connection open requests • The number of requests rejected because of the non-conforming format of the Forward Open • The number of requests rejected because of insufficient resources • The number of requests rejected because of the parameter value sent with the Forward Open • The number of Forward Close requests received • The number of Forward Close requests that had an invalid format • The number of Forward Close requests that could not be matched to an active connection • The number of connections that have timed out because the other side stopped producing, or a network disconnection occurred
6	Get	Max Class Attribute	UINT	07	The largest class attributes value
7	Get	Max Instance Attribute	UINT	08	The largest instance attributes value

The following table describes the Class Services:

Service Code (hex)	Name	Description
01	Get Attribute All	Returns the value of all class attributes
0E	Get Attribute Single	Returns the value of the specified attribute

The following table describes the Instance Services:

Service Code (hex)	Name	Description
01	Get Attribute All	Returns the value of all instance attributes
0E	Get Attribute Single	Returns the value of the specified attribute
4E	Forward Close	Closes an existing connection
52	Unconnected Send	Sends a multi-hop unconnected request
54	Forward Open	Opens a new connection

The following table describes the Instance attributes (Instance 1):

Attribute ID	Access	Name	Data Type	Value	Description
1	Get	Open Requests	UINT	–	Number of Forward Open service requests received
2	Get	Open Format Rejects	UINT	–	Number of Forward Open service requests which were rejected due to invalid format
3	Get	Open Resource Rejects	UINT	–	Number of Forward Open service requests which were rejected due to lack of resources
4	Get	Open Other Rejects	UINT	–	Number of Forward Open service requests which were rejected for reasons other than invalid format or lack of resources
5	Get	Close Requests	UINT	–	Number of Forward Close service requests received
6	Get	Close Format Requests	UINT	–	Number of Forward Close service requests which were rejected due to invalid format
7	Get	Close Other Requests	UINT	–	Number of Forward Close service requests which were rejected for reasons other than invalid format
8	Get	Connection Timeouts	UINT	–	Total number of connection timeouts that have occurred in connections controlled by this Connection Manager

TCP/IP Interface Object (Class ID = F5 hex)

This object provides the mechanism to configure a TCP/IP network interface device.

The following table describes the class attributes of the TCP/IP Interface Object (Instance 0):

Attribute ID	Access	Name	Data Type	Value (hex)	Details
1	Get	Revision	UINT	02	Implementation revision of the TCP/IP Interface Object
2	Get	Max Instances	UINT	01	The largest instance number
3	Get	Number of Instance	UINT	01	The number of object instances
6	Get	Max Class Attribute	UINT	07	The largest class attributes value
7	Get	Max Instance Attribute	UINT	06	The largest instance attributes value

The following table describes the Class Services:

Service Code (hex)	Name	Description
01	Get Attribute All	Returns the value of all class attributes
0E	Get Attribute Single	Returns the value of the specified attribute

Instance Codes

Only instance 1 is supported.

The following table describes the Instance Services:

Service Code (hex)	Name	Description
01	Get Attribute All	Returns the value of all instance attributes
0E	Get Attribute Single	Returns the value of the specified instance attribute

The following table describes the Instance Attributes (Instance 1):

Attribute ID	Access	Name	Data Type	Value	Description
1	Get	Status	DWORD	Bit level	<ul style="list-style-type: none"> 0: The interface configuration attribute has not been configured. 1: The interface configuration contains a valid configuration. All other bits are reserved and set to 0.
2	Get	Configuration Capability	DWORD	Bit level	<ul style="list-style-type: none"> 0: BOOTP Client 2: DHCP Client All other bits are reserved and set to 0.
3	Get	Configuration	DWORD	Bit level	<ul style="list-style-type: none"> 0: The interface configuration is valid. 1: The interface configuration is obtained with BOOTP. 2: The interface configuration is obtained with DHCP. 3: Reserved 4: DNS Enable All other bits are reserved and set to 0.
4	Get	Physical Link	UINT	Path size	Number of 16-bit words in the Path element
			Padded EPATH	Path	Logical segments identifying the physical link object. The path is restricted to one logical class segment and one logical instance segment. The maximum size is 12 bytes.
5	Get	Interface configuration	UDINT	IP Address	Hexadecimal format Example: 55 DD DD DE = 85.221.221.222
			UDINT	Network Mask	Hexadecimal format Example: FF 0 0 0 = 255.0.0.0
			UDINT	Gateway Address	Hexadecimal format Example: 55 DD DD DE = 85.221.221.222
			UDINT	Primary Name	0: no primary name server address has been configured.
			UDINT	Secondary Name	0: no secondary name server address has been configured. Otherwise, the name server address shall be set to a valid Class A, B, or C address.
			STRING	Default Domain Name	ASCII characters. Maximum length is 16 characters. Padded to an even number of characters (padding not included in length). 0: no Domain Name is configured
6	Get	Host Name	UINT	–	Host name length
			STRING	–	ASCII characters. Maximum length is 64 characters. Padded to an even number of characters (padding not included in length). 0: no Host Name is configured

Ethernet Link Object (Class ID = F6 hex)

This object maintains link specific counters and status information for an Ethernet 802.3 communications interface.

The following table describes the class attributes of the Ethernet Link Object (Instance 0):

Attribute ID	Access	Name	Data Type	Value (hex)	Details
1	Get	Revision	UINT	03	Implementation revision of the Ethernet Link Object
2	Get	Max Instances	UINT	01	The largest instance number
3	Get	Number of Instances	UINT	01	The number of object instances
6	Get	Max Class Attribute	UINT	07	The largest class attributes value
7	Get	Max Instance Attribute	UINT	03	The largest instance attribute value

The following table describes the Class Services:

Service Code (hex)	Name	Description
01	Get Attribute All	Returns the value of all class attributes
0E	Get Attribute Single	Returns the value of the specified attribute

Instance Codes

Only instance 1 is supported.

The following table describes the Instance Services:

Service Code (hex)	Name	Description
01	Get Attribute All	Returns the value of all instance attributes
0E	Get Attribute Single	Returns the value of the specified instance attribute

The following table describes the Instance Attributes (Instance 1):

Attribute ID	Access	Name	Data Type	Value	Description
1	Get	Interface Speed	UDINT	–	Speed in Mbps (10 or 100)
2	Get	Interface Flags	DWORD	Bit level	<ul style="list-style-type: none"> • 0: link status • 1: half/full duplex • 2...4: negotiation status • 5: manual setting / requires reset • 6: local hardware error detected All other bits are reserved and set to 0.
3	Get	Physical Address	ARRAY of 6 USINT	–	This array contains the MAC address of the product. Format: XX-XX-XX-XX-XX-XX

Serial Line Configuration

Configuring Serial Lines

Introduction

The M221 Logic Controller references are equipped with at least 1 serial line. The controller references without the Ethernet feature support 2 serial lines:

- SL1 (serial line)
- SL2 (serial line)

Each serial line can be configured for one of the following protocols:

- Modbus (RTU or ASCII), page 125. Serial lines are configured for the Modbus RTU protocol by default.
- ASCII, page 125
- Modbus Serial IOScanner, page 128. Only one instance can be configured: if configured on one serial line, it cannot be used on the other serial line.

NOTE: Care must be taken when both the Modbus Serial IOScanner and Message (%MSG) function blocks (see EcoStruxure Machine Expert - Basic, Generic Functions Library Guide) are used in your application, as this can lead to the cancellation of on-going IOScanner communication.

The application must be configured with a functional level (see EcoStruxure Machine Expert - Basic, Operating Guide) of at least **Level 5.0** to support the Modbus Serial IOScanner.

NOTE: The TMH2GDB Remote Graphic Display, page 127 protocol can only be configured on SL1.

Modem Support

A modem connection allows you to:

- Remotely access the controller for the purpose of programming and/or monitoring. In this case, a local modem must be connected to the PC running the EcoStruxure Machine Expert - Basic software, and a modem connection must be configured (see SoMachine Basic, Operating Guide).
- Perform data exchanges between controllers using the Modbus protocol.
- Send or receive messages with any device using the *Send Receive Message* function block.
- Send or receive SMS to or from mobile phone or other devices able to send or receive SMS messages.

Serial lines support the following features to simplify modem connections:

- An initialization (Init) command to send an initial configuration to the modem. This command is automatically sent by the controller after an application download or at power on.
- System bit %S105 to be able to send the Init command to the modem again.
- System word %SW167 to provide the status of the Init command operation.

Serial Line Configuration

This table describes how to configure the serial line:

Step	Action
1	<p>Click the SL1 (Serial line) or SL2 (Serial line) node in the hardware tree to display the serial line configuration.</p> <div data-bbox="368 349 935 954" style="border: 1px solid #ccc; padding: 10px;"> <p>Serial line configuration</p> <p>Protocol settings</p> <p>Protocol: Modbus</p> <hr/> <p>Serial line settings</p> <p>Baud rate: 19200</p> <p>Parity: Even</p> <p>Data bits: 8</p> <p>Stop bits: 1</p> <p>Physical medium</p> <p><input checked="" type="radio"/> RS-485 Polarization: 4.7 kΩ</p> <p><input type="radio"/> RS-232</p> <p style="text-align: right;"> Apply Cancel </p> </div>

This table describes protocol and serial line settings of the serial line:

Parameter	Editable	Value	Default Value	Description
Protocol Settings				
Protocol	Yes	Modbus ASCII TMH2GDB Modbus Serial IOScanner	Modbus	Select a protocol from the drop-down list. NOTE: When using an SR2MOD03 modem and the <i>Send Receive SMS</i> function block, select the ASCII protocol.
Serial Line Settings				
Baud rate	Yes	1200 2400 4800 9600 19200 38400 57600 115200	19200	Allows you to select the data transmission rate (bits per second) from the drop-down list.
Parity	Yes	None Even Odd	Even	Allows you to select the parity of the transmitted data for error detection. Parity is a method of error detection in transmission. When parity is used with a serial port, an extra data bit is sent with each data character, arranged so that the number of bits set to 1 in each character, including the parity bit, is always odd or always even. If a byte is received with an incorrect number of bits set to 1, the byte is invalid.
Data bits	Yes (only for the ASCII protocol)	7 8	8	Allows you to select the data bit from the drop-down list. The number of data bits in each character can be 7 (for true ASCII) or 8.
Stop bits	Yes	1 2	1	Allows you to select the stop bit from the drop-down list. Stop bit is a bit indicating the end of a byte of data. For electronic devices usually 1 stop bit is used. For slow devices like electromechanical teleprinters, 2 stop bits are used.
Physical medium	Yes	RS-485 RS-232	RS-485	Allows you to select the physical medium for communication. You can select either RS-485 or RS-232 medium. For the embedded serial line 2, only RS-485 medium is available. A physical medium in data communications is the transmission path over which a signal propagates. It is an interface for interconnection of devices with the logic controller. NOTE: When using an SR2MOD03 , select the RS-232 option.
Polarization (for the controller)	No	No 4.7 kΩ	No (for RS232) 4.7 kΩ (for RS485)	This parameter is disabled for the controller ⁽¹⁾ .
Polarization (for cartridges)	Yes	Yes No	No	Polarization resistors are integrated in cartridge modules. This parameter allows you to switch on or off polarization.
(1) TM221 embedded SL1 and embedded SL2 contains fixed internal high impedance bias network resistors (4.7 kΩ). Do not use external line termination resistors (standard 150 Ω) without additional external low impedance line polarization resistors (standard 450 Ω...650 Ω) to secure a proper idle voltage state of minimum 200 mV between the D1 and D0 data lines.				

Configuring Modbus and ASCII Protocols

Device Settings for Modbus and ASCII Protocols

This table describes the parameters when the **Modbus** or **ASCII** protocol is selected:

Parameter	Editable	Value	Default Value	Description
Device Settings				
Device	Yes	None Generic Modem SR2MOD01 SR2MOD03	None	Select a device from the drop-down list. Select SR2MOD03 to use the %SEND_RECV_SMS function block.
Init command	Yes	-	-	<p>The Init command is a set of Hayes commands sent to the modem connected on the serial line. It is an ASCII string limited to 128 characters.</p> <p>The logic controller uses this string to configure and verify the modem.</p> <p>The Init command is sent to the modem:</p> <ul style="list-style-type: none"> At power on If the %S105 system bit is set to 1. <p>%SW167 provides the status of the initialization command sent to the modem.</p> <p>A default Init command is used by EcoStruxure Machine Expert - Basic for SR2MOD03 modem. For more information, refer to the .</p> <p>NOTE: To use the SMS function block, change the default Init command to: <i>AT&F;E0;S0=2;Q0;V1;+WIND=0;+CBST=0,0,1;&W;+CNMI=0,2,0,0,0;+CSAS;+CMGF=0;+CMEE=1</i> (see Recv_SMS Function Block (see EcoStruxure Machine Expert - Basic, Generic Functions Library Guide)).</p>

Configuring the Modem Init Command

The Init command is a set of Hayes commands sent to initialize a modem. The default Init command provided by EcoStruxure Machine Expert - Basic configuration screen is to be used with a modem to match with the default serial line configuration for remote access, exchanges between controllers or sending/receiving messages.

Use a PC terminal software if you need to adapt the Init command.

SR2MOD01 Hayes Command

The default Init command provided by EcoStruxure Machine Expert - Basic is:
ate0\n0\v1&d0&k0s0=1s89=0\$EB0#p0\$sb19200n0s28=1s37=13&w0

SR2MOD03 Hayes Command

The default Init command provided by EcoStruxure Machine Expert - Basic is:
AT&F;E0;S0=2;Q0;V1;+WIND=0;+CBST=0,0,1;&W;+CMGF=1;+CNMI=0,2,0,0,0;+CSAS

To send or receive SMS, the command must be modified to: *AT&F;E0;S0=2;Q0;V1;+WIND=0;+CBST=0,0,1;&W;+CNMI=0,2,0,0,0;+CSAS;+CMGF=0;+CMEE=1*

Protocol Settings for Modbus

This table describes the parameters when the **Modbus** protocol is selected:

Parameter	Editable	Value	Default Value	Description
Transmission mode	Yes	RTU ASCII	RTU	Allows you to select the protocol transmission mode for communication from the drop-down list. Select ASCII to use the %SEND_RECV_SMS function block. Protocol advanced parameters are displayed based on the selected protocol.
Addressing	Yes	Slave Master	Slave	Allows you to select the addressing mode. You can only select either of the Slave or Master addressing. Selecting any of the addressing modes clears the present one. A device configured as a slave can send Modbus requests.
Address [1...247]	Yes	1...247	1	Allows you to specify the address ID of the slave. NOTE: This field is displayed only for the addressing of the slave. For master, this field does not appear on the screen.
Response timeout (x 100 ms)	Yes	0...255	10	Defines the maximum time that the controller waits for a response before terminating the exchange in error. Enter 0 to disable the timeout.
Time between frames (ms)	Yes	1...255	10	The period of time between frames (corresponds to inter-frame delay used in other products). NOTE: The value is subject to adjustment to conform to Modbus standard 3.5 character time delay.

Protocol Settings for ASCII

This table describes the parameters when the **ASCII** protocol is selected:

Parameter	Editable	Value	Default Value	Description
Response timeout (x 100 ms)	Yes	0...255	10	Defines the maximum time that the controller waits for a response before terminating the exchange in error. Enter 0 to disable the timeout. NOTE: When using an SR2MOD03 and the function block SMS, enter 0 to disable the timeout.
Stop condition				
Frame length received	Yes (only if the check box is selected)	1...255	0 (if check box is not selected) 1 (if check box is selected)	Allows you to specify the length of the received frame. NOTE: You can configure only one parameter for stop condition that is either Frame length received or Frame received timeout (ms) .
Frame received timeout (ms)	Yes (only if the check box is selected)	1...255	0 (if check box is not selected) 10 (if check box is selected)	Allows you to specify the timeout duration for the received frame. NOTE: When using an SR2MOD03 and the function block SMS, select the checkbox and enter 200.
Frame structure				
Start character	Yes (only if the check box is selected)	1...255	0 (if check box is not selected) 58 (if check box is selected)	Allows you to specify the start character of the frame. The ASCII character corresponding to the start character value is displayed on right-hand side of the value field.
First end character	Yes	1...255	0 (if check box is not selected) 10 (if check box is selected)	Allows you to specify the first end character of the frame. NOTE: To be able to disable the First end character , configure at least one stop condition parameter. The ASCII character corresponding to the first end character value is displayed on right-hand side of the value field.
Second end character	Yes (only if the check box is selected)	1...255	0 (if check box is not selected) 10 (if check box is selected)	Allows you to specify the second end character of the frame. NOTE: This field is disabled when the disabled First end character is disabled. The ASCII character corresponding to the second end character value is displayed on right-hand side of the value field.
Send frame characters	Yes	TRUE/FALSE	FALSE	Allows you to enable or disable the automatic addition of start, first end, and second end characters (when defined) in the frames sent.

Configuring the TMH2GDB Remote Graphic Display

Protocol Settings for Display

This table describes the parameters when the **Display** protocol is selected:

Parameter	Editable	Value	Default Value	Description
Time between frames (ms)	Yes	1...255	10	The period of time between frames (corresponds to inter-frame delay used in other products). NOTE: The value is subject to adjustment to conform to Modbus standard 3.5 character time delay.

Configuring Modbus Serial IOScanner

Description

Only one instance of IOScanner can be defined: if you configure it on a Ethernet port, you cannot configure it on an serial port. Refer to .

The maximum number of TCP and Serial IOScanner objects is:

- 128, if the **Functional Level < 6.0**.
- 512, if the **Functional Level ≥ 6.0**.

If a communication interruption occurs, the IOScanner stops. For more information on the status, page 175, refer to %SW210 or %SW211.

To reset or suspend the Modbus Serial IOScanner, refer to %S110, %S111, %S113 and %S114 in the System Bits Description, page 168).

Protocol Settings

This table describes the parameters when the **Modbus Serial IOScanner** protocol is selected:

Parameter	Editable	Value	Default Value	Description
Transmission mode	Yes	RTU ASCII	RTU	Select the protocol transmission mode for communication from the drop-down list.
Response timeout (x 100 ms)	Yes	0...255	10	Defines the maximum time that the controller waits for a response before terminating the exchange in error. Enter 0 to disable the timeout.
Time between frames (ms)	Yes	1...255	10	The period of time between frames (corresponds to inter-frame delay used in other products). NOTE: The value is subject to adjustment to conform to Modbus standard 3.5 character time delay.

Adding a Device on the Modbus Serial IOScanner

Introduction

This section describes how to add devices to be scanned by the Modbus Serial IOScanner.

You can add up to 16 Modbus slave devices.

EcoStruxure Machine Expert - Basic is supplied with a number of predefined device types. Predefined device types have predefined initialization requests and preconfigured channels to facilitate integration of the devices in the network.

A generic slave device is also provided, for which initialization requests and channels must be configured.



Adding a Device on the Modbus Serial IOScanner

To add a device on the Modbus Serial IOScanner:

Step	Action
1	Choose either: <ul style="list-style-type: none"> • Drive and select one of the supported device types from the dropdown list. • Others and select the device type from the dropdown list. If you cannot find your device type in either list, select Generic device and configure it.
2	Click Add .
3	Configure the device as described in <i>Device Settings</i> , page 129.
4	Click Apply .

Device Settings

This table describes the parameters when the **Modbus Serial IOScanner** protocol is selected:

Parameter	Editable	Value	Default Value	Description
ID	No	0...15	0	Unique device identifier assigned by EcoStruxure Machine Expert - Basic.
Name	Yes	1...32 characters The device name must be unique.	Device x⁽¹⁾	Specify a unique name for the device.
Address	No	– <i>%DRVn</i> ^{(1) (2)}	– <i>%DRV0</i>	<i>%DRVn</i> is used to configure the device in the application using Drive function blocks (see Modicon M221 Logic Controller, Advanced Functions Library Guide).
Type	No	Type of the device	–	The device type is not editable. To change the device type, you must remove the device from the list (by right-clicking and choosing Delete), then add the correct device type.
Slave address	Yes	1...247	1	Address used to identify the device within the network. Duplicate slave addresses are allowed.
Response timeout (x 100 ms)	Yes	0...255	10	The timeout (in milliseconds) used in data exchanges with the device. This value can be adapted individually to the device and overrides the Response timeout set for the master in the Protocol Settings .
Reset variable	Yes	%Mn	–	Specify the address of the memory bit to use to reset the device (re-send the initialization requests). When the specified memory bit is set to 1 by the application, the device is reset.
Init. requests	Yes		-	Click to display the Initialization request assistant window, page 130.
Channels	Yes		-	Click to display the Channel assistant window, page 132.

⁽¹⁾ x and n are integers incremented each time a device or a drive device is added.

⁽²⁾ Only if **Drive** is selected as the device type.

Configuring Initialization Requests

Initialization requests are device-specific commands sent by the Modbus TCP IOScanner or Modbus Serial IOScanner to initialize a slave device. The Modbus TCP IOScanner or Modbus Serial IOScanner does not start cyclic data exchange with the device until all its initialization requests have been acknowledged by the device. During the initialization phase, network objects are not updated.

Up to 20 initialization requests can be defined for each slave device.

The **Initialization request assistant** window presents the defined initialization requests:

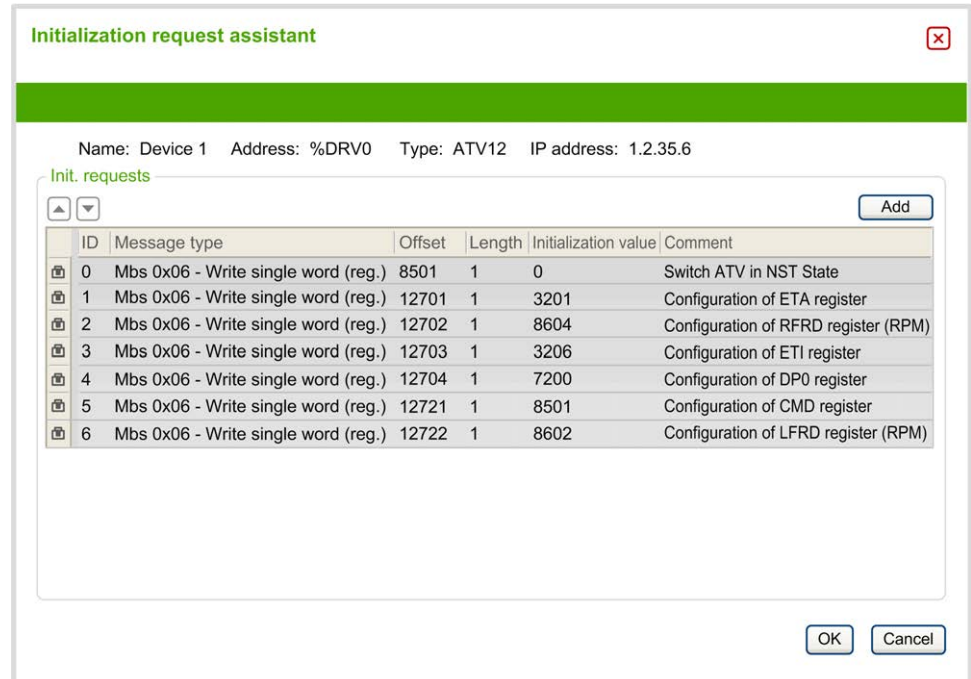

Preconfigured initialization requests are displayed with a lock symbol  and a gray background. Some parameters cannot be modified for predefined initialization requests.

According to the device type that you selected, some initialization requests may be configured.

This table describes the properties of initialization requests:

Parameter	Editable	Value	Default Value	Description
ID	No	0...19	0	Unique initialization request identifier.
Message type	Yes, if initialization request is not predefined.	See Supported Modbus Function Codes, page 136	Mbs 0x05 - Write single bit (coil)	Select the Modbus function code for the type of exchange to use for this initialization request. NOTE: If configuring a generic device that does not support the default Mbs 0x05 - Write single bit (coil) request type, you must replace the default value with a supported request type.
Offset	Yes, if initialization request is not predefined.	0...65535	0	Offset of the first register to initialize.
Length	Yes, if initialization request is not predefined.	1 for Mbs 0x05 - Write single bit (coil) 1 for Mbs 0x06 - Write single word (register) 128 for Mbs 0x0F - Write multiple bits (coils) 123 for Mbs 0x10 - Write multiple words (reg.)	1	Number of objects (memory words or bits) to be initialized. For example, if writing multiple words with Offset = 2 and Length = 3 , %MW2 , %MW3 , and %MW4 are initialized.
Initialization value	Yes, if initialization request is not predefined.	0...65535 if memory words (registers) are being initialized 0...1 if memory bits (coils) are being initialized	0	Value to initialize the targeted registers with.
Comment	Yes, if initialization request is not predefined.	-	Empty	Optionally, type a comment to associate with this request.

Click **Add** to create new initialization requests.

Select an entry then use the up arrow and down arrow buttons to change the order in which the initialization requests are sent to the device.

When the initialization requests have been defined, click **OK** to save the configuration and close the **Initialization request assistant**.

Channel Assistant

Up to 10 channels can be defined for each slave device. Each channel represents a single Modbus request.

NOTE: The number of objects defined (items of data read and written) is validated when you click **Apply** on the properties window.

The **Channel assistant** window lists the defined channels:

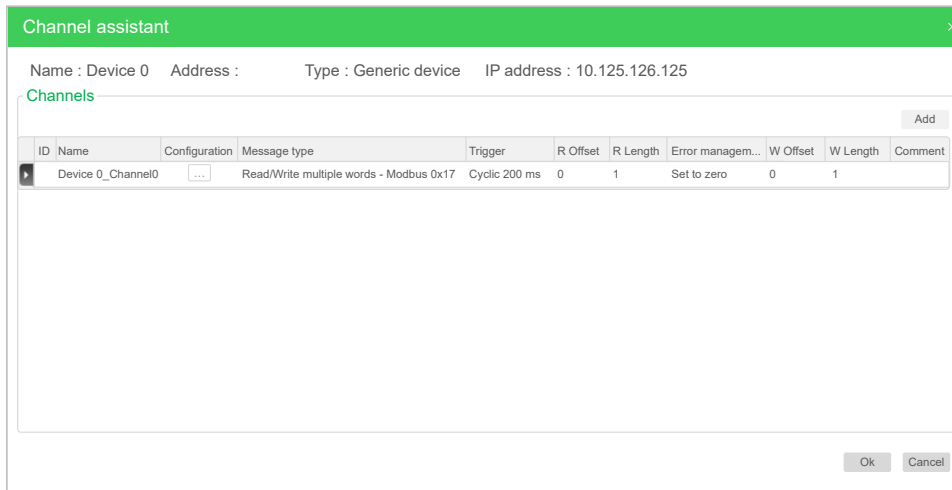

Click on **Configuration** (1) to display the **Channel assistant** window detail (2):

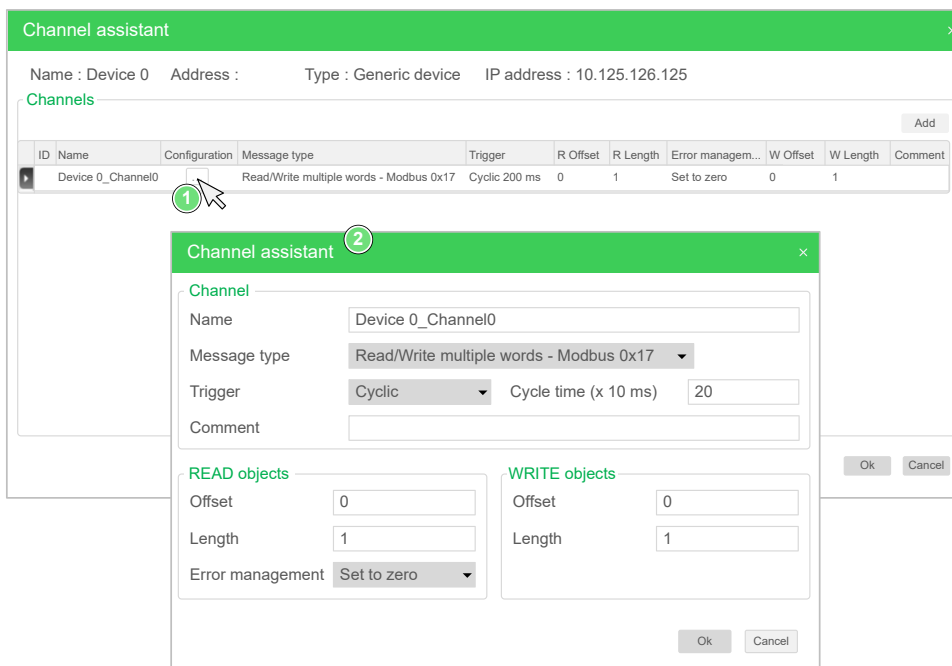

Preconfigured channels are displayed with a lock symbol and a gray background. Some parameters cannot be modified for predefined channels.

This table describes the properties of channels:

Parameter	Editable	Value	Default Value	Description
ID	No	0...19	0	Unique initialization identifier.
Name	Yes	0...32 characters	Device_channel0	Double-click to edit the name of the channel.
Configuration	Yes		-	Click to display the Channel assistant detail window.
Message type	No	-	-	The Modbus function code that was selected in the Channel assistant detail window.
Trigger	No	-	-	The trigger type and cycle time that was selected in the Channel assistant detail window.
R Offset	No	-	-	The READ object offset that was selected in the Channel assistant detail window.
R Length	No	-	-	The READ object length that was selected in the Channel assistant detail window.
Error management	No	-	-	The error management policy that was selected in the Channel assistant detail window.
W Offset	No	-	-	The WRITE object offset that was selected in the Channel assistant detail window.
W Length	No	-	-	The WRITE object length that was selected in the Channel assistant detail window.
Comment	Yes	-	Empty	Optionally, type a comment to associate with this channel.

Click **Add** to create a new channel.

When the channels have been defined, click **OK** to save the configuration and close the **Channel assistant**.

Configuring Channels

Use the **Channel assistant** detail window to configure channels.

The following example shows a channel configured for a Read/Write Multiple Words request (Modbus function code 23). It reads one word from the register with offset 16#0C21 and writes two words to the register with offset 16#0C20. This request is executed when there is a rising edge of the defined **Trigger** (see graphic below):

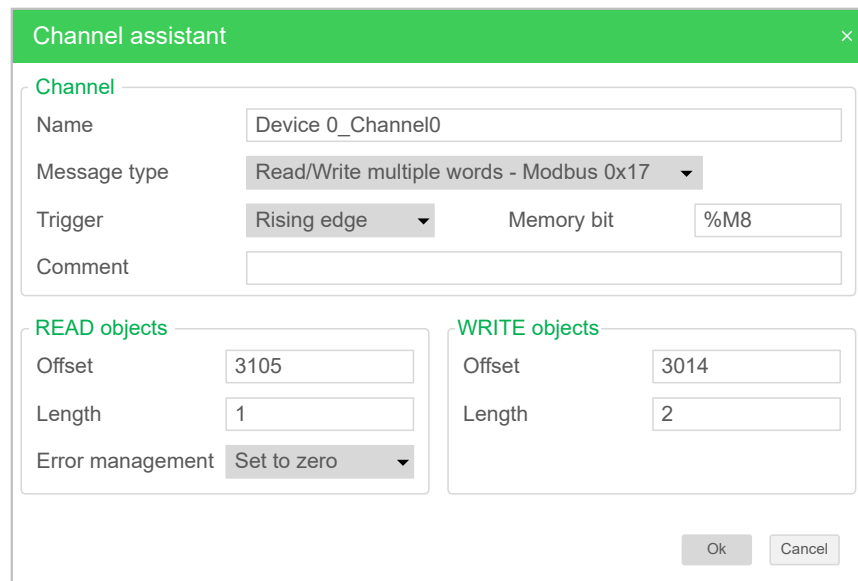

The screenshot shows the 'Channel assistant' configuration window. The 'Channel' section includes: Name: Device_0_Channel0; Message type: Read/Write multiple words - Modbus 0x17; Trigger: Rising edge; Memory bit: %M8; Comment: (empty). The 'READ objects' section includes: Offset: 3105; Length: 1; Error management: Set to zero. The 'WRITE objects' section includes: Offset: 3014; Length: 2. 'Ok' and 'Cancel' buttons are at the bottom right.

This table describes the properties of channels:

Parameter	Editable	Value	Default Value	Description
Name	Yes	0...32 characters	Device 0_Channel0	Enter a name for the channel.
Message type	Yes	See Supported Modbus Function Codes, page 136	Mbs 0x17 - Read/Write mult. words (reg.)	Select the Modbus function code for the type of exchange to use on this channel.
Trigger	Yes	Cyclic Rising edge	Cyclic	Choose the trigger type for the data exchange: <ul style="list-style-type: none"> • Cyclic: The request is triggered with the frequency defined in the Cycle Time (x 10 ms) field • Rising edge: The request is triggered upon detection of a rising edge of a memory bit. Specify the address of the Memory bit to use.
Cycle time (x 10 ms) (If Cyclic is selected)	Yes	1...6000	20	Specify the periodic trigger cycle time, in units of 10 ms.
Memory bit (If Rising edge is selected)	Yes	%Mn	-	Specify a memory bit address, for example, %M8. The data exchange is triggered when a rising edge of this memory bit is detected.
Comment	Yes	-	Empty	Optionally, type a comment to describe the purpose of the channel.
READ objects				
Offset	Yes	0...65535	0	Address of the first memory word (register) or bit (coil) to read.
Length	Yes	See Supported Modbus Function Codes, page 136 for maximum length	-	Number of memory words (registers) or bits (coils) to read.
Error management	Yes	Set to zero Retain last value	Set to zero	Specify how to manage the situation when data can no longer be read from the device: <ul style="list-style-type: none"> • Select Set to zero to set the last data values received to zero. • Select Retain last value to keep the last data values received.
WRITE objects				
Offset	Yes	0...65535	0	Address of the first memory word (register) or bit (coil) to write.
Length	Yes	See Supported Modbus Function Codes, page 136 for maximum length	-	Number of memory words (registers) or bits (coils) to write.

Click **OK** to complete channel configuration.

Supported Modbus Function Codes

Supported Modbus Function Codes

Presentation

This section lists the supported Modbus function codes and their effect on controller memory variables for:

- Modbus Serial, page 135
- Modbus Serial IOScanner, page 136
- Modbus TCP, page 136
- Modbus TCP IOScanner, page 136

Modbus Serial

The following Modbus requests are supported:

Supported Modbus Function Code Dec (Hex)	Supported Sub-Function Code	Description
1 (1 hex) or 2 (2 hex)	–	Read multiple internal bits %M
3 (3 hex) or 4 (4 hex)	–	Read multiple internal registers %MW
5 (5 hex)	–	Write single internal bit %M
6 (6 hex)	–	Write single internal register %MW
8 (8 hex)	0 (0 hex), 10 (0A hex)...18 (12 hex)	Diagnostics
15 (0F hex)	–	Write multiple internal bits %M
16 (10 hex)	–	Write multiple internal registers %MW
23 (17 hex)	–	Read/write multiple internal registers %MW
43 (2B hex)	14 (0E hex)	Read device identification (regular service)

NOTE: The impact of Modbus function codes used by a master M221 Logic Controller depends on the slave device type. In the major types of slave device:

- Internal bit means %M
- Input bit means %I
- Internal register means %MW
- Input register means %IW

Depending on the type of slave and the slave address, an internal bit should be a %M or %Q; an input bit should be a %I or %S, an input register should be a %IW or a %SW and an internal register should be a %MW or a %QW.

For more details, refer to the documentation of the slave device.

Modbus Serial IScanner and Modbus TCP IScanner

This table lists the Modbus function codes supported by the Modbus Serial IScanner and Modbus TCP IScanner:

Function Code Dec (Hex)	Description	Available For Configuration	Maximum Length (Bits)
1 (1 hex)	Read multiple bits (coils)	Channel	128
2 (2 hex)	Read multiple bits (discrete inputs)	Channel	128
3 (3 hex)	Read multiple words (holding registers)	Channel	125
4 (4 hex)	Read multiple words (input registers)	Channel	125
5 (5 hex)	Write single bit (coil)	Channel Initialization Value (default message type for initialization values)	1
6 (6 hex)	Write single word (register)	Channel Initialization Value	1
15 (0F hex)	Write multiple bits (coils)	Channel Initialization Value	128
16 (10 hex)	Write multiple words (registers)	Channel Initialization Value	123
23 (17 hex)	Read/write multiple words (registers)	Channel (default message type for channel configuration)	125 (read) 121 (write)

Modbus Mapping Table for Modbus TCP

Modbus TCP slave devices support a subset of the Modbus function codes. Function codes originating from a Modbus master with matching unit ID are directed to the Modbus mapping table and access network objects (%/WM and %QWM) of the controller. Refer to Modbus TCP Slave Device I/O Mapping Table, page 102.

State Machine Diagram for Modbus IOscanner

State Machine Diagram for Modbus IOscanner

Description

The following graphic shows the states of the Modbus IOScanner:

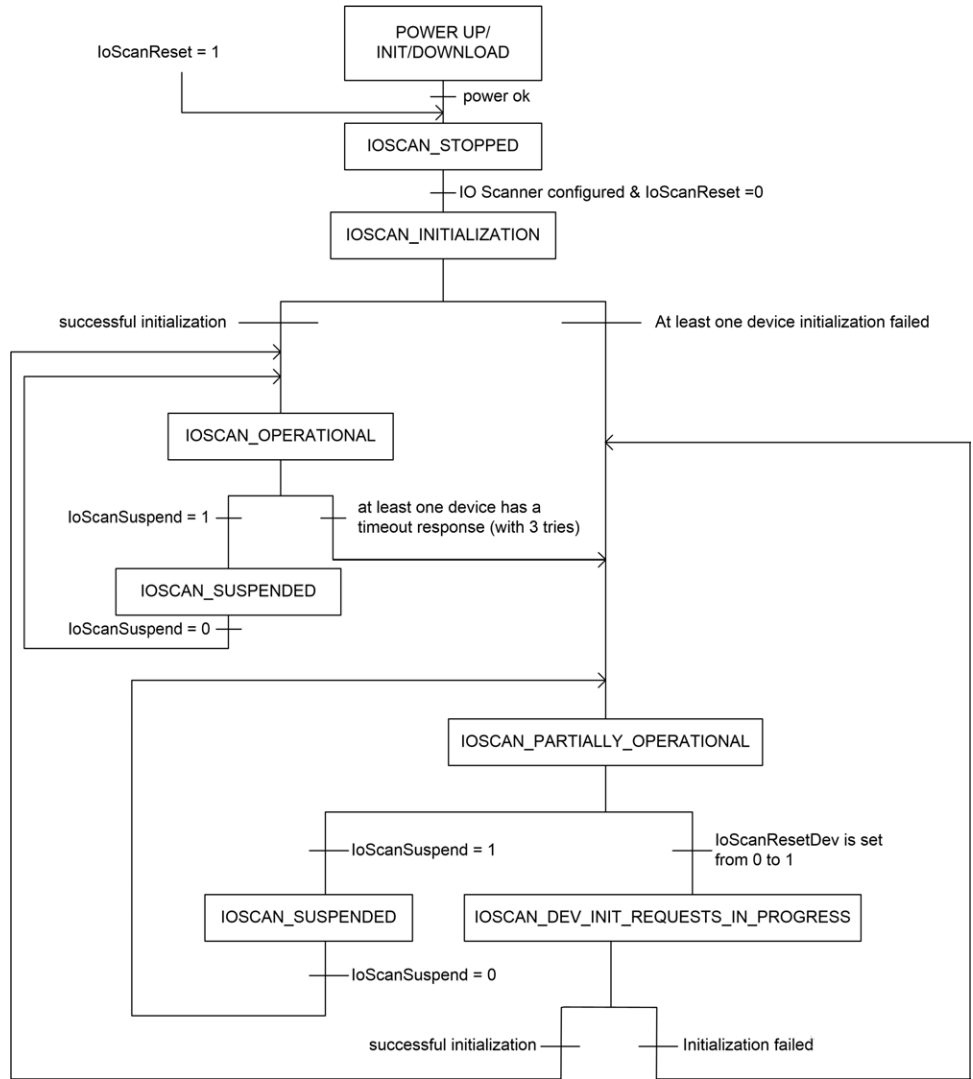

The following table displays the system objects for each IOScanner position:

Object Description	SL1	SL2	Ethernet
State of the IOScanner	%SW210	%SW211	%SW212
loScanReset	%S110	%S111	%S112
loScanSuspend	%S113	%S114	%S115
loScanResetDev	%Mx defined in the device configuration		

SD Card

What's in This Chapter

File Management Operations	138
SD Card Supported File Types	139
Clone Management	140
Firmware Management.....	141
Application Management	145
Post Configuration Management	146
Error Log Management	148
Memory Management: Backing Up and Restoring Controller Memory	151

Introduction

The Modicon M221 Logic Controller allows file transfers with an SD card.

This chapter describes how to manage Modicon M221 Logic Controller files with an SD card.

You can use the SD card when you want to store data. Refer to Data Logging.

File Management Operations

Introduction

The Modicon M221 Logic Controller allows the following types of file management with an SD card:

- Clone management, page 140: back up the application, firmware, and post configuration (if it exists) of the logic controller
- Firmware management, page 141: download firmware directly to the logic controller, and load firmware to the Remote Graphic Display
- Application management, page 145: back up and restore the logic controller application, or copy it to another logic controller of the same reference
- Post configuration management, page 146: add, change, or delete the post configuration file of the logic controller
- Error log management, page 148: back up or delete the error log file of the logic controller
- Memory management, page 151: Back up and restore memory objects of the controller

NOTE:

- Logic controller logic solving and services execution continues during file transfers.
- Certain commands require a power cycle of the logic controller. See the description of the commands for more information.
- The Modicon M221 Logic Controller accepts only SD cards formatted in FAT or FAT32.

With the use of the SD card, powerful operations can be automatically conducted affecting the behavior of your logic controller and resident application. Care must be taken when inserting an SD card into the controller; you must be aware of the affect that the contents of the SD card will have on your logic controller.

NOTE: File management with SD card uses script files. These scripts can be automatically created with the **Memory Management** task (see EcoStruxure Machine Expert - Basic, Operating Guide).

▲ WARNING**UNINTENDED EQUIPMENT OPERATION**

- You must have operational knowledge of your machine or process before connecting an SD card to your logic controller.
- Ensure that guards are in place so that any potential affect of the contents of the SD card will not cause injury to personnel or damage to equipment.

Failure to follow these instructions can result in death, serious injury, or equipment damage.

If you remove power to the device, or there is a power outage or communication interruption during the transfer of the application, your device may become inoperative. If a communication interruption or a power outage occurs, reattempt the transfer. If there is a power outage or communication interruption during a firmware update, or if an invalid firmware is used, your device will become inoperative. In this case, use a valid firmware and reattempt the firmware update.

NOTICE**INOPERABLE EQUIPMENT**

- Do not interrupt the transfer of the application program or a firmware change once the transfer has begun.
- Re-initiate the transfer if the transfer is interrupted for any reason.
- Do not attempt to place the device into service until the file transfer has completed successfully.

Failure to follow these instructions can result in equipment damage.

SD Card Supported File Types

Introduction

This table lists the file locations and types of file that can be managed:

SD card folder	Description	Default file name
/	Script file	Script.cmd
/	Script log	Script.log
/disp/	Remote Graphic Display firmware file	TMH2GDB.mfw
/sys/os	Logic controller firmware file	M221.mfw
/TM3	TM3 analog expansion modules firmware	TM3_Ana.mfw
/usr/app	Application file	*.smbk
/usr/cfg	Post configuration file	Machine.cfg
/usr/mem	Memory back up file	Memories.csv
/sys/log	Detected error log file	PlcLog.csv

Script File Commands

A script file is a text file stored in the root directory of the SD card containing commands to manage exchanges with the controller. Script files must be encoded in ANSI format.

This table describes the supported script commands:

Command	Description
Download	Download a file from the SD card to the controller.
Upload	Upload files contained in controller memory to the SD card.
Delete	Delete files contained in a controller.

Script File Examples

Download commands:

```
Download "/usr/cfg"
Download "/sys/os/M221.mfw"
Download "/disp/TMH2GDB.mfw"
```

Upload commands:

```
Upload "/usr/app/*"
Upload "/usr/cfg/Machine.cfg"
```

Delete commands:

```
Delete "/usr/app/*"
Delete "/sys/log/PlcLog.csv"
```

NOTE: Post configuration files specified in **Upload** or **Delete** commands must have the extension `.cfg` or `.CFG`.

If no post configuration file is specified, or the specified file name does not exist, the default file name `Machine.cfg` is assumed.

Script Log

A `script.log` file is automatically created in the SD card root directory after script operations. The status of the script operations can be verified reading this file.

Clone Management

Cloning

Cloning allows you to automatically back up the application, firmware, and post configuration (if it exists) of the Modicon M221 Logic Controller to the SD card.

The SD card can then be used to later restore the firmware, application, and post configuration (if it exists) to the logic controller, or copy them to another logic controller with the same reference.

Before cloning a controller, the M221 Logic Controller verifies whether the application is copy-protected or not. For details, refer to Password Protecting an Application (see EcoStruxure Machine Expert - Basic, Operating Guide).

NOTE:

- The SD card must be empty and correctly formatted to perform this procedure.
- The SD card name must be different from `DATA`, refer to Data Logging.
- The detected error log and data memory are not cloned.
- If the application is password-protected, the clone operation is blocked (the **SD** LED is flashing).

Creating a Clone SD Card

This procedure describes how to copy the application, firmware, and post configuration (if it exists) from the controller to an SD card:

Step	Action
1	Format an SD card on the PC.
2	Insert the SD card into the controller. Result: The clone operation starts automatically and the SD LED is illuminated.
3	Wait until the end of the operation (until the SD LED is off or flashing). If an error is detected, the SD LED flashes and the detected error is logged in <code>Script.log</code> file. NOTE: The clone operation lasts 2 or 3 minutes. The clone operation has a low priority in order to minimize impact on the user logic and communication performance of the logic controller. Depending on the amount of free time in your program, the operation may require more time to complete if the logic controller is in <i>RUNNING</i> state compared to the <i>STOPPED</i> state.
4	Remove the SD card from the controller.

Restoring or Copying from a Clone SD Card

This procedure describes how to download the application, firmware, and post configuration (if it exists) stored in the SD card to your controller:

Step	Action
1	Remove power from the controller.
2	Insert the SD card into the controller.
3	Restore power to the controller. Result: The clone operation is in progress. NOTE: The SD LED is turned on during the operation.
4	Wait until the end of the operation (until the SD LED is off or flashing). If an error is detected, the SD and ERR LEDs flash and the detected error is logged in <code>Script.log</code> file.
5	Remove the SD card to restart the controller.

NOTE: Downloading a cloned application to the controller first removes the existing application from controller memory, regardless of any user access-rights that may be enabled in the target controller.

Firmware Management

Overview

You can use an SD card to download firmware updates directly to the logic controller, a Remote Graphic Display, or TM3 analog expansion modules.

Refer to [Controller States and Behavior](#), page 37 for information on the logic controller operating states and status of the LEDs.

To perform firmware management, the SD card name must be different from `DATA`, refer to [Data Logging](#).

Downloading Firmware to the Controller

This table describes how to download a firmware to the logic controller using an SD card:

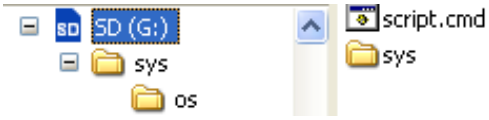
Step	Action
1	Remove power from the controller.
2	Insert an empty SD card into the PC that is running EcoStruxure Machine Expert - Basic.
3	Create a file called <i>script.cmd</i> in the SD card root directory.
4	Edit the file and insert the following command: Download <code>"/sys/os"</code>
5	<p>Create the folder path <code>\sys\os</code> in the SD card root directory and copy the firmware file in the <code>os</code> folder:</p>  <p>NOTE: A firmware file example and the script are available in the folder <i>Firmwares & PostConfiguration\M221</i> of the EcoStruxure Machine Expert - Basic installation folder.</p> <p>The firmware file name for the M221 Logic Controller is <code>M221.mfw</code>.</p>
6	Remove the SD card from the PC and insert it into the SD card slot of the logic controller.
7	<p>Restore power to the controller.</p> <p>Result: Copying of the firmware file begins. During the operation, the SD system LED on the logic controller is illuminated.</p> <p>NOTE: Avoid removing power from the logic controller while the operation is in progress.</p>
8	<p>Wait until the end of the operation (until the SD LED is off or flashing).</p> <p>If an error is detected, the SD and ERR LEDs flash and the detected error is logged in <code>Script.log</code> file.</p>
9	Remove the SD card.
10	Reconnect the USB programming cable to the logic controller and login to the logic controller with the EcoStruxure Machine Expert - Basic software.

Downloading Firmware to the Remote Graphic Display

NOTE: Before downloading, verify whether the firmware version to be installed is compatible with the installed EcoStruxure Machine Expert - Basic software version and the logic controller firmware version. Refer to Compatibility of the Remote Graphic Display (see Modicon TMH2GDB, Remote Graphic Display, User Guide)

This table describes how to download a firmware to the Remote Graphic Display using an SD card:

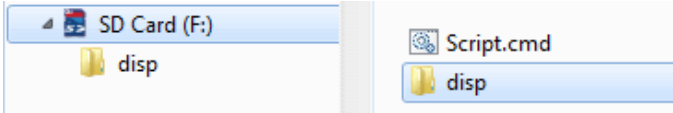
Step	Action
1	Apply power to the logic controller.
2	Connect the Remote Graphic Display to the logic controller (see Modicon TMH2GDB, Remote Graphic Display, User Guide).
3	Insert an empty SD card into the PC that is running EcoStruxure Machine Expert - Basic.
4	Create a file called <i>script.cmd</i> in the SD card root directory.
5	Edit the file and insert the following command: <code>Download "/disp/TMH2GDB.mfw"</code>
6	Create the folder path <i>/disp/</i> in the SD card root directory and copy the firmware file in the <i>disp</i> folder:  <p>NOTE: The firmware file and an example script are available in the folder <i>Firmwares & PostConfiguration\TMH2GDB\</i> of the EcoStruxure Machine Expert - Basic installation folder.</p> <p>The firmware file name for the Remote Graphic Display is <i>TMH2GDB.mfw</i>.</p>
7	Remove the SD card from the PC and insert it into the SD card slot of the M221 Logic Controller. Result: The logic controller begins transferring the firmware file from the SD card to the Remote Graphic Display. During this operation: <ul style="list-style-type: none"> the message File Transfer is displayed on the Remote Graphic Display the SD system LED on the M221 Logic Controller is illuminated system word <i>%SW182</i> is set to 5 (Display firmware transfer in progress) NOTE: Do not disconnect the Remote Graphic Display or remove power from the M221 Logic Controller while the operation is in progress. The firmware update takes 5 to 6 minutes.
8	Wait until the end of the operation (until the SD LED is off or flashing). If an error is detected, the SD and ERR LEDs flash and the detected error is logged in <i>Script.log</i> file. NOTE: Restoring the file system on the Remote Graphic Display (red backlight) is part of the process.

Downloading Firmware to TM3 Expansion Modules

The firmware can be updated in:

- TM3D• and TM3XTYS4 with firmware version ≥ 28 (SV ≥ 2.0)
- TM3A• and TM3T• with firmware version ≥ 26 (SV ≥ 1.4)

NOTE: The software version (SV) is found on the packaging and product labels.

Firmware updates are performed using a script file on an SD card. When the SD card is inserted in the SD card slot of the M221 Logic Controller, the logic controller updates the firmware of the TM3 analog expansion modules on the I/O bus, including those that are:

- Connected remotely, using a TM3 Transmitter/Receiver module
- In configurations comprising a mix of TM3 and TM2 expansion modules.

This table describes how to download a firmware to one or more TM3 expansion modules using an SD card:

Step	Action
1	Apply power to the controller.
2	Ensure that the controller is in the <i>EMPTY</i> state by deleting the application in the controller. You can do this with EcoStruxure Machine Expert by using one of the following script commands: Delete "usr/*" Delete "usr/app"
3	Insert an empty SD card into the PC.
4	Create a file called <i>script.cmd</i> in the SD card root directory.
5	Edit the file and insert the following command: Download "/TM3/<filename>/*" NOTE: <filename> is the file name of the firmware you wish to update. The asterisk signifies that all modules will be updated. To download the firmware to one specific TM3 expansion module, replace the asterisk with the position of the expansion module in the configuration. For example, to specify the module at position 4: Download "/TM3/<filename>/4"
6	Create the folder path <i>/TM3/</i> in the SD card root directory and copy the firmware file to the <i>TM3</i> folder. NOTE: A firmware file (the firmware file valid at the time of the installation of EcoStruxure Machine Expert) and an example script are available in the folder <i>Firmwares & PostConfiguration\TM3\</i> of the EcoStruxure Machine Expert installation folder.
7	Remove the SD card from the PC and insert it into the SD card slot of the controller. Result: The controller begins transferring the firmware file from the SD card to the updatable TM3 expansion modules or to the one module specified in step 5. During this operation, the SD system LED on the controller is illuminated. NOTE: The firmware update takes 10 to 15 seconds for each expansion module being updated. Do not remove power from the controller, or remove the SD card, while the operation is in progress. Otherwise, the firmware update may be unsuccessful and the modules may no longer function correctly. In this case, run the Recovery Procedure (see Modicon TM3 (EcoStruxure Machine Expert - Basic), Expansion Modules Configuration, Programming Guide) to reinitialize the firmware on the modules.
8	Wait until the end of the operation (until the SD LED is off or flashing). If an error is detected, the SD and ERR LEDs flash and the detected error is logged in <i>Script.log</i> file.
9	After the update(s), remove power from the controller (and TM3XREC1 receiver module, if any).
10	Restore power to the controller (and TM3XREC1 receiver module, if any). Result: The module(s) is (are) updated.

If you remove power to the device, or there is a power outage or communication interruption during the transfer of the application, your device may become inoperative. If a communication interruption or a power outage occurs, reattempt the transfer. If there is a power outage or communication interruption during a firmware update, or if an invalid firmware is used, your device will become inoperative. In this case, use a valid firmware and reattempt the firmware update.

NOTICE

INOPERABLE EQUIPMENT

- Do not interrupt the transfer of the application program or a firmware change once the transfer has begun.
- Re-initiate the transfer if the transfer is interrupted for any reason.
- Do not attempt to place the device into service until the file transfer has completed successfully.

Failure to follow these instructions can result in equipment damage.

Application Management

Overview

You can use an SD card to back up and restore your controller application, or copy it to another controller with the same reference.

To perform application management, the SD card name must be different from `DATA`, refer to Data Logging.

Backing Up an Application

This table describes how to back up the controller application on the SD card:

Step	Action
1	Create a <code>script.cmd</code> file with a text editor on your PC.
2	Edit the file and insert the following line: <code>Upload "/usr/app"</code>
3	Copy the script file to the root folder of the SD card.
4	Insert the prepared SD card in the controller. Result: Copying of the application file begins. During the operation, the SD system LED on the logic controller is illuminated. NOTE: Avoid removing power from the logic controller while the operation is in progress. NOTE: The application backup process has a low priority in order to minimize impact on the program and communication performance of the logic controller. Depending on the amount of free time in your program, the operation may take considerably longer to complete if the logic controller is in <i>RUNNING</i> state compared to the <i>STOPPED</i> state.
5	Wait until the end of the operation (until the SD LED is off or flashing). If an error is detected, the SD and ERR LEDs flash and the detected error is logged in <code>Script.log</code> file. Result: The application file (* .smbk) is saved on the SD card.

Restoring an Application or Copying an Application to Another Controller

This table describes how to transfer the controller application from the SD card to the controller:

Step	Action
1	Take an SD card previously created and edit the <i>script.cmd</i> file in the root folder of the SD card with a text editor.
2	Replace the content of the script by the following line: Download "/usr/app"
3	Remove power from the controller.
4	Insert the prepared SD card in the controller.
5	Restore power to the controller. Result: Copying of the application file begins. During the operation, the SD system LED on the logic controller is illuminated. NOTE: Avoid removing power from the logic controller while the operation is in progress.
6	Wait until the end of the operation (until the SD LED is off or flashing). If an error is detected, the SD and ERR LEDs flash and the detected error is logged in <i>Script.log</i> file.
7	Remove the SD card to restart the controller.

Post Configuration Management

Overview

You can use an SD card to add, change, or delete the post configuration file of your controller.

To perform post configuration management, the SD card name must be different from *DATA*, refer to Data Logging.

Adding or Changing a Post Configuration

This table describes how to add or change the controller post configuration:

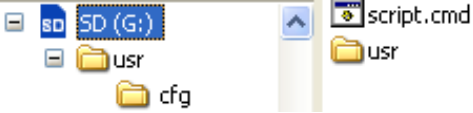
Step	Action
1	Create a file called <code>script.cmd</code> .
2	Edit the file and insert the following line: <code>Download "/usr/cfg"</code>
3	Copy the post configuration file (<code>Machine.cfg</code>) to the folder <code>\usr\cfg</code> and the script file to the root folder of the SD card:  NOTE: A post configuration file example and the associated script are available in the directory <code>Firmwares & PostConfiguration\PostConfiguration\add_change\</code> of the EcoStruxure Machine Expert - Basic installation directory.
4	If necessary, edit the <code>Machine.cfg</code> file to configure your post configuration parameters.
5	Insert the prepared SD card in the controller. Result: Downloading of the post configuration file begins. During the operation, the SD system LED on the logic controller is illuminated. NOTE: Avoid removing power from the logic controller while the operation is in progress. NOTE: Before the download the file format is verified, as well as if all of the channels, parameters, and values configured are valid; in case of detected error the download is aborted. NOTE: If a post configuration parameter is incompatible with the physical configuration, it is ignored.
6	Wait until the end of the operation (until the SD LED is off or flashing). If an error is detected, the SD and ERR LEDs flash and the detected error is logged in <code>Script.log</code> file.
7	Do a power cycle or an initialization command to apply the new post configuration file.

Reading a Post Configuration File

This table describes how to read the post configuration file of the controller:

Step	Action
1	Create a <code>script.cmd</code> file with a text editor on your PC.
2	Edit the file and insert the following line: <code>Upload "/usr/cfg"</code>
3	Copy the script file to the root folder of the SD card.
4	Insert the prepared SD card in the controller. Result: Copying of the post configuration file begins. During the operation, the SD system LED on the logic controller is illuminated. NOTE: Avoid removing power from the logic controller while the operation is in progress. NOTE: The application backup process has a low priority to minimize impact on the program and communication performance of the logic controller. Depending on the amount of free time in your program, the operation may take considerably longer to complete, if the logic controller is in <i>RUNNING</i> state compared to the <i>STOPPED</i> state.
5	Wait until the end of the operation (until the SD LED is off or flashing). If an error is detected, the SD and ERR LEDs flash and the detected error is logged in <code>Script.log</code> file. Result: The post configuration file is saved on the SD card.

Removing a Post Configuration File

This table describes how to remove the post configuration file of the controller:

Step	Action
1	Insert an empty SD card into the PC that is running EcoStruxure Machine Expert - Basic.
2	Create a file called <code>script.cmd</code> .
3	Edit the file and insert the following line: <code>Delete "/usr/cfg"</code>
4	Copy the script file available in the directory <i>Firmwares & PostConfiguration</i> (<i>PostConfiguration\remove</i>) of the EcoStruxure Machine Expert - Basic installation directory to the root directory of the SD card.
5	Insert the prepared SD card in the controller. Result: The post configuration file is removed. During the operation, the SD system LED on the logic controller is illuminated. NOTE: Avoid removing power from the logic controller while the operation is in progress.
6	Wait until the end of the operation (until the SD LED is off or flashing). If an error is detected, the SD and ERR LEDs flash and the detected error is logged in <code>Script.log</code> file.
7	Do a power cycle or an initialization command to apply the application parameters.

Error Log Management

Overview

You can use the SD card to back up or delete the error log file of the logic controller.

To perform error log management, the SD card name must be different from `DATA`, refer to Data Logging.

Backing Up the Error Log

This table describes how to back up the logic controller error log file on the SD card:

Step	Action
1	Create a <code>script.cmd</code> file with a text editor on your PC.
2	Edit the file and insert the following line: <code>Upload "/sys/log"</code>
3	Copy the script file to the root folder of the SD card.
4	Insert the prepared SD card in the logic controller. Result: Transfer of the error log file begins. During the operation, the SD system LED on the logic controller is illuminated. NOTE: Avoid removing power from the logic controller while the operation is in progress.
5	Wait until the end of the operation (until the SD LED is off or flashing). If an error is detected, the SD and ERR LEDs flash and the detected error is logged in <code>Script.log</code> file. Result: The error log file (<code>PlcLog.csv</code>) is saved on the SD card.

Deleting the Error Log

This table describes how to delete the error log file in the logic controller:

Step	Action
1	Create a <i>script.cmd</i> file with a text editor on your PC.
2	Edit the file and insert the following line: Delete "/sys/log"
3	Copy the script file to the root folder of the SD card.
4	Insert the prepared SD card in the logic controller. Result: Deleting of the error log file begins. During the operation, the SD system LED on the logic controller is illuminated. NOTE: Avoid removing power from the logic controller while the operation is in progress.
5	Wait until the end of the operation (until the SD LED is off or flashing). If an error is detected, the SD and ERR LEDs flash and the detected error is logged in <i>Script.log</i> file. Result: The error log file (<i>PlcLog.csv</i>) is deleted from the logic controller.

Error Log Format

The logic controller provides an error list containing the last 10 detected errors in the log memory. Each error entry into the error log file is composed of the following parts:

- Date and time
- Level
- Context
- Error code
- Priority (internal use only)

After an upload through the SD card, the code is represented as in the example below:

```
02/06/14, 12:04:01, 0x0111000100
```

This table describes the meaning of the hexadecimal error representation:

Group	Error code (hex)	Error Description	Result
General	0800011xx	Invalid hardware calibration parameters	Ethernet channel is inoperative %SW118.bit10 set to 0 ERR LED flashes
Operating system	0F01xxxxxx	Operating system error detected	Transition to <i>HALTED</i> state
Memory management	0F030009xx	Internal memory allocation error detected	Transition to <i>HALTED</i> state
SD card	010C001Bxx	Error while accessing an SD card; the operation exceeded an internal timeout (3000 ms).	The SD card operation is canceled.
Watchdog timer	0104000Axx	Logic controller resource utilization greater than 80% - first detection	Watchdog timeout signaled: %S11 set to 1 ERR LED flashes
	0804000Bxx	Logic controller resource utilization greater than 80% - second consecutive detection	Transition to <i>HALTED</i> state
	0804000Cxx	Task watchdog timer in master task	Transition to <i>HALTED</i> state
	0804000Dxx	Task watchdog timer in periodic task	Transition to <i>HALTED</i> state
Battery	0105000Exx	Battery is depleted	Depleted battery signaled: %S75 set to 1 BAT LED illuminated
RTC	01060012xx	RTC is invalid	Invalid RTC signaled: %SW118.bit12 set to zero %S51 set to 1
User application	0807000Fxx	Application is not compatible with firmware	Transition to <i>EMPTY</i> state
	08070010xx	Checksum error detected	Transition to <i>EMPTY</i> state
Ethernet	010B0014xx	Duplicate IP address detected	Duplicate IP signaled: %SW62 set to 1 %SW118.bit9 set to 0 ERR LED flashes
Embedded I/O	010D0013xx	Short-circuit detected on protected output	Over-current signaled: %SW139 set to 1 (depending on the output block) ERR LED flashes
Read non-volatile memory	01110000xx	Read error detected - file not found	Unsuccessful read operation
	01110001xx	Read error detected - incorrect logic controller type	
	01110002xx	Read error detected - incorrect header	
	01110003xx	Read error detected - incorrect area descriptor	
	01110004xx	Read error detected - incorrect area descriptor size	
Write non-volatile memory	01120002xx	Write error detected - incorrect header	Unsuccessful write operation
	01120004xx	Write error detected - incorrect area descriptor size	
	01120005xx	Write error detected - unsuccessful erase	
	01120006xx	Write error detected - incorrect header size	
Persistent variable	01130007xx	Checksum error detected in persistent variables	Persistent variables cannot be restored
	01130008xx	Size error detected in persistent variables	

Group	Error code (hex)	Error Description	Result
Ethernet IP	01140012xx	Unsuccessful Ethernet IP variable creation	Variable cannot be created, unsuccessful operation

Memory Management: Backing Up and Restoring Controller Memory

Overview

You can use an SD card to back up and restore controller memory objects, or copy the memory objects to another controller.

Backing Up Controller Memory

Step	Action
1	Create a <i>script.cmd</i> file with a text editor on your PC.
2	Edit the file and insert the following line: <code>Upload "/usr/mem"</code>
3	Copy the script file to the root folder of the SD card.
4	Insert the prepared SD card in the controller. Result: Copying of the memory begins. During the operation, the SD system LED on the logic controller is illuminated. NOTE: Avoid removing power from the logic controller while the operation is in progress. NOTE: The memory backup process has a low priority to minimize impact on the program and communication performance of the logic controller. Depending on the amount of free time in your program, the operation may take considerably longer to complete if the logic controller is in <i>RUNNING</i> state compared to the <i>STOPPED</i> state.
5	Wait until the end of the operation (until the SD LED is off or flashing). If an error is detected, the SD and ERR LEDs flash and the detected error is logged in <i>Script.log</i> file. Result: The memory file (*.csv) is saved on the SD card.

Restoring Controller Memory or Copying to Another Controller

Step	Action
1	Edit the <i>script.cmd</i> file in the root folder of the SD card with a text editor.
2	Replace the content of the script by the following line: <code>Download "/usr/mem"</code>
3	Insert the prepared SD card in the controller. Result: Copying of the memory file begins. During the operation, the SD system LED on the logic controller is illuminated. NOTE: Avoid removing power from the logic controller while the operation is in progress.
4	Wait until the end of the operation (until the SD LED is off or flashing). If an error is detected, the SD and ERR LEDs flash and the detected error is logged in <i>Script.log</i> file.

Programming the M221 Logic Controller

What's in This Part

I/O Objects	153
Network Objects.....	157
System Objects.....	167

Overview

This part provides information about the system and I/O objects specific to the M221 Logic Controller. These objects are displayed in the **Programming** tab.

For descriptions of all other objects, refer to EcoStruxure Machine Expert - Basic Generic Functions Library Guide.

I/O Objects

What's in This Chapter

Digital Inputs (%I).....	153
Digital Outputs (%Q).....	154
Analog Inputs (%IW).....	154
Analog Outputs (%QW)	156

Digital Inputs (%I)

Introduction

Digital input bit objects are the image of digital inputs on the logic controller.

Displaying Digital Input Properties

Follow these steps to display properties of the digital inputs:

Step	Action
1	Select the Tools tab in the left-hand area of the Programming window.
2	Click I/O objects > Digital inputs . Result: Digital input properties appear on the screen.

Digital Inputs Properties

This table describes each property of the digital input:

Parameter	Editable	Value	Default Value	Description
Used	No	True/False	False	Indicates whether the input channel is being referenced in a program.
Address	No	%I0.i	–	Displays the address of the digital input on the controller, where i represents the channel number. If the controller has n digital input channels, the value of i is given as 0...n-1. For example, %I0.2 is the digital input at the digital input channel number 2 of the logic controller.
Symbol	Yes	–	–	The symbol associated with this address. Double-click in the Symbol column and type the name of the symbol to associate with this input. If a symbol already exists, you can right-click in the Symbol column and choose Search and Replace to find and replace occurrences of this symbol throughout the program and/or program comments.
Comment	Yes	–	–	A comment associated with this address. Double-click in the Comment column and type an optional comment to associate with this channel.

Digital Outputs (%Q)

Introduction

Digital output bit objects are the image of digital outputs on the logic controller.

Displaying Digital Output Properties

Follow these steps to display properties of the digital outputs:

Step	Action
1	Select the Tools tab in the left-hand area of the Programming window.
2	Click I/O objects > Digital outputs . Result: Digital output properties appear on the screen.

Digital Outputs Properties

This table describes each property of the digital output:

Parameter	Editable	Value	Default Value	Description
Used	No	True/False	False	Indicates whether the output channel is being referenced in a program.
Address	No	%Q0.i	–	Displays the address of the digital output on the controller, where i represents the channel number. If the controller has n digital output channels, the value of i is given as 0...n-1. For example, %Q0.3 is the digital output at the digital output channel number 3 of the logic controller.
Symbol	Yes	–	–	The symbol associated with this address. Double-click in the Symbol column and type the name of the symbol to associate with this output. If a symbol already exists, you can right-click in the Symbol column and choose Search and Replace to find and replace occurrences of this symbol throughout the program and/or program comments.
Comment	Yes	–	–	The comment associated with this address. Double-click in the Comment column and type an optional comment to associate with this channel.

Analog Inputs (%IW)

Introduction

Analog input word objects are the digital values of an analog signal connected to the logic controller.

Two 0-10V analog inputs are embedded in the logic controller. The embedded analog inputs use a 10 bits resolution converter so that each increment is approximately 10 mV ($10V/2^{10}-1$). Once the system detects the value 1023, the channel is considered to be saturated.

Refer to M221 Hardware Guide (see Modicon M221 Logic Controller, Hardware Guide) and TMC2 Cartridges Hardware Guide used in the configuration for more details.

Displaying Analog Input Properties

Follow these steps to display properties of the analog inputs:

Step	Action
1	Select the Tools tab in the left-hand area of the Programming window.
2	Click I/O objects > Analog inputs . Result: Analog input properties appear on the screen.

Analog Inputs Properties

This table describes each property of the analog input:

Parameter	Edita-ble	Value	Default Value	Description
Used	No	True/False	False	Indicates whether the input channel is being referenced in a program.
Address	No	%IW0.i	–	Displays the address of the embedded analog input on the controller, where i represents the channel number. If the controller has n analog input channels, the value of i is given as 0...n-1. For example, %IW0.1 is the analog input at the analog input channel number 1 of the logic controller.
		%IW0.x0y	–	Displays the address of the analog output channel on the cartridge, where x is the cartridge number and y is the channel number.
Symbol	Yes	–	–	The symbol associated with this address. Double-click in the Symbol column and type the name of the symbol to associate with this input. If a symbol already exists, you can right-click in the Symbol column and choose Search and Replace to find and replace occurrences of this symbol throughout the program and/or program comments.
Comment	Yes	–	–	The comment associated with this address. Double-click in the Comment column and type a comment to associate with this address.

Analog Outputs (%QW)

Introduction

Analog output word objects are the digital values of the analog signals received from the logic controller using cartridges.

Two 0-10 V analog outputs and two 4-20 mA analog outputs are embedded in the cartridges TMC2AQ2C and TMC2AQ2V respectively.

Refer to TMC2 Cartridges Hardware Guide used in the configuration for more details.

Displaying Analog Output Properties

Follow these steps to display properties of the analog outputs:

Step	Action
1	Select the Tools tab in the left-hand area of the Programming window.
2	Click I/O objects > Analog outputs . Result: Analog output properties appear on the screen.

Analog Outputs Properties

This table describes each property of the analog output:

Parameter	Editable	Value	Default Value	Description
Used	No	True/False	False	Indicates whether the output channel is being referenced in a program.
Address	No	%QW0.x0y	–	Displays the address of the analog output channel on the cartridge, where x is the cartridge number and y is the channel number.
Symbol	Yes	–	–	The symbol associated with this address. Double-click in the Symbol column and type the name of the symbol to associate with this output. If a symbol already exists, you can right-click in the Symbol column and choose Search and Replace to find and replace occurrences of this symbol throughout the program and/or program comments.
Comment	Yes	–	–	The comment associated with this address. Double-click in the Comment column and type a comment to associate with this address.

Network Objects

What's in This Chapter

Input Assembly (EtherNet/IP) Objects (%QWE)	157
Output Assembly (EtherNet/IP) Objects (%IWE)	158
Input Registers (Modbus TCP) Objects (%QWM).....	159
Output Registers (Modbus TCP) Objects (%IWM).....	160
Digital Input (IOScanner) Objects (%IN)	161
Digital Output (IOScanner) Objects (%QN).....	162
Input Register (IOScanner) Objects (%IWN).....	163
Output Register (IOScanner) Objects (%QWN)	164
Modbus IOScanner Network Diagnostic Codes (%IWNS).....	166

Input Assembly (EtherNet/IP) Objects (%QWE)

Introduction

Input assembly objects are the digital values of EtherNet/IP Input assembly frames received on the logic controller.

Displaying Input Assembly Properties

Follow these steps to display properties of Input assembly objects:

Step	Action
1	Select the Tools tab in the left-hand area of the Programming window.
2	Click Network objects > Input assembly (EtherNet/IP) . Result: The properties window appears.

Input Assembly Properties

This table describes each property of an Input assembly object:

Parameter	Editable	Value	Default Value	Description
Used	No	TRUE/FALSE	FALSE	Indicates whether the object is being referenced in a program.
Address	No	%QWEi	–	The address of the Input assembly, where i is the instance identifier. For the maximum number of instances, refer to <i>Maximum Number of Objects</i> , page 31.
Symbol	Yes	–	–	The symbol associated with this address. Double-click in the Symbol column and type the name of the symbol to associate with this object. If a symbol already exists, you can right-click in the Symbol column and choose Search and Replace to find and replace occurrences of this symbol throughout the program and/or program comments.
Fallback value	Yes	-32768...32767	0	Specify the value to apply to this object when the logic controller enters the <i>STOPPED</i> or an exception state. NOTE: If Maintain values fallback mode is configured, the object retains its value when the logic controller enters the <i>STOPPED</i> or an exception state. The value 0 is displayed and cannot be edited. For more details, refer to <i>Fallback Behavior</i> (see <i>EcoStruxure Machine Expert - Basic, Operating Guide</i>).
Comment	Yes	–	–	A comment associated with this object. Double-click in the Comment column and type an optional comment to associate with this object.

Output Assembly (EtherNet/IP) Objects (%IWE)

Introduction

Output assembly objects are the digital values of EtherNet/IP Output assembly frames received on the logic controller.

Displaying Output Assembly Properties

Follow these steps to display properties of Output assembly objects:

Step	Action
1	Select the Tools tab in the left-hand area of the Programming window.
2	Click Network objects > Output assembly (EtherNet/IP) . Result: The properties window appears.

Output Assembly Properties

This table describes each property of an Output assembly object:

Parameter	Editable	Value	Default value	Description
Used	No	TRUE/FALSE	FALSE	Indicates whether the object is being referenced in a program.
Address	No	%IWEi	–	The address of the Output assembly, where i is the instance identifier. For the maximum number of instances, refer to <i>Maximum Number of Objects</i> , page 31.
Symbol	Yes	–	–	The symbol associated with this address. Double-click in the Symbol column and type the name of the symbol to associate with this object. If a symbol already exists, you can right-click in the Symbol column and choose Search and Replace to find and replace occurrences of this symbol throughout the program and/or program comments.
Comment	Yes	–	–	A comment associated with this object. Double-click in the Comment column and type an optional comment to associate with this object.

Input Registers (Modbus TCP) Objects (%QWM)

Introduction

Input registers objects are the digital values of Modbus TCP mapping table input registers received on the logic controller.

Displaying Input Registers Properties

Follow these steps to display properties of Input registers objects:

Step	Action
1	Select the Tools tab in the left-hand area of the Programming window.
2	Click Network objects > Input registers (Modbus TCP) . Result: The properties window appears.

Input Registers Properties

This table describes each property of an Input registers object:

Parameter	Editable	Value	Default value	Description
Used	No	TRUE/FALSE	FALSE	Indicates whether the object is being referenced in a program.
Address	No	%QWMi	–	The address of the Input registers object, where i is the instance identifier. For the maximum number of instances, refer to <i>Maximum Number of Objects</i> , page 31.
Symbol	Yes	–	–	The symbol associated with this address. Double-click in the Symbol column and type the name of the symbol to associate with this object. If a symbol already exists, you can right-click in the Symbol column and choose Search and Replace to find and replace occurrences of this symbol throughout the program and/or program comments.
Fallback value	Yes	-32768...32767	0	Specify the value to apply to this object when the logic controller enters the <i>STOPPED</i> or an exception state. NOTE: If Maintain values fallback mode is configured, the object retains its value when the logic controller enters the <i>STOPPED</i> or an exception state. The value 0 is displayed and cannot be edited. For more details, refer to <i>Fallback Behavior</i> (see <i>EcoStruxure Machine Expert - Basic, Operating Guide</i>).
Comment	Yes	–	–	A comment associated with this object. Double-click in the Comment column and type an optional comment to associate with this object.

Output Registers (Modbus TCP) Objects (%IWM)

Introduction

Output registers objects are the digital values of Modbus TCP mapping table output registers received on the logic controller.

Displaying Output Registers Properties

Follow these steps to display properties of Output registers objects:

Step	Action
1	Select the Tools tab in the left-hand area of the Programming window.
2	Click Network objects > Output registers (Modbus TCP) . Result: The properties window appears.

Output Registers Properties

This table describes each property of an Output registers object:

Parameter	Editable	Value	Default value	Description
Used	No	TRUE/FALSE	FALSE	Indicates whether the object is being referenced in a program.
Address	No	%IWMi	–	The address of the Output registers object, where i is the instance identifier. For the maximum number of instances, refer to <i>Maximum Number of Objects</i> , page 31.
Symbol	Yes	–	–	The symbol associated with this address. Double-click in the Symbol column and type the name of the symbol to associate with this object. If a symbol already exists, you can right-click in the Symbol column and choose Search and Replace to find and replace occurrences of this symbol throughout the program and/or program comments.
Comment	Yes	–	–	A comment associated with this object. Double-click in the Comment column and type an optional comment to associate with this object.

Digital Input (IOScanner) Objects (%IN)

Introduction

Digital input (IOScanner) objects are the digital values received from Modbus Serial IOScanner or Modbus TCP IOScanner devices.

Displaying Digital inputs (IOScanner) Properties

Follow these steps to display properties of Digital inputs (IOScanner) objects:

Step	Action
1	Select the Tools tab in the left-hand area of the Programming window.
2	Click Network objects > Digital inputs (IOScanner) . Result: The properties window appears.

Digital inputs (IOScanner) Properties

This table describes each property of an Digital inputs (IOScanner) object:

Parameter	Editable	Value	Default value	Description
Used	No	TRUE/ FALSE	FALSE	Indicates whether the object is being referenced in the program.
Address	No	%IN(i+x).y.z)	–	The address of the object, where: <ul style="list-style-type: none"> i: index: <ul style="list-style-type: none"> 100 for SL1 200 for SL2 300 for ETH1 (Modbus TCP IOScanner) x: device ID y: channel ID z: object instance identifier For the maximum number of instances, refer to <i>Maximum Number of Objects</i> , page 31.
Channel	No	Name of the configured channel.	-	The name of the channel being used to receive the data from the device.
Symbol	Yes	–	–	The symbol associated with this address. Double-click in the Symbol column and type the name of the symbol to associate with this object. If a symbol already exists, you can right-click in the Symbol column and choose Search and Replace to find and replace occurrences of this symbol throughout the program and/or program comments.
Comment	Yes	–	–	A comment associated with this object. Double-click in the Comment column and type an optional comment to associate with this object.

Digital Output (IOScanner) Objects (%QN)

Introduction

Digital output (IOScanner) objects are the digital values sent to Modbus Serial IOScanner or Modbus TCP IOScanner devices.

Displaying Digital outputs (IOScanner) Properties

Follow these steps to display properties of Digital outputs (IOScanner) objects:

Step	Action
1	Select the Tools tab in the left-hand area of the Programming window.
2	Click Network objects > Digital outputs (IOScanner) . Result: The properties window appears.

Digital outputs (IOScanner) Object Properties

This table describes each property of a Digital outputs (IOScanner) object:

Parameter	Editable	Value	Default value	Description
Used	No	TRUE/FALSE	FALSE	Indicates whether the object is being referenced in a program.
Address	No	%QN(i+x).y.z	–	<p>The address of the object, where:</p> <ul style="list-style-type: none"> • i: index: <ul style="list-style-type: none"> ◦ 100 for SL1 ◦ 200 for SL2 ◦ 300 for ETH1(Modbus TCP IOScanner) • x: device ID • y: channel ID • z: object instance identifier <p>For the maximum number of instances, refer to <i>Maximum Number of Objects</i>, page 31.</p>
Channel	Yes	Name of the configured channel.	-	The name of the channel being used to send the data to the device.
Fallback value	Yes	0 or 1	0	<p>Specify the value to apply to this object when the logic controller enters the <i>STOPPED</i> or an exception state.</p> <p>NOTE: If Maintain values fallback mode is configured, the object retains its value when the logic controller enters the <i>STOPPED</i> or an exception state. The value 0 is displayed and cannot be edited. For more details, refer to <i>Fallback Behavior</i>.</p>
Symbol	Yes	–	–	<p>The symbol associated with this address.</p> <p>Double-click in the Symbol column and type the name of the symbol to associate with this object.</p> <p>If a symbol already exists, you can right-click in the Symbol column and choose Search and Replace to find and replace occurrences of this symbol throughout the program and/or program comments.</p>
Comment	Yes	–	–	<p>A comment associated with this object.</p> <p>Double-click in the Comment column and type an optional comment to associate with this object.</p>

Input Register (IOScanner) Objects (%IWN)

Introduction

Input register (IOScanner) objects are the register values received from Modbus Serial IOScanner or Modbus TCP IOScanner devices.

Displaying Input registers (IOScanner) Properties

Follow these steps to display properties of Input registers (IOScanner) objects:

Step	Action
1	Select the Tools tab in the left-hand area of the Programming window.
2	Click Network objects > Input registers (IOScanner) . Result: The properties window appears.

Input registers (IOScanner) Properties

This table describes each property of an Input registers (IOScanner) object:

Parameter	Editable	Value	Default value	Description
Used	No	TRUE/FALSE	FALSE	Indicates whether the object is being referenced in the program.
Address	No	%IWN(i+x).y.z	–	The address of the object, where: <ul style="list-style-type: none"> i: index: <ul style="list-style-type: none"> 100 for SL1 200 for SL2 300 for ETH1(Modbus TCP IOScanner) x: device ID y: channel ID z: object instance identifier For the maximum number of instances, refer to <i>Maximum Number of Objects</i> , page 31.
Channel	No	Name of the configured channel.	-	The name of the channel being used to receive the data from the device.
Symbol	Yes	–	–	The symbol associated with this address. Double-click in the Symbol column and type the name of the symbol to associate with this object. If a symbol already exists, you can right-click in the Symbol column and choose Search and Replace to find and replace occurrences of this symbol throughout the program and/or program comments.
Comment	Yes	–	–	A comment associated with this object. Double-click in the Comment column and type an optional comment to associate with this object.

Output Register (IOScanner) Objects (%QWN)

Introduction

Output register (IOScanner) objects are the register values sent to Modbus Serial IOScanner or Modbus TCP IOScanner devices.

Displaying Output registers (IOScanner) Properties

Follow these steps to display properties of Output registers (IOScanner) objects:

Step	Action
1	Select the Tools tab in the left-hand area of the Programming window.
2	Click Network objects > Output registers (IOScanner) . Result: The properties window appears.

Output registers (IOScanner) Object Properties

This table describes each property of a Output registers (IOScanner) object:

Parameter	Editable	Value	Default value	Description
Used	No	TRUE/FALSE	FALSE	Indicates whether the object is being referenced in a program.
Address	No	%QWN(i+x).y.z	–	The address of the object, where: <ul style="list-style-type: none"> • i: index: <ul style="list-style-type: none"> ◦ 100 for SL1 ◦ 200 for SL2 ◦ 300 for ETH1(Modbus TCP IOScanner) • x: device ID • y: channel ID • z: object instance identifier For the maximum number of objects, refer to <i>Maximum Number of Objects</i> , page 31.
Channel	Yes	Name of the configured channel.	-	The name of the channel being used to send the data to the device.
Fallback value	Yes	-32768...32767	0	Specify the value to apply to this object when the logic controller enters the <i>STOPPED</i> or an exception state. NOTE: If Maintain values fallback mode is configured, the object retains its value when the logic controller enters the <i>STOPPED</i> or an exception state. The value 0 is displayed and cannot be edited. For more details, refer to <i>Fallback Behavior</i> (see <i>EcoStruxure Machine Expert - Basic, Operating Guide</i>).
Symbol	Yes	–	–	The symbol associated with this address. Double-click in the Symbol column and type the name of the symbol to associate with this object. If a symbol already exists, you can right-click in the Symbol column and choose Search and Replace to find and replace occurrences of this symbol throughout the program and/or program comments.
Comment	Yes	–	–	A comment associated with this object. Double-click in the Comment column and type an optional comment to associate with this object.

Modbus IOScanner Network Diagnostic Codes (%IWNS)

Device Diagnostic Codes

The following table shows the possible values of the diagnostic codes returned by device *x* in the corresponding Modbus IOScanner network diagnostic object (%IWNS(100+*x*) for SL1, or %IWNS(200+*x*) for SL2, %IWNS(300+*x*) for ETH1):

Value	Description
0	Device not scanned.
1	Device is being initialized by Modbus IOScanner (Initialization request of device being sent).
2	Device is present and ready to be scanned (initialization requests sent, if any).
3	Device not scanned correctly due to a communication error detected on a channel of the device.
4	Device not initialized correctly due to a communication error detected during initialization request of the device.
5	Device not correctly identified because the vendor name or product code returned by the device does not match the expected values.
6	Communication error occurred during identification and initialization. Possible reasons are: incommunicative or absent device, incorrect communication parameters, or unsupported Modbus function.

Channel Diagnostic Codes

The following table shows the possible values of the diagnostic codes returned by device *x* and channel *y* in the corresponding Modbus IOScanner network diagnostic object (%IWNS(100+*x*).*y* for SL1, %IWNS(200+*x*).*y* for SL2, %IWNS(300+*x*).*y* for ETH1):

Value	Description
>0	Value of Modbus Exception Code. Operation Error Code (Modbus Exception Code) (see EcoStruxure Machine Expert - Basic, Generic Functions Library Guide)
0	Channel is active
-1	Channel is inactive
<-1	Value of the Communication Error Code (CommError) (see EcoStruxure Machine Expert - Basic, Generic Functions Library Guide) Examples: <ul style="list-style-type: none"> Diagnostic code value = -15 = -(1+ CommError error code 14) → <i>BadLength</i> Diagnostic code value = -2 = -(1 + CommError error code 1) → <i>TimeOut</i>

System Objects

What's in This Chapter

System Bits (%S)	167
System Words (%SW)	174
Input Channel Status (%IWS).....	189
Output Channel Status (%QWS).....	191

System Bits (%S)

Introduction

This section provides information about the function of system bits.

Displaying System Bits Properties

Follow these steps to display properties of the system bits:

Step	Action
1	Select the Tools tab in the left-hand area of the Programming window.
2	Click System objects > System Bits . Result: System bit properties appear on the screen.

System Bits Properties

This table describes each property of the system bit:

Parameter	Edita-ble	Value	Default Value	Description
Used	No	TRUE/FALSE	FALSE	Indicates whether the system bit is being referenced in a program.
Address	No	%Si	–	Displays the system bit address, where <i>i</i> is the bit number that represents the sequential position of the system bit in the memory. If the controller has maximum <i>n</i> system bits, the value of <i>i</i> is given as 0... <i>n</i> -1. For example, %S4 is system bit 4.
Symbol	Yes	–	–	The symbol associated with the system bit. Double-click in the Symbol column and type the name of the symbol to associate with the system bit. If a symbol already exists, you can right-click in the Symbol column and choose Search and Replace to find and replace occurrences of the symbol throughout the program and/or program comments.
Comment	Yes	–	–	A comment associated with the system bit. Double-click in the Comment column and type an optional comment to associate with the system bit.

System Bits Description

This table presents the description of the system bits and how they are controlled:

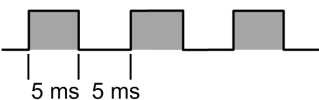
System Bit	Function	Description	Init State	Control
%S0	Cold Start	Normally set to 0, it is set to 1 by: <ul style="list-style-type: none"> A power return with loss of data (battery malfunction), The program or an animation table. This bit is set to 1 during the first complete scan. It is reset to 0 by the system before the next scan.	0	S or U→S, SIM
%S1	Warm Start	Normally set to 0. It is set to 1 by a power return with data backup, by a program or an animation table. It is reset to 0 by the system at the end of the complete scan.	0	S and U
%S4 %S5 %S6 %S7	Time base: 10 ms Time base: 100 ms Time base: 1 s Time base: 1 min	The rate of status changes is measured by an internal clock. They are not synchronized with the controller scan. Example: %S4  <p>The diagram shows a digital signal with three rectangular pulses. The first pulse starts at a certain point, followed by a 5 ms interval, then a second pulse, followed by another 5 ms interval, and then a third pulse. The intervals between the pulses are labeled as 5 ms.</p>	–	S, SIM (except %S4)
%S9	Fallback outputs	When %S9 is set to 1: <ul style="list-style-type: none"> For outputs configured as Status Alarms, PTO, or FREQGEN, the outputs are set to 0. Fallback values are applied to the physical digital and analog outputs (embedded outputs, TM2/TM3 expansion module outputs and TMC2 cartridge outputs). The data image is unaffected by %S9. The data image reflects the logic applied by the application. Only the physical outputs are affected. The fallback values are applied regardless of the fallback behavior (see EcoStruxure Machine Expert - Basic, Operating Guide) mode configured for specific outputs. When %S9 is set to 0, the data image values are re-applied to the physical outputs. NOTE: When the controller is in the <i>STOPPED</i> state and Maintain values fallback behavior is configured, a rising edge on %S9 applies fallback values to the physical outputs and to data image values.	0	U
%S10	I/O communication status	Normally set to 1 (TRUE on control panel). This bit can be set to 0 (FALSE on control panel) by the system when an I/O communication interruption is detected. When %S10=0, the ERR LED flashes.	1	S
%S11	Watchdog overflow	Normally set to 0. This bit can be set to 1 by the system when the program execution time (scan time) exceeds the maximum scan time (application watchdog). Watchdog overflow causes the controller state to change to <i>HALTED</i> . %S11 is also set to 1 by the system if the processing load is greater than 80% of the processing capacity (refer to %SW75, page 174). If the processor load is greater than 80% on any two consecutive measurements, the controller goes to <i>HALTED</i> state. Otherwise, %S11 is reset.	0	S
%S12	Logic controller in <i>RUNNING</i> state	This bit indicates that the controller is <i>RUNNING</i> . The system sets the bit to: <ul style="list-style-type: none"> 1 when the controller state is <i>RUNNING</i>, 0 for <i>STOPPED</i>, <i>BOOTING</i>, or any other state. 	0	S, SIM
%S13	First cycle in <i>RUNNING</i> state	Normally set to 0. Set to 1 by the system during the first scan after the controller state has been changed to <i>RUNNING</i> .	0	S, SIM
%S14	I/O force activated	Normally set to 0. Set to 1 by the system if at least one input or output is being forced.	0	S, SIM
%S15	Input forced	Normally set to 0. Set to 1 by the system if at least one input is being forced.	0	S, SIM
%S16	Output forced	Normally set to 0. Set to 1 by the system if at least one output is being forced.	0	S, SIM

System Bit	Function	Description	Init State	Control
%S17	Last ejected bit	Normally set to 0. It is set by the system according to the value of the last ejected bit. It indicates the value of the last ejected bit.	0	S→U, SIM
%S18	Arithmetic overflow or error	Normally set to 0. It is set to 1 in the case of an overflow when a 16-bits operation is performed, that is: <ul style="list-style-type: none"> • A result greater than + 32767 or less than - 32768, in single length, • A result greater than + 2147483647 or less than - 2147483648, in double length, • A result greater than + 3.402824E+38 or less than - 3.402824E+38, in floating point, • Division by 0, • The square root of a negative number, • BTI or ITB conversion not significant: BCD value out of limits. It must be tested by the program after each operation where there is a risk of an overflow; then reset to 0 by the program if an overflow occurs.	0	S→U, SIM
%S19	Scan period overrun (periodic scan)	Normally set to 0, this bit is set to 1 by the system in the event of a scan period overrun (scan time greater than the period defined by the program at configuration or programmed in %SW0). This bit is reset to 0 by the program.	0	S→U
%S20	Index overflow	Normally set to 0, it is set to 1 when the address of the indexed object becomes less than 0 or more than the maximum size of an object. It must be tested by the program after each operation where there is a risk of overflow; then reset to 0 if an overflow occurs.	0	S→U, SIM
%S21	Grafcet initialization	Normally set to 0, it is set to 1 by: <ul style="list-style-type: none"> • A cold restart, %S0 = 1, • The program, in the preprocessing program part only, using a Set Instruction (S %S21) or a set coil -(S)- %S21, • The terminal. At state 1, it causes Grafcet initialization. Active steps are deactivated and initial steps are activated. It is reset to 0 by the system after Grafcet initialization.	0	U→S, SIM
%S22	Grafcet reset	Normally set to 0, it can only be set to 1 by the program in preprocessing. At state 1, it causes the active steps of the entire Grafcet to be deactivated. It is reset to 0 by the system at the start of the execution of the sequential processing.	0	U→S, SIM
%S23	Preset and freeze Grafcet (List)	Normally set to 0, it can only be set to 1 by the program in the preprocessing program module. Set to 1, it validates the pre-positioning of Grafcet (List). Maintaining this bit at 1 freezes Grafcet (List) execution. It is reset to 0 by the system at the start of the execution of the sequential processing.	0	U→S, SIM
%S28	String overflow	Set to 1, it indicates that there is an overflow in a memory object when managing strings.	0	S→U, SIM
%S32	Device reset using Ethernet/IP protocol	This system bit enables the device reset using the CIP identity object in the Ethernet/IP protocol: <ul style="list-style-type: none"> • Set to 0: disabled (default). • Set to 1: enabled. 	0	U

System Bit	Function	Description	Init State	Control
%S33	Read or Write selection for Ethernet server configuration read/change	<p>Normally set to 0.</p> <ul style="list-style-type: none"> Set to 0, the %SW33 to %SW38 contains the Ethernet parameters in use (IP declared or IP assigned by BOOTP or automatic IP self assigned). These parameters are those configured in the application or those of the post configuration in SD card (in this case, %SW98 or %SW99 or %SW100 is different from 0). Set to 1 (if there is no post configuration in use), then the new configuration is given by %SW33 to %SW38. <p>This bit can be set to its initial state 0 by the program and the system (on cold restart). Then, the Ethernet is reset to apply the application configuration whatever the current configuration is.</p> <p>This bit cannot be set to 1 if a post configuration is in use.</p>	0	U→S
%S34	Ethernet Autonegotiation	<p>Set to 0 to allow the autonegotiation of the speed and half or full duplex mode.</p> <p>Set to 1 to force some specific configuration set in %S35 and %S36.</p> <p>NOTE: A modification in the state of %S34, %S35, or %S36 provokes a reinitialization of the Ethernet channel. As a consequence, the Ethernet channel may not be available for several seconds after the modification.</p>	0	U
%S35	Ethernet half/full duplex mode	<p>In case of the %S34 = 0 (autonegotiation) this bit will be set by the system, and it will be read only for the user. But is the %S34 = 1, the mode will be forced based on the value of this bit set by the user:</p> <ul style="list-style-type: none"> Set to 0 if Half Duplex, Set to 1 if Full Duplex. <p>NOTE: A modification in the state of %S34, %S35, or %S36 provokes a reinitialization of the Ethernet channel. As a consequence, the Ethernet channel may not be available for several seconds after the modification.</p>	–	U or S
%S36	Ethernet speed	<p>In case of the %S34 = 0 (autonegotiation) this bit will be set by the system, and it will be read only for the user. But is the %S34 = 1, the mode will be forced based on the value of this bit set by the user:</p> <ul style="list-style-type: none"> Set to 0 if 10 Mbps, Set to 1 if 100 Mbps. <p>NOTE: A modification in the state of %S34, %S35, or %S36 provokes a reinitialization of the Ethernet channel. As a consequence, the Ethernet channel may not be available for several seconds after the modification.</p>	–	U or S
%S38	Permission for events to be placed in the events queue	<p>Normally set to 1.</p> <ul style="list-style-type: none"> Set to 0, events cannot be placed in the events queue. Set to 1, events are placed in the events queue as soon as they are detected, <p>This bit can be set to its initial state 1 by the program and the system (on cold restart).</p>	1	U→S
%S39	Saturation of the events queue	<p>Normally set to 0.</p> <ul style="list-style-type: none"> Set to 0, all events are reported. Set to 1, at least one event is lost. <p>This bit can be set to 0 by the program and the system (on cold restart).</p>	0	U→S
%S49	Output rearming, page 45	<p>Normally set to 0, this bit can be set to 1 or 0 by the program.</p> <ul style="list-style-type: none"> Set to 0, the automatic re-arming of outputs following a short circuit is disabled. Set to 1, the automatic re-arming of outputs following a short circuit is enabled. <p>NOTE: The bit is reset to 0 on a cold start; otherwise, the bit value is retained.</p> <p>The system bit %S10 can be used to detect within your program that an output error has occurred. You can then use the system word %SW139 to determine programmatically in which cluster of outputs a short circuit or overload has occurred.</p> <p>NOTE: %S10 and %SW139 are reset to their initial state when %S49 is set to 1.</p>	0	U→S

System Bit	Function	Description	Init State	Control
%S50	Updating the date and time using words %SW49 to %SW53	<p>Normally set to 0, this bit can be set to 1 or 0 by the program.</p> <ul style="list-style-type: none"> Set to 0, the date and time can be read. Set to 1, the date and time can be updated but not read. <p>While %S50 is set to 1, the controller date and time are no longer updated by the system and cannot be read by the user program.</p> <p>The internal RTC controller is updated on a falling edge of %S50.</p> <p>Process details:</p> <ul style="list-style-type: none"> If %S50=0, the controller regularly updates the system words %SW49-53 from its internal clock. Reading %SW49-53 then provides the controller internal date & time. Setting %S50 to 1 stops this update and allows to write to %SW49-53 without being overwritten by the above process. When the controller detects a falling edge of %S50 (from 1 to 0), it applies the values of %SW49-53 to its internal clock and restarts the update of %SW49-53. <p>This %S50 process is also the mechanism used by EcoStruxure Machine Expert - Basic to update the controller time from the RTC management view. So if EcoStruxure Machine Expert - Basic detects that %S50 is already set to 1, a message informs that EcoStruxure Machine Expert - Basic cannot read the exact value of the controller internal clock. However, this situation does not prevent updates to the controller date & time from the RTC management view but, if used, %S50 will be reset by EcoStruxure Machine Expert - Basic.</p>	0	U→S
%S51	Time-of-day clock status	<p>Normally set to 0, this bit can be set to 1 or 0 by the program.</p> <ul style="list-style-type: none"> Set to 0, the date and time are consistent. Set to 1, the date and time must be initialized by the program. <p>When this bit is set to 1, the time of day clock data is not valid. The date and time may never have been configured, the battery may be low, or the controller correction constant may be invalid (never configured, difference between the corrected clock value and the saved value, or value out of range).</p> <p>State 1 transitioning to state 0 forces a Write of the correction constant to the RTC.</p>	0	U→S, SIM
%S52	RTC write error detected	This bit, managed by the system, is set to 1 to indicate that an RTC write (requested by %S50) has not been performed because of invalid values in %SW49 to %SW53, page 175. This bit is set to 0 if the requested RTC change has been correctly applied.	0	S, SIM
%S59	Updating the date and time using word %SW59	<p>Normally set to 0, this bit can be set to 1 or 0 by the program.</p> <ul style="list-style-type: none"> Set to 0, the system word %SW59 is not managed, Set to 1, the date and time are incremented or decremented according to the rising edges on the control bits set in %SW59. 	0	U
%S66	Battery LED	If the battery is missing or in error, the battery LED is ON. Set this bit to 1 to deactivate the battery LED. This system bit is set to 0 at the start.	0	U→S
%S75	Battery status	<p>This system bit is set by the system and can be read by the user. It indicates the battery status:</p> <ul style="list-style-type: none"> Set to 0, the external battery is operating normally. Set to 1, external battery power is low, or no external battery is detected. 	0	S
%S90	Backup/Restore/Erase destination	<p>This system bit selects the destination of the memory words backup/restore/erase operation:</p> <ul style="list-style-type: none"> Set to 0: non-volatile memory (default). Set to 1: SD card. 	0	U
%S91	Erase backed up variables	Set this bit to 1 to erase the backed up variables stored in non-volatile memory or the SD card, depending on %S90.	–	U→S
%S92	%MW variables backed up in non-volatile memory	This system bit is set to 1 by the system if memory word (%MW) variables are available in non-volatile memory.	–	S
%S93	Back up %MW	Set this bit to 1 to back up the %MW variables in the non-volatile memory or SD card, depending on %S90.	–	U→S
%S94	Restore %MW	Set this bit to 1 to restore the data backed up in non-volatile memory or SD card, depending on %S90.	–	U→S

System Bit	Function	Description	Init State	Control
%S96	Backup program OK	This bit can be read at any time (either by the program or while adjusting), in particular after a cold start or a warm restart. <ul style="list-style-type: none"> Set to 0, the backup program is invalid. Set to 1, the backup program is valid. 	0	S, SIM
%S101	Changing a port address (Modbus protocol)	Used to change a serial line port address using system words %SW101 (SL1) and %SW102 (SL2). To do this, %S101 must be set to 1. <ul style="list-style-type: none"> Set to 0, the address cannot be changed. The value of %SW101 and %SW102 matches the current port address, Set to 1, the address can be changed by changing the values of %SW101 (SL1) and %SW102 (SL2). NOTE: %S101 cannot be set to 1 if a post configuration file is defined on SL1 or SL2.	0	U
%S103 %S104	Using the ASCII protocol	Enables the use of the ASCII protocol on SL1 (%S103) or SL2 (%S104). The ASCII protocol is configured using system words %SW103 and %SW105 for SL1, and system words %SW104 and %SW106 for SL2. <ul style="list-style-type: none"> Set to 0, the protocol used is the one configured in EcoStruxure Machine Expert - Basic, or specified in the post configuration, page 49. Set to 1, the ASCII protocol is used on SL1 (%S103) or SL2 (%S104). In this case, the system words %SW103, %SW105, and %SW121 must be previously configured for SL1, and %SW104, %SW106, and %SW122 for SL2. Each change of those %SW will be taken into account after a rising edge to %S103 or %S104. NOTE: A rising or falling edge on %S103 or %S104 cancels an exchange in progress (<i>EXCH</i> instruction). NOTE: Setting %S103 or %S104 to 0 reconfigures the serial line with the EcoStruxure Machine Expert - Basic parameters. NOTE: %S103 and %S104 are ignored if a Modbus Serial Line IOScanner is configured on the corresponding serial line.	0	U
%S105	Modem initialization command	Set to 1 to send the initialization command to the modem. Reset to 0 by the system. See also %SW167, page 174.	0	U/S
%S106	I/O bus behavior	The default value is 0, meaning that a bus communication error on an expansion module, page 86 stops the I/O expansion bus exchanges. Set this bit to 1 to specify that the controller continues to make I/O expansion bus exchanges. NOTE: When a bus communication error occurs, bit n of %SW120 is set to 1, where n is the expansion module number, and %SW118 bit 14 is set to 0. For more information on bus error handling, refer to I/O Configuration General Description, page 86.	0	U/S
%S107	I/O bus restart	The default value is 0. Reset to 0 by the system. Set this bit to 1 to force a restart of the I/O expansion bus, page 88. On detection of a rising edge of this bit, the logic controller reconfigures and restarts the I/O expansion bus if: <ul style="list-style-type: none"> %S106 is set to 0 (that is, I/O exchanges are stopped) %SW118 bit 14 is set to 0 (I/O bus is in error) At least one bit of %SW120 is set to 1 (identifying the module that is in bus communication error) For more information on bus error handling, refer to I/O Configuration General Description, page 86.	0	U/S
%S110	IOScanner reset SL1	Set to 1 to reset the Modbus Serial IOScanner on Serial Line 1.	0	U/S
%S111	IOScanner reset SL2	Set to 1 to reset the Modbus Serial IOScanner on Serial Line 2.	0	U/S
%S112	IOScanner reset ETH1	Set to 1 to reset the Modbus TCP IOScanner on Ethernet.	0	U/S
%S113	IOScanner suspend SL1	Set to 1 to suspend the Modbus Serial IOScanner on Serial Line 1.	0	U/S
%S114	IOScanner suspend SL2	Set to 1 to suspend the Modbus Serial IOScanner on Serial Line 2.	0	U/S
%S115	IOScanner suspend ETH1	Set to 1 to suspend the Modbus TCP IOScanner on Ethernet.	0	U/S
%S119	Local I/O error detected	Normally set to 1. This bit can be set to 0 when an I/O communication interruption is detected on the logic controller. %SW118 determines the nature of the communication interruption. Resets to 1 when the communication interruption disappears.	1	S

System Bit	Function	Description	Init State	Control
%S122	Automatically switch to Alarm page	Set to 1, the Remote Graphic Display automatically switches to the Alarm page when a rising edge is detected on an alarm bit.	0	U
%S123	Display red backlight on alarm	Set to 1, the backlight on the Remote Graphic Display is red when an alarm is active.	0	U

S Controlled by the system
U Controlled by the user
U→S Set to 1 by the user, reset to 0 by the system
S→U Set to 1 by the system, reset to 0 by the user
SIM Applied in the Simulator

System Words (%SW)

Introduction

This section provides information about the function of system words.

Displaying System Words Properties

Follow these steps to display properties of the system words:

Step	Action
1	Select the Tools tab in the left-hand area of the Programming window.
2	Click System objects > System Words . Result: System word properties appear on the screen.

System Words Properties

This table describes each property of the system word:

Parameter	Edit-able	Value	Default Value	Description
Used	No	TRUE/FALSE	FALSE	Indicates whether the system word is being referenced in a program.
Address	No	%SWi	–	Displays the system word address, where i is the word number that represents the sequential position of the system word in the memory. If the controller has maximum n system words, the value of i is given as 0...n-1. For example, %SW50 is system word 50.
Symbol	Yes	–	–	The symbol associated with the system word. Double-click in the Symbol column and type the name of the symbol to associate with the system word. If a symbol already exists, you can right-click in the Symbol column and choose Search and Replace to find and replace occurrences of the symbol throughout the program and/or program comments.
Comment	Yes	–	–	A comment associated with the system word. Double-click in the Comment column and type an optional comment to associate with the system word.

System Words Description

This table presents the description of the system words and how they are controlled:

System Words	Function	Description	Control
%SW0	Controller scan period (master task set to periodic scan mode)	Modifies the controller scan period (1...150 ms) defined in the Master task properties (see EcoStruxure Machine Expert - Basic, Operating Guide) or an animation table.	U, SIM
%SW1	Periodic task period	<p>Modifies the cycle time [1...255 ms] of the periodic task, without losing the Period value specified in the periodic task properties window.</p> <p>Allows you to recover the Period value saved in the periodic task properties window:</p> <ul style="list-style-type: none"> • in case of a cold start, or • if the value you write in %SW1 is outside [1...255] range. <p>The %SW1 value can be modified in the program at each end of a cycle, in the program or in an animation table without having to stop the program. Cycle times can be correctly observed while the program is running.</p>	U, SIM
%SW6	Controller state %MW60012	<p>Controller state:</p> <p>0 = <i>EMPTY</i></p> <p>2 = <i>STOPPED</i></p> <p>3 = <i>RUNNING</i></p> <p>4 = <i>HALTED</i></p> <p>5 = <i>POWERLESS</i></p>	S, SIM
%SW7	Controller status	<ul style="list-style-type: none"> • Bit [0]: Backup/restore in progress: <ul style="list-style-type: none"> ◦ Set to 1 if backup/restore of the program is in progress, ◦ Set to 0 if backup/restore of the program is complete or disabled. • Bit [1]: Configuration of the controller is OK: <ul style="list-style-type: none"> ◦ Set to 1 if configuration ok. • Bit [2]: SD card status bits: <ul style="list-style-type: none"> ◦ Set to 1 if SD card is present. • Bit [3]: SD card status bits: <ul style="list-style-type: none"> ◦ Set to 1 if SD card is being accessed. • Bit [4]: Application memory status: <ul style="list-style-type: none"> ◦ Set to 1 if application in RAM memory is different from that in non-volatile memory. • Bit [5]: SD card status bits: <ul style="list-style-type: none"> ◦ Set to 1 if SD card is in error. • Bit [6]: Not used (status 0) • Bit [7]: Controller reserved: <ul style="list-style-type: none"> ◦ Set to 1 when the controller is connected to EcoStruxure Machine Expert - Basic. • Bit [8]: Application in Write mode: <ul style="list-style-type: none"> ◦ Set to 1 if application is protected. In this case, the clone operation does not replicate the application (refer to Clone Management, page 140). • Bit [9]: Not used (status 0) • Bit [10]: Second serial port installed as cartridge (compact only): <ul style="list-style-type: none"> ◦ 0 = No serial cartridge ◦ 1 = Serial cartridge installed • Bit [11]: Second serial port type: <ul style="list-style-type: none"> ◦ Set to 1 = EIA RS-485 • Bit [12]: Validity of the application in internal memory: <ul style="list-style-type: none"> ◦ Set to 1 if the application is valid. • Bit [14]: Validity of the application in RAM memory: <ul style="list-style-type: none"> ◦ Set to 1 if the application is valid. • Bit [15]: Ready for execution: <ul style="list-style-type: none"> ◦ Set to 1 if ready for execution. 	S, SIM

System Words	Function	Description	Control
%SW11	Software watchdog value	Contains the maximum value of the watchdog. The value (10...500 ms) is defined by the configuration.	U, SIM
%SW13	Boot loader version xx.yy	For example, if %SW13=000E hex: <ul style="list-style-type: none"> 8 MSB=00 in hexadecimal, then xx=0 in decimal 8 LSB=0E in hexadecimal, then yy=14 in decimal As a result, boot loader version is 0.14, displayed as 14 decimal.	S, SIM
%SW14	Commercial version, xx.yy	For example, if %SW14=0232 hex: <ul style="list-style-type: none"> 8 MSB=02 in hexadecimal, then xx=2 in decimal 8 LSB=32 in hexadecimal, then yy=50 in decimal As a result, commercial version is 2.50, displayed as 250 decimal.	S, SIM
%SW15-%SW16	Firmware version aa.bb.cc.dd	For example, if: <p>%SW15=0003 hex:</p> <ul style="list-style-type: none"> 8 MSB=00 in hexadecimal, then aa=00 in decimal 8 LSB=03 in hexadecimal, then bb=03 in decimal <p>%SW16=0B16 hex:</p> <ul style="list-style-type: none"> 8 MSB=0B in hexadecimal, then cc=11 in decimal 8 LSB=16 in hexadecimal, then dd=22 in decimal As a result, firmware version is 0.3.11.22 displayed as 00031122 decimal.	S, SIM
%SW17	Default status for floating operation	When an error is detected in a floating arithmetic operation, bit %S18 is set to 1 and the default status of %SW17 is updated according to the following coding: <ul style="list-style-type: none"> Bit[0]: Invalid operation, result is not a number (NaN) Bit[1]: Reserved Bit[2]: Division by 0, result is invalid (-Infinity or +Infinity) Bit[3]: Result greater in absolute value than +3.402824e+38, result is invalid (-Infinity or +Infinity). It must be tested by the program after each operation where there is a possible overflow; then reset to 0 by the program if an overflow occurs.	S and U, SIM
%SW18-%SW19	100 ms absolute timer counter	This counter works using 2 words: <ul style="list-style-type: none"> %SW18 represents the least significant word, %SW19 represents the most significant word. The %SW18 increases from 0 to 32767 each 100 ms. When 32767 is reached, %SW19 is incremented and %SW18 is reset to 0. These double word are also reset during the initialization phase and on a reset of %S0.	S and U, SIM
%SW30	Last scan time (master task)	Indicates the execution time of the last controller scan cycle (in ms). <p>NOTE: This time corresponds to the time elapsed between the start (acquisition of inputs) and the end (update of outputs) of a master task scan cycle. If the scan time is 2.250 ms, the %SW30 is 2 and the %SW70 is 250.</p>	S
%SW31	Max. scan time (master task)	Indicates the execution time of the longest controller scan cycle since the last cold start (in ms). <p>This time corresponds to the time elapsed between the start (acquisition of inputs) and the end (update of outputs) of a scan cycle. If the maximum scan time is 2.250 ms, the %SW31 will be 2 and the %SW71 will be 250.</p> <p>NOTE: To detect a pulse signal when the latching input option is selected, the pulse width (T_{ON}) and the period (P) must meet the following 2 requirements:</p> <ul style="list-style-type: none"> $T_{ON} \geq 1$ ms The input signal period (P) follows the Nyquist-Shannon sampling rule stating that the input signal period (P) is at least twice the maximum program scan time (%SW31): $P \geq 2 \times \%SW31$. 	S
%SW32	Min. scan time (master task)	Indicates the execution time of shortest controller scan cycle since the last cold start (in ms). <p>NOTE: This time corresponds to the time elapsed between the start (acquisition of inputs) and the end (update of outputs) of a scan cycle. If the minimum scan time is 2.250 ms, the %SW32 is 2 and the %SW72 is 250.</p>	S

System Words	Function	Description	Control										
%SW33 %SW34 %SW35 %SW36 %SW37 %SW38	IP address for Ethernet server configuration read/write	The IP settings can be modified. The read or write selection is done using the system bit %S33. The system words %SW33 . . . %SW38 contains the Ethernet parameters: <ul style="list-style-type: none"> IP address: %SW33 and %SW34 For IP address AA.BB.CC.DD: %SW33 = CC.DD and %SW34 = AA.BB Subnetwork mask: %SW35 and %SW36 For subnetwork mask AA.BB.CC.DD: %SW35 = CC.DD and %SW36 = AA.BB Gateway address: %SW37 and %SW38 For gateway address AA.BB.CC.DD: %SW37 = CC.DD and %SW38 = AA.BB 	U										
%SW39	Periodic average time	Indicates the average execution time in μ s of the periodic task (last 5 times).	-										
%SW40	Event 0 average time	Indicates the average execution time in μ s of the event task associated with the input %I0.2 (last 5 times).	-										
%SW41	Event 1 average time	Indicates the average execution time in μ s of the event task associated with the input %I0.3 (last 5 times).	-										
%SW42	Event 2 average time	Indicates the average execution time in μ s of the event task associated with the input %I0.4 (last 5 times).	-										
%SW43	Event 3 average time	Indicates the average execution time in μ s of the event task associated with the input %I0.5 (last 5 times).	-										
%SW44	Event 4 average time	Indicates the average execution time in μ s of the event task associated with the Threshold 0 of HSC0 or HSC2 (last 5 times).	-										
%SW45	Event 5 average time	Indicates the average execution time in μ s of the event task associated with the Threshold 1 of HSC0 or HSC2 (last 5 times).	-										
%SW46	Event 6 average time	Indicates the average execution time in μ s of the event task associated with the Threshold 0 of HSC1 or HSC3 (last 5 times).	-										
%SW47	Event 7 average time	Indicates the average execution time in μ s of the event task associated with the Threshold 1 of HSC1 or HSC3 (last 5 times).	-										
%SW48	Number of events	Indicates how many events have been executed since the last cold start. (Counts all events except cyclic events.) NOTE: Set to 0 (after application loading and cold start), increments on each event execution.	S, SIM										
%SW49 %SW50 %SW51 %SW52 %SW53	Real-Time Clock (RTC)	RTC functions: words containing current date and time values (in BCD): <table border="1" style="width: 100%; border-collapse: collapse;"> <tr> <td style="width: 50%;">%SW49</td> <td>xN Day of the week (N=1 for Monday) NOTE: %SW49 is read only (S).</td> </tr> <tr> <td>%SW50</td> <td>00SS Seconds</td> </tr> <tr> <td>%SW51</td> <td>HHMM: hour and minute</td> </tr> <tr> <td>%SW52</td> <td>MMDD: month and day</td> </tr> <tr> <td>%SW53</td> <td>CCYY: century and year</td> </tr> </table> Set system bit %S50 to 1 to enable updating the RTC value using system words %SW49 to %SW53. On a falling edge of %S50 the internal RTC controller is updated using the values written in these words. For more details, see system bit %S50, page 168.	%SW49	xN Day of the week (N=1 for Monday) NOTE: %SW49 is read only (S).	%SW50	00SS Seconds	%SW51	HHMM: hour and minute	%SW52	MMDD: month and day	%SW53	CCYY: century and year	S and U, SIM
%SW49	xN Day of the week (N=1 for Monday) NOTE: %SW49 is read only (S).												
%SW50	00SS Seconds												
%SW51	HHMM: hour and minute												
%SW52	MMDD: month and day												
%SW53	CCYY: century and year												
%SW54 %SW55 %SW56 %SW57	Date and time of the last stop	System words containing the date and time of the last power outage or controller stop (in BCD): <table border="1" style="width: 100%; border-collapse: collapse;"> <tr> <td style="width: 50%;">%SW54</td> <td>SS Seconds</td> </tr> <tr> <td>%SW55</td> <td>HHMM: hour and minute</td> </tr> <tr> <td>%SW56</td> <td>MMDD: month and day</td> </tr> <tr> <td>%SW57</td> <td>CCYY: century and year</td> </tr> </table>	%SW54	SS Seconds	%SW55	HHMM: hour and minute	%SW56	MMDD: month and day	%SW57	CCYY: century and year	S, SIM		
%SW54	SS Seconds												
%SW55	HHMM: hour and minute												
%SW56	MMDD: month and day												
%SW57	CCYY: century and year												

System Words	Function	Description	Control		
%SW58	Code of last stop	Displays code giving cause of last transition from the <i>RUNNING</i> state to another state:	S, SIM		
		0		Initial value (after a download or an initialization command)	
		1		Run/Stop input or Run/Stop switch is set to 0. A falling edge on the Run/Stop input or Run/Stop switch at 0 has been detected while the controller was in the <i>RUNNING</i> state, or the controller was powered on with the Run/Stop input or Run/Stop switch at 0.	
		2		Program error detected. A program error has been detected while the controller was in the <i>RUNNING</i> state (in which case the controller goes to the <i>HALTED</i> state), or the controller was in the <i>HALTED</i> state when the power was cycled, preventing it starting in run.	
		3		Stop command using EcoStruxure Machine Expert - Basic online button or Remote Graphic Display.	
		4		Power outage. The controller starting in run after a power cycle, or the controller is in the <i>STOPPED</i> state because the starting mode is Start in Previous State and the controller was in the <i>STOPPED</i> state when the power outage occurred.	
		5		Hardware error detected.	
		6		Not used.	
		7		Power on with starting mode configured as Start in stop .	
		8		The controller could not recover previous data that it had at last power outage (for example because the battery is low), preventing it starting in run.	
		9		Controller is not able to run due to internal memory errors.	
				The reasons for the last stop are prioritized in the following order (that is, when the controller is in the <i>STOPPED</i> state after a power cycle): 1, 7, 4, 8, 2	
%SW59	Adjust current date	Adjusts the current date.	U		
		Contains 2 sets of 8 bits to adjust current date.			
		The operation is always performed on rising edge of the bit. This word is enabled by bit %S59.			
		Increment		Decrement	Parameter
		bit 0		bit 8	Day of week
		bit 1		bit 9	Seconds
		bit 2		bit 10	Minutes
		bit 3		bit 11	Hours
		bit 4		bit 12	Days
		bit 5		bit 13	Month
bit 6	bit 14	Years			
bit 7	bit 15	Centuries			
%SW61	Ethernet hardware ID	Values and firmware compatibility are as follows: 0 - Reserved. 1 - Legacy. Compatible with all firmware versions. 2 - Type A. Compatible with firmware version 1.12.1.1 or later.	-		

System Words	Function	Description	Control
%SW62	Ethernet error detection	Indicates the error code: 0 - No error detected 1 - Duplicate IP: the M221 Logic Controller is configured with its default IP address (generated from the MAC address) 2 - DHCP in progress 3 - BOOTP in progress 4 - Invalid parameters: port is disabled 5 - Fixed IP address initialization in progress 6 - Ethernet link down	S
%SW63	EXCH1 block error code	EXCH1 error code: 0 - operation was successful 1 - number of bytes to be transmitted exceeds the limit (> 255) 2 - insufficient transmission table 3 - insufficient word table 4 - receive table overflowed 5 - time-out elapsed 6 - transmission 7 - incorrect command within table 8 - selected port not configured/available 9 - reception error: This error code reflects an incorrect or corrupted reception frame. It can be caused due to an incorrect configuration in the physical parameters (for example, parity, data bits, baudrate, and so on) or an unreliable physical connection causing signal degradation. 10 - cannot use %KW if receiving 11 - transmission offset larger than transmission table 12 - reception offset larger than reception table 13 - controller stopped EXCH processing	S
%SW64	EXCH2 block error code	EXCH2 error code: See %SW63.	S

System Words	Function	Description	Control
%SW65	EXCH3 block error code	<p>1-4, 6-13: See %SW63. (Note that error code 5 is invalid and replaced by the Ethernet-specific error codes 109 and 122 described below.)</p> <p>The following are Ethernet-specific error codes:</p> <p>101 - incorrect IP address</p> <p>102 - no TCP connection</p> <p>103 - no socket available (all connection channels are busy)</p> <p>104 - network is down</p> <p>105 - network cannot be reached</p> <p>106 - network dropped connection on reset</p> <p>107 - connection aborted by peer device</p> <p>108 - connection reset by peer device</p> <p>109 - connection time-out elapsed</p> <p>110 - rejection on connection attempt</p> <p>111 - host is down</p> <p>120 - incorrect index (remote device is not indexed in configuration table)</p> <p>121 - system error (MAC, chip)</p> <p>122 - receiving process timed-out after data was sent</p> <p>123 - Ethernet initialization in progress</p>	S
%SW67	Function and type of controller	Contains the logic controller code ID. For more information, refer to the M221 Logic Controller Code ID table, page 189.	S, SIM
%SW70	Scan time microseconds resolution	<p>Indicates the execution time of the last controller scan cycle (in μs).</p> <p>NOTE: This time corresponds to the time elapsed between the start (acquisition of inputs) and the end (update of outputs) of a master task scan cycle. If the scan time is 2.250 ms, the %SW30 will be 2 and the %SW70 will be 250.</p>	–
%SW71	Max. scan time microseconds resolution	<p>Indicates the execution time of the longest controller scan cycle since the last cold start (in ms).</p> <p>NOTE: This time corresponds to the time elapsed between the start (acquisition of inputs) and the end (update of outputs) of a scan cycle. If the scan time is 2.250 ms, the %SW31 will be 2 and the %SW71 will be 250.</p>	–
%SW72	Min. scan time microseconds resolution	<p>Indicates the execution time of the shortest controller scan cycle since the last cold start (in ms).</p> <p>NOTE: This time corresponds to the time elapsed between the start (acquisition of inputs) and the end (update of outputs) of a scan cycle. If the scan time is 2.250 ms, the %SW32 will be 2 and the %SW72 will be 250.</p>	–
%SW75	Load of processor	<p>Indicates the percentage of processing load.</p> <p>Processing load is defined as the percentage of the total available processing time that is used to process your program tasks (this value is an average and it is calculated every second). In case of processing load higher than 80% for two consecutive periods of time, the controller goes to <i>HALTED</i> state.</p>	S
%SW76 to %SW79	Down counters 1-4	These 4 words serve as 1 ms timers. They are decremented individually by the system every ms if they have a positive value. This gives 4 down counters down counting in ms which is equal to an operating range of 1 ms to 32767 ms. Setting bit 15 to 1 can stop decrementation.	S and U, SIM
%SW80	Status of embedded analog inputs	<ul style="list-style-type: none"> • Bit [0]: Set to 1 if the embedded analog inputs are operational • Bit [6]: Set to 1 if an error is detected on analog input 0 • Bit [7]: Set to 1 if an error is detected on analog input 1 • All other bits are reserved and set to 1 	S and U, SIM
%SW94 %SW95	Application signature %MW60028-%MW60034	<p>If the application changes, in terms of configuration or programming data, the signature (sum of all checksums) also changes.</p> <p>If %SW94 = 91F3 in hexadecimal, the application signature is 91F3 in hexadecimal.</p>	S, SIM

System Words	Function	Description	Control
%SW96	Diagnostics for save/restore function of program and %MW	<ul style="list-style-type: none"> • Bit [1]: This bit is set by the firmware to indicate when the save is complete: <ul style="list-style-type: none"> ◦ Set to 1 if the backup is complete. ◦ Set to 0 if a new backup is requested. • Bit [2]: Back up error detected, refer to bits 8, 9, 10, 12 and 14 for further information: <ul style="list-style-type: none"> ◦ Set to 1 if an error is detected. ◦ Set to 0 if a new backup is requested. • Bit [6]: Set to 1 if the controller contains a valid application in RAM memory. • Bit [10]: Difference detected between RAM memory and non-volatile memory. <ul style="list-style-type: none"> ◦ Set to 1 if there is a difference. • Bit [12]: Indicates if a restore error has occurred: <ul style="list-style-type: none"> ◦ Set to 1 if an error is detected. • Bit [14]: Indicates if a non-volatile memory write error has occurred: <ul style="list-style-type: none"> ◦ Set to 1 if an error is detected. 	S, SIM
%SW98	Post configuration status (Serial Line 1)	<p>The bits are set to 1 when the post configuration was applied for the parameter:</p> <ul style="list-style-type: none"> • Bit[0]: Hardware option (RS485 or RS232) • Bit[1]: Baudrate • Bit[2]: Parity • Bit[3]: Data size • Bit[4]: Number of stop bits • Bit[5]: Modbus address • Bit[6]: Polarization (if available in the port) 	S
%SW99	Post configuration status (Serial Line 2)	<p>The bits are set to 1 when the post configuration was applied for the parameter:</p> <ul style="list-style-type: none"> • Bit[0]: Hardware option (RS485) • Bit[1]: Baudrate • Bit[2]: Parity • Bit[3]: Data size • Bit[4]: Number of stop bits • Bit[5]: Modbus address • Bit[6]: Polarization (if available in the port) 	S
%SW100	Post configuration status (Ethernet)	<p>The bits are set to 1 when the post configuration was applied for the parameter:</p> <ul style="list-style-type: none"> • Bit[0]: IP mode (fixed, DHCP, or BOOTP) • Bit[1]: IP address • Bit[2]: Network submask • Bit[3]: Default gateway • Bit[4]: Device name <p>NOTE: The post configuration has priority over the configuration provided by your application. The configuration of your application is not taken into account if the M221 Logic Controller has a post configuration.</p>	S
%SW101 %SW102	Value of the Modbus address port	<p>When bit %S101 is set to 1, you can change the Modbus address of SL1 or SL2. The address of SL1 is %SW101. The address of SL2 is %SW102.</p> <p>NOTE: The update is applied immediately after writing a new address to %SW101 or %SW102.</p>	U

System Words	Function	Description	Control																																
%SW103 %SW104	Configuration for use of the ASCII protocol	<p>When bit %S103 (SL1) or %S104 (SL2) is set to 1, the ASCII protocol is used. System word %SW103 (SL1) or %SW104 (SL2) must be set according to the elements below:</p> <table border="1" style="width: 100%; border-collapse: collapse; text-align: center;"> <tr> <td>15</td><td>14</td><td>13</td><td>12</td><td>11</td><td>10</td><td>9</td><td>8</td><td>7</td><td>6</td><td>5</td><td>4</td><td>3</td><td>2</td><td>1</td><td>0</td> </tr> <tr> <td colspan="10">End of the character string</td> <td>Data bit</td> <td>Stop bit</td> <td>Parity</td> <td>RTS/CTS</td> <td colspan="2">Baud rate</td> </tr> </table> <ul style="list-style-type: none"> • Baud rate: <ul style="list-style-type: none"> ◦ 000: 1200 baud, ◦ 001: 2400 baud, ◦ 010: 4800 baud, ◦ 011: 9600 baud, ◦ 100: 19200 baud, ◦ 101: 38400 baud, ◦ 110: 57600 baud, ◦ 111: 115200 baud. • RTS/CTS: <ul style="list-style-type: none"> ◦ 0: disabled, ◦ 1: enabled. • Parity: <ul style="list-style-type: none"> ◦ 00: none, ◦ 10: odd, ◦ 11: even. • Stop bit: <ul style="list-style-type: none"> ◦ 0: 1 stop bit, ◦ 1: 2 stop bits. • Data bits: <ul style="list-style-type: none"> ◦ 0: 7 data bits, ◦ 1: 8 data bits. 	15	14	13	12	11	10	9	8	7	6	5	4	3	2	1	0	End of the character string										Data bit	Stop bit	Parity	RTS/CTS	Baud rate		S, U
15	14	13	12	11	10	9	8	7	6	5	4	3	2	1	0																				
End of the character string										Data bit	Stop bit	Parity	RTS/CTS	Baud rate																					
%SW105 %SW106	Configuration for use of the ASCII protocol	<p>When bit %S103 (SL1) or %S104 (SL2) is set to 1, the ASCII protocol is used. System word %SW105 (SL1) or %SW106 (SL2) must be set according to the elements below:</p> <table border="1" style="width: 100%; border-collapse: collapse; text-align: center;"> <tr> <td>15</td><td>14</td><td>13</td><td>12</td><td>11</td><td>10</td><td>9</td><td>8</td><td>7</td><td>6</td><td>5</td><td>4</td><td>3</td><td>2</td><td>1</td><td>0</td> </tr> <tr> <td colspan="10">Timeout frame in ms</td> <td colspan="6">Timeout response in multiples of 100 ms</td> </tr> </table>	15	14	13	12	11	10	9	8	7	6	5	4	3	2	1	0	Timeout frame in ms										Timeout response in multiples of 100 ms						S, U
15	14	13	12	11	10	9	8	7	6	5	4	3	2	1	0																				
Timeout frame in ms										Timeout response in multiples of 100 ms																									
%SW107 %SW108 %SW109	MAC address	<p>Indicates the controller MAC address (only references with Ethernet channel).</p> <p>For MAC address AA:BB:CC:DD:EE:FF:</p> <ul style="list-style-type: none"> • %SW107 = AA:BB • %SW108 = CC:DD • %SW109 = EE:FF 	S																																
%SW114	Enable schedule blocks	<p>Enables or disables operation of schedule blocks by the program:</p> <ul style="list-style-type: none"> • Bit [0]: Enable/disable schedule block number 0 <ul style="list-style-type: none"> ◦ Set to 0: disabled ◦ Set to 1: enabled • ... • Bit [15]: Enable/disable schedule block number 15 <ul style="list-style-type: none"> ◦ Set to 0: disabled ◦ Set to 1: enabled <p>Initially all schedule blocks are enabled.</p> <p>The default value is FFFF hex.</p>	S and U, SIM																																
%SW115 %SW116 %SW117	Controller serial numbers part 1, 2, and 3 respectively (in BCD)	<p>Allows to obtain the serial number of the controller.</p> <p>Example with the serial number 8A160400008:</p> <ul style="list-style-type: none"> • %SW115 : 16#0008 • %SW116 : 16#6040 • %SW117 : 16#0001 	S																																

System Words	Function	Description	Control
%SW118	Logic controller status word	<p>Indicates conditions on logic controller.</p> <p>For a controller operating normally, the value of this word is FFFF hex.</p> <ul style="list-style-type: none"> • Bit [9]: <ul style="list-style-type: none"> ◦ Set to 0: External error detected or communication interruption, for example duplicate IP address ◦ Set to 1: No error detected. • Bit [10]: <ul style="list-style-type: none"> ◦ Set to 0: Invalid internal configuration; contact Schneider Electric customer service. ◦ Set to 1: No error detected. • Bit [13]: <ul style="list-style-type: none"> ◦ Set to 0: Configuration error detected (mandatory modules, as defined by the I/O expansion bus configuration, are absent or otherwise inoperative when the logic controller attempts to start the I/O expansion bus). In this case, the I/O bus does not start. ◦ Set to 1: No error detected. • Bit [14]: <ul style="list-style-type: none"> ◦ Set to 0: One or more modules have ceased communication with the logic controller after the I/O expansion bus is started. This is the case whether an I/O expansion module is defined as mandatory or optional but present at start-up. ◦ Set to 1: No error detected. <p>For more information on bus error handling, refer to <i>I/O Configuration General Description</i>, page 86.</p> <ul style="list-style-type: none"> • Bit [15]: <ul style="list-style-type: none"> ◦ Set to 0: Cartridge error detected (configuration or runtime operation). ◦ Set to 1: No error detected. <p>NOTE: The other bits of this word are set to 1 and are reserved.</p>	S, SIM
%SW119	Optional module feature configuration	<p>One bit for each expansion module in the configuration:</p> <ul style="list-style-type: none"> • Bit [0]: Reserved for the logic controller • Bit n: Module n <ul style="list-style-type: none"> ◦ Set to 1: Module is marked as optional in the configuration. ◦ Set to 0: Module is not marked as optional in the configuration. 	S, SIM
%SW120	Expansion I/O module status	<p>1 bit for each expansion module in the configuration.</p> <p>Bit 0: Reserved for the logic controller</p> <p>When the logic controller attempts to start the I/O bus, bit n:</p> <ul style="list-style-type: none"> • 0 = no error detected • 1 = error detected or module not present. The I/O expansion bus does not start unless the corresponding bit in %SW119 is set to TRUE (indicating the module is marked as optional). <p>After the bus started and is running with data exchanges with the controller, bit n:</p> <ul style="list-style-type: none"> • 0 = no error detected • 1 = error detected on the I/O expansion module (regardless if it is a module marked as optional). <p>For more information on bus error handling, refer to <i>I/O Configuration General Description</i>, page 86.</p>	S, SIM
%SW121 %SW122	Configuration for use of ASCII protocol	<p>When bit %S103 (SL1) or %S104 (SL2) is set to 1, the ASCII protocol is used. You can change the ASCII frame size of SL1 or SL2. The ASCII frame size of SL1 is %SW121, and that of SL2 is %SW122.</p>	U

System Words	Function	Description	Control
%SW128	Cartridge 1 status	Indicates the status code for the cartridge:	S, SIM
%SW129	Cartridge 2 status	<ul style="list-style-type: none"> • LSB: presents the status of the I/O channel 1 • MSB: presents the status of the I/O channel 2 General status: <ul style="list-style-type: none"> • 0x80: Cartridge is not present and it is not configured in EcoStruxure Machine Expert - Basic. • 0x81: Module is present, but it is not configured. • 0x82: Internal communication error with the cartridge. • 0x83: Internal communication error with the cartridge. • 0x84: Detected cartridge different from the configuration. • 0x85: Configured cartridge is not detected. Input channel operation status: <ul style="list-style-type: none"> • 0x00: Normal. • 0x01: Conversion in progress. • 0x02: Initialization. • 0x03: Input operation setting error detected or module without input. • 0x04: Reserved. • 0x05: Wiring error detected (High limit range out). • 0x06: Wiring error detected (Low limit range out). • 0x07: Non-volatile memory error detected. • Others: Reserved. Output channel operation status: <ul style="list-style-type: none"> • 0x00: Normal. • 0x01: Reserved. • 0x02: Initialization. • 0x03: Output operation setting error detected or module without output. • 0x04: Reserved. • 0x05: Reserved. • 0x06: Reserved. • 0x07: Non-volatile memory error detected. • Others: Reserved. 	
%SW130	Event execution time	Indicates the last execution time in μ s of the event task associated with the input %I0.2.	S
%SW131	Event execution time	Indicates the last execution time in μ s of the event task associated with the input %I0.3.	S
%SW132	Event execution time	Indicates the last execution time in μ s of the event task associated with the input %I0.4.	S
%SW133	Event execution time	Indicates the last execution time in μ s of the event task associated with the input %I0.5.	S
%SW134	Event execution time	Indicates the last execution time in μ s of the event task associated with the Threshold 0 of HSC0 or HSC2.	S
%SW135	Event execution time	Indicates the last execution time in μ s of the event task associated with the Threshold 1 of HSC0 or HSC2.	S
%SW136	Event execution time	Indicates the last execution time in μ s of the event task associated with the Threshold 0 of HSC1 or HSC3.	S
%SW137	Event execution time	Indicates the last execution time in μ s of the event task associated with the Threshold 1 of HSC1 or HSC3.	S
%SW138	Periodic task execution time	Indicates the last execution time in μ s of the periodic task.	S
%SW139	Embedded digital output protection	Indicates the protection error status of output blocks: Bit0 = 1 - Q0 - Q3 protect error - Block0 Bit1 = 1 - Q4 - Q7 protect error - Block1 Bit2 = 1 - Q8 - Q11 protect error - Block2 Bit3 = 1 - Q12 - Q15 protect error - Block3 NOTE: %SW139 is not used for sink outputs.	S

System Words	Function	Description	Control
%SW140	Controller last error code 1	Most recent error code written to <code>PlcLog.csv</code> : AABBBBBBDD: %SW142 = AABB hex %SW141 = CCCC hex %SW140 = 00DD hex Where: <ul style="list-style-type: none"> • AA = error level • BB = error context • CCCC = error code • DD = error priority (internal use only) 	S
%SW141	Controller last error code 2		
%SW142	Controller last error code 3		
%SW143	Number of entries in <code>PlcLog.csv</code>	Number of error codes contained in <code>PlcLog.csv</code> .	S
%SW147	SD card operation diagnostic code	If %S90 set to 1, indicates the SD card operation result after saving memory words. The diagnostic codes are: <ul style="list-style-type: none"> • 0: No error • 1: Operation in progress • 10: Eject the SD card • 11: No SD card detected • 12: SD card write protected • 13: The SD card is full • 21: Number of memory words invalid • 22: No memory words to be saved • 30: A line in the CSV file is invalid • 31: A line in the CSV file is too long • 32: Format of the CSV file invalid • 40: Error when creating the CSV file • 50: Internal system error • 51: Error when opening the CSV file 	S
%SW148	Number of persistent variables	<ul style="list-style-type: none"> • If %S90 is set to 0, you can save up to 2000 memory words (%MW50 up to %MW2049). • If %S90 is set to 1, you can save all memory words from %MW0. For more information, refer to <i>Persistent Variables Saved by User Request</i> , page 44.	U
%SW149	Event execution time	Indicates the last execution time in ms of the event task associated with the input %I0.2.	S
%SW150	Event execution time	Indicates the last execution time in ms of the event task associated with the input %I0.3.	S
%SW151	Event execution time	Indicates the last execution time in ms of the event task associated with the input %I0.4.	S
%SW152	Event execution time	Indicates the last execution time in ms of the event task associated with the input %I0.5.	S
%SW153	Event execution time	Indicates the last execution time in ms of the event task associated with the Threshold 0 of <i>HSC0</i> or <i>HSC2</i> .	S
%SW154	Event execution time	Indicates the last execution time in ms of the event task associated with the Threshold 1 of <i>HSC0</i> or <i>HSC2</i> .	S
%SW155	Event execution time	Indicates the last execution time in ms of the event task associated with the Threshold 0 of <i>HSC1</i> or <i>HSC3</i> .	S
%SW156	Event execution time	Indicates the last execution time in ms of the event task associated with the Threshold 1 of <i>HSC1</i> or <i>HSC3</i> .	S
%SW157	Periodic execution time	Indicates the last execution time of the periodic task in ms.	S
%SW158	Periodic average time	Indicates the average execution time in ms of the periodic task (last 5 times).	S
%SW159	Event 0 average time	Indicates the average execution time in ms of the event task associated with the input %I0.2 (last 5 times).	S
%SW160	Event 1 average time	Indicates the average execution time in ms of the event task associated with the input %I0.3 (last 5 times).	S

System Words	Function	Description	Control
%SW161	Event 2 average time	Indicates the average execution time in ms of the event task associated with the input %I0.4 (last 5 times).	S
%SW162	Event 3 average time	Indicates the average execution time in ms of the event task associated with the input %I0.5 (last 5 times).	S
%SW163	Event 4 average time	Indicates the average execution time in ms of the event task associated with the Threshold 0 of HSC0 or HSC2 (last 5 times).	S
%SW164	Event 5 average time	Indicates the average execution time in ms of the event task associated with the Threshold 1 of HSC0 or HSC2 (last 5 times).	S
%SW165	Event 6 average time	Indicates the average execution time in ms of the event task associated with the Threshold 0 of HSC1 or HSC3 (last 5 times).	S
%SW166	Event 7 average time	Indicates the average execution time in ms of the event task associated with the Threshold 1 of HSC1 or HSC3 (last 5 times).	S
%SW167	Status of Modem initialization command	<p>%SW167 indicates the status of the initialization command sent to the modem:</p> <ul style="list-style-type: none"> If the modem does not respond to the initialization command within 10 attempts, its value is FFFF; modem does not respond. If the modem responds "OK" within the 10 attempts, its value is 0; modem is present and has accepted the initialization command. If the modem sends something else within the 10 attempts, its value is 4; incorrect response from the modem, or the modem rejects the initialization command. <p>NOTE: %S105 can be used to re-send the modem initialization command.</p>	S
%SW168	Modbus TCP – Connections in use	<p>Indicates the number of Ethernet Modbus TCP server connections in use.</p> <p>NOTE: If you disconnect the cable, the connection is not closed immediately. Each time the cable is re-connected to the network, it requests a new connection and the number of connections in use indicated by %SW168 increases.</p>	S
%SW170	Frames transmitted – Serial line 1	Indicates the count of frames transmitted by the serial line 1.	S
%SW171	Frames transmitted – Serial line 2	Indicates the count of frames transmitted by the serial line 2.	S
%SW172	Frames transmitted – USB	Indicates the count of frames transmitted by the USB channel.	S
%SW173	Frames transmitted – Modbus TCP	Indicates the count of frames transmitted by Modbus TCP on Ethernet.	S
%SW174	Frames received successfully – Serial line 1	Indicates the count of frames correctly received by the serial line 1.	S
%SW175	Frames received successfully – Serial line 2	Indicates the count of frames correctly received by the serial line 2.	S
%SW176	Frames received successfully – USB	Indicates the count of frames correctly received by the USB channel.	S
%SW177	Frames received successfully – Modbus TCP	Indicates the count of frames correctly received by the Modbus TCP on Ethernet.	S
%SW178	Frames received with an error – Serial line 1	Indicates the count of frames received with an error detected for the serial line 1.	S
%SW179	Frames received with an error – Serial line 2	Indicates the count of frames received with an error detected for the serial line 2.	S
%SW180	Frames received with an error – USB	Indicates the count of frames received with an error detected for the USB channel.	S
%SW181	Frames received with an error – Modbus TCP	Indicates the count of frames received with an error detected for Modbus TCP on Ethernet.	S

System Words	Function	Description	Control
%SW182	Remote Graphic Display connection state	Indicates the connection state of the Remote Graphic Display: <ul style="list-style-type: none"> 0: Display not connected 1: Display application not ready 2: Display application transfer 3: Display application running 4: Display firmware update required 5: Display firmware transfer in progress 	S
%SW183	Remote Graphic Display last error detected	Indicates the last error detected on the Remote Graphic Display: <ul style="list-style-type: none"> 0: No error detected 1: Display application transfer unsuccessful 2: Incompatible version of the display 	S
%SW184	Remote Graphic Display Page Index	Indicates the page index of the displayed page on the Remote Graphic Display. When written, specifies the page index of the page to display on the Remote Graphic Display, if it exists. Otherwise, the value is ignored. A page index is generated by EcoStruxure Machine Expert - Basic when the user creates a new Operator Interface page. The following pages have fixed page index values: <ul style="list-style-type: none"> 112: Setup Menu 113: Controller Information 114: Controller Setup 117: Display Setup 120: Controller State 121: Controller Status 128: Alarm View 	S, U
%SW185	TMH2GDB firmware version xx.yy	Firmware version of the TMH2GDB Remote Graphic Display. For example, %SW185 = 0104 hex means that the firmware version is V1.4.	S
%SW188	Frames transmitted - Modbus Mapping table	Total number of frames transmitted via the Modbus mapping table.	S
%SW189	Frames received - Modbus Mapping table	Total number of frames received without error via the Modbus mapping table.	S
%SW190, %SW191	Class 1 outgoing packets sent	Total number of outgoing packets sent for implicit (Class 1) connections.	S
%SW192, %SW193	Class 1 incoming packets received	Total number of incoming packets received for implicit (Class 1) connections.	S
%SW194, %SW195	Unconnected incoming packets received	Total number of incoming unconnected packets, including packets that would be returned if an error was detected.	S
%SW196, %SW197	Unconnected incoming packets invalid	Total number of incoming unconnected packets that had an invalid format, or targeted an unsupported service, class, instance, attribute, or member.	S
%SW198, %SW199	Incoming packets received for explicit (Class 3) connections	Total number of incoming packets for explicit (Class 3) connections, including packets that would be returned if an error was detected.	S
%SW200, %SW201	Incoming Class 3 packets invalid	Total number of explicit (Class 3) packets that had an invalid format, or targeted an unsupported service, class, instance, attribute, or member.	S
%SW202	Instance input	Instance input configured in EcoStruxure Machine Expert - Basic. Default value: 0	S
%SW203	Input size	Input size configured in EcoStruxure Machine Expert - Basic. Default value: 0	S
%SW204	Instance output	Instance output configured in EcoStruxure Machine Expert - Basic. Default value: 0	S
%SW205	Output size	Output size configured in EcoStruxure Machine Expert - Basic. Default value: 0	S
%SW206	Timeout	Total number of connection timeouts that have occurred in connections. Default value: 0	S, U

System Words	Function	Description	Control
%SW207	Status of the Ethernet/IP class 1 connection	<p>Indicates the status of the EtherNet/IP class 1 connection:</p> <ul style="list-style-type: none"> • 0: At least one connection is idle. • 1: The open connections are in run. • 2: At least one connection has no indication or no communication. <p>NOTE: Status 2 overrides status 0.</p> <p>NOTE: The application must be configured with a functional level (see EcoStruxure Machine Expert - Basic, Operating Guide) of at least Level 3.2 for this word to be supported.</p>	S
%SW210	Status of the IScanner SL1	<p>Contains the status of the Modbus Serial IScanner on Serial Line 1:</p> <ul style="list-style-type: none"> • 0: IScanner is stopped • 1: Initialization request to device being sent by IScanner • 2: IScanner is operational • 3: IScanner is partially operational (some devices are not being scanned) • 4: IScanner is suspended 	S
%SW211	Status of the IScanner SL2	<p>Contains the status of the Modbus Serial IScanner on Serial Line 2:</p> <ul style="list-style-type: none"> • 0: IScanner is stopped • 1: Initialization request being sent by IScanner • 2: IScanner is operational • 3: IScanner is partially operational (some devices are not being scanned) • 4: IScanner is suspended 	S
%SW212	Status of the Modbus TCP IScanner	<p>Contains the status of the Modbus TCP IScanner on Ethernet:</p> <ul style="list-style-type: none"> • 0: IScanner is stopped • 1: Initialization request being sent by IScanner to device • 2: IScanner is operational • 3: IScanner is partially operational (some devices are not being scanned) • 4: IScanner is suspended <p>NOTE: The application must be configured with a functional level (see EcoStruxure Machine Expert - Basic, Operating Guide) of at least Level 6.0 for this system word to be supported.</p>	S
<p>S Controlled by the system</p> <p>U Controlled by the user</p> <p>SIM Applied in the simulator</p>			

M221 Logic Controller Code ID

This table presents the code IDs of the M221 Logic Controller references:

Reference	Code ID
TM221M16R•	0x0780
TM221ME16R•	0x0781
TM221M16T•	0x0782
TM221ME16T•	0x0783
TM221M32TK	0x0784
TM221ME32TK	0x0785
TM221C16R	0x0786
TM221CE16R	0x0787
TM221C16U	0x0796
TM221CE16U	0x0797
TM221C16T	0x0788
TM221CE16T	0x0789
TM221C24R	0x078A
TM221CE24R	0x078B
TM221C24T	0x078C
TM221CE24T	0x078D
TM221C24U	0x0798
TM221CE24U	0x0799
TM221C40R	0x078E
TM221CE40R	0x078F
TM221C40T	0x0790
TM221CE40T	0x0791
TM221C40U	0x079A
TM221CE40U	0x079B

Input Channel Status (%IWS)

Introduction

The following provides information about the properties of input channel status words. A dedicated input channel status word exists for each analog input channel added using an I/O expansion module or TMC2 cartridge.

Displaying Input Channel Status Word Properties

Follow these steps to display the properties of the input channel status words:

Step	Action
1	Select the Tools tab in the left-hand area of the Programming window.
2	Click System objects > Input Status Words . Result: Input channel status word properties is displayed.

Input Channel Status Word Properties

This table describes each property of the input channel status word:

Parameter	Editable	Value	Default Value	Description
Used	No	TRUE/FALSE	FALSE	Indicates whether the input channel status word is being referenced in a program.
Address	No	%IWSx.y or %IWS0.x0y	–	The address of the input channel status word. For I/O expansion modules: <ul style="list-style-type: none"> x is the module number y is the channel number For analog cartridges: <ul style="list-style-type: none"> x is the cartridge number y is the channel number For example, %IWS0.101 is the address of the second channel of the cartridge in the first slot of the logic controller.
Symbol	Yes	–	–	The symbol associated with the input channel status word. Double-click in the Symbol column and type the name of the symbol to associate with the input channel status word. If a symbol already exists, right-click in the Symbol column and choose Search and Replace to find and replace occurrences of the symbol throughout the program and/or program comments.
Comment	Yes	–	–	A comment associated with the input channel status word. Double-click in the Comment column and type an optional comment to associate with the input channel status word.

For More Information

To view the possible values of the input channel status word:

For information on:	refer to...
TM3 expansion modules	TM3 Analog I/O Modules Diagnostics (see Modicon TM3 (EcoStruxure Machine Expert - Basic), Expansion Modules Configuration, Programming Guide)
TM2 expansion modules	TM2 Analog I/O Modules Diagnostics (see Modicon TM2 (SoMachine Basic), Expansion Modules Configuration, Programming Guide)
TMC2 cartridges	TMC2 Analog Cartridge Diagnostics (see Modicon TMC2, Cartridges, Programming Guide)

Output Channel Status (%QWS)

Introduction

The following provides information about the properties of output status words. A dedicated output channel status word exists for each analog output channel added using an I/O expansion module or TMC2 cartridge.

Displaying Output Channel Status Words Properties

Follow these steps to display the properties of the output channel status words:

Step	Action
1	Select the Tools tab in the left-hand area of the Programming window.
2	Click System objects > Output Status Words . Result: Output channel status word properties are displayed in the properties window.

Output Channel Status Word Properties

This table describes each property of the output channel status word:

Parameter	Editable	Value	Default Value	Description
Used	No	TRUE/FALSE	FALSE	Indicates whether the output channel status word is being referenced in a program.
Address	No	%QWSx.yor %QWS0.x0y	–	The address of the output channel status word. For I/O expansion modules: <ul style="list-style-type: none"> • x is the module number • y is the channel number For cartridges: <ul style="list-style-type: none"> • x is the cartridge number • y is the channel number For example, %QWS3.0 is the address of the first output channel in the third I/O expansion module connected to the logic controller.
Symbol	Yes	–	–	The symbol associated with the output channel status word. Double-click in the Symbol column and type the name of the symbol to associate with the output channel status word. If a symbol already exists, right-click in the Symbol column and choose Search and Replace to find and replace occurrences of the symbol throughout the program and/or program comments.
Comment	Yes	–	–	A comment associated with the output channel status word. Double-click in the Comment column and type an optional comment to associate with the output channel status word.

For More Information

To view the possible values of the output channel status word:

For information on:	refer to...
TM3 expansion modules	TM3 Analog I/O Modules Diagnostics (see Modicon TM3 (EcoStruxure Machine Expert - Basic), Expansion Modules Configuration, Programming Guide)
TM2 expansion modules	TM2 Analog I/O Modules Diagnostics (see Modicon TM2 (SoMachine Basic), Expansion Modules Configuration, Programming Guide)
TMC2 cartridges	TMC2 Analog Cartridge Diagnostics (see Modicon TMC2, Cartridges, Programming Guide)

Glossary

A

analog input:

Converts received voltage or current levels into numerical values. You can store and process these values within the logic controller.

analog output:

Converts numerical values within the logic controller and sends out proportional voltage or current levels.

B

BOOTP:

(bootstrap protocol) A UDP network protocol that can be used by a network client to automatically obtain an IP address (and possibly other data) from a server. The client identifies itself to the server using the client MAC address. The server, which maintains a pre-configured table of client device MAC addresses and associated IP addresses, sends the client its pre-configured IP address. BOOTP was originally used as a method that enabled diskless hosts to be remotely booted over a network. The BOOTP process assigns an infinite lease of an IP address. The BOOTP service utilizes UDP ports 67 and 68.

C

CFC:

(continuous function chart) A graphical programming language (an extension of the IEC 61131-3 standard) based on the function block diagram language that works like a flowchart. However, no networks are used and free positioning of graphic elements is possible, which allows feedback loops. For each block, the inputs are on the left and the outputs on the right. You can link the block outputs to the inputs of other blocks to create complex expressions.

configuration:

The arrangement and interconnection of hardware components within a system and the hardware and software parameters that determine the operating characteristics of the system.

continuous function chart language:

A graphical programming language (an extension of the IEC61131-3 standard) based on the function block diagram language that works like a flowchart. However, no networks are used and free positioning of graphic elements is possible, which allows feedback loops. For each block, the inputs are on the left and the outputs on the right. You can link the block outputs to inputs of other blocks to create complex expressions.

D

DHCP:

(dynamic host configuration protocol) An advanced extension of BOOTP. DHCP is more advanced, but both DHCP and BOOTP are common. (DHCP can handle BOOTP client requests.)

digital I/O:

(digital input/output) An individual circuit connection at the electronic module that corresponds directly to a data table bit. The data table bit holds the value of the signal at the I/O circuit. It gives the control logic digital access to I/O values.

E

EDS:

(*electronic data sheet*) A file for fieldbus device description that contains, for example, the properties of a device such as parameters and settings.

EtherNet/IP Adapter:

An EtherNet/IP Adapter, sometimes also called a server, is an end-device in an EtherNet/IP network. I/O blocks and drives can be EtherNet/IP Adapter devices.

EtherNet/IP:

(*Ethernet industrial protocol*) An open communications protocol for manufacturing automation solutions in industrial systems. EtherNet/IP is in a family of networks that implement the common industrial protocol at its upper layers. The supporting organization (ODVA) specifies EtherNet/IP to accomplish global adaptability and media independence.

F

FBD:

(*function block diagram*) One of 5 languages for logic or control supported by the standard IEC 61131-3 for control systems. Function block diagram is a graphically oriented programming language. It works with a list of networks, where each network contains a graphical structure of boxes and connection lines, which represents either a logical or arithmetic expression, the call of a function block, a jump, or a return instruction.

FreqGen:

(*frequency generator*) A function that generates a square wave signal with programmable frequency.

G

GRAFSET:

The functioning of a sequential operation in a structured and graphic form.

This is an analytical method that divides any sequential control system into a series of steps, with which actions, transitions, and conditions are associated.

H

HMI:

(*human machine interface*) An operator interface (usually graphical) for human control over industrial equipment.

HSC:

(*high-speed counter*) A function that counts pulses on the controller or on expansion module inputs.

I

IEC 61131-3:

Part 3 of a 3-part IEC standard for industrial automation equipment. IEC 61131-3 is concerned with controller programming languages and defines 2 graphical and 2 textual programming language standards. The graphical programming languages are ladder diagram and function block diagram. The textual programming languages include structured text and instruction list.

IL:

(instruction list) A program written in the language that is composed of a series of text-based instructions executed sequentially by the controller. Each instruction includes a line number, an instruction code, and an operand (refer to IEC 61131-3).

Input Assembly:

Assemblies are blocks of data exchanged between network devices and the logic controller. An Input Assembly generally contains status information from a network device read by the controller.

instruction list language:

A program written in the instruction list language that is composed of a series of text-based instructions executed sequentially by the controller. Each instruction includes a line number, an instruction code, and an operand (see IEC 61131-3).

L**ladder diagram language:**

A graphical representation of the instructions of a controller program with symbols for contacts, coils, and blocks in a series of rungs executed sequentially by a controller (see IEC 61131-3).

LAN:

(local area network) A short-distance communications network that is implemented in a home, office, or institutional environment.

LD:

(ladder diagram) A graphical representation of the instructions of a controller program with symbols for contacts, coils, and blocks in a series of rungs executed sequentially by a controller (refer to IEC 61131-3).

LSB:

(least significant bit/byte) The part of a number, address, or field that is written as the right-most single value in conventional hexadecimal or binary notation.

M**master task:**

A processor task that is run through its programming software. The master task has 2 sections:

- **IN:** Inputs are copied to the IN section before execution of the master task.
- **OUT:** Outputs are copied to the OUT section after execution of the master task.

Modbus:

The protocol that allows communications between many devices connected to the same network.

MSB:

(most significant bit/byte) The part of a number, address, or field that is written as the left-most single value in conventional hexadecimal or binary notation.

N**N/C:**

(normally closed) A contact pair that closes when the actuator is de-energized (no power is applied) and opens when the actuator is energized (power is applied).

N/O:

(normally open) A contact pair that opens when the actuator is de-energized (no power is applied) and closes when the actuator is energized (power is applied).

O**Output Assembly:**

Assemblies are blocks of data exchanged between network devices and the logic controller. An Output Assembly generally contains command sent by the controller to network devices.

P**periodic execution:**

The task is executed either cyclically or periodically. In periodic mode, you determine a specific time (period) in which the task is executed. If it is executed under this time, a waiting time is generated before the next cycle. If it is executed over this time, a control system indicates the overrun. If the overrun is too high, the controller is stopped.

periodic task:

The periodic task is a periodic, high-priority task of short duration that runs on a logic controller through its programming software. The short duration of the periodic task prevents it from interfering with the execution of slower, lower priority tasks. A periodic task is useful when fast periodic changes in digital inputs need to be monitored.

PID:

(proportional, integral, derivative) A generic control loop feedback mechanism (controller) widely used in industrial control systems.

post configuration:

(post configuration) An option that allows to modify some parameters of the application without changing the application. Post configuration parameters are defined in a file that is stored in the controller. They are overloading the configuration parameters of the application.

protocol:

A convention or standard definition that controls or enables the connection, communication, and data transfer between 2 computing system and devices.

PTO:

(pulse train outputs) A fast output that oscillates between off and on in a fixed 50-50 duty cycle, producing a square wave form. PTO is especially well suited for applications such as stepper motors, frequency converters, and servo motor control, among others.

PWM:

(pulse width modulation) A fast output that oscillates between off and on in an adjustable duty cycle, producing a rectangular wave form (though you can adjust it to produce a square wave).

R**RTC:**

(real-time clock) A battery-backed time-of-day and calendar clock that operates continuously, even when the controller is not powered for the life of the battery.

S

security parameters:

A set of configuration parameters used to enable or disable specific protocols and features relating to the cybersecurity of an application.

SFC:

(*sequential function chart*) A language that is composed of steps with associated actions, transitions with associated logic condition, and directed links between steps and transitions. (The SFC standard is defined in IEC 848. It is IEC 61131-3 compliant.)

SMS:

(*short message service*) A standard communication service for telephones (or other devices) that send short text messages over the mobile communications system.

ST:

(*structured text*) A language that includes complex statements and nested instructions (such as iteration loops, conditional executions, or functions). ST is compliant with IEC 61131-3.

Index

A	
active I/O bus error handling.....	86
adapter	
<i>EtherNet/IP</i>	109
Altivar devices	
adding to Modbus Serial IOScanner	128
analog inputs	67
configuration.....	68
introduction	67
properties.....	154
analog outputs	
properties.....	156
application download	42
B	
backup controller memory.....	151
boot controller	41
C	
%C.....	29
cartridges	
configuration.....	94
TMC2.....	94
channel assistant	
Modbus Serial IOScanner.....	132
Modbus TCP IOScanner.....	106
channels	
Modbus Serial IOScanner.....	133
Modbus TCP IOScanner.....	108
Cold Start	43
configuration	
building a configuration.....	53
configuration introduction.....	53
Frequency Meter.....	75
HSC.....	72
Modbus Serial IOScanner.....	128
controller	
configuration.....	53, 61
configuration features.....	25
controller state	38–39
BOOTING	40
EMPTY	40
HALTED.....	41
POWERLESS.....	41
RUNNING	40
STOPPED.....	40
cyber security.....	97
D	
devices	
adding to Modbus Serial IOScanner	128
digital inputs.....	63
configuration.....	63
introduction	63
of IOScanner, properties.....	161
properties	153
digital outputs.....	66
configuration.....	66
configuration parameters.....	66
configuring fallback values for	66
introduction	66
of IOScanner, properties.....	162
properties	154
downloading applications.....	41
%DR	29
E	
EDS file, Modbus TCP	111
embedded communication	
configuration.....	95
embedded input/output	
configuration.....	63
Ethernet	
configuration.....	97
cyber security	97
device and channel diagnostic bits	166
introduction	95
Ethernet services	96
EtherNet/IP	
adapter	109
configuration.....	109
executive loader.....	62
expansion modules	
configuration.....	94
TM2	94
TM3	94
F	
fallback	
values, configuring	66
fallback behavior configuration	46
fallback execution.....	47
fallback management	46
fallback values	47, 157, 159
%FC.....	29
features	
key features.....	16, 21
firmware	62
updating with executive loader	62
updating with SD card	141
firmware updates.....	41
%FREQGEN.....	29
frequency generator	
configuration.....	84
Frequency Meter	
configuration.....	75
G	
generic slave device	128
H	
HALTED state	43
hardware initialization values.....	46
high speed counters	69
configuration.....	70
introduction	69
%HSC	29
configuration.....	72
I	
%I	29, 153
%IN.....	161
Init command	123

initialization request assistant		configuring client mode.....	103
Modbus Serial IONScanner.....	130	configuring Modbus mapping	101
Modbus TCP IONScanner.....	104	device and channel diagnostic bits	166
initialization values	46	initialization request assistant.....	104
Initialize controller	42	%MSG	29
Input assembly		%MW	29
properties.....	157		
input channel status (%IWS)).....	189	N	
input registers		network diagnostic codes (%IWNS).....	166
properties.....	159	network objects	102, 157
Input registers (IONScanner)		%IN	161
properties.....	163	Input assembly (EtherNet/IP).....	157
I/O assignment.....	69	Input registers (IONScanner).....	163
I/O bus		Input registers (Modbus TCP)	159
configuration.....	86	Output assembly (EtherNet/IP)	158
I/O bus error handling		Output registers (IONScanner).....	164
active	86–87	Output registers (Modbus TCP).....	160
I/O configuration general information		%QN.....	162
general practices	86		
I/O expansion bus		O	
restarting.....	88	objects	
I/O objects		addressing	29
analog inputs.....	154	addressing examples	29
Analog Outputs.....	156	definition of.....	25
digital inputs	153	introduction	26
digital outputs	154	maximum number allowed	31
IONScanner, Modbus Serial	128	network	157
%IW	29, 154	object types	26
%IWE.....	29, 158	Output assembly (EtherNet/IP)	
%IWM	29, 160	properties.....	158
%IWM/%QWM.....	102	output behavior	45, 47
%IWN.....	163	output channel status (%QWS).....	191
%IWNS (IONScanner network diagnostic codes)	166	output forcing	47
%IWS (input channel status)	189	output rearming.....	48
		output registers	
K		properties.....	160
%KD	29	Output registers (IONScanner)	
%KF.....	29	properties.....	164
%KW.....	29		
		P	
M		%PARAM	29
%M	29	passive I/O bus error handling	87
Machine.cfg (post configuration file).....	50	persistent variables	44
maintain values fallback mode.....	157, 159	%PLS.....	29
mapping table, Modbus TCP	102, 136, 159–160	Post Conf	
%MD	29	Presentation	49
memory objects		post configuration	
backing up and restoring	151	file management	50
%MF	29	Post Configuration	
Modbus mapping table	101–102	Presentation	49
Modbus Serial IONScanner		programming languages	
adding devices on	128	IL, LD	21
channel assistant.....	132	IL, LD, Grafcet	16
configuring	128	pulse generators	77
configuring channels	133	configuration.....	77
device and channel diagnostic bits	166	FREQGEN configuration	84
initialization request assistant.....	130	introduction	77
Modbus TCP		PLS configuration	79
configuring client mode.....	103	PTO configuration	82
configuring Modbus mapping	101	PWM configuration.....	81
EDS file.....	111	%PWM.....	29
mapping table.....	136, 159		
remote devices	103		
Modbus TCP IONScanner			
channel assistant.....	106		
configuring channels	108		

Q		U	
%Q	29, 154	unit ID	102
%QN	162	updating firmware.....	62, 141
%QW	29, 156	uploading applications	41
%QWE	29, 157		
%QWM	29, 159	V	
%QWN	164	%VAR	29
%QWS (Output channel status).....	191		
R		W	
%R.....	29	Warm start.....	44
rearming outputs	48		
remote devices			
adding to Modbus TCP	103		
restarting I/O expansion bus.....	88		
restore controller memory	151		
RUN Controller.....	42		
Run/Stop	64		
configuring digital input as	64		
S			
%S.....	29		
%S (system bits)	167		
%S93	44		
%S94	45		
%SBR	29		
%SC	29		
SD card	141		
application management	145		
cloning	140		
post configuration management	146		
updating firmware	141		
serial line	122, 127		
configuration.....	123		
configuring Modbus Serial IOScanner.....	128		
configuring to use %SEND_RECV_SMS	123		
introduction	122		
software initialization values	46		
STOP Controller.....	43		
supported devices	94		
%SW	29		
%SW (system words)	174		
%SW118	58		
%SW119	58		
%SW120	58		
%SW148	44–45		
%SW6	39, 41		
system bits			
%S106	87		
%S107	88		
%S93	44		
%S94	45		
system words			
%SW118	58		
%SW119	58		
%SW120	58		
%SW148	44–45		
T			
%TM	29		
TM3 expansion modules			
updating firmware	141		

Schneider Electric
35 rue Joseph Monier
92500 Rueil Malmaison
France

+ 33 (0) 1 41 29 70 00

www.se.com

As standards, specifications, and design change from time to time,
please ask for confirmation of the information given in this publication.

© 2024 Schneider Electric. All rights reserved.

EIO0000003297.03

Modicon M221

Logic Controller

Advanced Functions Library Guide

EIO0000003305.02
11/2022

Legal Information

The Schneider Electric brand and any trademarks of Schneider Electric SE and its subsidiaries referred to in this guide are the property of Schneider Electric SE or its subsidiaries. All other brands may be trademarks of their respective owners.

This guide and its content are protected under applicable copyright laws and furnished for informational use only. No part of this guide may be reproduced or transmitted in any form or by any means (electronic, mechanical, photocopying, recording, or otherwise), for any purpose, without the prior written permission of Schneider Electric.

Schneider Electric does not grant any right or license for commercial use of the guide or its content, except for a non-exclusive and personal license to consult it on an "as is" basis. Schneider Electric products and equipment should be installed, operated, serviced, and maintained only by qualified personnel.

As standards, specifications, and designs change from time to time, information contained in this guide may be subject to change without notice.

To the extent permitted by applicable law, no responsibility or liability is assumed by Schneider Electric and its subsidiaries for any errors or omissions in the informational content of this material or consequences arising out of or resulting from the use of the information contained herein.

As part of a group of responsible, inclusive companies, we are updating our communications that contain non-inclusive terminology. Until we complete this process, however, our content may still contain standardized industry terms that may be deemed inappropriate by our customers.

© 2022 – Schneider Electric. All rights reserved.

Table of Contents

Safety Information	7
Before You Begin	7
Start-up and Test	8
Operation and Adjustments	9
About the Book	10
Introduction to Advanced Functions	15
Introduction	16
Expert I/O	17
Embedded Expert I/O Mapping	19
General Information on Function Block Management	21
Advanced Expert Input Functions	22
Fast Counter (%FC)	23
Description	23
Configuration	24
Programming Example	26
High Speed Counter (%HSC)	28
Description	28
High Speed Counter in Counting Modes	32
High Speed Counter in Frequency Meter Mode	38
Advanced Expert Output Functions	40
Pulse (%PLS)	41
Description	41
Function Block Configuration	42
Programming Example	46
Pulse Width Modulation (%PWM)	47
Description	47
Function Block Configuration	48
Programming Example	51
Drive (%DRV)	52
Description	52
Drive and Logic Controller States	54
Adding a Drive Function Block	56
Function Block Configuration	57
MC_Power_ATV: Enable/Disable Power Stage	57
MC_Jog_ATV: Start Jog Mode	59
MC_MoveVel_ATV: Move at Specified Velocity	62
MC_Stop_ATV: Stop Movement	64
MC_ReadStatus_ATV: Read Device Status	66
MC_ReadMotionState_ATV: Read Motion State	68
MC_Reset_ATV: Acknowledge and Reset Error	70
Error Codes	72
Pulse Train Output (%PTO)	75
Description	75
Pulse Train Output (PTO)	75
Pulse Output Modes	77
Acceleration / Deceleration Ramp	78
Probe Event	80
Backlash Compensation	82

Positioning Limits	83
Configuration	85
PTO Configuration	85
Motion Task Table	85
Programming	92
Adding / Removing a Function Block	92
PTO Function Blocks	93
Home Modes	94
Homing Modes	94
Position Setting	96
Long Reference	96
Short Reference No Reversal	97
Short Reference Reversal	98
Home Offset	100
Data Parameters	100
Function Block Object Codes	100
Operation Modes	105
Motion State Diagram	105
Buffer Mode	106
Motion Function Blocks	108
<i>MC_MotionTask_PTO</i> Function Block	108
<i>MC_Power_PTO</i> Function Block	111
<i>MC_MoveVel_PTO</i> Function Block	114
<i>MC_MoveRel_PTO</i> Function Block	117
<i>MC_MoveAbs_PTO</i> Function Block	120
<i>MC_Home_PTO</i> Function Block	123
<i>MC_SetPos_PTO</i> Function Block	125
<i>MC_Stop_PTO</i> Function Block	126
<i>MC_Halt_PTO</i> Function Block	128
Administrative Function Blocks	130
<i>MC_ReadActVel_PTO</i> Function Block	130
<i>MC_ReadActPos_PTO</i> Function Block	132
<i>MC_ReadSts_PTO</i> Function Block	133
<i>MC_ReadMotionState_PTO</i> Function Block	135
<i>MC_ReadAxisError_PTO</i> Function Block	136
<i>MC_Reset_PTO</i> Function Block	138
<i>MC_TouchProbe_PTO</i> Function Block	139
<i>MC_AbortTrigger_PTO</i> Function Block	141
<i>MC_ReadPar_PTO</i> Function Block	142
<i>MC_WritePar_PTO</i> Function Block	143
Frequency Generator (%FREQGEN)	145
Description	145
Configuration	146
Advanced Software Functions	148
PID Function	149
PID Operating Modes	149
PID Operating Modes	149
PID Auto-Tuning Configuration	150
PID Auto-Tuning Configuration	150
PID Standard Configuration	153
PID Word Address Configuration	153

PID Tuning with Auto-Tuning (AT).....	155
Manual Mode.....	158
Determining the Sampling Period (Ts).....	160
PID Assistant.....	162
Access the PID Assistant.....	162
General Tab.....	163
Input Tab.....	164
PID Tab.....	165
AT Tab.....	167
Output Tab.....	168
PID Programming.....	170
Description.....	170
Programming and Configuring.....	171
PID States and Detected Error Codes.....	172
Appendices.....	174
PID Parameters.....	175
Role and Influence of PID Parameters.....	175
PID Parameter Adjustment Method.....	176
Glossary.....	179
Index.....	181

Safety Information

Important Information

Read these instructions carefully, and look at the equipment to become familiar with the device before trying to install, operate, service, or maintain it. The following special messages may appear throughout this documentation or on the equipment to warn of potential hazards or to call attention to information that clarifies or simplifies a procedure.



The addition of this symbol to a “Danger” or “Warning” safety label indicates that an electrical hazard exists which will result in personal injury if the instructions are not followed.



This is the safety alert symbol. It is used to alert you to potential personal injury hazards. Obey all safety messages that follow this symbol to avoid possible injury or death.

⚠ DANGER
DANGER indicates a hazardous situation which, if not avoided, will result in death or serious injury.

⚠ WARNING
WARNING indicates a hazardous situation which, if not avoided, could result in death or serious injury.

⚠ CAUTION
CAUTION indicates a hazardous situation which, if not avoided, could result in minor or moderate injury.

NOTICE
NOTICE is used to address practices not related to physical injury.

Please Note

Electrical equipment should be installed, operated, serviced, and maintained only by qualified personnel. No responsibility is assumed by Schneider Electric for any consequences arising out of the use of this material.

A qualified person is one who has skills and knowledge related to the construction and operation of electrical equipment and its installation, and has received safety training to recognize and avoid the hazards involved.

Before You Begin

Do not use this product on machinery lacking effective point-of-operation guarding. Lack of effective point-of-operation guarding on a machine can result in serious injury to the operator of that machine.

⚠ WARNING**UNGUARDED EQUIPMENT**

- Do not use this software and related automation equipment on equipment which does not have point-of-operation protection.
- Do not reach into machinery during operation.

Failure to follow these instructions can result in death, serious injury, or equipment damage.

This automation equipment and related software is used to control a variety of industrial processes. The type or model of automation equipment suitable for each application will vary depending on factors such as the control function required, degree of protection required, production methods, unusual conditions, government regulations, etc. In some applications, more than one processor may be required, as when backup redundancy is needed.

Only you, the user, machine builder or system integrator can be aware of all the conditions and factors present during setup, operation, and maintenance of the machine and, therefore, can determine the automation equipment and the related safeties and interlocks which can be properly used. When selecting automation and control equipment and related software for a particular application, you should refer to the applicable local and national standards and regulations. The National Safety Council's Accident Prevention Manual (nationally recognized in the United States of America) also provides much useful information.

In some applications, such as packaging machinery, additional operator protection such as point-of-operation guarding must be provided. This is necessary if the operator's hands and other parts of the body are free to enter the pinch points or other hazardous areas and serious injury can occur. Software products alone cannot protect an operator from injury. For this reason the software cannot be substituted for or take the place of point-of-operation protection.

Ensure that appropriate safeties and mechanical/electrical interlocks related to point-of-operation protection have been installed and are operational before placing the equipment into service. All interlocks and safeties related to point-of-operation protection must be coordinated with the related automation equipment and software programming.

NOTE: Coordination of safeties and mechanical/electrical interlocks for point-of-operation protection is outside the scope of the Function Block Library, System User Guide, or other implementation referenced in this documentation.

Start-up and Test

Before using electrical control and automation equipment for regular operation after installation, the system should be given a start-up test by qualified personnel to verify correct operation of the equipment. It is important that arrangements for such a check are made and that enough time is allowed to perform complete and satisfactory testing.

⚠ WARNING**EQUIPMENT OPERATION HAZARD**

- Verify that all installation and set up procedures have been completed.
- Before operational tests are performed, remove all blocks or other temporary holding means used for shipment from all component devices.
- Remove tools, meters, and debris from equipment.

Failure to follow these instructions can result in death, serious injury, or equipment damage.

Follow all start-up tests recommended in the equipment documentation. Store all equipment documentation for future references.

Software testing must be done in both simulated and real environments.

Verify that the completed system is free from all short circuits and temporary grounds that are not installed according to local regulations (according to the National Electrical Code in the U.S.A, for instance). If high-potential voltage testing is necessary, follow recommendations in equipment documentation to prevent accidental equipment damage.

Before energizing equipment:

- Remove tools, meters, and debris from equipment.
- Close the equipment enclosure door.
- Remove all temporary grounds from incoming power lines.
- Perform all start-up tests recommended by the manufacturer.

Operation and Adjustments

The following precautions are from the NEMA Standards Publication ICS 7.1-1995:

(In case of divergence or contradiction between any translation and the English original, the original text in the English language will prevail.)

- Regardless of the care exercised in the design and manufacture of equipment or in the selection and ratings of components, there are hazards that can be encountered if such equipment is improperly operated.
- It is sometimes possible to misadjust the equipment and thus produce unsatisfactory or unsafe operation. Always use the manufacturer's instructions as a guide for functional adjustments. Personnel who have access to these adjustments should be familiar with the equipment manufacturer's instructions and the machinery used with the electrical equipment.
- Only those operational adjustments required by the operator should be accessible to the operator. Access to other controls should be restricted to prevent unauthorized changes in operating characteristics.

About the Book

Document Scope

This document provides descriptions of the EcoStruxure Machine Expert - Basic advanced functions and their relation to the M221 Logic Controller expert I/O and PID support. Here you can find descriptions of the functionalities, characteristics and performances of the M221 Logic Controller advanced functions.

Validity Note

The information in this manual is applicable **only** for EcoStruxure Machine Expert - Basic products.

This document has been updated for the release of EcoStruxure™ Machine Expert - Basic V1.2 SP1 Patch 1.

The technical characteristics of the devices described in the present document also appear online. To access the information online, go to the Schneider Electric home page www.se.com/ww/en/download/.

The characteristics that are described in the present document should be the same as those characteristics that appear online. In line with our policy of constant improvement, we may revise content over time to improve clarity and accuracy. If you see a difference between the document and online information, use the online information as your reference.

Related Documents

Title of Documentation	Reference Number
EcoStruxure Machine Expert - Basic Operating Guide	EIO0000003281 (ENG) EIO0000003282 (FRA) EIO0000003283 (GER) EIO0000003284 (SPA) EIO0000003285 (ITA) EIO0000003286 (CHS) EIO0000003287 (POR) EIO0000003288 (TUR)
EcoStruxure Machine Expert - Basic Generic Functions - Library Guide	EIO0000003289 (ENG) EIO0000003290 (FRA) EIO0000003291 (GER) EIO0000003292 (SPA) EIO0000003293 (ITA) EIO0000003294 (CHS) EIO0000003295 (POR) EIO0000003296 (TUR)
Modicon M221 Logic Controller - Programming Guide	EIO0000003297 (ENG) EIO0000003298 (FRE) EIO0000003299 (GER) EIO0000003300 (SPA) EIO0000003301 (ITA) EIO0000003302 (CHS) EIO0000003304 (TUR) EIO0000003303 (POR)
Modicon M221 Logic Controller - Hardware Guide	EIO0000003313 (ENG) EIO0000003314 (FRA) EIO0000003315 (GER) EIO0000003316 (SPA) EIO0000003317 (ITA) EIO0000003318 (CHS) EIO0000003319 (POR) EIO0000003320 (TUR)

Product Related Information

⚠ WARNING

LOSS OF CONTROL

- The designer of any control scheme must consider the potential failure modes of control paths and, for certain critical control functions, provide a means to achieve a safe state during and after a path failure. Examples of critical control functions are emergency stop and overtravel stop, power outage and restart.
- Separate or redundant control paths must be provided for critical control functions.
- System control paths may include communication links. Consideration must be given to the implications of unanticipated transmission delays or failures of the link.
- Observe all accident prevention regulations and local safety guidelines.¹
- Each implementation of this equipment must be individually and thoroughly tested for proper operation before being placed into service.

Failure to follow these instructions can result in death, serious injury, or equipment damage.

¹ For additional information, refer to NEMA ICS 1.1 (latest edition), "Safety Guidelines for the Application, Installation, and Maintenance of Solid State Control" and to NEMA ICS 7.1 (latest edition), "Safety Standards for Construction and Guide for Selection, Installation and Operation of Adjustable-Speed Drive Systems" or their equivalent governing your particular location.

⚠ WARNING

UNINTENDED EQUIPMENT OPERATION

- Only use software approved by Schneider Electric for use with this equipment.
- Update your application program every time you change the physical hardware configuration.

Failure to follow these instructions can result in death, serious injury, or equipment damage.

Terminology Derived from Standards

The technical terms, terminology, symbols and the corresponding descriptions in this manual, or that appear in or on the products themselves, are generally derived from the terms or definitions of international standards.

In the area of functional safety systems, drives and general automation, this may include, but is not limited to, terms such as *safety*, *safety function*, *safe state*, *fault*, *fault reset*, *malfunction*, *failure*, *error*, *error message*, *dangerous*, etc.

Among others, these standards include:

Standard	Description
EN 61131-2:2007	Programmable controllers, part 2: Equipment requirements and tests.
ISO 13849-1:2008	Safety of machinery: Safety related parts of control systems. General principles for design.
EN 61496-1:2013	Safety of machinery: Electro-sensitive protective equipment. Part 1: General requirements and tests.
ISO 12100:2010	Safety of machinery - General principles for design - Risk assessment and risk reduction
EN 60204-1:2006	Safety of machinery - Electrical equipment of machines - Part 1: General requirements
EN 1088:2008 ISO 14119:2013	Safety of machinery - Interlocking devices associated with guards - Principles for design and selection
ISO 13850:2006	Safety of machinery - Emergency stop - Principles for design
EN/IEC 62061:2005	Safety of machinery - Functional safety of safety-related electrical, electronic, and electronic programmable control systems
IEC 61508-1:2010	Functional safety of electrical/electronic/programmable electronic safety-related systems: General requirements.
IEC 61508-2:2010	Functional safety of electrical/electronic/programmable electronic safety-related systems: Requirements for electrical/electronic/programmable electronic safety-related systems.
IEC 61508-3:2010	Functional safety of electrical/electronic/programmable electronic safety-related systems: Software requirements.
IEC 61784-3:2008	Digital data communication for measurement and control: Functional safety field buses.
2006/42/EC	Machinery Directive
2014/30/EU	Electromagnetic Compatibility Directive
2014/35/EU	Low Voltage Directive

In addition, terms used in the present document may tangentially be used as they are derived from other standards such as:

Standard	Description
IEC 60034 series	Rotating electrical machines
IEC 61800 series	Adjustable speed electrical power drive systems
IEC 61158 series	Digital data communications for measurement and control – Fieldbus for use in industrial control systems

Finally, the term *zone of operation* may be used in conjunction with the description of specific hazards, and is defined as it is for a *hazard zone* or *danger zone* in the *Machinery Directive (2006/42/EC)* and *ISO 12100:2010*.

NOTE: The aforementioned standards may or may not apply to the specific products cited in the present documentation. For more information concerning the individual standards applicable to the products described herein, see the characteristics tables for those product references.

Introduction to Advanced Functions

What's in This Part

Introduction.....	16
-------------------	----

Overview

This part provides an overview description, available modes, functionality and performances of the different advanced functions.

Introduction

What's in This Chapter

Expert I/O	17
Embedded Expert I/O Mapping	19
General Information on Function Block Management	21

Overview

This document provides descriptions of the EcoStruxure Machine Expert - Basic advanced functions and their relation to the M221 expert I/O and PID support. Here you can find descriptions of the functionalities, characteristics and performances of the Fast Counter (%FC), High Speed Counter (%HSC), Pulse (%PLS), Pulse Width Modulation (%PWM), and Pulse Train Output (%PTO) inputs and outputs. In addition, you can find a complete description of the PID advanced software functionality. For information about the user-defined functions and the user-defined function blocks, refer to User-Defined Functions (see EcoStruxure Machine Expert - Basic, Operating Guide) and User-Defined Function Blocks (see EcoStruxure Machine Expert - Basic, Operating Guide).

The functions provide simple yet powerful solutions for your application. However, the use and application of the information contained herein require expertise in the design and programming of automated control systems.

Only you, the user, machine builder or integrator, can be aware of all the conditions and factors present during installation and setup, operation, and maintenance of the machine or related processes, and can therefore determine the automation and associated equipment and the related safeties and interlocks which can be effectively and properly used. When selecting automation and control equipment, and any other related equipment or software, for a particular application, you must also consider any applicable local, regional or national standards and/or regulations.

▲ WARNING

REGULATORY INCOMPATIBILITY

Ensure that all equipment applied and systems designed comply with all applicable local, regional, and national regulations and standards.

Failure to follow these instructions can result in death, serious injury, or equipment damage.

The functionality provided by the EcoStruxure Machine Expert - Basic advanced functions for the M221 controllers was conceived and designed assuming that you incorporate the necessary safety hardware into your application architecture, such as, but not limited to, appropriate limit switches and emergency stop hardware and controlling circuitry. It is implicitly assumed that functional safety measures are present in your machine design to prevent undesirable machine behavior such as over-travel or other forms of uncontrolled movement. Further, it is assumed that you have performed a functional safety analysis and risk assessment appropriate to your machine or process.

▲ WARNING

UNINTENDED EQUIPMENT OPERATION

Ensure that a risk assessment is conducted and respected according to EN/ISO 12100 during the design of your machine.

Failure to follow these instructions can result in death, serious injury, or equipment damage.

Expert I/O

Introduction

The M221 logic controller provides:

- Four fast inputs (%I0.0, %I0.1, %I0.6 and %I0.7)
- Two fast outputs on controller references that contain transistor outputs (%Q0.0 and %Q0.1)
- Four fast outputs on controller references TM221C40U and TM221CE40U (%Q0.0, %Q0.1, %Q0.2, and %Q0.3)

NOTE: No fast output functions are supported on controller references that contain relay outputs.

The M221 logic controller supports the following expert I/O functions (depending on the reference):

Functions		Description
Counters	Fast Counter, page 23	The FC function can execute fast counts of pulses from sensors, switches, and so on.
	High Speed Counter, page 28	The HSC function can execute fast counts of pulses from sensors, switches, and so on, that are connected to the fast inputs.
Pulse Generators	Pulse, page 41	The PLS function generates a square wave pulse signal on dedicated output channels.
	Pulse Width Modulation, page 47	The PWM function generates a modulated wave signal on dedicated output channels with a variable duty cycle.
	Pulse Train Output, page 75	The PTO function generates a pulse train output to control a linear single-axis stepper or servo drive in open loop mode.
	Frequency Generator, page 145	The FREQGEN function generates a square wave signal on a dedicated output channel with programmable frequency and duty cycle of 50%.

NOTE:

- When an input is used as Run/Stop, it cannot be used by an expert function.
- When an output is used as Alarm, it cannot be used by an expert function.

For more details, refer to Embedded Input/Output Configuration (see Modicon M221, Logic Controller, Programming Guide).

Configuring an Expert Input Function

To configure an expert input function, proceed as follows:

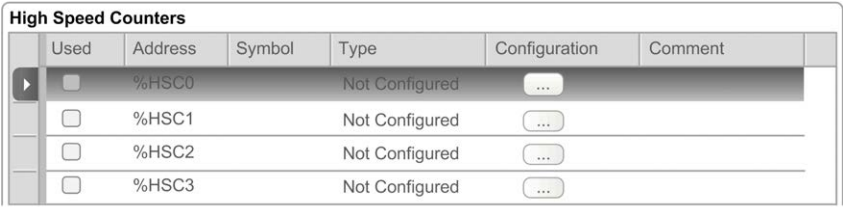
Step	Description																														
1	<p>Click the High Speed Counters node in the hardware tree. Result: The High Speed Counters list is displayed:</p>  <table border="1"> <thead> <tr> <th>Used</th> <th>Address</th> <th>Symbol</th> <th>Type</th> <th>Configuration</th> <th>Comment</th> </tr> </thead> <tbody> <tr> <td><input type="checkbox"/></td> <td>%HSC0</td> <td></td> <td>Not Configured</td> <td>...</td> <td></td> </tr> <tr> <td><input type="checkbox"/></td> <td>%HSC1</td> <td></td> <td>Not Configured</td> <td>...</td> <td></td> </tr> <tr> <td><input type="checkbox"/></td> <td>%HSC2</td> <td></td> <td>Not Configured</td> <td>...</td> <td></td> </tr> <tr> <td><input type="checkbox"/></td> <td>%HSC3</td> <td></td> <td>Not Configured</td> <td>...</td> <td></td> </tr> </tbody> </table>	Used	Address	Symbol	Type	Configuration	Comment	<input type="checkbox"/>	%HSC0		Not Configured	...		<input type="checkbox"/>	%HSC1		Not Configured	...		<input type="checkbox"/>	%HSC2		Not Configured	...		<input type="checkbox"/>	%HSC3		Not Configured	...	
Used	Address	Symbol	Type	Configuration	Comment																										
<input type="checkbox"/>	%HSC0		Not Configured	...																											
<input type="checkbox"/>	%HSC1		Not Configured	...																											
<input type="checkbox"/>	%HSC2		Not Configured	...																											
<input type="checkbox"/>	%HSC3		Not Configured	...																											
2	<p>Click ... in the Configuration column to select the type of high speed counter and to display the High Speed Counter Assistant window.</p>																														

Configuring an Expert Output Function

To configure an expert output function, proceed as follows:

Step	Description																								
1	<p>Click the Pulse Generators node in the hardware tree. Result: The Pulse Generators list is displayed:</p> <table border="1"> <thead> <tr> <th colspan="6">Pulse Generators</th> </tr> <tr> <th>Configured</th> <th>Address</th> <th>Symbol</th> <th>Type</th> <th>Configuration</th> <th>Comment</th> </tr> </thead> <tbody> <tr> <td><input type="checkbox"/></td> <td>%PLS0/%PWM0/%PTO0/%FREQGEN0</td> <td></td> <td>Not Configured</td> <td>...</td> <td></td> </tr> <tr> <td><input type="checkbox"/></td> <td>%PLS1/%PWM1/%PTO1/%FREQGEN1</td> <td></td> <td>Not Configured</td> <td>...</td> <td></td> </tr> </tbody> </table>	Pulse Generators						Configured	Address	Symbol	Type	Configuration	Comment	<input type="checkbox"/>	%PLS0/%PWM0/%PTO0/%FREQGEN0		Not Configured	...		<input type="checkbox"/>	%PLS1/%PWM1/%PTO1/%FREQGEN1		Not Configured	...	
Pulse Generators																									
Configured	Address	Symbol	Type	Configuration	Comment																				
<input type="checkbox"/>	%PLS0/%PWM0/%PTO0/%FREQGEN0		Not Configured	...																					
<input type="checkbox"/>	%PLS1/%PWM1/%PTO1/%FREQGEN1		Not Configured	...																					
2	Click [...] in the Configuration column to select the type of pulse generator and to display the Pulse Train Output Assistant window.																								

Expert I/O Function Configuration Characteristics

- Inputs can be read through standard memory variables even if configured in association with expert I/O functions.
- Short-circuit management still applies on all expert outputs.
- All I/O that are not used by expert I/O functions can be used as regular I/O.
- Outputs used by the *Pulse*, *Pulse Train Output*, *Pulse Width Modulation*, and *High Speed Counters* can only be accessed through the expert I/O function block. They cannot be read or written directly within the application.

Embedded Expert I/O Mapping

Input Mapping for Expert Functions on M221 Logic Controller

Embedded digital inputs can be assigned to functions (Run/Stop, Latch, Event, Fast Counter, HSC, PTO). Inputs not assigned to functions are used as regular inputs. The following table presents the possible assignments of the embedded M221 Logic Controller digital inputs:

Function		Simple Input Function			Advanced Input Function		
		Run/Stop	Latch	Event	Fast Counter	HSC	PTO ⁽³⁾
Fast Input	%I0.0	X	–	–	–	%HSC0	–
	%I0.1	X	–	–	–	%HSC0 or %HSC2 ⁽¹⁾	–
Regular Input	%I0.2	X	X	X	%FC0	Preset for %HSC0	Ref or probe for %PTO0 to %PTO3
	%I0.3	X	X	X	%FC1	Catch for %HSC0	
	%I0.4	X	X	X	%FC2	Catch for %HSC1	
	%I0.5	X	X	X	%FC3	Preset for %HSC1	
Fast Input	%I0.6	X	–	–	–	%HSC1	–
	%I0.7	X	–	–	–	%HSC1 or %HSC3 ⁽²⁾	–
Regular Input (depending on the controller reference)	%I0.8	X	–	–	–	–	Ref or probe for %PTO0 to %PTO3 on TM221C40U and TM221CE40U controllers
	%I0.9	X	–	–	–	–	
	%I0.10	X	–	–	–	–	–
	%I0.11	X	–	–	–	–	–
	%I0.12	X	–	–	–	–	–
	%I0.13	X	–	–	–	–	–
	%I0.14	X	–	–	–	–	–
	%I0.15	X	–	–	–	–	–
	%I0.16	X	–	–	–	–	–
	%I0.17	X	–	–	–	–	–
	%I0.18	X	–	–	–	–	–
	%I0.19	X	–	–	–	–	–
	%I0.20	X	–	–	–	–	–
	%I0.21	X	–	–	–	–	–
%I0.22	X	–	–	–	–	–	
%I0.23	X	–	–	–	–	–	

X Yes

– No

⁽¹⁾ %HSC2 is available when %HSC0 is configured as *Single Phase* or *Not Configured*.

⁽²⁾ %HSC3 is available when %HSC1 is configured as *Single Phase* or *Not Configured*.

⁽³⁾ PTO function is available on controller references that contain transistor outputs.

Output Mapping for Expert Functions on M221 Logic Controller

The information below refers to regular and fast transistor outputs on M221 Logic Controller:

Function		Alarm Output	HSC	PLS / PWM / PTO / FREQGEN
Fast Output ⁽¹⁾	%Q0.0	X	–	<ul style="list-style-type: none"> • %PLS0 • %PWM0 • %PTO0 • %FREQGEN0
	%Q0.1	X	–	<ul style="list-style-type: none"> • %PLS1 • %PWM1 • %PTO⁽²⁾ • %FREQGEN1
Regular Output ⁽³⁾ (depending on the controller reference)	%Q0.2	X	Reflex output 0 for %HSC0 or %HSC2	<ul style="list-style-type: none"> • %PTO⁽⁴⁾ • %FREQGEN2
	%Q0.3	X	Reflex output 1 for %HSC0 or %HSC2	<ul style="list-style-type: none"> • %PTO⁽⁵⁾ • %FREQGEN3
	%Q0.4	X	Reflex output 0 for %HSC1 or %HSC3	%PTOx direction
	%Q0.5	X	Reflex output 1 for %HSC1 or %HSC3	%PTOx direction
	%Q0.6	X	–	%PTOx direction
	%Q0.7	X	–	%PTOx direction
	%Q0.8	–	–	%PTOx direction
	%Q0.9	–	–	%PTOx direction
	%Q0.10	–	–	%PTOx direction
	%Q0.11	–	–	%PTOx direction
	%Q0.12	–	–	%PTOx direction
	%Q0.13	–	–	%PTOx direction
	%Q0.14	–	–	%PTOx direction
	%Q0.15	–	–	%PTOx direction

X Yes

– No

⁽¹⁾ Fast output functions are only available on controller references that contain transistor outputs.

⁽²⁾ %PTO0 direction in CW/CCW output mode, or %PTO1 (not available when %PTO0 is configured in CW/CCW output mode), or %PTOx direction in other cases.

⁽³⁾ %Q0.2 and %Q0.3 are fast outputs on TM221C40U and TM221CE40U controllers

⁽⁴⁾ %PTO2 on TM221C40U and TM221CE40U controllers, or %PTOx direction in other cases.

⁽⁵⁾ %PTO2 direction in CW/CCW output mode on TM221C40U and TM221CE40U controllers, or %PTO3 (not available when %PTO2 is configured in CW/CCW output mode) on TM221C40U and TM221CE40U controllers, or %PTOx direction in other cases.

General Information on Function Block Management

Management of Function Block Inputs and Input Objects

The variables (function block inputs and input objects) are used with the rising edge of the *Execute* input. To modify any variable, it is necessary to change the input variables and to trigger the function block again. However, there are some function blocks that do provide a continuous update option.

Management of Function Block Outputs and Output Objects

The *Done*, *Error*, *Busy*, and *CmdAborted* outputs are mutually exclusive: only one of them can be TRUE on one function block. When the *Execute* input is TRUE, one of these outputs is TRUE.

At the rising edge of the *Execute* input, the *Busy* output is set to TRUE. It remains TRUE during the execution of the function block and is reset at the rising edge of one of the other outputs (*Done*, *Error* and *CmdAborted*).

The *Done* output is TRUE when the execution of the function block has completed successfully.

If an error is detected, the function block terminates by setting the *Error* output to TRUE, and the error code is contained within the *ErrId* output.

The *Done*, *Error*, and *CmdAborted* outputs are set to TRUE or FALSE with the falling edge of the *Execute* input, according to the following conditions:

- set for one task cycle if the function block execution is finished and the *Execute* input is FALSE and then reset to their default values.
- retain their value if the function block execution is finished and the *Execute* input is TRUE.

When an instance of a function block receives a new *Execute* before it is finished (as a series of commands on the same instance), the function block does not return any feedback, like *Done*, for the previous action. However, the new command is started on the function block (status is *Busy*).

Error Handling

All blocks have two outputs that can report errors detected during the execution of the function block:

- *Error*= The rising edge of this output indicates that an error was detected.
- *ErrID*= The error code of the error detected.

Advanced Expert Input Functions

What's in This Part

Fast Counter (%FC)	23
High Speed Counter (%HSC)	28

Overview

This part describes the advanced expert input functions.

Fast Counter (%FC)

What's in This Chapter

Description	23
Configuration	24
Programming Example	26

Using Fast Counter Function Blocks

This chapter provides descriptions and programming guidelines for using *Fast Counter* function blocks.

Description

Introduction

The *Fast Counter* function block ¹¹²³ serves as either an up-counter or a down-counter. It can count the rising edge of digital inputs up to frequencies of 5 kHz in single word or double word computational mode. Because *Fast Counter* function blocks are managed by specific hardware interrupts, maintaining maximum frequency sampling rates may vary depending on your specific application and hardware configuration.

The *Fast Counter* function blocks %FC0, %FC1, %FC2, and %FC3 use dedicated inputs %I0.2, %I0.3, %I0.4 and %I0.5 respectively. These bits are not reserved for their exclusive use. Their allocation must be considered with the use of other function blocks for these dedicated resources.

Illustration

This illustration is a *Fast Counter* function block in single-word mode:

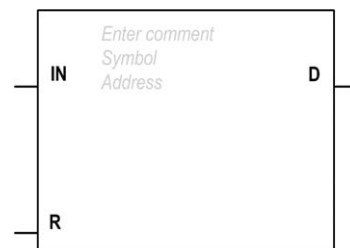

Inputs

The *Fast Counter* function block has the following inputs:

Label	Description	Value
IN	Enable	At state 1, the value is updated according to the pulses applied to the physical input. At state 0, the value is held at its last value.
R	Reset (optional)	Used to initialize the block. At state 1: <ul style="list-style-type: none"> • <i>%FC.P</i> or <i>%FC.PD</i> values are taken into account. • The value is reset to 0 if configured as an up-counter, or set to <i>%FC.P</i> or <i>%FC.PD</i> if configured as a down-counter. • The Done bit <i>%FC.D</i> is set back to its default value.

Outputs

The *Fast Counter* function block has the following output:

Label	Description	Value
D	Done (<i>%FCi.D</i>)	This bit is set to 1 when: <ul style="list-style-type: none"> • <i>%FCi.V</i> or <i>%FCi.VD</i> reaches the preset value <i>%FCi.P</i> or <i>%FCi.PD</i> configured as an up-counter. • or when <i>%FCi.V</i> or <i>%FCi.VD</i> reaches 0 when configured as a down-counter. This read-only bit is reset only by setting <i>%FCi.R</i> to 1.

Configuration

Parameters

To configure parameters, follow the Configuring a Function Block procedure (see EcoStruxure Machine Expert - Basic, Generic Functions Library Guide) and read the description of Memory Allocation Modes in the EcoStruxure Machine Expert - Basic Operating Guide (see EcoStruxure Machine Expert - Basic, Operating Guide).

The *Fast Counter* function block has the following parameters:

Parameter	Description	Value
Used	Address used	If selected, this address is currently in use in a program.
Address	<i>%FCi Fast Counter</i> address	The instance identifier, where it is from 0 to the number of objects available on this logic controller. Refer to Maximum Number of Objects table (see Modicon M221, Logic Controller, Programming Guide) for the maximum number of <i>Fast Counters</i> .
Input	<i>%IO.i</i>	The dedicated input associated with this function block instance. <i>%IO.2...%IO.5</i>
Symbol	Symbol	The symbol associated with this object. Refer to the EcoStruxure Machine Expert - Basic Operating Guide (Defining and Using Symbols) for details.
Configured	Whether to count up or down	Set to one of: <ul style="list-style-type: none"> • Not used • Up Counter • Down Counter
Preset	Preset value (<i>%FCi.P</i> or <i>%FCi.PD</i>)	Initial value may be set: <ul style="list-style-type: none"> • Using associated object <i>%FCi.P</i> from 1 to 65535 in single word mode, • Using associated object <i>%FCi.PD</i> from 1 to 4294967295 in double word mode.
Double Word	Double word mode	If selected, use double word mode. Otherwise, use single-word mode.
Comment	Comment	An optional comment can be associated with this object. Double-click in the Comment column and type a comment.

Objects

The *Fast Counter* function block is associated with the following objects:

Object	Description	Value
<i>%FCi.V</i> <i>%FCi.VD</i>	Current value	The current value increments or decrements according the up or down counting function selected. For up-counting, the current counting value is updated and can reach 65535 in single word mode (<i>%FCi.V</i>) and 4294967295 in double word mode (<i>%FCi.VD</i>). For down-counting, the current value is the preset value <i>%FC.P</i> or <i>%FC.PD</i> and can count down to 0.
<i>%FCi.P</i> <i>%FCi.PD</i>	Preset value	A new preset value is taken into account only if the R input is active. See description in Parameters table above.
<i>%FCi.D</i>	Done	See description in Outputs table above.

Operation

This table describes the main stages of *Fast Counter* function block operations:

Operation	Action	Result
Count up	A rising edge appears at the Count up input.	The current value %FCi.V is incremented by 1 unit.
	When the preset value %FCi.P or %FCi.PD is reached.	The Done output bit %FCi.D is set to 1.
Count down	A rising edge appears at the down-counting input.	The current value %FCi.V is decremented by 1 unit.
	When the value is 0.	The Done output bit %FCi.D is set to 1.

Special Cases

This table contains a list of special operating cases for the *Fast Counter* function block:

Special Case	Description
Effect of cold restart (%S0=1)	Resets the <i>Fast Counter</i> attributes with the values configured or user application (see Modicon M221, Logic Controller, Programming Guide).
Effect of warm restart (%S1=1)	No effect (see Modicon M221, Logic Controller, Programming Guide).
Effect of controller stops	The <i>Fast Counter</i> stops counting when the controller is set to <i>STOPPED</i> state and resumes counting when it returns to <i>RUNNING</i> state. The counter resumes counting from the last value before entering the <i>STOPPED</i> state.

Programming Example

Introduction

In this example, the application counts a number of items up to 5000 while %I0.1 is set to 1. The input for %FC1 is the dedicated input %I0.3. When the preset value is reached, %FC1.D is set to 1 and retains the same value until %FC1.R is commanded by the result of AND on %I0.2 and %M0.

Programming

This example is a *Fast Counter* function block:

Rung	Instruction
0	BLK %FC1 LD %I0.1 IN LD %I0.2 AND %M0 R OUT_BLK LD D ST %Q0.0 END_BLK

NOTE: Refer to the reversibility procedure (see EcoStruxure Machine Expert - Basic, Generic Functions Library Guide) to obtain the equivalent Ladder Diagram.

High Speed Counter (%HSC)

What's in This Chapter

Description	28
High Speed Counter in Counting Modes.....	32
High Speed Counter in Frequency Meter Mode	38

Using High Speed Counter Function Blocks

This chapter provides descriptions and programming guidelines for using *High Speed Counter* function blocks.

Description

Introduction

The *High Speed Counter* function block **11123** can be configured by EcoStruxure Machine Expert - Basic to perform any one of the following functions:

- Dual Phase [Pulse / Direction]
- Dual Phase [Quadrature X1]
- Dual Phase [Quadrature X2]
- Dual Phase [Quadrature X4]
- Single Phase
- Frequency Meter

The *High Speed Counter* function block works at a maximum frequency of 100 kHz for all counting modes with a range of 0 to 65535 in single word and 0 to 4294967295 in double word.

The *High Speed Counter* function block uses dedicated inputs and auxiliary inputs and outputs. Refer to the M221 Logic Controller - Hardware Guide for more information on inputs and outputs.

You must initialize the *High Speed Counter* function in the **Configuration** tab using the **High Speed Counter Assistant** before using an instance of the function block. Refer to Configuring High Speed Counters (see Modicon M221, Logic Controller, Programming Guide).

Graphical Representation

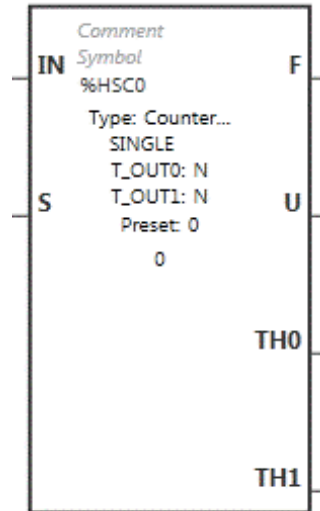

Inputs

The *High Speed Counter* function block has the following inputs:

Label	Description	Value
IN	<p>Enable (required)</p> <p>At state 1, the counting function or frequency measurement is enabled.</p> <p>At state 0, the present value is held at its last value.</p>	0 or 1
S	<p>Preset input.</p> <p>At state 1:</p> <ul style="list-style-type: none"> • initializes the value with the preset value for: <ul style="list-style-type: none"> ◦ Dual Phase [Quadrature X1], ◦ Dual Phase [Quadrature X2], ◦ Dual Phase [Quadrature X4], or ◦ Dual Phase [Pulse / Direction] with down function in progress • resets the value to 0 for: <ul style="list-style-type: none"> ◦ Single Phase, or ◦ Dual Phase [Pulse / Direction] with up function in progress <p>In addition, this also initializes the operation of the threshold outputs and takes into account any user modifications to the threshold values set in the properties window or the program.</p>	0 or 1

The *High Speed Counter* function block is associated with the following input objects:

Object	Type	Description	Value
%HSCi.P %HSCi.PD	WORD DOUBLE WORD	Preset value	Refer to Auxiliary Inputs, page 33.
%HSCi.S0 %HSCi.S0D	WORD DOUBLE WORD	Threshold 0	Refer to Output Threshold in Counting Modes, page 32.
%HSCi.S1 %HSCi.S1D	WORD DOUBLE WORD	Threshold 1	Refer to Output Threshold in Counting Modes, page 32.
%HSCi.T	WORD	Time base	Refer to High Speed Counter in Frequency Meter Mode, page 38.
%HSCi.R	BOOL	Enable reflex output 0	At state 1 enables the reflex output 0.
%HSCi.S	BOOL	Enable reflex output 1	At state 1 enables the reflex output 1.

NOTE: The %HSCi.R and %HSCi.S bits respectively enable or disable the reflex outputs only if the HSC function block is enabled, that is, if %HSCi.IN is set to 1.

Outputs

The *High Speed Counter* function block has the following outputs:

Label	Description	Value
F	Overflow Set to 1 if an arithmetic overflow occurs.	0 or 1
U	Counting direction Set by the system, this bit is used by the <i>Dual Phase</i> counting functions to indicate the direction of counting.	0: Down counting 1: Up counting
TH0	Threshold bit 0 Set to 1 when the present value is greater than or equal to the threshold value S0 (%HSCi.S0). Test this bit only once in the program because it is updated in real time. The user application is responsible for the validity of the value at its time of use.	0 or 1
TH1	Threshold bit 1 Set to 1 when the present value is greater than or equal to the threshold value S1 (%HSCi.S1). Test this bit only once in the program because it is updated in real time.	0 or 1

The *High Speed Counter* function block is associated with the following output objects:

Object	Type	Description	Value
%HSCi.V %HSCi.VD	WORD DOUBLE WORD	Present value	Refer to High Speed Counter in Counting Modes, page 32 and to High Speed Counter in Frequency Meter Mode, page 38. NOTE: The present value can be updated independently of the %HSC function block call. %HSCi.V/%HSCi.VD can be read twice and have different results in the same task cycle.
%HSCi.C %HSCi.CD	WORD DOUBLE WORD	Capture value	Refer to Auxiliary Inputs, page 33.
%HSCi.U	BOOL	Counting direction	0: Down counting 1: Up counting
%HSCi.F	BOOL	Overflow	0: No overflow 1: Counter overflow

Properties

The *High Speed Counter* function block has the following properties:

Property	Value	Description
Used	Activated / deactivated checkbox	Indicates whether the address is in use.
Address	%HSCi, where <i>i</i> is from 0 to 3, depending on the type(s) of counters configured	<i>i</i> is the instance identifier. For the maximum number of %HSC objects, refer to the table Maximum Number of Objects (see Modicon M221, Logic Controller, Programming Guide).
Symbol	User-defined text	The symbol that uniquely identifies this object. For details, refer to Defining and Using Symbols (see EcoStruxure Machine Expert - Basic, Operating Guide).
Preset	<ul style="list-style-type: none"> from 0 to 65535 for %HSCi.P from 0 to 4294967295 for %HSCi.PD 	Preset value to initialize the HSC present value (%HSCi.P, %HSCi.PD). Not valid for the <code>FrequencyMeter</code> .
S0	<ul style="list-style-type: none"> from 1 to 65535 for %HSCi.S0 from 1 to 4294967295 for %HSCi.S0D 	Threshold 0 value is used as a comparator with the present value. The value of S0 must be less than S1 (%HSCi.S1).
S1	<ul style="list-style-type: none"> from 2 to 65535 for %HSCi.S1 from 2 to 4294967295 for %HSCi.S1D 	Threshold 1 value is used as a comparator with the present value. The value of S1 must be greater than S0 (%HSCi.S0).
Time Base	100 ms or 1 s for %HSCi.T	Frequency measurement time base.
Comment	User-defined text	A comment to associate with this object.

Special Cases

This table shows a list of special operating of the *High Speed Counter* function block:

Special Case	Description
Effect of cold restart (%S0=1)	Resets the <i>High Speed Counter</i> attributes with the values configured by the program.
Effect of warm restart (%S1=1)	Has no effect.
Effect of controller stop	The <i>High Speed Counter</i> stops its function and the outputs stay in their present state. NOTE: When the controller stops, the reflex outputs are set to 0 if Maintain values is selected for the outputs. Otherwise, if Maintain values is not selected, the reflex outputs take the fallback values. For more information on configuring fallback behavior, refer to Fallback Behavior (see EcoStruxure Machine Expert - Basic, Operating Guide).

High Speed Counter in Counting Modes

Introduction

The *High Speed Counter* function block works at a maximum frequency of 100 kHz for all counting modes with a range of 0 to 65535 in single word and 0 to 4294967295 in double word.

The pulses to be counted are applied in the following way:

Function	Description	Input type	%HSC0	%HSC1	%HSC2	%HSC3
Dual Phase [Pulse / Direction]	The pulses are applied to the physical input associated to Pulse Input .	Pulse Input	%I0.0	%I0.6	–	–
	The present operation (upcount/ downcount) is given by the state of the Direction Input : <ul style="list-style-type: none"> 0 = up counting 1 = down counting 	Direction Input	%I0.1	%I0.7	–	–
Dual Phase [Quadrature X1], Dual Phase [Quadrature X2], Or Dual Phase [Quadrature X4]	The 2 phases of the encoder are applied to physical inputs associated to Pulse Input Phase A and Pulse Input Phase B .	Pulse Input Phase A	%I0.0	%I0.6	–	–
		Pulse Input Phase B	%I0.1	%I0.7	–	–
Single Phase	The pulses are applied to the physical input associated to Pulse Input .	Pulse Input	%I0.0	%I0.6	%I0.1	%I0.7

NOTE: I/O assignment is different between the Twido platform and M221 Logic Controller range. On the M221 Logic Controller, the main pulse input is %I0.0 for %HSC0 and %I0.6 for %HSC1. On the Twido platform, the main pulse input is %I0.1 for %HSC0 and %I0.7 for %HSC1.

Output Thresholds

During counting, the current value is compared to two thresholds: %HSCi.S0 or %HSCi.S0D and %HSCi.S1 or %HSCi.S1D.

Modifications to these threshold values are taken into account regardless of the value of the **Preset** input.

Threshold value modifications are saved in the logic controller (*%HSCi.S0*, *%HSCi.S1*, *%HSCi.S0D* and *%HSCi.S1D* objects), but not in the **Configuration** window of EcoStruxure Machine Expert - Basic.

According to the result of the comparisons, the bit objects, *%HSCi.TH0* and *%HSCi.TH1*, are:

- set to 1 if the current value is greater than or equal to the corresponding threshold
- reset to 0 if the current value is less than the corresponding threshold.

Physical reflex outputs can be configured to respond differentially within the context of the compare results of the threshold values and the current value of the counters.

NOTE: None, 1 or 2 reflex outputs can be configured.

For more information on the configuration of reflex outputs, refer to Configuring Dual Phase and Single Phase Counters (see Modicon M221, Logic Controller, Programming Guide).

%HSCi.U is an output of the function block; it gives the direction of the associated counter variation (1 for UP, 0 for DOWN).

Auxiliary Inputs

Counting operations are made on the rising edge of pulses, and only if the counting function block is enabled (**IN** input at state 1).

There are two optional inputs used in counting mode: **Catch Input** and **Preset Input**:

- A rising edge of the **Catch Input** is used to capture the current value (*%HSCi.V* or *%HSCi.VD*) and store it in *%HSCi.C* or *%HSCi.CD*. The catch inputs are specified as *%I0.3* for *%HSC0* and *%I0.4* for *%HSC1* if available.
- A rising edge of the **Preset Input** initializes *%HSCi.V* or *%HSCi.VD* value with the preset value for:
 - Dual Phase [Quadrature X1]
 - Dual Phase [Quadrature X2]
 - Dual Phase [Quadrature X4]
 - Dual Phase [Pulse / Direction] with down function in progress

The **Preset Input** resets the value to 0 for:

- Single Phase
- Dual Phase [Pulse / Direction] with up function in progress

If the auxiliary **Preset Input** is set to 1 with the input *IN* at 0 (the function is inhibited), the outputs are not monitored and maintain their values.

NOTE: *%HSCi.F* is also set to 0. The **Preset Input** is specified as *%I0.2* for *%HSC0* and/or *%I0.5* for *%HSC1*.

Operation

This illustration is the operation diagram of the counting mode in single word mode (in double word mode, use the double word function variables):

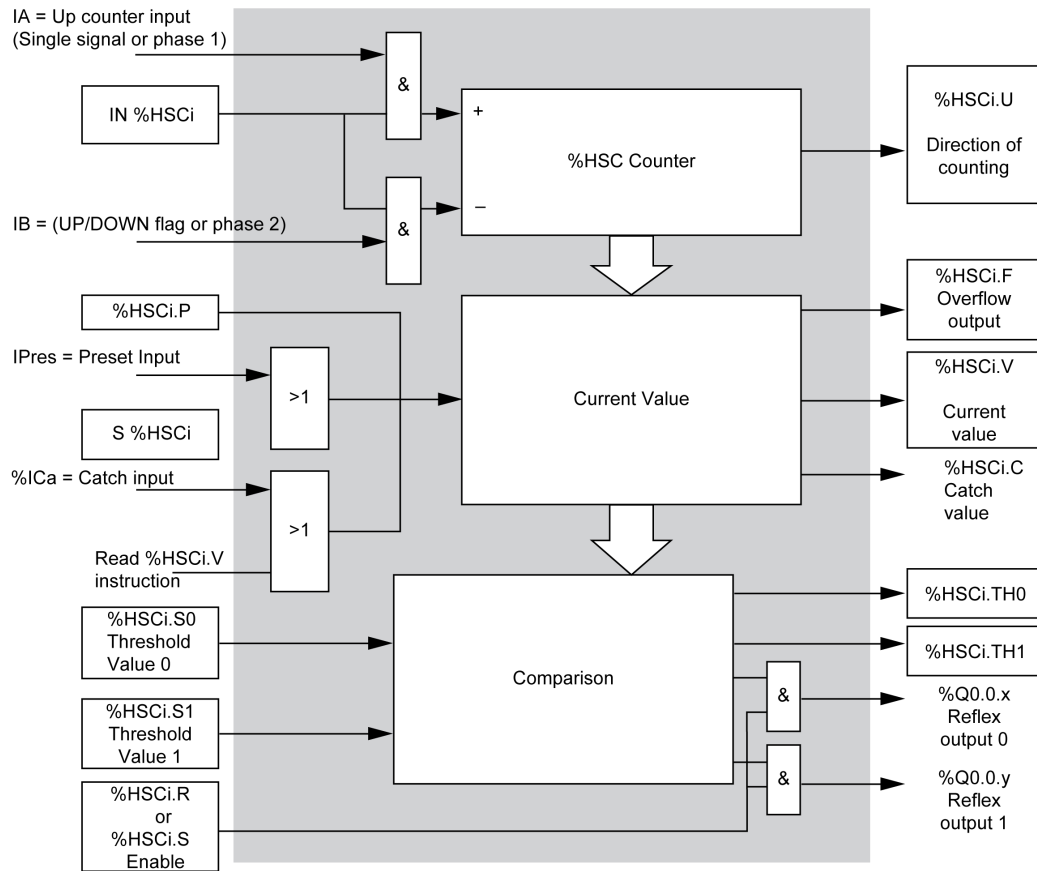

NOTE: Reflex outputs are managed independently from the controller cycle time.

Dual Phase [Pulse / Direction] Timing Diagram

Reflex output configuration example:

Reflex Output	Value < %HSC0.S0	%HSC0.S0 <= Value < %HSC0.S1	Value >= %HSC0.S1
%Q0.2	0	0	1
%Q0.3	1	1	0

Timing diagram:

%HSC0.P = 17
 %HSC0.S0 = 14
 %HSC0.S1 = 20

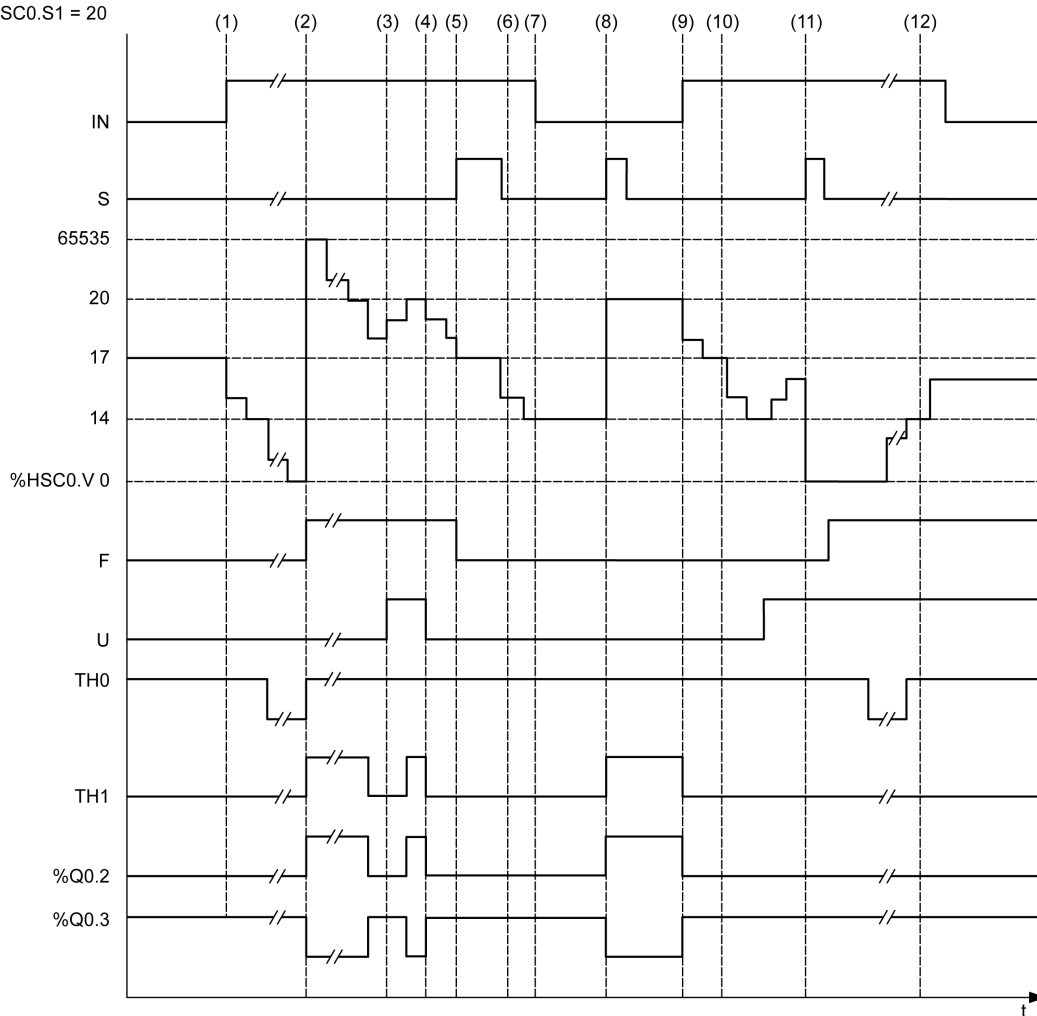

- (1) Input IN is set to 1 so down-counting mode starts (%HSC0.U = 0 that is, IB = 1)
- (2) The current value reaches 0 so F output flag is set to 1 and %HSC0.V is set to 65535 at the next count
- (3) Change at the IB input, the counter is now in up counting mode and %HSC0.U = 1
- (4) IB input is set to 1 so the counter is in down counting mode and %HSC0.U is set to 0
- (5) Input S is set to 1 while down counting is in progress, so %HSC0.V is initialized to the Preset value %HSC0.P = 17
- (6) S is reset to 0 and the preset value %HSC0.P is changed to 20
- (7) The input IN is set to 0 so the function is inhibited, %HSC0.V is held
- (8) S is set to 1 so the new preset value (%HSC0.P = 20) is taken into account and the reflex outputs are updated. **Note:** If an auxiliary preset input is used instead of S, the reflex outputs are not updated in accordance with the Twido family of controllers.
- (9) IN input is set to 1 and the function restarts in down counting mode
- (10) The threshold value %HSC0.S1 is set to 17
- (11) S input active makes threshold S1 new value to be granted at the next count and resets %HSC0.V to 0
- (12) A catch of the current value %HSC0.V is made so %HSC0.C = 14

NOTE: %HSC0.R and %HSC0.S must be set to TRUE to have the configured reflex outputs active.

Dual Phase [Quadrature X1], Dual Phase [Quadrature X2], Dual Phase [Quadrature X4] Timing Diagram

A physical encoder provides two 90° shifted signals that allow the counter to count pulses and detect direction:

X1	1 count for each encoder cycle
X2	2 counts for each encoder cycle
X4	4 counts for each encoder cycle

Timing diagram:

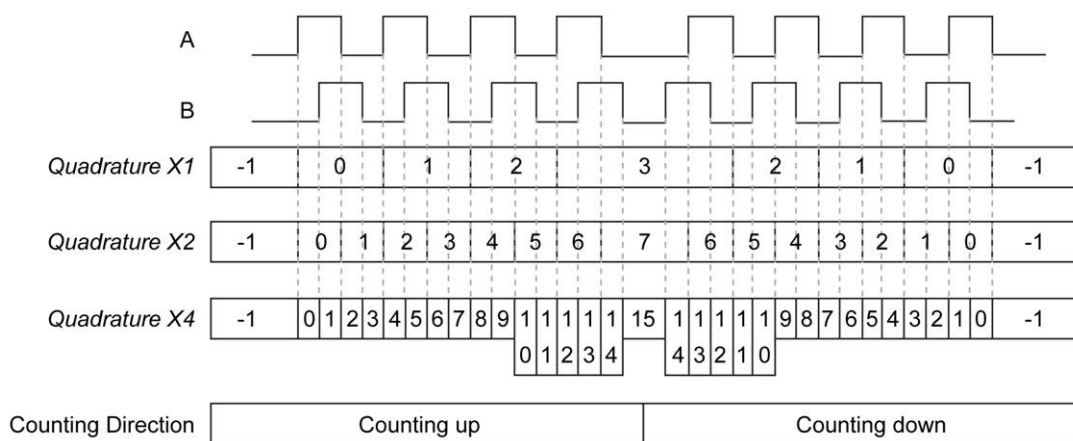

Quadrature X1 When channel A leads channel B, the counter increments on the rising edge of channel A. When channel B leads channel A, the counter decrements on the falling edge of channel A.

Quadrature X2 Counter increments or decrements on each edge of channel A, depending on which channel leads the other. Each cycle results in two increments or decrements.

Quadrature X4 The counter increments or decrements on each edge of channels A and B. Whether the counter increments or decrements depends on which channel leads the other. Each cycle results in 4 increments or decrements.

Single Phase Timing Diagram

Reflex output configuration example:

Reflex Output	Value < %HSC0.S0	%HSC0.S0 <= Value < %HSC0.S1	Value >= %HSC0.S1
%Q0.2	0	1	0
%Q0.3	1	0	1

Timing diagram:

%HSC0.P = 17
 %HSC0.S0 = 14
 %HSC0.S1 = 20

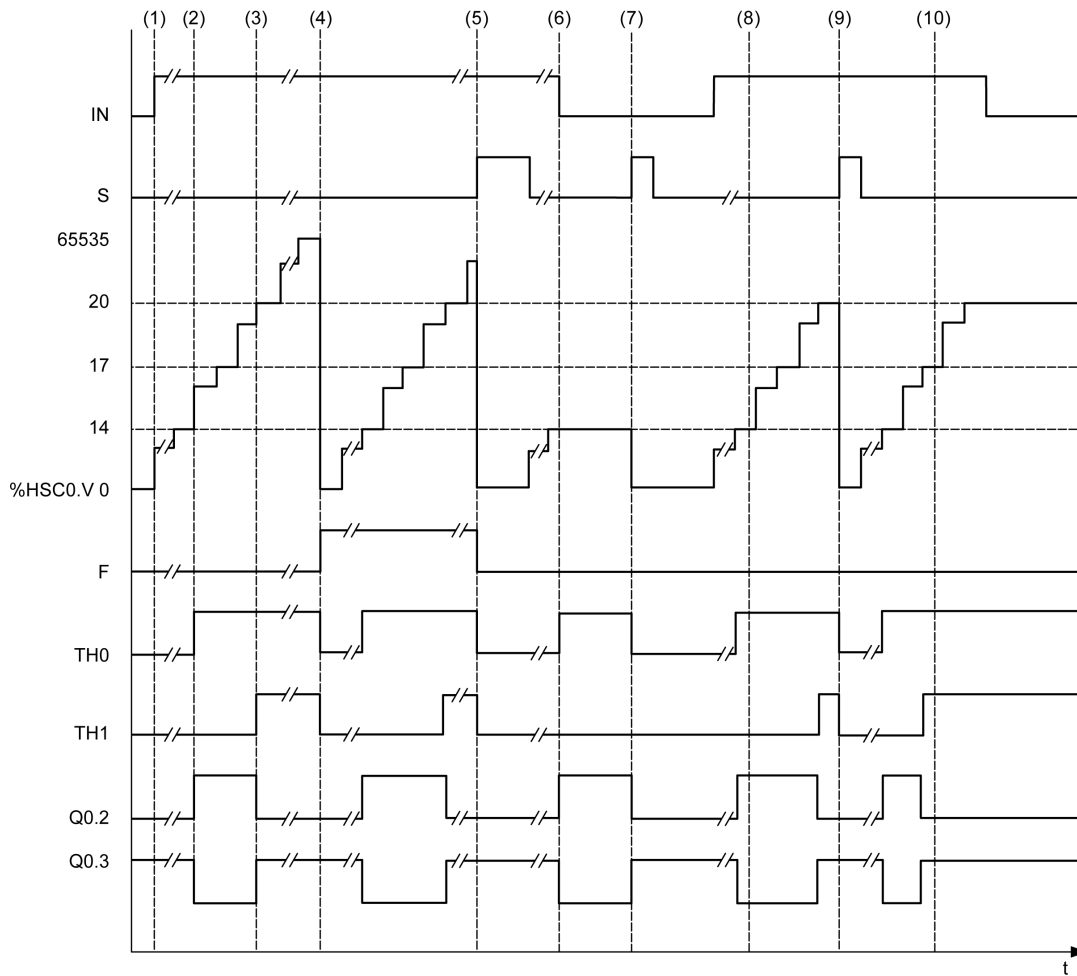

- (1) IN is set to 1: the counting function is activated (%HSC0.U = 1 because %HSC0 is an up-counter)
- (2) %Q0.2 (Reflex Output) and TH0 are set to 1
- (3) TH1 is set to 1
- (4) The maximum value is reached so on the next count %HSC0.V is reset to 0 and F is set to 1
- (5) S is set to 1, the current value, %HSC0.V, is set to 0
- (6) The current function is inhibited while IN is set to 0
- (7) While the function is inhibited, S is set to 1 so the current value is reset to 0
- (8) Change of threshold value S1 to 17
- (9) S is set to 1 so the new value of S1 will be granted at the next count
- (10) Catch input is set to 1 so %HSC0.C = 17

High Speed Counter in Frequency Meter Mode

Introduction

The frequency meter mode of an *High Speed Counter* is used to measure the frequency of a periodic signal in Hz on input IA (pulse input phase A).

The frequency range which can be measured is 1 Hz to 100 kHz with a range of 0 to 4294967295 in double word mode.

It is possible to choose between 2 time bases, the choice being made by the object `%HSC.T` (Time base):

Time Base	Accuracy	Update
100 ms	0.01% for 100 kHz 10% for 100 Hz	10 times per second
1 s	0.001% for 100 kHz 10% for 10 Hz	Once per second

Accuracy Measurement

$$Accuracy(\%) = \frac{1}{f[Hz]} \times \frac{1}{TB[s]} \times 100$$

Operation

This illustration is the operation diagram of the frequency meter mode:

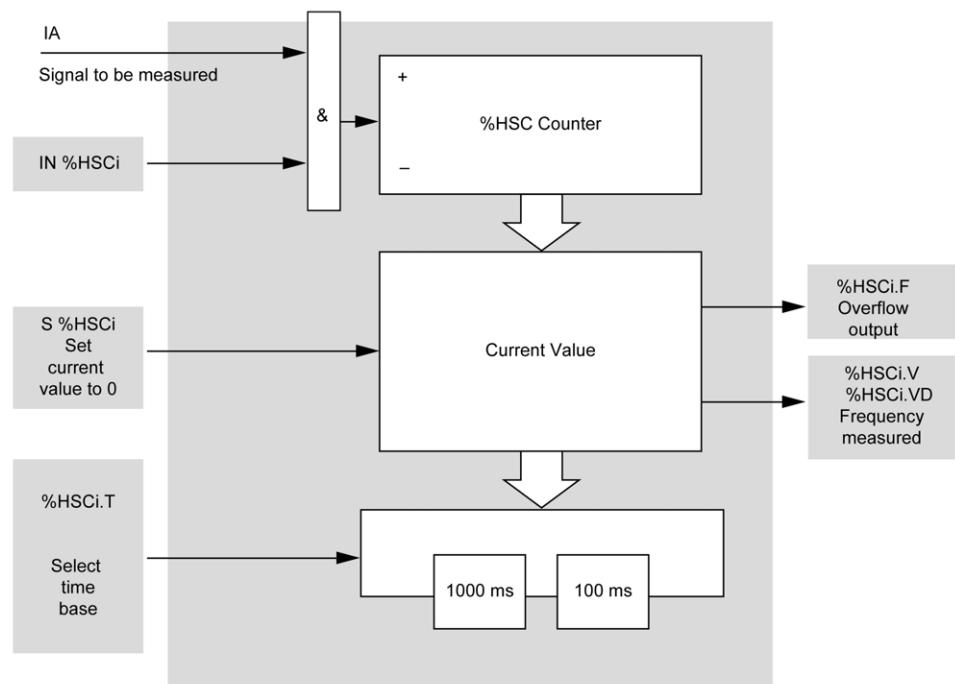

Timing Diagram

This timing diagram is an example of using a *High Speed Counter* in frequency meter mode:

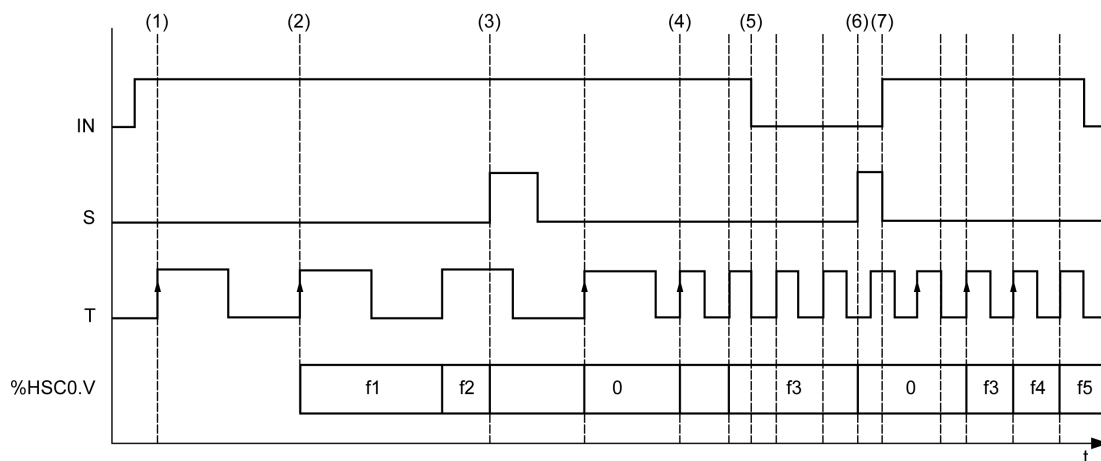

- (1) The first frequency measurement starts at a rising edge of the *TB* signal
- (2) *%HSC0.V* (or *%HSC0.VD*) is updated after one period of the *TB*
- (3) Input *IN* and input *S* are set to 1 so *%HSC0.V* (or *%HSC0.VD*) is set to 0
- (4) *%HSC0.T* is set to 100 ms, so the measurement is canceled and a new one starts
- (5) Input *IN* is set to 0, so the frequency measurement function is inhibited and *%HSC0.V* (or *%HSC0.VD*) is held
- (6) *S* is set to 1, so the value *%HSC0.V* (or *%HSC0.VD*) is set to 0
- (7) *S* is set to 0 and *IN* is set to 1, so the measurement will start at the next rising edge of the *TB* signal

Advanced Expert Output Functions

What's in This Part

Pulse (%PLS)	41
Pulse Width Modulation (%PWM)	47
Drive (%DRV)	52
Pulse Train Output (%PTO).....	75
Frequency Generator (%FREQGEN).....	145

Overview

This part describes the advanced expert output functions.

Pulse (%PLS)

What's in This Chapter

Description41
 Function Block Configuration.....42
 Programming Example46

Using Pulse Function Blocks

This chapter provides descriptions and programming guidelines for using *Pulse* function blocks.

Description

Introduction

The *Pulse* function block  is used to generate square wave signals.

Two *Pulse* function blocks are available on the dedicated output channel %Q0.0 or %Q0.1. Logic controllers with relay outputs for these two channels do not support the *Pulse* function block. Refer to the M221 Logic Controller - Hardware Guide for more information on inputs and outputs.

The *Pulse* function block allows only a single signal width, or duty cycle, of 50%.

You can choose to limit either the number of pulses or the period when the pulse train is executed. These factors can be determined at the time of configuration and/or updated by the program.

You must configure the *Pulse* function block in the **Configuration > Pulse Generators** before using an instance of the function block, refer to Configuring Pulse Generators (see Modicon M221, Logic Controller, Programming Guide).

The PLS function has the following characteristics:

Characteristic	Value
Number of channels	2
Minimum frequency	1 Hz
Maximum frequency	10000 Hz
Accuracy on frequency	1 %

Illustration

This illustration is a *Pulse* function block:

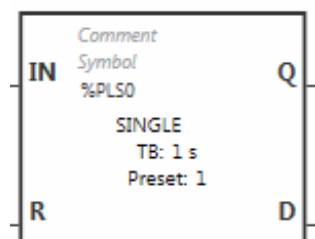

Inputs

The *Pulse* function block has the following inputs:

Label	Description	Value
IN	Enable	At state 1, the pulse is produced at the dedicated output channel. At state 0, the output channel is set to 0.
R	Reset to 0 (optional)	At state 1, outputs <i>%PLSi.Q</i> and <i>%PLSi.D</i> are set to 0. The number of pulses generated in period T is set to 0.

Outputs

The *Pulse* function block has the following outputs:

Label	Object	Description	Value
Q	<i>%PLSi.Q</i>	Generation in progress	At state 1, indicates that the <i>Pulse</i> signal is generated at the dedicated output channel configured.
D	<i>%PLSi.D</i>	Generation complete (optional)	At state 1, signal generation is complete. The number of desired pulses has been reached.

Function Block Configuration

Overview

To configure the *Pulse Generator* resource, refer to *Configuring Pulse Generators* (see *Modicon M221, Logic Controller, Programming Guide*).

To configure the *Pulse Generator* resource as a PLS, refer to *Configuring Pulse* (see *Modicon M221, Logic Controller, Programming Guide*).

Parameters

The *Pulse* function block has the following parameters:

Parameter	Description	Value
Used	Address used	If selected, this address is currently in use in a program.
Address	<i>%PLSi</i> <i>Pulse</i> address	The instance identifier, where <i>i</i> is from 0 to the number of objects available on this logic controller. For the maximum number of <i>Pulse</i> objects, refer to the table Maximum Number of Objects (see Modicon M221, Logic Controller, Programming Guide).
Symbol	Symbol	The symbol associated with this object. For details, refer to Defining and Using Symbols (see EcoStruxure Machine Expert - Basic, Operating Guide).
Preset	Preselection of the period (<i>%PLSi.P</i>)	<ul style="list-style-type: none"> Time Base = 1 s, <i>%PLSi.P</i>=1 or 2 Time Base = 10 ms, $1 \leq \%PLSi.P \leq 200$ Time Base = 1 ms, $1 \leq \%PLSi.P \leq 2000$ Time Base = 0.1 ms, $1 \leq \%PLSi.P \leq 20000$
Num. Pulse	Number of pulses (<i>%PLSi.N</i> , <i>%PLSi.ND</i>)	To produce an unlimited number of pulses, set <i>%PLS.N</i> or <i>%PLS.ND</i> to 0.
Current	Current output (<i>%PLSi.Q</i>)	0 or 1.
Done	Done pulse (<i>%PLSi.D</i>)	At state 1, signal generation is complete. The number of desired pulses has been reached. It is reset by either setting the IN or the R inputs to 1.
Comment	Comment	An optional comment can be associated with this object. Double-click in the Comment column and type a comment.

Objects

The *Pulse* function block is associated with the following objects:

Object	Description	Size (bit)	Default Value	Range	
<i>%PLSi.P</i>	Preset value	16	Preset (set on Configuration > Pulse Generators)	Preset <i>%PLSi.P</i>	Time Base
				1...20000	0.1 ms
				1...2000	1 ms
				1...200	10 ms
				1 or 2	1 s (default)
<i>%PLSi.N</i>	Number of pulses	16	0	0...32767	
<i>%PLSi.ND</i>		32	0	0...2147483647	

Rules of Use

The output signal period *T* is set with **Preset** and the **Time Base** parameters such as $T = \%PLSi.P \times \text{Time Base}$.

This table shows the range of available periods:

Time Base	Frequency
0.1 ms	0.5 Hz...10000 Hz
1 ms	0.5 Hz...1000 Hz
10 ms	0.5 Hz...100 Hz
1 s	0.5 Hz...1 Hz

The **Time Base** is set on the **Configuration > Pulse Generators** and cannot be modified. For more details, refer to *Configuring Pulse Generators* (see Modicon M221, Logic Controller, Programming Guide).

If $\%PLSi.P$ is:

- changed, the output signal period is changed at the end of the current period.
- set to 0, the pulse generation function is stopped.
- out of range, the parameter is forced to 0 and the pulse generation function is stopped.

If $\%PLSi.N$ (or $\%PLSi.ND$ in **Double Word** mode) is:

- changed, the number of pulse to be generated is used at the next execution of the pulse generation function ($\%PLSi.D = 1$ or after $\%PLSi.R = 1$).
- set to 0, unlimited number of pulse are generated.
- out of range, the parameter is forced to 0.

Timing Diagram

This diagram displays the timing for *Pulse* function block:

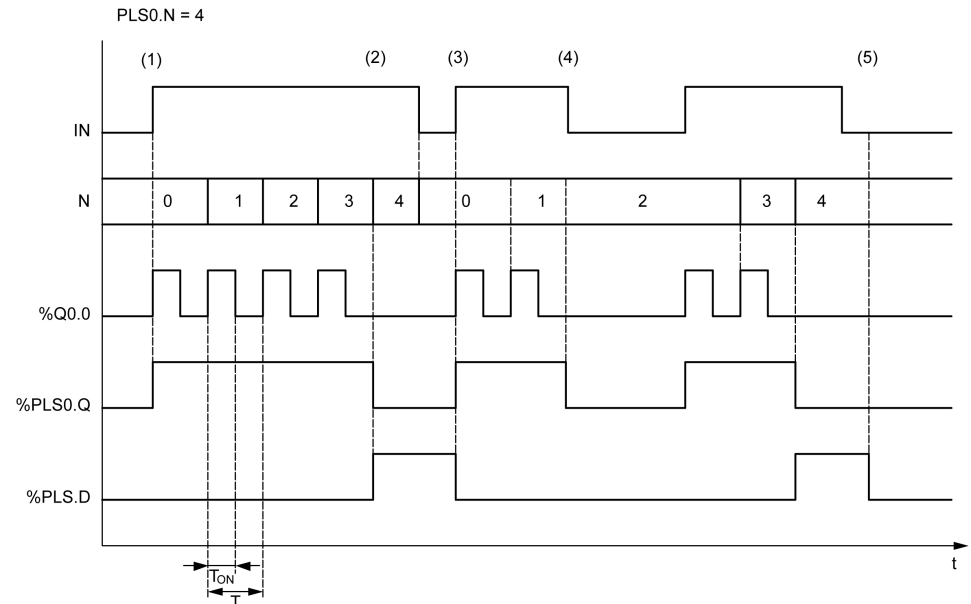

(1) *IN* input is set to 1, the pulse signal is generated at the dedicated output ($\%Q0.0$) so $\%PLSi.Q$ is set to 1

(2) The number of pulses reaches $\%PLS0.N (=4)$ so the Done flag output ($\%PLS0.D$) is set to 1 and the pulse generation is stopped ($\%PLS0.Q = 0$)

(3) *IN* input is set to 1 so $\%PLS0.D$ is reset to 0

(4) *IN* input is set to 0 so the output channel is set to 0 and $\%PLS0.Q = 0$ indicates that the signal generation is not active

(5) $\%PLS0.D$ is set to 0 by setting *R* input to 1

Special Cases

Special Case	Description
Effect of cold restart (%S0=TRUE)	<ul style="list-style-type: none"> • Pulse generation is stopped. • During the controller initialization, output is reset to 0. • If after the controller initialization: <ul style="list-style-type: none"> ◦ the controller enters the <i>STOPPED</i> state, the configured fallback strategy is applied to the output. ◦ the controller enters the <i>RUNNING</i> state, the configuration parameters are restored.
Effect of warm restart (%S1=TRUE)	<ul style="list-style-type: none"> • Pulse generation is stopped. • During the controller initialization, output is reset to 0. • If after the controller initialization: <ul style="list-style-type: none"> ◦ the controller enters the <i>STOPPED</i> state, the configured fallback strategy is applied to the output. ◦ the controller enters the <i>RUNNING</i> state, the configuration parameters are restored; however, the number of pulses that may have already been sent is reset to 0.⁽¹⁾
Effect at controller stop	<ul style="list-style-type: none"> • Pulse generation is stopped. • The fallback behavior depends on the configured fallback strategy: <ul style="list-style-type: none"> ◦ Maintain value: the outputs are reset to 0. ◦ Fallback value: the outputs are set to the fallback configured values (see EcoStruxure Machine Expert - Basic, Operating Guide).
Effect of online modification	None
Effect of a short-circuit or over-current on an output addressed by the <i>Pulse</i> function block while generating a limited number of pulses	<ul style="list-style-type: none"> • Pulse generation is stopped. • Once the short-circuit or over-current has been corrected, pulse generation resumes the sequence from where it was stopped.
<p>⁽¹⁾ If there is an ongoing pulse output instruction affective at the time of the warm restart, the pulse generation, upon controller restart, will not take into account the number of pulses sent prior to the warm restart.</p>	

WARNING

UNINTENDED EQUIPMENT OPERATION

- Avoid issuing a warm restart command (%S1=TRUE) while an ongoing PLS command is active.
- If a warm restart is unavoidable, you must take into account any pulses that were sent prior to the warm restart.

Failure to follow these instructions can result in death, serious injury, or equipment damage.

Programming Example

Introduction

The *Pulse* function block can be configured as in this programming example.

Programming

This example is a *Pulse* function block:

Rung	Instruction
0	BLK %PLS0 LD %M1 IN LD %M0 R OUT_BLK LD Q ST %Q0.5 LD D ST %M10 END_BLK

NOTE: Refer to the reversibility procedure (see EcoStruxure Machine Expert - Basic, Generic Functions Library Guide) to obtain the equivalent Ladder Diagram.

Pulse Width Modulation (%PWM)

What's in This Chapter

Description47
 Function Block Configuration.....48
 Programming Example 51

Using Pulse Width Modulation Function Blocks

This chapter provides descriptions and programming guidelines for using *Pulse Width Modulation* function blocks.

Description

Introduction

The *Pulse Width Modulation* function block  generates a variable wave signal on a dedicated output channel, %Q0.0 or %Q0.1, with variable width and, therefore, duty cycle.

Controllers with relay outputs for these two channels do not support this function.

%PWM0 uses dedicated output %Q0.0 and %PMW1 uses dedicated output %Q0.1. The Pulse function blocks %PLS can also be configured to use these same dedicated outputs. You can configure one or the other of these two functions, but not both, for any given dedicated output.

You must configure the *Pulse Width Modulation* function block in the **Configuration > Pulse Generators** before using an instance of the function block. Refer to *Configuring Pulse Generators* (see Modicon M221, Logic Controller, Programming Guide).

The PWM function has the following characteristics:

Characteristic	Value
Number of channels	2
Minimum frequency	1 Hz
Maximum frequency	10000 Hz
Accuracy on frequency	1 %

Illustration

This illustration presents the *Pulse Width Modulation* function block:

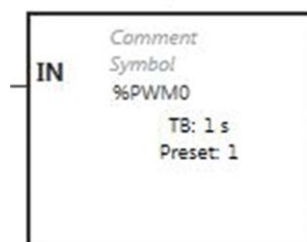

Inputs

The *Pulse Width Modulation* function block has the following input:

Label	Object	Description	Value
IN	%PWMi.IN	Enable	At state 1, the <i>Pulse Width Modulation</i> signal is generated at the output channel. At state 0, the output channel is set to 0.

Function Block Configuration

Overview

To configure the *Pulse Generator* resource, refer to *Configuring Pulse Generators* (see *Modicon M221, Logic Controller, Programming Guide*).

To configure the *Pulse Generator* resource as a PWM, refer to *Configuring Pulse Width Modulation* (see *Modicon M221, Logic Controller, Programming Guide*).

Properties

The *Pulse Width Modulation* function block has the following properties:

Property	Value	Description
Used	Activated / deactivated checkbox	Indicates whether the address is in use.
Address	%PWMi where <i>i</i> is 0 or 1	<i>i</i> is the instance identifier. For the maximum number of <i>PWM</i> objects, refer to the table <i>Maximum Number of Objects</i> (see <i>Modicon M221, Logic Controller, Programming Guide</i>).
Symbol	User-defined text	The symbol associated with this object. For details, refer to <i>Defining and Using Symbols</i> (see <i>EcoStruxure Machine Expert - Basic, Operating Guide</i>).
Preset	<ul style="list-style-type: none"> • %PWMi.P=1 if Time Base=1 s • $1 \leq \%PWMi.P \leq 100$ if Time Base=10 ms • $1 \leq \%PWMi.P \leq 1000$ if Time Base=1 ms • $1 \leq \%PWMi.P \leq 10000$ if Time Base=0.1 ms 	Preselection of the period
Duty cycle	From 0 to 100 NOTE: Values greater than 100 are considered to be equal to 100.	The Duty cycle is controlled by the object %PWMi.R, and is the percentage of the signal in state 1 within the period. The width of state 1 (<i>Tp</i>) is thus equal to: $TP = T \times (\%PWMi.R/100)$. The user application writes the value for %PWMi.R.
Comment	User-defined text	A comment to associate with this object.

NOTE: The **Num.Pulse**, **Current** and **Done** properties that appear in the **Pulse Generators properties** table under the **Programming** tab do not apply to the PWM function.

Objects

The *Pulse Width Modulation* function block is associated with the following objects:

Object	Description	Size (bit)	Default Value	Range	
%PwMi.P	Preset value	16	Preset (set on Configuration > Pulse Generators)	Preset %PwMi.P	Time Base
				1...10000	0.1 ms
				1...1000	1 ms
				1...100	10 ms
				1	1 s (default)
%PwMi.R	Duty cycle (<i>Ratio</i>)	16	0	0...100	

If %PwMi.P is:

- modified, the output signal period is affected at the end of the ongoing period.
- set to 0, the pulse generation function is stopped.
- out of range, the parameter is forced to 0 and the pulse generation function is stopped.

If %PwMi.R is:

- set to 0, the pulse generation function is stopped (output set to 0).
- set to 100, the output signal is set to 1
- changed, the output signal ratio is changed at the end of the current period.
- out of range, the parameter is forced to 0.

Time Base

The **Time Base** is set in the menu **Configuration > Pulse Generators** and can only be modified under the **Configuration** tab. For more details, refer to *Configuring Pulse Generators* (see Modicon M221, Logic Controller, Programming Guide).

The output signal period *T* is set with **Preset** and the **Time Base** parameters such that $T = \%PwMi.P \times \text{Time Base}$.

This table presents the range of available periods:

Time Base	Frequency Range
0.1 ms	1 Hz...10000 Hz
1 ms	1 Hz...1000 Hz
10 ms	1 Hz...100 Hz
1 s	1 Hz...1 Hz

Timing Diagram

This diagram presents the timing for the *Pulse Width Modulation* function block:

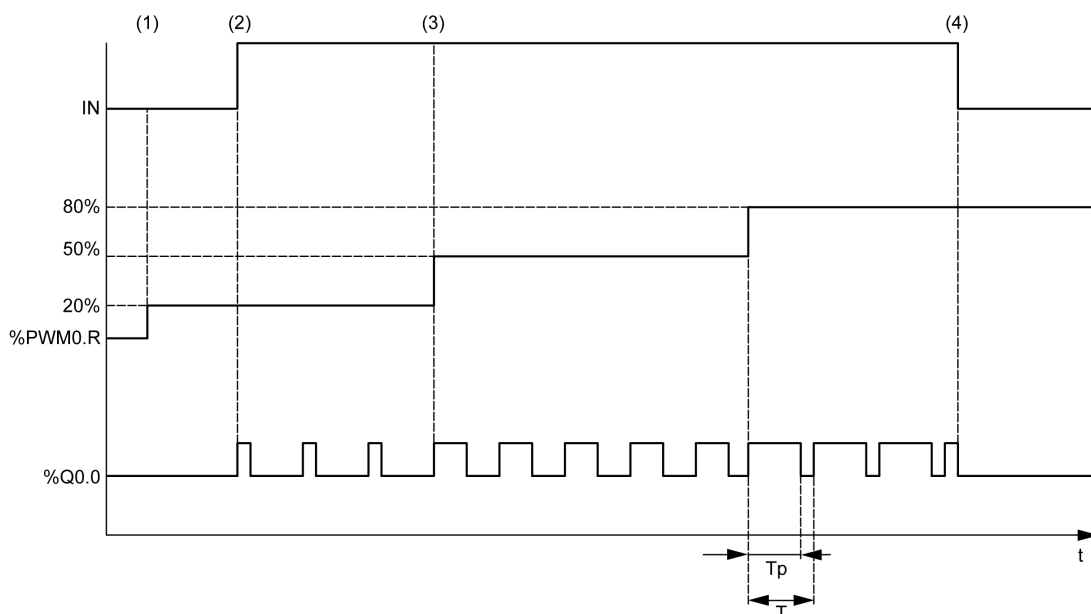

- (1) The PWM ratio ($\%PWMi.R$) is set to 20%, $IN = 0$ so the pulse generation is not active
- (2) IN is set to 1 so PWM output is activated
- (3) The programmable width (Tp) changes with $\%PWM.R$
- (4) IN is set to 0 so the PWM function is inhibited

Special Cases

Special Case	Description
Effect of cold restart ($\%S0=TRUE$)	<ul style="list-style-type: none"> • Pulse generation is stopped. • During the controller initialization, output is reset to 0. • If after the controller initialization: <ul style="list-style-type: none"> ◦ the controller enters the <i>STOPPED</i> state, the configured fallback strategy is applied to the output. ◦ the controller enters the <i>RUNNING</i> state, the configuration parameters are restored.
Effect of warm restart ($\%S1=TRUE$)	<ul style="list-style-type: none"> • Pulse generation is stopped. • During the controller initialization, output is reset to 0. • If after controller initialization, it enters the <i>STOPPED</i> state, the configured fallback strategy is applied to the output.
Effect at controller stop	<ul style="list-style-type: none"> • Pulse generation is stopped. • The fallback behavior depends on the configured fallback strategy: <ul style="list-style-type: none"> ◦ Maintain value: the outputs are reset to 0. ◦ Fallback value: the outputs are set to the fallback configured values (see EcoStruxure Machine Expert - Basic, Operating Guide).
Effect of online modification	None

Programming Example

Introduction

The *Pulse Width Modulation* function block can be configured as in this programming example.

Programming Example

In this example:

- The signal width is modified by the program according to the state of controller input *%I0.0* and *%I0.1*.
- The time base is set to 10 ms.
- The preset value *%PWM0.P* is set to 50 so the ratio step is equal to 2%.
- The configurable period T is equal to 500 ms.

The result is:

- If *%I0.0* and *%I0.1* are set to 0, the *%PWM0.R* ratio is set at 20%, the duration of the signal at state 1 is then: 20% x 500 ms = 100 ms.
- If *%I0.0* is set to 1 and *%I0.1* is set to 0, the *%PWM0.R* ratio is set at 50% (duration 250 ms).
- If *%I0.0* and *%I0.1* are set to 1, the *%PWM0.R* ratio is set at 80% (duration 400 ms).

Examples of *Pulse Width Modulation* instructions:

Rung	Instruction
0	LDN %I0.0 ANDN %I0.1 [%PWM0.R:=20]
1	LD %I0.0 ANDN %I0.1 [%PWM0.R:=50]
2	LD %I0.0 AND %I0.1 [%PWM0.R:=80]
3	BLK %PWM0 LD %I0.2 IN END_BLK

NOTE: Refer to the reversibility procedure (see EcoStruxure Machine Expert - Basic, Generic Functions Library Guide) to obtain the equivalent Ladder Diagram.

Drive (%DRV)

What's in This Chapter

Description	52
Drive and Logic Controller States	54
Adding a Drive Function Block.....	56
Function Block Configuration.....	57
MC_Power_ATV: Enable/Disable Power Stage.....	57
MC_Jog_ATV: Start Jog Mode	59
MC_MoveVel_ATV: Move at Specified Velocity.....	62
MC_Stop_ATV: Stop Movement	64
MC_ReadStatus_ATV: Read Device Status.....	66
MC_ReadMotionState_ATV: Read Motion State	68
MC_Reset_ATV: Acknowledge and Reset Error.....	70
Error Codes	72

Description

Presentation

Drive function blocks  allow drive devices such as Altivar Speed Drives to be controlled by an M221 Logic Controller. For example:

- Control the speed of a motor managed by an ATV drive and update it continuously
- Monitor the status of the ATV drive and motor
- Manage errors detected in the ATV drive.

Communications take place over one of the following methods:

- Configuring one of the serial lines of the logic controller as a Modbus Serial IOScanner (see Modicon M221, Logic Controller, Programming Guide) using the Modbus RTU protocol.
- Configuring the Ethernet port as a Modbus TCP IOScanner.

In EcoStruxure Machine Expert - Basic, first add targeted ATV drive types to the Modbus Serial IOScanner or Modbus TCP IOScanner. This sets up predefined channels and initialization requests allowing data to be read from and written to specific registers on the ATV drive, including for example:

- **ETA** Status Word
- **ETI** Extended Status Word
- **RFRD** Output Velocity (RPM)
- **DP0** Error Code on Last Error
- **CMD** Control Word

Data transfer is carried out using Modbus request type **FC23 - Read/Write Multiple Registers**. This allows the program, for example, to read from the **ETA**, **ETI**, and **DP0** registers and write to the **CMD** register with a single Modbus request.

The following single-axis Drive function blocks are available in the **Programming** tab of EcoStruxure Machine Expert - Basic:

Function Block	Description
MC_Power_ATV, page 57	Enables or disables the power stage of a device.
MC_Jog_ATV, page 59	Starts the Jog operating mode on a device.
MC_MoveVel_ATV, page 62	Specifies a target velocity for a device.
MC_Stop_ATV, page 64	Stops the current movement on a device.
MC_ReadStatus_ATV, page 66	Returns status information about a device.
MC_ReadMotionState_ATV, page 68	Returns status information on the current movement of a device.
MC_Reset_ATV, page 70	Reset device error regarding the drive state, page 54 and acknowledge MC_Power_ATV, page 57 errors.

A maximum of 16 instances of each Drive function block can be used in a program at any one time.

When a device is added to the Modbus Serial IOScanner or Modbus TCP IOScanner, EcoStruxure Machine Expert - Basic allocates an axis for the device using a `%DRVn` object, where *n* is the number of the ATV drive. Each time you add a Drive function block to your program, you must associate it with an axis, creating a link between the function block, the axis, and the target device defined in the Modbus Serial IOScanner or Modbus TCP IOScanner.

Drive and Logic Controller States

Drive State Diagram

The drive is always in one of the states defined in the diagram below. When a Drive function block is executed or an error occurs, this may cause a state transition:

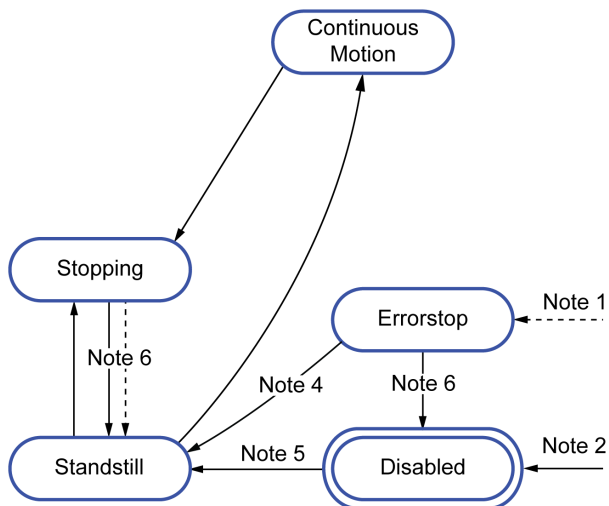

Note 1 From any state if an error occurs.

Note 2 From any state (if no *ErrorAxis*) when *%MC_Power_ATV.status* is 0.

Note 3 Transition from *ErrorStop* to *Disabled* state only if *%MC_Reset_ATV.Done* = 1 and *%MC_Power_ATV.status* = 0.

Note 4 Transition from *ErrorStop* to *Standstill* state only if *%MC_Reset_ATV.Done* = 1 and *%MC_Power_ATV.Enable* = 1 and *%MC_Power_ATV.Status* = 1.

Note 5 Transition from *DISABLED* to *Standstill* state only if *%MC_Power_ATV.Enable* = 1 and *%MC_Power_ATV.Status* = 1.

Note 6 Transition from *Stopping* to *Standstill* state only if *%MC_Stop_ATV.Done* = 1 and *%MC_Stop_ATV.Execute* = 0.

This table describes the drive states:

State	Description
<i>Disabled</i>	Initial state. The drive is not in an operational status or in an error status.
<i>Standstill</i>	The drive is in an operational status (ETA = 16#xx37) and <i>Velocity</i> = 0 (RFRD = 0).
<i>ErrorStop</i>	The drive is in an error status (ETA = 16#xxx8)
<i>Continuous motion</i>	The drive is in an operational status (ETA = 16#xx37) and <i>Velocity</i> ≠ 0 (RFRD ≠ 0).
<i>Stopping</i>	<i>MC_Stop_ATV</i> function block is executing.

The function block *MC_ReadStatus_ATV*, page 66 can be used to read the status of the ATV drive.

Logic Controller State Transitions

The following table describes how the Drive function blocks are affected by changes in the logic controller state:

Logic Controller State	Impact on Drive Function Blocks
<i>RUNNING</i>	Drive function blocks are executed normally according to the user logic.
<i>STOPPED</i>	The configured drive axes are stopped when the controller goes into the <i>STOPPED</i> state, unless the Fallback Behavior option is set to Maintain values . If the Fallback Behavior option is set to Fallback values , the command 0x00 is sent to the ATV drive, which leads to a Switch on Disabled (NST) status. Otherwise, if Fallback Behavior is set to Maintain values , no action is taken (the command is not changed).
<i>HALTED</i>	The configured drive axes are stopped when the controller goes into the <i>HALTED</i> state, unless the Fallback Behavior option is set to Maintain values . If the Fallback Behavior option is set to Fallback values , the command 0x00 is sent to the ATV drive, which leads to a Switch on Disabled (NST) status. Otherwise, if Fallback Behavior is set to Maintain values , no action is taken (the command is not changed).
<i>POWERLESS, EMPTY</i>	Drive function blocks are not executed (the Modbus Serial IOScanner or Modbus TCP IOScanner is stopped). This is also the case when the application in the controller is updated.

NOTE: In the case of the controller state of *HALTED* or *STOPPED*, and you have selected to **Maintain values**, the drive is not given any further commands by the controller. Therefore, the drive must determine the appropriate state to assume. If you chose to **Maintain values** for the drive, you must include this in your hazard and risk analysis for any consequential and possibly hazardous events.

▲ WARNING
UNINTENDED EQUIPMENT OPERATION
Ensure that a risk assessment is conducted and respected according to EN/ISO 12100 during the design of your machine.
Failure to follow these instructions can result in death, serious injury, or equipment damage.

Adding a Drive Function Block

Prerequisites

Prerequisites to add a Drive function block:

- A Modbus Serial IOScanner or Modbus TCP IOScanner must be configured on a serial line or on Ethernet.
- The ATV drives to be controlled must be added and configured (see Modicon M221, Logic Controller, Programming Guide) on the Modbus Serial IOScanner or Modbus TCP IOScanner .

Adding a Drive Function Block

Follow these steps to add an instance of a Drive function block:

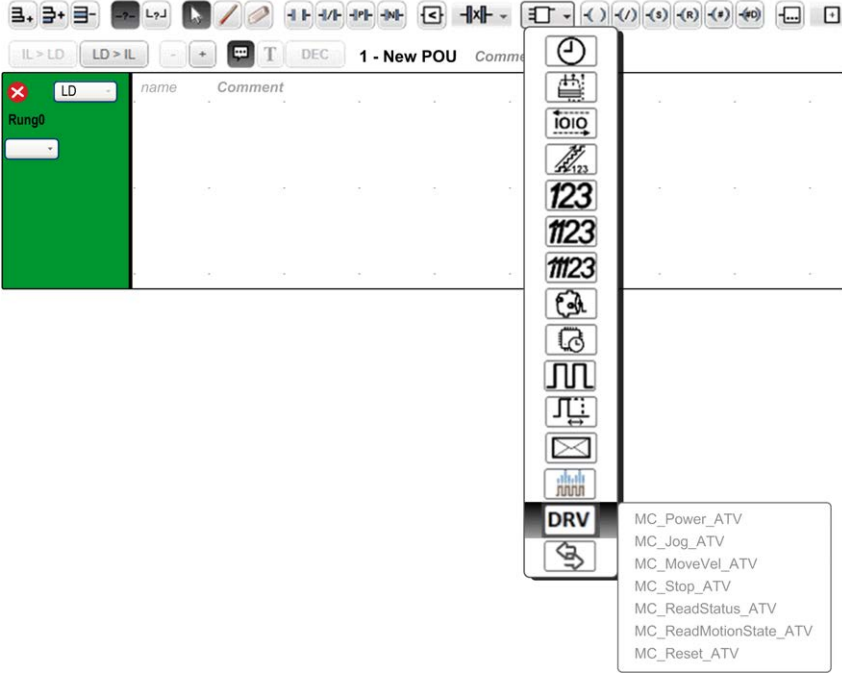
Step	Action
1	Select the Programming tab.
2	Select Function Blocks > Drive as shown in the following graphic: 
3	Click into the rung to place the selected function block.
4	Associate the inputs/outputs of the function block.

Removing a Function Block

Follow these steps to remove an instance of a Drive function block:

Step	Action
1	In the Programming tab, click the instance of the function block.
2	Press Delete to remove the selected function block.

Function Block Configuration

Configuring Drive Objects

Each Drive function block is associated with a Drive (%DRV) object. To display a list of configured Drive objects:

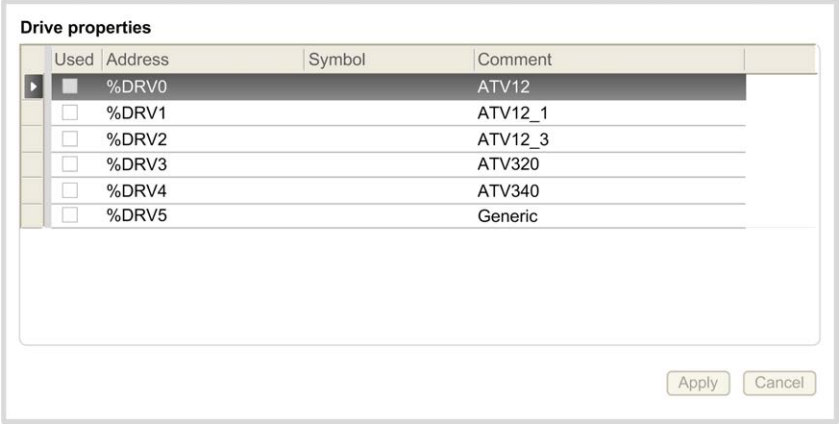
Step	Action
1	<p>Select the Programming > Tools tab and click Drive objects > Drive to display Drive object properties.</p> 
2	Update the properties as required and click Apply

Drive function blocks have the following properties:

Parameter	Editable	Value	Default Value	Description
Used	No	True/False	False	Indicates whether the Drive object is in use in the program.
Address	No	%DRVn	%DRVn	The address of the Drive object, where n is the object number.
Symbol	Yes	–	–	Allows you to specify a symbol to associate with the Drive object. Double-click the cell to define or edit a symbol.
Comment	Yes	–	–	Allows you to specify a comment to associate with the Drive object. Double-click the cell to define or edit a comment.

MC_Power_ATV: Enable/Disable Power Stage

Description

This function block enables or disables the drive power stage.

A rising edge of the input *Enable* enables the power stage. When the power stage is enabled, the output *Status* is set to 1.

A falling edge of the input *Enable* disables the power stage (*Shutdown* command without *Error*). When the power stage is disabled, the output *Status* is reset to 0.

If the internal status register ETA of the ATV drive has not reached an operational status before the expiration of the timeout value, a *Timeout Error* is generated. The timeout is calculated as the channel cycle time multiplied by 4, or 10 seconds,

whichever is greater. A minimum of 10 seconds is required to allow for drive reaction time.

If errors are detected during execution of the function block, the output *Error* is set to 1. This leads to a Shutdown command (CMD = 16#0006) to disable the ATV drive (Ready to switch on status, ETA = 16#xx21).

If an error occurs, only a successful execution of MC_Reset_ATV, page 70 function block can restore the power stage.

Graphical Representation

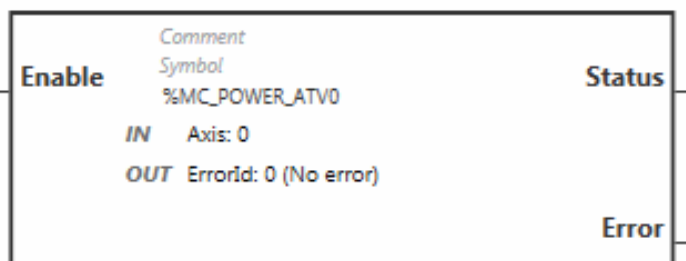

Inputs

This table describes the inputs of the function block:

Label	Object	Initial value	Description
<i>Enable</i>	-	0	Set to 1 to start execution of the function block and enable the power stage. Set to 0 to stop execution of the function block and disable the power stage.
<i>Axis</i>	%MC_POWER_ATVi.AXIS where i is 0...15	-	Identifier of the axis (%DRV0...%DRV15) for which the function block is to be executed.

Outputs

This table describes the outputs of the function block:

Label	Object	Initial value	Value
<i>Status</i>	%MC_POWER_ATVi.STATUS where i is 0...15	0	Default value: 0 <ul style="list-style-type: none"> 0: Power stage is disabled. 1: Power stage is enabled. Set to 1 when the ATV drive reaches an operational status (ETA = 16#xx37)
<i>Error</i>	%MC_POWER_ATVi.ERROR where i is 0...15	0	Set to 0 when no error is detected. Set to 1 if an error occurs during execution. Function block execution is finished. The <i>ErrorId</i> output object indicates the cause of the error.
<i>ErrorId</i>	%MC_POWER_ATVi.ERRORID where i is 0...15	0 (No error)	Error code returned by the function block when the <i>Error</i> output is set to 1. For details on the errors, refer to Error Codes, page 72. Range: 0...65535

Parameters

Double-click the function block to display the function block parameters.

The *MC_Power_ATV* function block has the following parameters:

Parameter	Value	Description
Used	Address used	If selected, this address is currently in use in a program.
Address	<i>%MC_Power_ATVi</i>	The instance identifier, where i is from 0 to the number of objects available on this logic controller. For the maximum number of Drive objects, refer to the table Maximum Number of Objects (see Modicon M221, Logic Controller, Programming Guide).
Symbol	Symbol	The symbol associated with this object. For details, refer to Defining and Using Symbols (see EcoStruxure Machine Expert - Basic, Operating Guide).
Axis	<i>%DRVn</i> , where n is 0...15 None	Select the axis (Drive object instance) for which the function block is to be executed. The Drive object must have been previously configured on the Modbus TCP IOScanner or Modbus Serial IOScanner (see Modicon M221, Logic Controller, Programming Guide).
Comment	Comment	An optional comment can be associated with this object. Double-click in the Comment column and type a comment.

Update the parameters as required and click **Apply**.

MC_Jog_ATV: Start Jog Mode

Description

This function block starts the Jog operating mode. A Jog operation commands a device to move forwards or backwards at a specified velocity.

If either of the function blocks *MC_MoveVel_ATV*, page 62 or *MC_Stop_ATV*, page 64 is enabled while this function block is executing (*Busy* output set to 1), the *MC_Jog_ATV* function block commands the movement. The *Busy* output is reset to 0 and the *CmdAborted* output is set to 1.

When a Jog operation is in progress, a change of velocity value (*Vel*) is only applied on detection of a falling/rising edge of the *Forward* or *Backward* inputs.

If either of the *Error* or *CmdAborted* outputs is set to 1, the *Forward* and *Backward* inputs must first be reset to 0 and then a new rising edge applied to the *Forward* and/or *Backward* inputs to restart the movement.

Starting a Jog operation while the *MC_Stop_ATV*, page 64 function block is executing causes a Stop Active Error. Starting a Jog operation when the drive is not in an operational status (ETA ≠ 16#xx37) causes a Not Run Error.

Graphical Representation

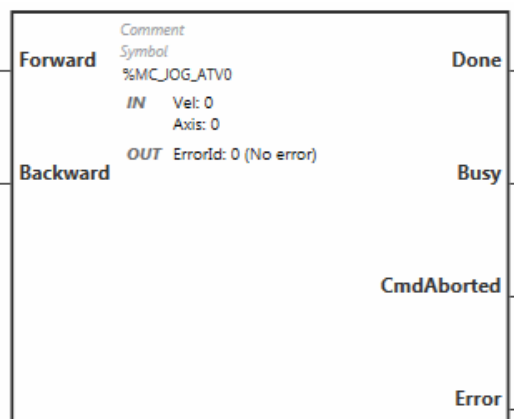

Inputs

This table describes the inputs of the function block:

Input	Object	Initial Value	Description
<i>Forward</i>	-	0	Setting either the <i>Forward</i> input or the <i>Backward</i> input to 1 starts the jog movement. If the <i>Forward</i> and <i>Backward</i> inputs are both set to 1, the operating mode remains active, the jog movement is stopped, and the <i>Busy</i> output remains set to 1. If the <i>Forward</i> and <i>Backward</i> inputs are both set to 0, the operating mode is terminated and the <i>Done</i> output is set to 1 for one cycle.
<i>Backward</i>	-	0	
<i>Vel</i>	%MC_JOG_ATVi.VEL where i is 0...15	0	Target velocity for the Jog operating mode, in revolutions per minute (rpm). During jog movement, a change in the velocity value <i>Vel</i> is only applied upon detection of a falling/rising edge of the <i>Forward</i> or <i>Backward</i> input. Range: -32768...32767
<i>Axis</i>	%MC_JOG_ATVi.AXIS where i is 0...15	-	Identifier of the axis (%DRV0...%DRV15) for which the function block is to be executed. The axis must first be declared in the Configuration tab.

Outputs

This table describes the outputs of the function block:

Output	Output Object	Initial Value	Description
<i>Done</i>	%MC_JOG_ATVi.DONE	0	Set to 1 for one cycle when both the <i>Forward</i> and <i>Backward</i> inputs are set to 0. Set to 1 to indicate that the Jog operating mode is terminated.
<i>Busy</i>	%MC_JOG_ATVi.BUSY	0	Set to 1 when: <ul style="list-style-type: none"> • <i>Jog</i> is in progress (<i>Forward</i> = 1 or <i>Backward</i> = 1 • Both the <i>Forward</i> and <i>Backward</i> inputs are set to 1, indicating that the Jog operating mode remains active and the jog movement is stopped.
<i>CmdAborted</i>	%MC_JOG_ATVi.CMDABORTED	0	Set to 1 if function block execution terminates due to another command being executed.
<i>Error</i>	%MC_JOG_ATVi.ERROR	0	Set to 0 when no error is detected. Set to 1 if an error occurs during execution. Function block execution is finished. The <i>ErrorId</i> output object indicates the cause of the error.
<i>ErrorId</i>	%MC_JOG_ATVi.ERRORID	0 (No error)	Error code returned by the function block when the <i>Error</i> output is set to 1. For details on the errors, refer to <i>Error Codes</i> , page 72. Range: 0...65535

Parameters

Double-click the function block to display the function block parameters.

The *MC_Jog_ATV* function block has the following parameters:

Parameter	Value	Description
Used	Address used	If selected, this address is currently in use in a program.
Address	%MC_Jog_ATVi	The instance identifier, where <i>i</i> is from 0 to the number of objects available on this logic controller. For the maximum number of Drive objects, refer to the table Maximum Number of Objects (see Modicon M221, Logic Controller, Programming Guide).
Symbol	Symbol	The symbol associated with this object. For details, refer to <i>Defining and Using Symbols</i> (see <i>EcoStruxure Machine Expert - Basic, Operating Guide</i>).
Axis	%DRV <i>n</i> , where <i>n</i> is 0...15 None	Select the axis (Drive object instance) for which the function block is to be executed. The Drive object must have been previously configured on the Modbus TCP I/O Scanner or Modbus Serial I/O Scanner (see Modicon M221, Logic Controller, Programming Guide).
Vel	Target velocity	Enter the target velocity for the Jog operating mode and press Enter. Default value: 0 Range: -32768...32767
Comment	Comment	An optional comment can be associated with this object. Double-click in the Comment column and type a comment.

Update the parameters as required and click **Apply**.

MC_MoveVel_ATV: Move at Specified Velocity

Description

This function block starts the Profile Velocity operating mode with a specified velocity. When the target velocity is reached, the *InVel* output is set to 1.

If the *MC_Jog_ATV*, page 59 or *MC_Stop_ATV*, page 64 function blocks are enabled while this function block is executing (*Busy* output set to 1), *MC_MoveVel_ATV* commands the movement. In this case, the *Busy* output is reset to 0 and the *CmdAborted* output is set to 1.

The *ContUpdate* and *Vel* input values are applied on a rising edge of the *Execute* input.

If either of the *Error* or *CmdAborted* outputs of *MC_MoveVel_ATV* is set to 1, a new rising edge of *Execute* is necessary to resume the movement.

Starting this function block while the *MC_Stop_ATV*, page 64 function block is executing leads to a Stop Active Error.

Starting this function block when the drive is not in an operational status (ETA ≠ 16#xx37), leads to a Not Run Error.

Graphical Representation

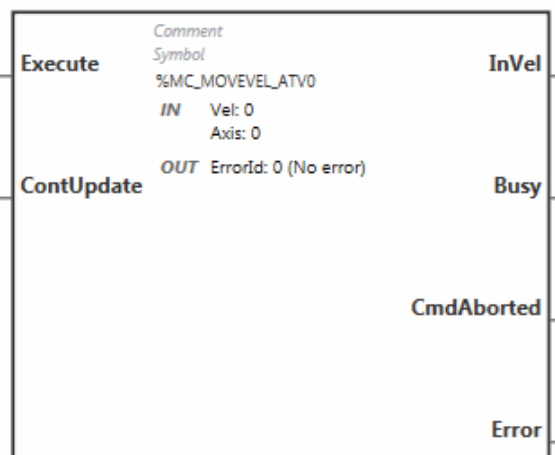

Inputs

This table describes the inputs of the function block:

Input	Object	Initial Value	Description
<i>Execute</i>	-	0	Set to 1 to start execution of the function block.
<i>ContUpdate</i>	-	0	Set to 1 before executing the function block to enable continuous updating of the <i>Vel</i> parameter value.
<i>Vel</i>	%MC_MOVEVEL_ATVi.VEL where i is 0...15	0	Target velocity for the operating mode, in units of revolutions per minute (rpm). Range: -32 768...32 767. A negative value forces movement in the opposite direction.
<i>Axis</i>	%MC_MOVEVEL_ATVi.AXIS where i is 0...15	-	Identifier of the axis (%DRV0...%DRV15) for which the function block is to be executed. The axis must first be declared in the Configuration tab.

Outputs

This table describes the outputs of the function block:

Output	Object	Initial Value	Description
<i>InVel</i>		0	0 indicates that the target velocity (<i>Vel</i>) has not been reached. Set to 1 when the target velocity (<i>Vel</i>) is reached.
<i>Busy</i>	<code>%MC_MOVEVEL_ATVi.BUSY</code>	0	Set to 1 when the function block is executed. Remains at 1 even after the target velocity is reached. Reset to 0 when the function block is stopped or aborted.
<i>CmdAborted</i>	<code>%MC_MOVEVEL_ATVi.CMDABORTED</code>	0	Set to 1 if function block execution is terminated due to another command being executed.
<i>Error</i>	<code>%MC_MOVEVEL_ATVi.ERROR</code>	0	Set to 0 when no error is detected. Set to 1 if an error occurs during execution. Function block execution is finished. The <i>ErrorId</i> output object indicates the cause of the error.
<i>ErrorId</i>	<code>%MC_MOVEVEL_ATVi.ERRORID</code>	0 (No error)	Error code returned by the function block when the <i>Error</i> output is set to 1. For details on the errors, refer to Error Codes, page 72. Range: 0...65535

NOTE: When the speed command of the ATV drive is low (< 10), the *InVel* and *ConstantVel* parameters may be invalid because the speed range of the ATV drive itself may be inaccurate.

Parameters

Double-click the function block to display the function block parameters.

The *MC_MoveVel_ATV* function block has the following parameters:

Parameter	Value	Description
Used	Address used	If selected, this address is currently in use in a program.
Address	<code>%MC_MoveVel_ATVi</code>	The instance identifier, where <i>i</i> is from 0 to the number of objects available on this logic controller. For the maximum number of Drive objects, refer to the table Maximum Number of Objects (see Modicon M221, Logic Controller, Programming Guide).
Symbol	Symbol	The symbol associated with this object. For details, refer to Defining and Using Symbols (see EcoStruxure Machine Expert - Basic, Operating Guide).
Axis	<code>%DRVn</code> , where <i>n</i> is 0...15 None	Select the axis (Drive object instance) for which the function block is to be executed. The Drive object must have been previously configured on the Modbus TCP IOScanner or Modbus Serial IOScanner (see Modicon M221, Logic Controller, Programming Guide).
Vel	Target velocity	Enter the target velocity for the operating mode and press Enter. Default value: 0 Range: -32768...32767. A negative value forces movement in the opposite direction.
Comment	Comment	An optional comment can be associated with this object. Double-click in the Comment column and type a comment.

Update the parameters as required and click **Apply**.

MC_Stop_ATV: Stop Movement

Description

This function block stops the ongoing movement of the specified drive.

Drive-specific stop parameters, for example deceleration, are provided by the configuration of the drive.

Once started by a rising edge on the *Execute* input, any further activity on the *Execute* input is ignored until *Done* is set to TRUE. Executing another Drive function block while *MC_Stop_ATV* is busy does not abort the stop procedure—the function block *MC_Stop_ATV* remains busy and the other function block ends in an error.

The stop procedure can only be interrupted by disabling the power stage or if an error occurs (for example, ATV Not Run error or Modbus TCP IScanner or Modbus Serial IScanner error).

Graphical Representation



Inputs

This table describes the inputs of the function block:

Input	Object	Initial Value	Description
<i>Execute</i>	-	0	Set to 1 to start execution of the function block. The execution of other motion function block is not possible when the <i>Busy</i> output is set to 1. In this case, the other function block returns an error.
<i>Axis</i>	%MC_STOP_ATVi.AXIS where i is 0...15	-	Identifier of the axis (%DRV0...%DRV15) for which the function block is to be executed.

Outputs

This table describes the outputs of the function block:

Output	Output Object	Initial Value	Description
<i>Done</i>	<i>%MC_STOP_ATVi.DONE</i>	0	Set to 1 to indicate the function block execution is complete.
<i>Busy</i>	<i>%MC_STOP_ATVi.BUSY</i>	0	Set to 1 when function block execution begins.
<i>Error</i>	<i>%MC_STOP_ATVi.ERROR</i>	0	Set to 0 when no error is detected. Set to 1 if an error occurs during execution. Function block execution is finished. The <i>ErrorId</i> output object indicates the cause of the error.
<i>ErrorId</i>	<i>%MC_STOP_ATVi.ERRORID</i>	0 (No error)	Error code returned by the function block when the <i>Error</i> output is set to 1. For details on the errors, refer to Error Codes, page 72. Range: 0...65535

Parameters

Double-click the function block to display the function block parameters.

The *MC_Stop_ATV* function block has the following parameters:

Parameter	Value	Description
Used	Address used	If selected, this address is currently in use in a program.
Address	<i>%MC_Stop_ATVi</i>	The instance identifier, where i is from 0 to the number of objects available on this logic controller. For the maximum number of Drive objects, refer to the table Maximum Number of Objects (see Modicon M221, Logic Controller, Programming Guide).
Symbol	Symbol	The symbol associated with this object. For details, refer to Defining and Using Symbols (see EcoStruxure Machine Expert - Basic, Operating Guide).
Axis	<i>%DRVn</i> , where n is 0...15 None	Select the axis (Drive object instance) for which the function block is to be executed. The Drive object must have been previously configured on the Modbus TCP IOScanner or Modbus Serial IOScanner (see Modicon M221, Logic Controller, Programming Guide).
Comment	Comment	An optional comment can be associated with this object. Double-click in the Comment column and type a comment.

Update the parameters as required and click **Apply**.

MC_ReadStatus_ATV: Read Device Status

Description

The function block reads the status of the ATV drive.
 Refer to Drive State Diagram, page 54 for details on the states.

Graphical Representation

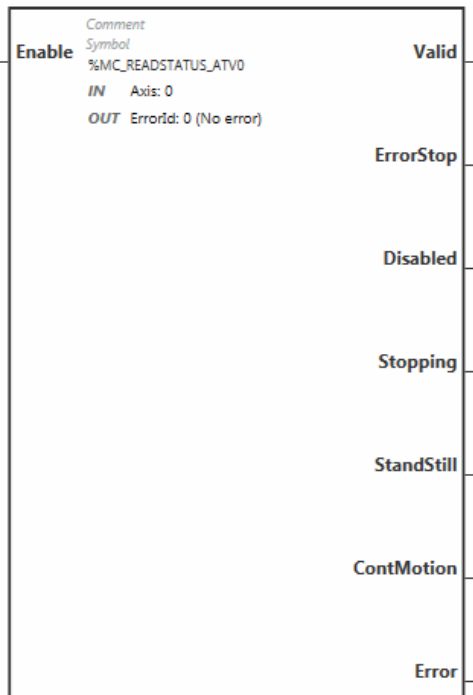

Inputs

This table describes the inputs of the function block:

Label	Object	Initial value	Description
Enable	-	0	Set to 1 to enable the function block.
Axis	%MC_READSTATUS_ATVi. AXIS where i is 0...15	-	Identifier of the axis (%DRV0...%DRV15) for which the function block is to be executed.

Outputs

This table describes the outputs of the function block:

Label	Object	Initial value	Description
<i>Valid</i>	%MC_READSTATUS_ATVi. VALID	0	Set to 1 while the function block is running without errors.
<i>ErrorStop</i>	%MC_READSTATUS_ATVi. ERRORSTOP	0	Set to 1 if the ATV drive is in an error status (ETA = 16#xxx8).
<i>Disabled</i>	%MC_READSTATUS_ATVi. DISABLED	0	Set to 1 if the ATV drive is not in an operational status and not in an error status.
<i>Stopping</i>	%MC_READSTATUS_ATVi. STOPPING	0	Set to 1 if the MC_Stop_ATV function block is being executed, or the movement is being stopped.
<i>Standstill</i>	%MC_READSTATUS_ATVi. STANDSTILL	0	Set to 1 if the ATV drive is in an operational status and the velocity is 0 (ETA = 16#xx37 and RFRD = 0).
<i>ContMotion</i>	%MC_READSTATUS_ATVi. CONTMOTION	0	Set to 1 if the ATV drive is in an operational status and the velocity is not equal to 0 (ETA = 16#xx37 and RFRD ≠ 0).
<i>Error</i>	%MC_READSTATUS_ATVi. ERROR	0	Set to 0 when no error is detected. Set to 1 if an error occurs during execution. Function block execution is finished. The <i>ErrorId</i> output object indicates the cause of the error.
<i>ErrorId</i>	%MC_READSTATUS_ATVi. ERRORID	0 (No error)	Error code returned by the function block when the <i>Error</i> output is set to 1. For details on the errors, refer to Error Codes, page 72. Range: 0...65535

Parameters

Double-click the function block to display the function block parameters.

The *MC_ReadStatus_ATV* function block has the following parameters:

Parameter	Value	Description
Used	Address used	If selected, this address is currently in use in a program.
Address	%MC_ReadStatus_ATVi	The instance identifier, where i is from 0 to the number of objects available on this logic controller. For the maximum number of Drive objects, refer to the table Maximum Number of Objects (see Modicon M221, Logic Controller, Programming Guide).
Symbol	Symbol	The symbol associated with this object. For details, refer to Defining and Using Symbols (see EcoStruxure Machine Expert - Basic, Operating Guide).
Axis	%DRVn, where n is 0...15 None	Select the axis (Drive object instance) for which the function block is to be executed. The Drive object must have been previously configured on the Modbus TCP IOScanner or Modbus Serial IOScanner (see Modicon M221, Logic Controller, Programming Guide).
Comment	Comment	An optional comment can be associated with this object. Double-click in the Comment column and type a comment.

Update the parameters as required and click **Apply**.

MC_ReadMotionState_ATV: Read Motion State

Description

This function block outputs status information on the movement read from the ATV drive.

Graphical Representation

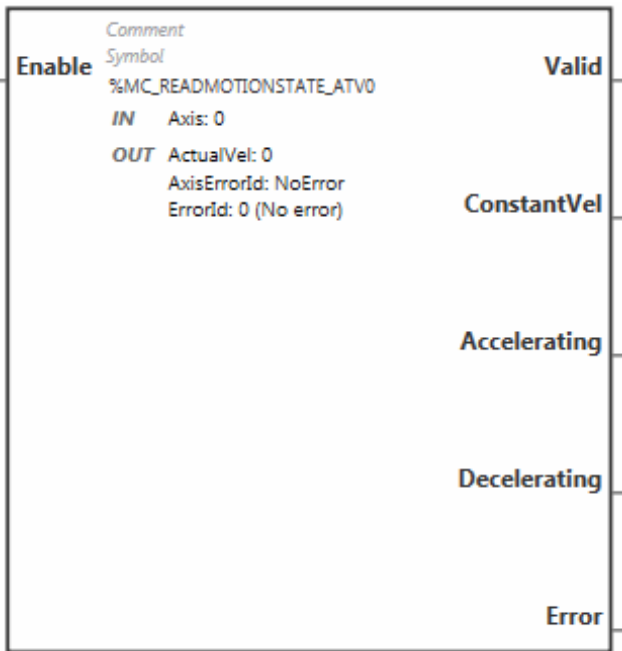

Inputs

This table describes the inputs of the function block:

Input	Object	Initial Value	Description
Enable	-	0	Set to 1 to start execution of the function block.
Axis	%MC_READMOTIONSTATE_ATVi. AXIS where i is 0...15	-	Identifier of the axis (%DRV0...%DRV15) for which the function block is to be executed.

Outputs

This table describes the outputs of the function block:

Output	Object	Initial Value	Description
<i>Valid</i>	%MC_READMOTIONSTATE_ATVi.VALID	0	Set to 1 while the function block is running without errors.
<i>ConstantVel</i>	%MC_READMOTIONSTATE_ATVi.CONSTANTVEL	0	Set to 1 when a movement at constant velocity is being performed (ETA register).
<i>Accelerating</i>	%MC_READMOTIONSTATE_ATVi.ACCELERATING	0	Set to 1 when the motor is accelerating (ETI register).
<i>Decelerating</i>	%MC_READMOTIONSTATE_ATVi.DECELERATING	0	Set to 1 when the motor is decelerating (ETI register).
<i>Error</i>	%MC_READMOTIONSTATE_ATVi.ERROR	0	Set to 0 when no error is detected. Set to 1 if an error occurs during execution. Function block execution is finished. The <i>ErrorId</i> output object indicates the cause of the error.
<i>ActualVel</i>	%MC_READMOTIONSTATE_ATVi.ACTUALVEL	0	Velocity returned by the ATV drive (RFRD register). Range: -32768...32767
<i>AxisErrorId</i>	%MC_READMOTIONSTATE_ATVi.AXISERRORID	0	Axis error identifier returned by the ATV drive (DP0 register). There is an axis error when the drive is in an error status. Set to 0 if the drive is not in an error status (ETA register ≠ 16#xxx8) For details on axis errors, refer to <i>AxisErrorId</i> Error Codes, page 72. Range: -32768...32767
<i>ErrorId</i>	%MC_READMOTIONSTATE_ATVi.ERRORID	No error (nOF)	Error code returned by the function block when the <i>Error</i> output is set to 1. For details on the errors, refer to <i>Error Codes</i> , page 72. Range: 0...65535

NOTE: When the speed command of the ATV drive is low (< 10), the *InVel* and *ConstantVel* parameters may be invalid because the speed range of the ATV drive itself may be inaccurate.

Parameters

Double-click the function block to display the function block parameters.

The *MC_ReadMotionState_ATV* function block has the following parameters:

Parameter	Value	Description
Used	Address used	If selected, this address is currently in use in a program.
Address	<i>%MC_ReadMotionState_ATVi</i>	The instance identifier, where i is from 0 to the number of objects available on this logic controller. For the maximum number of Drive objects, refer to the table Maximum Number of Objects (see Modicon M221, Logic Controller, Programming Guide).
Symbol	Symbol	The symbol associated with this object. For details, refer to Defining and Using Symbols (see EcoStruxure Machine Expert - Basic, Operating Guide).
Axis	<i>%DRVn</i> , where n is 0...15 None	Select the axis (Drive object instance) for which the function block is to be executed. The Drive object must have been previously configured on the Modbus TCP IOScanner or Modbus Serial IOScanner (see Modicon M221, Logic Controller, Programming Guide).
Comment	Comment	An optional comment can be associated with this object. Double-click in the Comment column and type a comment.

Update the parameters as required and click **Apply**.

MC_Reset_ATV: Acknowledge and Reset Error

Description

This function block is used to acknowledge an error and re-initialize the error condition on the drive. For more information, refer to Drive State Diagram, page 54.

Graphical Representation

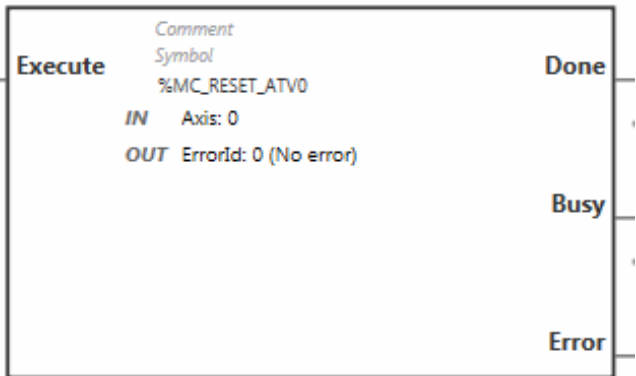

Inputs

This table describes the inputs of the function block:

Label	Object	Initial value	Description
<i>Execute</i>	-	0	Set to 1 to start execution of the function block.
<i>Axis</i>	%MC_RESET_ATVi.AXIS where i is 0...15	-	Identifier of the axis (%DRV0...%DRV15) for which the function block is to be executed.

Outputs

This table describes the outputs of the function block:

Output	Output Object	Initial Value	Description
<i>Done</i>	%MC_RESET_ATVi.DONE	0	Set to 1 when <i>Reset</i> has ended without error.
<i>Busy</i>	%MC_RESET_ATVi.BUSY	0	Set to 1 when the function block begins execution.
<i>Error</i>	%MC_RESET_ATVi.ERROR	0	Set to 1 if the device remains in an error status after timeout expiration. The timeout is calculated as the channel cycle time multiplied by 4, or 200 ms, whichever is greater. A minimum of 200 ms is required to allow for drive reaction time. Refer to Configuring Channels (see Modicon M221, Logic Controller, Programming Guide) for information on the configuring the channel cycle time.
<i>ErrorId</i>	%MC_RESET_ATVi.ERRORID	0 (No error)	Error code returned by the function block when the <i>Error</i> output is set to 1. For details on the errors, refer to Error Codes, page 72. Range: 0...65535

Parameters

Double-click the function block to display the function block parameters.

The *MC_Reset_ATV* function block has the following parameters:

Parameter	Value	Description
Used	Address used	If selected, this address is currently in use in a program.
Address	%MC_Reset_ATVi	The instance identifier, where i is from 0 to the number of objects available on this logic controller. For the maximum number of Drive objects, refer to the table Maximum Number of Objects (see Modicon M221, Logic Controller, Programming Guide).
Symbol	Symbol	The symbol associated with this object. For details, refer to Defining and Using Symbols (see EcoStruxure Machine Expert - Basic, Operating Guide).
Axis	%DRV n , where n is 0...15 None	Select the axis (Drive object instance) for which the function block is to be executed. The Drive object must have been previously configured on the Modbus TCP IOScanner or Modbus Serial IOScanner (see Modicon M221, Logic Controller, Programming Guide).
Comment	Comment	An optional comment can be associated with this object. Double-click in the Comment column and type a comment.

Update the parameters as required and click **Apply**.

Error Codes

ErrorId Error Codes

This table lists the possible function block error codes:

Value	Name	Description
0	No error	No error detected.
1	IOScanner error	Error detected on IOScanner ⁽¹⁾ .
2	ATV is in an error status	The ATV drive is in an error status (ETA = 16#xxx8).
3	Timeout error	Timeout expired before the <i>MC_Power_ATV</i> function block has received the correct status from the drive.
4	Invalid ATV status	The ATV drive has an invalid ETA value.
5	Reset error	The <i>MC_Reset_ATV</i> function block is requested while the ATV drive is in an error status.
6	Stop Active error	The <i>MC_Jog_ATV</i> or <i>MV_MoveVelocity_ATV</i> function block is requested while <i>MC_Stop</i> is active.
7	ATV Not Run error	The <i>MC_Jog_ATV</i> or <i>MV_MoveVelocity_ATV</i> function block is requested while the ATV drive is not operational.
8	Invalid AxisRef error	<i>AxisRef</i> input %DRV of the function block is invalid (not present in the Modbus TCP IOScanner or Modbus Serial IOScanner configuration (see Modicon M221, Logic Controller, Programming Guide)).
9	Internal error	A firmware error occurred.

⁽¹⁾ Only for Modbus TCP IOScanner.

If the *%MC_Power_ATV* function block raises an IOScanner error while the device is being scanned, it may be due to an overload on the Ethernet network. To identify the cause of the error, you can:

- Verify the IOScanner state: %SW212.
- Verify the drive state: %IWNS (300+x).
- Verify the channel state: %IWNS (300+x).y.
- Increase the **Response timeout** of the drive.

AxisErrorId Error Codes

This table lists the possible function block axis error codes returned by the *MC_ReadMotionStatus* function block:

Value	Name
0	No error (nOF)
2	EEPROM control (EEF1)
3	Incorrect configuration (CFF)
4	Invalid Configuration (CFI)
5	Modbus Comm Interruption (SLF1)
6	Internal Link Error (ILF)
7	Fieldbus Com Interrupt (CnF)
8	External Error (EPF1)
9	Overcurrent (OCF)
10	Precharge Capacitor (CrF)

Value	Name
13	AI2 4-20 mA loss (LFF2)
15	Input Overheating (IHF)
16	Drive Overheating (OHF)
17	Motor Overload (OLF)
18	DC Bus Overvoltage (ObF)
19	Supply Mains Overervoltage (OSF)
20	Single Output Phase Loss (OPF1)
21	Input phase loss (PHF)
22	Supply Mains Undervoltage (USF)
23	Motor Short Circuit (SCF1)
24	Motor Overspeed (SOF)
25	Autotuning Error
26	Internal Error 1 (InF1)
27	Internal Error 2 (InF2)
28	Internal Error 3 (InF3)
29	Internal Error 4 (InF4)
30	EEPROM ROM Power (EEF2)
32	Ground Short Circuit (SCF3)
33	Output Phase Loss (OPF2)
37	Internal Error (InF7)
38	Fieldbus Error (EPF2)
40	Internal Error 8 (InF8)
42	PC Com Interruption (SLF2)
45	HMI Com Interruption (SLF3)
51	Internal Error 9 (InF9)
52	Internal Error 10 (InFA)
53	Internal Error 11 (InFb)
54	IGBT Overheating (tJF)
55	IGBT Short Circuit (SCF4)
56	Motor Short Circuit (SCF5)
60	Internal Error 12 (InFC)
64	Input Contactor (LCF)
68	Internal Error 6 (InF6)
69	Internal Error 14 (InFE)
71	AI3 4-20mA Loss (LFF3)
72	AI4 4-20mA Loss (LFF4)
73	Boards Compatibility (HCF)
77	Conf Transfer Error (CFI2)
79	AI5 4-20mA Loss (LFF5)
99	Channel Switch Error (CSF)
100	Process Underload (ULF)
101	Process Overload (OLC)

Value	Name
105	Angle Error (ASF)
106	A11 4-20mA Loss (LFF1)
107	Safety Function Error (SAFF)
110	A12 Th Detected Error (tH2F)
111	A12 Thermal Sensor Error (t2CF)
112	A13 Th Detected Error (tH3F)
113	A13 Thermal Sensor Error (t3CF)
114	Pump Cycle Start Error (PCPF)
119	Pump Low Flow Error (PLFF)
120	A14 Th Detected Error (tH4F)
121	A14 Thermal Sensor Error (t4CF)
122	A15 Th Detected Error (tH5F)
123	A15 Thermal Sensor Error (t5CF)
126	Dry Run Error (drYF)
127	PID Feedback Error (PFMF)
128	Program Loading Error (PGLF)
129	Program Running Error (PGrF)
130	Lead Pump Error (MPLF)
131	Low Level Error (LCLF)
132	High Level Error (LCHF)
142	Internal Error 16 (InFG)
143	Internal Error 17 (InFH)
144	Internal Error 0 (InF0)
146	Internal Error 13 (InFd)
149	Internal Error 21 (InFL)
151	Internal Error 15 (InFF)
152	Firmware Update Error (FEr)
153	Internal Error 22 (InFM)
154	Internal Error 25 (InFP)
155	Internal Error 20 (InF)
157	Internal Error 27 (InFr)

Pulse Train Output (%PTO)

What's in This Chapter

Description	75
Configuration	85
Programming	92
Home Modes	94
Data Parameters	100
Operation Modes.....	105
Motion Function Blocks.....	108
Administrative Function Blocks.....	130

Using Pulse Train Output Function Blocks

This chapter provides descriptions and programming guidelines for using `Pulse Train Output` function blocks.

Description

Overview

This section describes the *Pulse Train Output* function.

Pulse Train Output (PTO)

Introduction

The M221 *PTO* function provides pulse train output channels for a specified number of pulses and a specified velocity (frequency). The *PTO* function is used to control the positioning or speed of independent linear single-axis stepper or servo drives in open loop mode. The *PTO* function does not have any position feedback information from the process. Therefore, position information must be integrated in the drive. The *PLS* (pulse), *PWM* (pulse width modulation), *PTO* (pulse train output), and *FREQGEN* (frequency generator) functions use the same dedicated outputs. Only one of these four functions can be used on the same channel.

A *PTO* channel can use optional interface signals for homing (*Ref*), event (*Probe*), limits (*LimP*, *LimN*), or drive interface (*DriveReady*, *DriveEnable*).

Automatic origin offset and backlash compensation are also managed to improve positioning accuracy. Diagnostics are available for status monitoring.

Supported Functions

The *PTO* channels support the following functions:

- two output modes (two channels for Pulse and Direction or one channel for CW/CCW)
- single axis moves (velocity and position)
- relative and absolute positioning, with automatic direction management
- trapezoidal and S-curve acceleration and deceleration
- homing (four modes with offset compensation)
- dynamic acceleration, deceleration, velocity, and position modification
- switch from speed to position mode
- move queuing (buffer of one move)
- position capture and move trigger on event (using probe input)
- backlash compensation
- limits (hardware and software)
- diagnostics

NOTE: Motion function blocks, page 108 and administrative function blocks, page 130 help you to program these functions.

PTO Characteristics

There are up to five physical inputs for a *PTO* channel:

- Two are assigned to the *PTO* function through configuration and are taken into account upon a rising edge on the input:
 - Ref input
 - Probe input
- Three are assigned to the *MC_Power_PTO*, page 111 function block. They have no fixed assignment (they are not configured in the configuration screen), and are read with all other inputs:
 - *DriveReady* input
 - Limit positive input
 - Limit negative input

NOTE: These inputs are managed like any other regular input, but are used by the *PTO* function when assigned to *MC_Power_PTO*, page 111 function block.

NOTE: The positive and negative limit inputs are required to help prevent over-travel.

▲ WARNING

UNINTENDED EQUIPMENT OPERATION

- Ensure that controller hardware limit switches are integrated in the design and logic of your application.
- Mount the controller hardware limit switches in a position that allows for an adequate braking distance.

Failure to follow these instructions can result in death, serious injury, or equipment damage.

There are up to three physical outputs for a *PTO* channel:

- Two outputs are mandatory to manage the output mode of the *PTO* function. They have a fixed assignment and must be enabled by configuration:
 - CW / CCW
 - Pulse / Direction
- The other output, *DriveEnable*, is associated with the *MC_Power_PTO*, page 111 function block. It has no fixed assignment and is written at the end of the MAST cycle as regular outputs.

The PTO function has the following characteristics:

Characteristic	Value
Number of channels	2 or 4 depending on the module
Number of axis	1 per channel
Position range	-2,147,483,648...2,147,483,647 (32 bits)
Minimum velocity	0 Hz
Maximum velocity	100 kHz (for a 40/60 duty cycle and max. 200 mA)
Minimum step	1 Hz
Accuracy on velocity	1 %
Acceleration / deceleration (min)	1 Hz/ms
Acceleration / deceleration (max)	100 kHz/ms
Origin offset	-2,147,483,648...2,147,483,647 (32 bits)
Software limits range	-2,147,483,648...2,147,483,647 (32 bits)

Pulse Output Modes

Overview

There are two possible output modes:

- ClockWise / CounterClockwise
- Pulse / Direction

ClockWise (CW) / CounterClockwise (CCW) Mode

This mode generates a signal that defines the motor operating speed and direction. This signal is implemented on the first PTO channel (*PTO0* only).

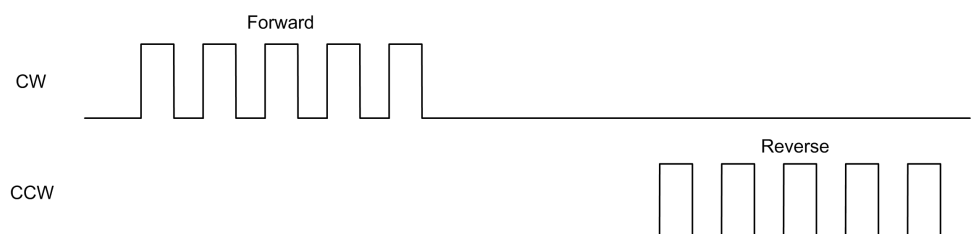

NOTE: *PTO1* is not available when choosing this mode.

Pulse / Direction Mode

This mode generates two signals on the PTO channels:

- The pulse output provides the motor operating speed (*Pulses*).
- The direction output provides the motor rotation direction (*Direction*).

NOTE: The direction output can be disabled if not needed for the application.

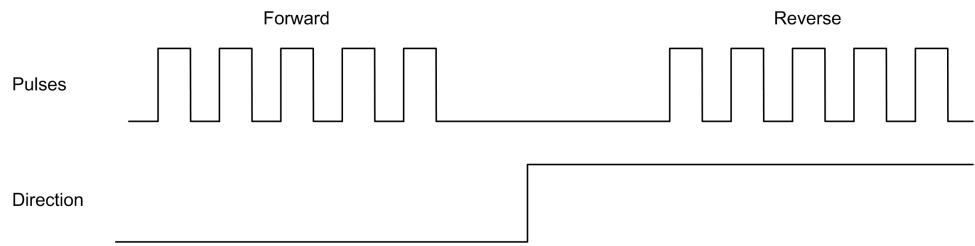

Special Cases

Special Case	Description
Effect of a cold restart (%S0=TRUE)	<ul style="list-style-type: none"> The axis is set to <code>Disabled</code> state. The PTO function blocks are initialized.
Effect of a warm restart (%S1=TRUE)	<ul style="list-style-type: none"> The axis is set to <code>Disabled</code> state. The PTO function blocks are initialized.
Effect at controller stop	<ul style="list-style-type: none"> The axis is set to <code>ErrorStop</code> state. The outputs are reset to 0.
Effect of online modification	None

Acceleration / Deceleration Ramp

Start Velocity

The **Start Velocity** is the minimum frequency at which a stepper motor can produce movement, with a load applied, without the loss of steps.

Start Velocity parameter is used when starting a motion from velocity 0.

Start Velocity must be in the range $0 \dots \text{MaxVelocityAppl}$.

Value 0 means that the **Start Velocity** parameter is not used. In this case, the motion starts at a velocity = acceleration rate x 1 ms.

Stop Velocity

The **Stop Velocity** is the maximum frequency at which a stepper motor stops producing movement, with a load applied, without loss of steps.

Stop Velocity is only used when moving from a higher velocity than **Stop Velocity**, down to velocity 0.

Stop Velocity must be in the range $0 \dots \text{MaxVelocityAppl}$.

Value 0 means that the **Stop Velocity** parameter is not used. In this case, the motion stops at a velocity = deceleration rate x 1 ms.

Acceleration / Deceleration

Acceleration is the rate of velocity change, starting from **Start Velocity** to target velocity. Deceleration is the rate of velocity change, starting from target velocity to **Stop Velocity**. These velocity changes are implicitly managed by the *PTO* function in accordance with *Acceleration*, *Deceleration* and *JerkRatio* parameters following a **trapezoidal** or an **S-curve** profile.

Acceleration / Deceleration Ramp with a Trapezoidal Profile

When the *JerkRatio* parameter is set to 0, the acceleration / deceleration ramp has a trapezoidal profile.

Expressed in Hz/ms, the *Acceleration* and *Deceleration* parameters represent the rate of velocity change.

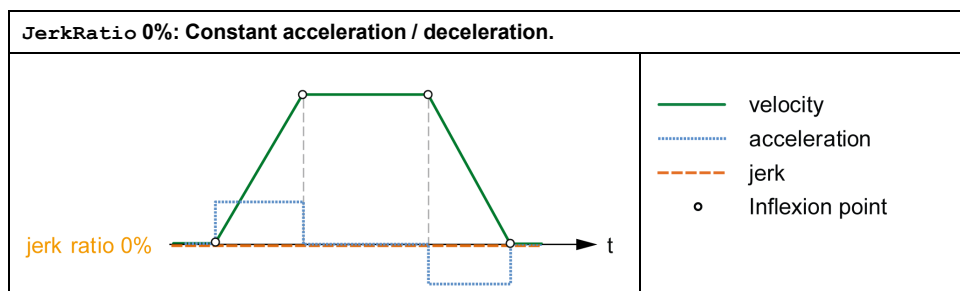

Acceleration / Deceleration Ramp with an S-curve Profile

When the *JerkRatio* parameter is greater than 0, the acceleration / deceleration ramp has an S-curve profile.

The S-curve ramp is used in applications controlling high inertia, or in those that manipulate fragile objects or liquids. The S-curve ramp enables a smoother and progressive acceleration / deceleration, as demonstrated in the following graphics:

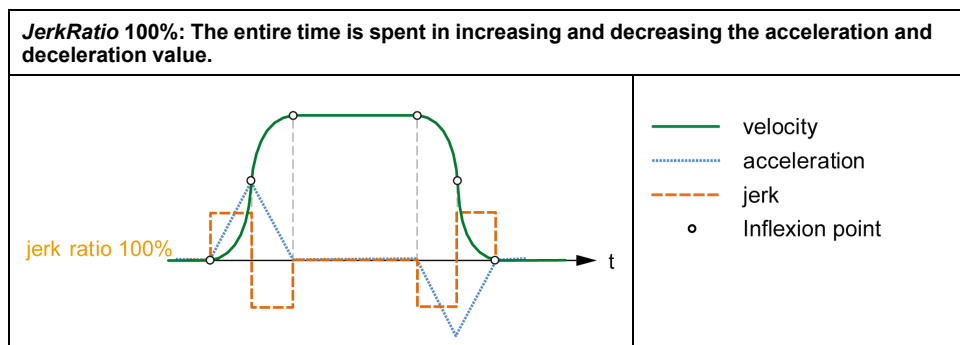
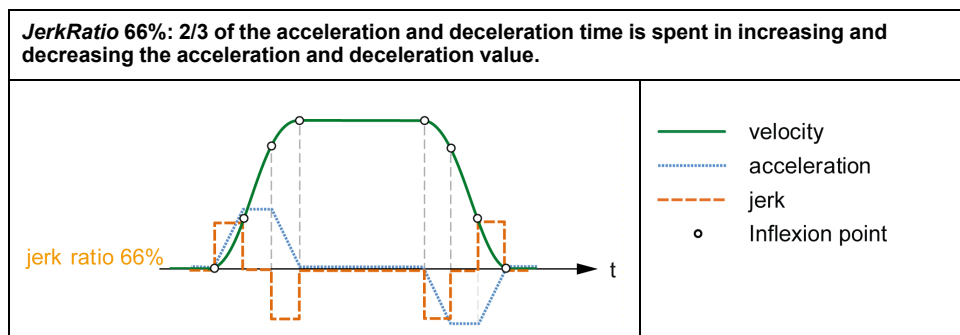

NOTE: The *JerkRatio* parameter value is common for acceleration and deceleration so that concave time and convex time are equal.

Affect of the S-Curve Ramp on Acceleration / Deceleration

The duration for the acceleration / deceleration is maintained, whatever the *JerkRatio* parameter may be. To maintain this duration, the acceleration or deceleration is other than that configured in the function block (*Acceleration* or *Deceleration* parameters).

When the *JerkRatio* is applied, the acceleration / deceleration is affected.

When the *JerkRatio* is applied at 100%, the acceleration / deceleration is two times that of the configured *Acceleration/Deceleration* parameters.

NOTE: If the *JerkRatio* parameter value is invalid, the value is re-calculated to respect the *MaxAccelerationAppl* and *MaxDecelerationAppl* parameters.

JerkRatio is invalid when:

- its value is greater than 100. In this case, a *Jerkratio* of 100 is applied.
- its value is less than 0. In this case, a *Jerkratio* of 0 is applied.

Probe Event

Description

The *Probe* input is enabled by configuration, and activated using the *MC_TouchProbe_PTO* function block.

The *Probe* input is used as an event to:

- capture the position,
- start a move independently of the task.

Both functions can be active at the same time, that is, the same event captures the position and start a motion function block, page 75.

NOTE: Only the first event after the rising edge at the *MC_TouchProbe_PTO* function block *Busy* output is valid. Once the *Done* output is set to TRUE, subsequent events are ignored. The function block needs to be reactivated to respond to other events.

Position Capture

The position captured is available in `%MC_TouchProbe_PTO.RecordedPos`.

Motion Trigger

The *BufferMode* input of a motion function block must be set to *seTrigger*.

This example illustrates a change target velocity with enable window:

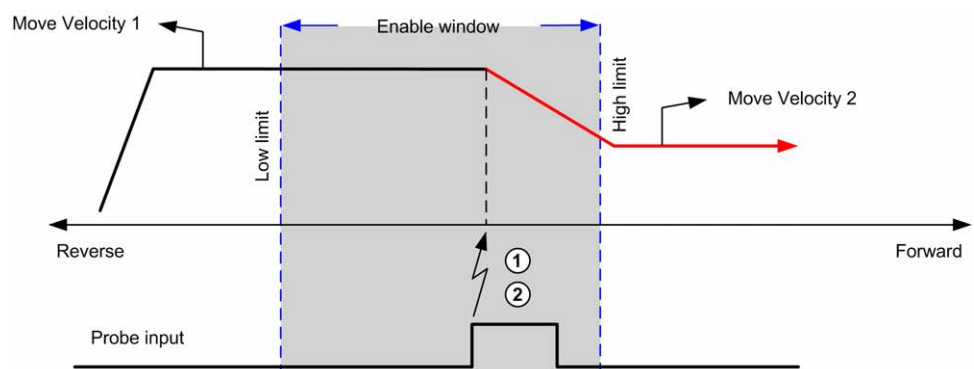

1 Capture the position counter value

2 Trigger *Move Velocity* function block

This example illustrates a move of pre-programmed distance, with simple profile and no enable window:

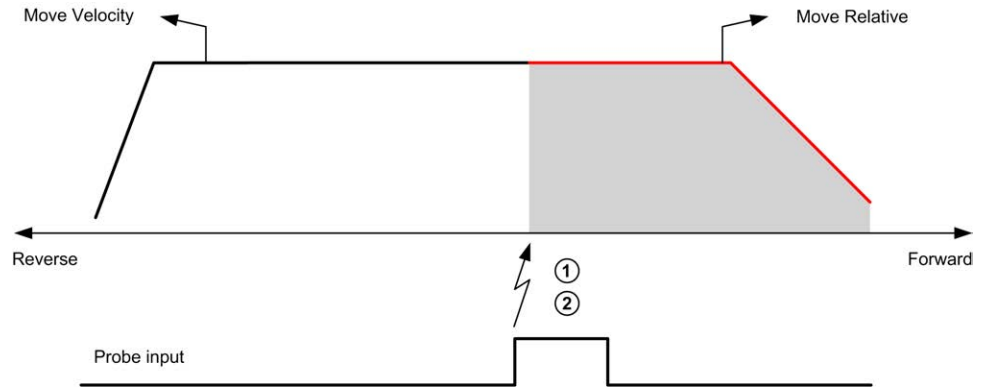

- 1 Capture the position counter value
- 2 Trigger *Move Relative* function block

This example illustrates a move of pre-programmed distance, with complex profile and enable window:

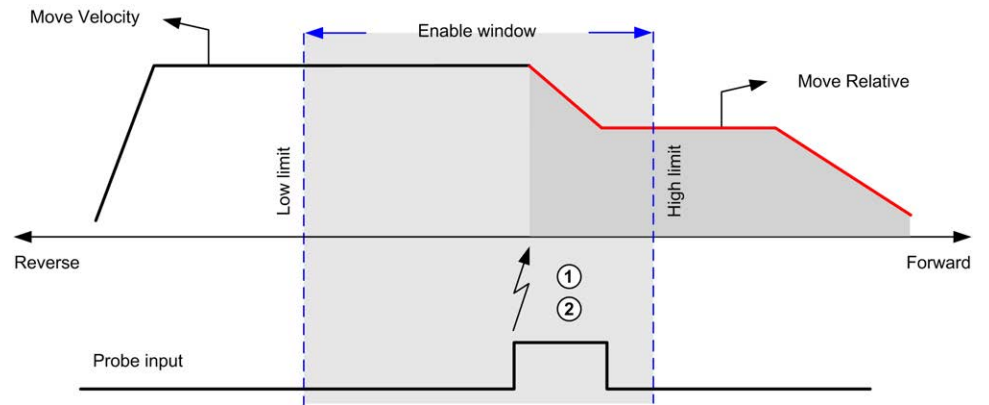

- 1 Capture the position counter value
- 2 Trigger *Move Relative* function block

This example illustrates a trigger event out of enable window:

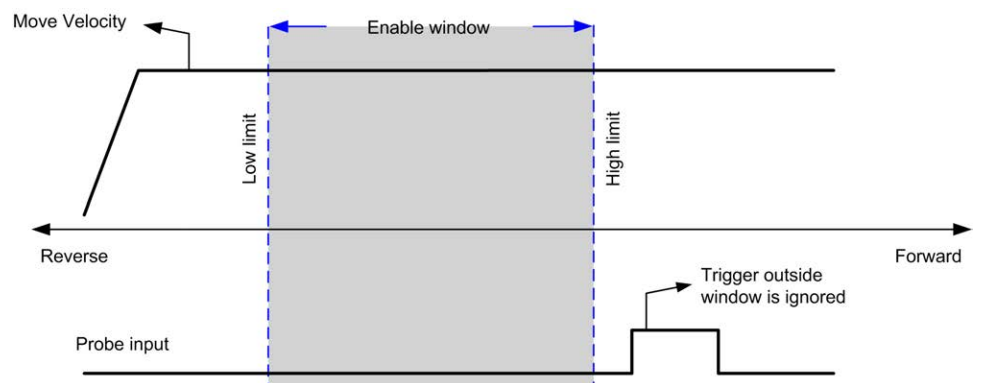

Backlash Compensation

Description

The *Backlash Compensation* parameter is defined as the amount of motion needed to compensate for the mechanical clearance in gears (backlash) when a movement is reversed:

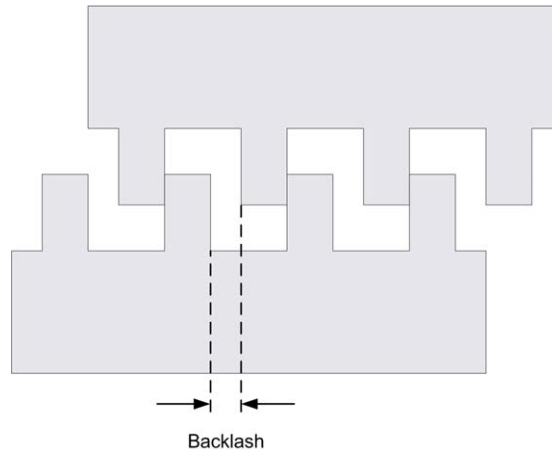

NOTE: The function does not take into account external sources of movement, such as inertia movement or other forms of induced movement.

Backlash compensation is set in number of pulses (0..65535, default value is 0). When set, at each direction reversal, the specified number of pulses is first emitted at start velocity, and then the programmed movement is executed. The backlash compensation pulses are not added to the position counter.

This figure illustrates the backlash compensation:

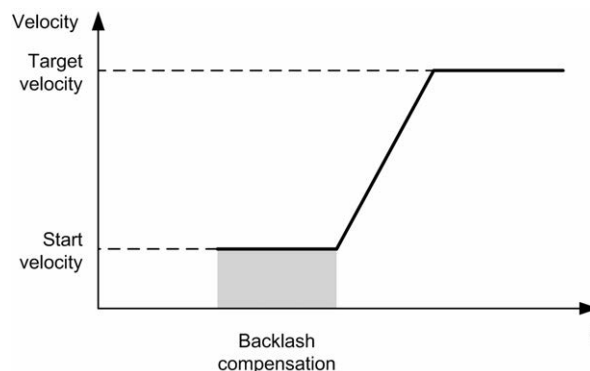

NOTE:

- Before the initial movement is started, the function cannot determine the amount of backlash to compensate for. Therefore, the backlash compensation is only active after a first move is performed and the compensation is applied at the first direction reversal.
- If an aborting command is received or an error detected before the backlash completion, the absolute position remains unchanged.
- After an abort command, the backlash resumes from current backlash position when a new move is started.

For more details, refer to the Configuring Pulse Train Output (see Modicon M221, Logic Controller, Programming Guide).

Positioning Limits

Introduction

Positive and negative limits can be set to control the movement boundaries in both directions. Both hardware and software limits are managed by the controller.

Hardware and software limit switches are used to manage boundaries in the controller application only. They are not intended to replace any functional safety limit switches wired to the drive. The controller application limit switches must necessarily be activated before the functional safety limit switches wired to the drive. In any case, the type of functional safety architecture, which is beyond the scope of the present document, that you deploy depends on your safety analysis, including, but not limited to:

- risk assessment according to EN/ISO 12100
- FMEA according to EN 60812

⚠ WARNING
UNINTENDED EQUIPMENT OPERATION
Ensure that a risk assessment is conducted and respected according to EN/ISO 12100 during the design of your machine.
Failure to follow these instructions can result in death, serious injury, or equipment damage.

The figure illustrates hardware and software limit switches:

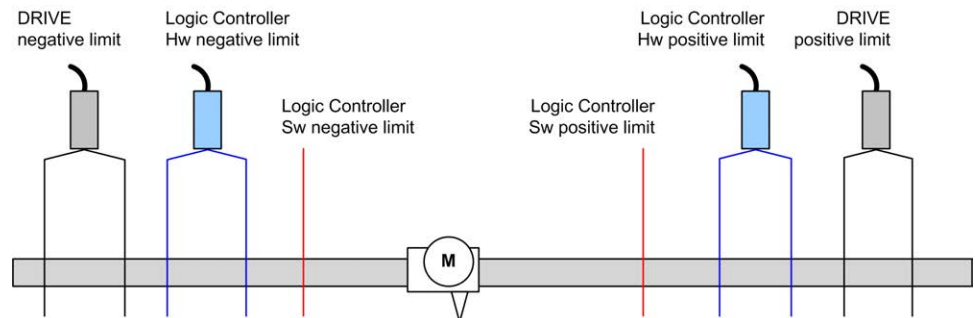

Once either the controller hardware or software limits are crossed, an error is detected and a Fast stop deceleration is performed:

- the axis switches to *ErrorStop* state, with *AxisErrorId* 1002 to 1005. Refer to *MC_ReadAxisError_PTO*, page 136 and *Axis Control Advisory Alerts*, page 102.
- the current direction becomes invalid and the associated PTO parameter *EnableDirPos* (1004) or *EnableDirNeg* (1005) is reset to 0 by the system.
- the function block under execution detects the error state,
- on other applicable function blocks, the *CmdAborted* outputs are set to TRUE.

To clear the axis error state, and return to a *Standstill* state, execution of *MC_Reset_PTO* is required as any motion command will be rejected (refer to PTO parameters, page 101 *EnableDirPos* or *EnableDirNeg*) while the axis remains outside the limits (function block terminates with *ErrorId=InvalidDirectionValue*). It is only possible to execute a motion command in the opposite direction under these circumstances.

Once the axis is inside the limits, the *EnableDirPos* or *EnableDirNeg* parameter is restored to 1 (valid) by the system.

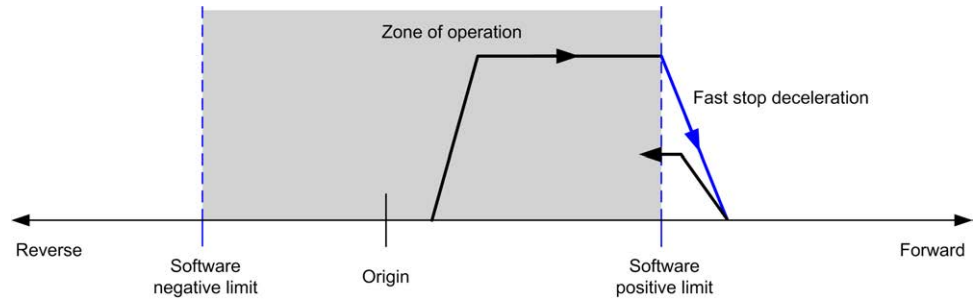

NOTE: In previous diagram, the axis move back in the limits is the result of the execution of *MC_Reset_PTO* (it is not performed automatically).

Software Limits

Software limits can be set to control the movement boundaries in both directions.

Limit values are enabled and set in the configuration screen, such that:

- Positive limit > Negative limit
- Values in the range -2,147,483,648 to 2,147,483,647

They can also be enabled, disabled, or modified in the application program (*MC_WritePar_PTO* and PTO Parameter, page 101).

NOTE: When enabled, the software limits are valid after an initial homing is successfully performed (that is, the axis is homed, *MC_Home_PTO*).

Hardware Limits

Hardware limits are required for the homing procedure, and for helping to prevent damage to the machine. The appropriate inputs must be used on the *%MC_Power_PTO.LimP* and *%MC_Power_PTO.LimN* inputs. The hardware limit devices must be of a normally closed type such that the input to the function block is FALSE when the respective limit is reached.

NOTE: The restrictions over movement are valid while the limit inputs are FALSE and regardless of the sense of direction. When they return to TRUE, movement restrictions are removed and the hardware limits are functionally rearmed. Therefore, use falling edge contacts leading to RESET output instructions prior to the function block. Then use those bits to control these function block inputs. When operations are complete, SET the bits to restore normal operation.

⚠ WARNING

UNINTENDED EQUIPMENT OPERATION

- Ensure that controller hardware limit switches are integrated in the design and logic of your application.
- Mount the controller hardware limit switches in a position that allows for an adequate braking distance.

Failure to follow these instructions can result in death, serious injury, or equipment damage.

NOTE: Adequate braking distance is dependent on the maximum velocity, maximum load (mass) of the equipment being moved, and the value of the Fast stop deceleration parameter.

Configuration

Overview

This section describes how to configure a PTO channel and the associated parameters.

PTO Configuration

Overview

To configure the *Pulse Generator* resource, refer to the Modicon M221 Logic Controller Programming Guide, Configuring Pulse Generators (see Modicon M221, Logic Controller, Programming Guide).

To configure the *Pulse Generator* resource as a PTO, refer to the Modicon M221 Logic Controller Programming Guide, PTO Configuration (see Modicon M221, Logic Controller, Programming Guide).

Motion Task Table

Overview

The Motion Task Table is a programming possibility for motion function blocks, dedicated to repetitive motion sequences. A sequence of movements is defined for an axis at configuration time (a sequence can be compared as a recipe that mixes various movements).

The Motion Task Table can be dedicated to several axes and offers a graphical overview of the configured motion sequence.

Use the *MC_MotionTask_PTO* function block to execute a Motion Task Table. When the table is called by the *MC_MotionTask_PTO* function block, it needs to be associated to a specific axis. The Motion Task Table is applied to the axis used by the *MC_MotionTask_PTO* function block. Several *MC_MotionTask_PTO* function blocks can execute the same %MT Motion Task Table instances simultaneously.

Features

The maximum number of Motion Task Table (%MT) instances is 4.

A Motion Task Table contains a sequence of single-axis movements:

- A sequence is a succession of steps.
- Each step defines the parameters of a movement.
- Each step uses a dedicated motion function block instance.

Movements that can be used in the Motion Task Table:

- Move absolute
- Move relative
- Halt
- Set position
- Move velocity

Configuring a Motion Task Table

The **Motion Task Table Assistant** allows you to configure each movement in an ordered sequence and visualize an estimated global movement profile.

To display the **Motion Task Table Assistant**, proceed as follows:

Step	Action																														
1	<p>Select the Programming > Tools module tab and click PTO objects > Motion Task Tables in the hardware tree to display the Motion Task Table properties.</p> <p>tooltipMotionTaskTables properties</p> <table border="1"> <thead> <tr> <th></th> <th>Configured</th> <th>Address</th> <th>Symbol</th> <th>Configuration</th> <th>Comment</th> </tr> </thead> <tbody> <tr> <td></td> <td><input type="checkbox"/></td> <td>%MT0</td> <td></td> <td></td> <td></td> </tr> <tr> <td></td> <td><input type="checkbox"/></td> <td>%MT1</td> <td></td> <td></td> <td></td> </tr> <tr> <td></td> <td><input type="checkbox"/></td> <td>%MT2</td> <td></td> <td></td> <td></td> </tr> <tr> <td></td> <td><input type="checkbox"/></td> <td>%MT3</td> <td></td> <td></td> <td></td> </tr> </tbody> </table>		Configured	Address	Symbol	Configuration	Comment		<input type="checkbox"/>	%MT0					<input type="checkbox"/>	%MT1					<input type="checkbox"/>	%MT2					<input type="checkbox"/>	%MT3			
	Configured	Address	Symbol	Configuration	Comment																										
	<input type="checkbox"/>	%MT0																													
	<input type="checkbox"/>	%MT1																													
	<input type="checkbox"/>	%MT2																													
	<input type="checkbox"/>	%MT3																													
2	Click [...] to configure the Motion Task Table.																														

Motion Task Table properties window description:

Parameter	Editable	Value	Default Value	Description
Configured	No	True/False	False	Indicates whether the Motion Task Table contains configured steps.
Address	No	%MT x	%MT x	Displays the address of the Motion Task Table where x is the table number.
Symbol	Yes	–	–	Allows you to specify a symbol to associate with the Motion Task Table. Double-click the cell to edit the field.
Configuration	Yes	[...] (Button)	Enabled	Allows you to configure the sequence of movements using the Motion Task Table Assistant .
Comment	Yes	–	–	Allows you to specify a comment to associate with the Motion Task Table. Double-click the cell to edit the field.

Motion Task Table Assistant:

Motion Task Table Assistant
✕

Steps

Step	Type	Pos	Distance	Vel	Acc	Dec	Jerk ratio	Next step	Event	Delay	Software Object
1	MC_MoveAbs_P	2000		5000	20	50	0	Done		10	%MC_MOVEA
2	MC_MoveRel_P*		5000	7500	20	100	0	Done		0	%MC_MOVER
3	MC_MoveRel_P*		5000	4000	20	200	0	SW event %M1	%M1	1000	%MC_MOVER
4	MC_Halt_PTO					1	0	Done		0	%MC_HAL_PT
5	None										
6	None										

Use probe event range

First position
 Last position

Motion overview

ⓘ
The graph presented below may not represent real-world events. Consult the product documentation for more information.

Motion Task Table Assistant main areas:

Parameter	Description
Steps	Lists the sequence of single axis movements and input parameters for each movement.
Motion overview	<p>Click the refresh button, or F5, to generate a graphical view of the movement implemented by the steps sequence.</p> <p>The curve provides a general overview of the movement. The curve is based on the following assumptions:</p> <ul style="list-style-type: none"> Initial position is 0. Position limits are not enabled. Axis default motion configuration parameters are used. An event (probe input, POU) occurs after the step completion and a 100 ms delay. A %MWx delay is graphically represented by a 100 ms delay.

Steps window description:

Parameter	Value	De- fault Value	Description
Step	1...16	–	Single axis movement number in the sequence.
Type	<p>None</p> <p>MC_MoveAbs_PTO (Move absolute)</p> <p>MC_MoveRel_PTO (Move relative)</p> <p>MC_Halt_PTO (Halt)</p> <p>MC_SetPos_PTO (Set position)</p> <p>MC_MoveVel_PTO (Move velocity)</p>	None	<p>Motion command.</p> <p>The motion command uses one motion function block instance indicated in the Software Objects parameter.</p>
Pos	See each software object function block parameter value.	<i>empty</i>	<p>The move parameters are the parameters of the software object assigned to the step.</p> <p>Parameter description:</p> <ul style="list-style-type: none"> • Pos: Position • Distance: Distance • Vel: Velocity • Acc: Acceleration • Dec: Deceleration • Jerk ratio: Jerk ratio <p>NOTE: <i>Vel</i> parameter for the move velocity motion command is a combination of velocity and direction. In the table, the velocity range for the <i>MC_MoveVel_PTO</i> motion command is: - Max Velocity...+ Max Velocity. A negative velocity indicates a negative direction, a positive velocity indicates a positive direction.</p>
Distance			
Vel			
Acc			
Dec			
Jerk ratio			

Parameter	Value	De-fault Value	Description
Next step	Done / In velocity Blending previous Probe input event %M event Delay	<i>empty</i>	<p>The condition that needs to be fulfilled to proceed to the next step in the table sequence.</p> <p>Condition description:</p> <ul style="list-style-type: none"> • Done / In velocity: <ul style="list-style-type: none"> ◦ Done: Proceed to the next step when the present step is completed. This parameter is available for the different motion commands except move velocity. ◦ In velocity: Proceed to the next step when the requested velocity is reached. This parameter is only available for the move velocity motion command. • Blending previous: The velocity of next step is blended with the velocity at the end-position of this step. • Probe input event: Proceed to the next step when a defined event is detected on the Probe input. The edge is defined in the Event parameter. An input field opens in the bottom of the Steps window, Use probe event range, described in next table. NOTE: One occurrence of Probe input event can be used per Motion Task Table. • %M event: Proceed to the next step when the memory bit address (<i>%Mx</i>) set in the Event parameter is set to 1. • Delay: Proceed to the next step when the delay (starting at the beginning of the step) elapses. The delay is defined in the Delay parameter. <p>NOTE: When the Probe input event, %M event, or Delay event occurs, the next step is started even if the present step is not completed.</p>
Event	– 0/1 %Mx	<i>empty</i>	<p>Event value complements the conditions described in the Next step parameter.</p> <p>Next step choice and corresponding Event choice:</p> <ul style="list-style-type: none"> • Probe input event: <ul style="list-style-type: none"> ◦ 0: Falling edge ◦ 1: Rising edge NOTE: The probe input event is independent of the application task cycle and the motion task cycle. • %M event: Memory bit <i>%Mx</i>. NOTE: <i>%Mx</i> is evaluated every 4 ms.

Parameter	Value	De- fault Value	Description
Delay	0...65535 %MWx	empty	<p>Delay value represents the amount of time before proceeding to the next step. Depending on the Next step parameter value, the Delay is evaluated from the beginning or the end of the step:</p> <ul style="list-style-type: none"> • Done / In velocity: The delay starts when the present step is Done or In velocity. • Blending previous: Not available. • Probe input event and %M event: The delay starts at the beginning of the step. <ul style="list-style-type: none"> ◦ An elapsed delay generates a timeout if the event did not occur, and next step is proceeded. ◦ If the event occurs before the end of the delay, the next step is proceeded and the delay timeout is aborted. <p>NOTE: If Delay remains at its default value (0), the motion command waits for the probe input or software event to occur, without timeout.</p> <ul style="list-style-type: none"> • Delay: The delay starts at the beginning of the step. The next step is proceeded when the delay is elapsed. <p>NOTE: An immediate value cannot be modified in an application POU, whereas, a %MWx value must be set by an application POU. The Motion Task Table Delay parameter is not modified if <i>MC_ReadPar_PTO</i> or <i>MC_WritePar_PTO</i> are set using <i>ParNumber</i> = 1000 (delay).</p>
Software Objects	%MC_MOVEABS_PTOx %MC_MOVEREL_PTOx %MC_HALT_PTOx %MC_SETPOS_PTOx %MC_MOVEVEL_PTOx	empty	Shows the software object allocated to the step. It is allocated by the system and is a read-only parameter. Those software objects are function block instances.
Symbol	–	empty	Allows to specify a symbol to associate with the step software object. Double-click the cell to edit the field.

Use probe event range parameter in the **Steps** window:

Parameter	Value	Default Value	Description
Use probe event range	True/False	False	When TRUE, a trigger event is only recognized within the position range defined between First position and Last position . The parameter can be modified if Next step is set to Probe input event in the Motion Task Table.
Last position	- 2147483648... 2147483647 %MDx	2147483647	
First position	- 2147483648... 2147483647 %MDx	- 2147483648	NOTE: First position must be less than Last position .
Illustration of the position range influence on triggering is provided in the section on Probe Event, page 80. NOTE: The position where the trigger event was detected is not recorded.			

Managing Step Parameters and Event

The parameters and event defined in a step are only valid at the start of the step execution, therefore:

- A step parameter value modified by the application is only valid if it is modified before the step is active. The parameter can be modified using system allocated software object parameter in a POU.
- A memory object value (%MW or %MWx) is only valid if updated before the step is active.
- An event is only evaluated once the step is active. In the case of a *Probe input event*, an event occurring before the step is active cannot be detected.

Managing Function Block Instances Used in a Motion Task Table

System allocated software object instances:

- cannot be used in an application POU to control an axis motion.
- Output parameters are not updated by the system during the execution of the Motion Task Table. In other words, the output bits and output parameters are not valid.
- Input parameters:
 - cannot be modified in the software object instance editor, or in the **Programming** tab.
 - can be used to dynamically modify the Motion Task Table in an application POU. To dynamically modify a system allocated software object instance input parameter, use the parameter address or its associated symbol.

NOTE: The executing step can be modified but the modifications will not be taken into account until the next execution of the step.

Example of movement described in a Motion Task Table:

- Step: 2
- Movement type: Move relative
- Software object: %MC_MOVEREL_PTO1
- Symbol: *Move_Relative_Label2*

In previous example, the velocity input parameter can be modified by program using one of the following syntaxes:

- %MC_MOVEREL_PTO1.Vel
- *Move_Relative_Label2.Vel*

Management of the function block instances used in a Motion Task Table:

- When a Motion Task Table is configured, the reserved function block instances are set as **Used**.
- If all the instances of a specific function block are reserved, the associated move type cannot be used anymore.

Programming

Overview

This section lists the function blocks used to program the *PTO* function and describes how to add or remove those function blocks.

Adding / Removing a Function Block

Adding a Function Block

Follow these steps to add an instance of a *PTO* function block:

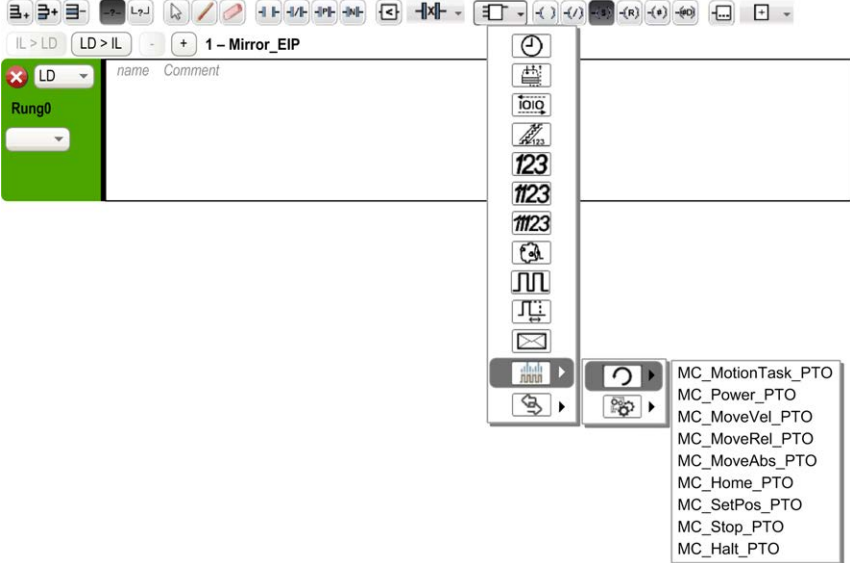
Step	Action
1	Select the Programming tab.
2	<p>Select Function Blocks > PTO > Administrative or Function Blocks > PTO > Motion as shown in the following graphic:</p> 
3	Click into the rung to place the selected function block.
4	Associate the input/output variables of the function block.

NOTE: Set the parameters in the **Configuration** tab.

For more details, refer to the Modicon M221 Logic Controller Programming Guide, PTO Configuration.

Removing a Function Block

Follow these steps to remove an instance of a *PTO* function block:

Step	Action
1	In the Programming tab, click the instance of the function block.
2	Press Delete to remove the selected function block.

PTO Function Blocks

Function Blocks

The PTO function is programmed in EcoStruxure Machine Expert - Basic using the following function blocks:

Category	Function Block	Description
Motion (single axis), page 108	<i>MC_MotionTask_PTO</i> , page 108	Calls a Motion Task Table.
	<i>MC_Power_PTO</i> , page 111	Enables power to the axis, switching the axis state from <i>Disabled</i> to <i>Standstill</i> . While the <i>%MC_Power_PTO.Status</i> bit is <i>FALSE</i> , no motion function block can be executed for that axis.
	<i>MC_MoveVel_PTO</i> , page 114	Causes the specified axis to move at the specified speed, and transfer the axis to the state <i>Continuous</i> . This continuous movement is maintained until a software limit is reached, an aborting move is triggered, or a transition to <i>ErrorStop</i> state is detected.
	<i>MC_MoveRel_PTO</i> , page 117	Moves the specified axis an incremental distance at the specified speed, and transfer the axis to the state <i>Discrete</i> . The target position is referenced from the current position at execution time, incremented by a distance.
	<i>MC_MoveAbs_PTO</i> , page 120	Causes the specified axis to move towards a given position at the specified speed, and transfer the axis to the state <i>Discrete</i> . The function block terminates with <i>Error</i> set to TRUE if the axis is not Homed (no absolute reference position is defined). In this case, <i>ErrorId</i> is set to <i>InvalidAbsolute</i> .
	<i>MC_Home_PTO</i> , page 123	Commands the axis to perform the sequence defining the absolute reference position, and transfers the axis to the state <i>Homing</i> , page 94. The details of this sequence depend on <i>Homing</i> configuration parameters setting.
	<i>MC_SetPos_PTO</i> , page 125	Modifies the coordinates of the axis without any physical movement.
	<i>MC_Stop_PTO</i> , page 126	Commands a controlled motion stop and transfers the axis to the state <i>Stopping</i> . It aborts any ongoing move execution.
	<i>MC_Halt_PTO</i> , page 128	Commands a controlled motion stop until the velocity is zero, and transfers the axis to the state <i>Discrete</i> . With the <i>Done</i> output set to TRUE, the state is transferred to <i>Standstill</i> .
Administrative, page 130	<i>MC_ReadActVel_PTO</i> , page 130	Returns the value of the velocity of the axis.
	<i>MC_ReadActPos_PTO</i> , page 132	Returns the value of the position of the axis.
	<i>MC_ReadSts_PTO</i> , page 133	Returns the state diagram, page 105 status of the axis.
	<i>MC_ReadMotionState_PTO</i> , page 135	Returns the motion status of the axis.
	<i>MC_ReadAxisError_PTO</i> , page 136	Returns an axis control error, if any.
	<i>MC_Reset_PTO</i> , page 138	Resets all axis-related errors, conditions permitting to allow a transition from the states <i>ErrorStop</i> to <i>Standstill</i> . It does not affect the output of the function blocks instances.
	<i>MC_TouchProbe_PTO</i> , page 139	Activates a trigger event on the probe input. This trigger event allows to record the axis position, and/or to start a buffered move.
	<i>MC_AbortTrigger_PTO</i> , page 141	Aborts function blocks which are connected to trigger events (for example, <i>MC_TouchProbe_PTO</i>).
	<i>MC_ReadPar_PTO</i> , page 142	Gets parameters from the PTO.
	<i>MC_WritePar_PTO</i> , page 143	Writes parameters to the PTO.

NOTE: The motion function blocks act on the position of the axis according to the motion state diagram. The administrative function blocks do not influence the motion state.

NOTE: The *MC_Power_PTO*, page 111 function block is mandatory before a move command can be issued.

▲ WARNING

UNINTENDED EQUIPMENT OPERATION

- Do not use the same function block instance in different program tasks.
- Do not change the function block reference (AXIS) while the function block is executing.

Failure to follow these instructions can result in death, serious injury, or equipment damage.

Home Modes

Overview

This section describes the PTO home modes.

Homing Modes

Description

Homing is the method used to establish the reference point or origin for absolute movement.

A homing movement can be made using different methods. The M221 PTO channels provide several standard homing movement types:

- position setting, page 96,
- long reference, page 96,
- short reference reversal, page 98,
- short reference no reversal, page 97,

A homing movement must be terminated without interruption for the new reference point to be valid.

- *%MC_ReadSts_PTO.IsHomed* is set to TRUE when a homing movement is finished successfully. If the homing movement is interrupted, it needs to be started again.
- *%MC_ReadSts_PTO.IsHomed* is set to FALSE when the axis state is DISABLED, or when no homing movement was finished successfully.

Refer to *MC_Home_PTO*, page 123 and home modes function block object codes, page 101.

Home Position

Homing is done with an external switch and the homing position is defined on the switch edge. Then the motion is decelerated until stop.

The actual position of the axis at the end of the motion sequence may therefore differ from the position parameter set on the function block:

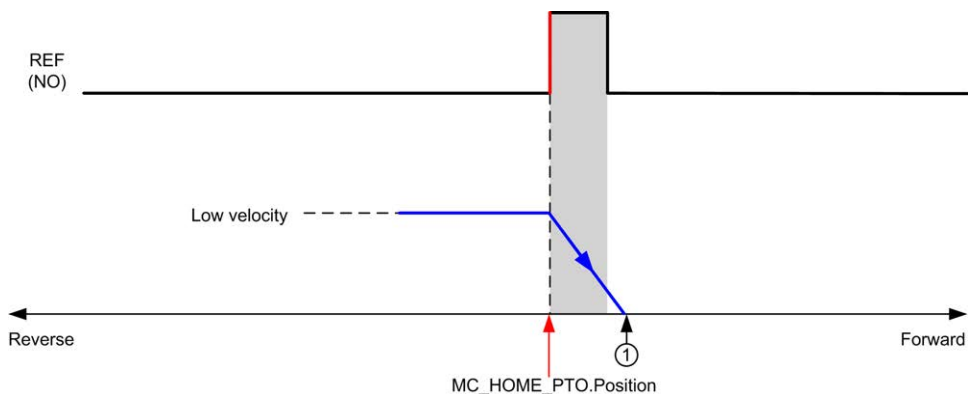

REF (NO) Reference point (Normally Open)

¹ Position at the end of motion = %MC_HOME_PTO.Position + “deceleration to stop” distance.

To simplify the representation of a stop in the homing mode diagrams, the following presentation is made to represent the actual position of the axis:

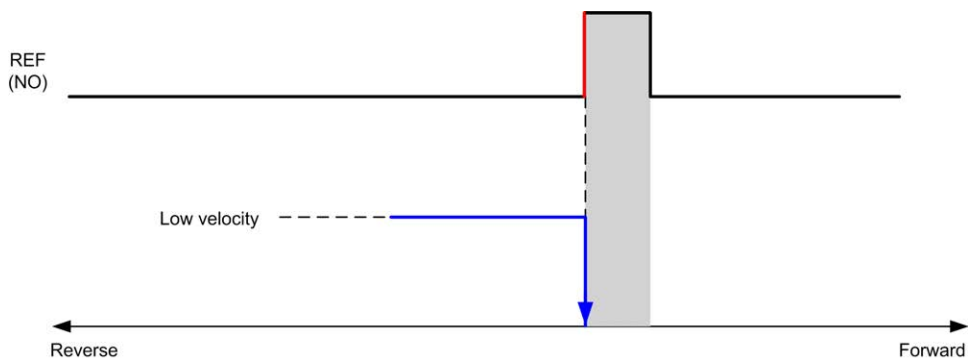

REF (NO) Reference point (Normally Open)

Limits

Hardware limits are necessary for the correct functioning of the *MC_Home_PTO* function block (*Positioning Limits*, page 83 and *MC_Power_PTO*). Depending on the movement type you request with the homing mode, the hardware limits help assure that the end of travel is respected by the function block.

When a homing action is initiated in a direction away from the reference switch, the hardware limits serve to either:

- indicate a reversal of direction is required to move the axis toward the reference switch or,
- indicate that an error has been detected as the reference switch was not found before reaching the end of travel.

For homing movement types that allow for reversal of direction, when the movement reaches the hardware limit the axis stops using the configured deceleration, and resumes motion in a reversed direction.

In homing movement types that do not allow for the reversal of direction, when the movement reaches the hardware limit, the homing procedure is aborted and the axis stops with the Fast stop deceleration.

⚠ WARNING

UNINTENDED EQUIPMENT OPERATION

- Ensure that controller hardware limit switches are integrated in the design and logic of your application.
- Mount the controller hardware limit switches in a position that allows for an adequate braking distance.

Failure to follow these instructions can result in death, serious injury, or equipment damage.

NOTE: Adequate braking distance is dependent on the maximum velocity, maximum load (mass) of the equipment being moved, and the value of the Fast stop deceleration parameter.

Position Setting

Description

In the case of position setting, the current position is set to the specified position value. No move is performed.

Long Reference

Long Reference: Positive Direction

Homes to the reference switch falling edge in reverse direction.

The initial direction of motion is dependent on the state of the reference switch:

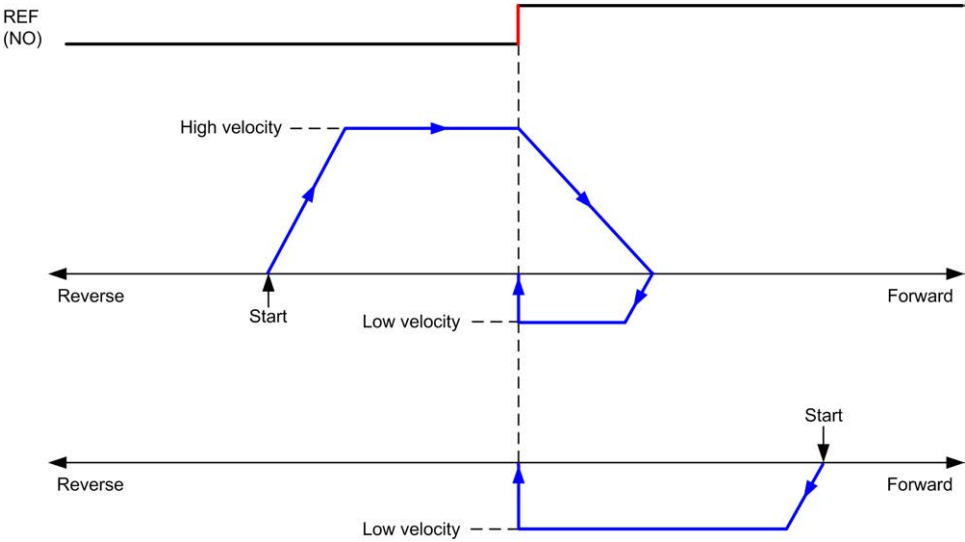

REF (NO) Reference point (Normally Open)

Long Reference: Negative Direction

Homes to the reference switch falling edge in forward direction.

The initial direction of motion is dependent on the state of the reference switch:

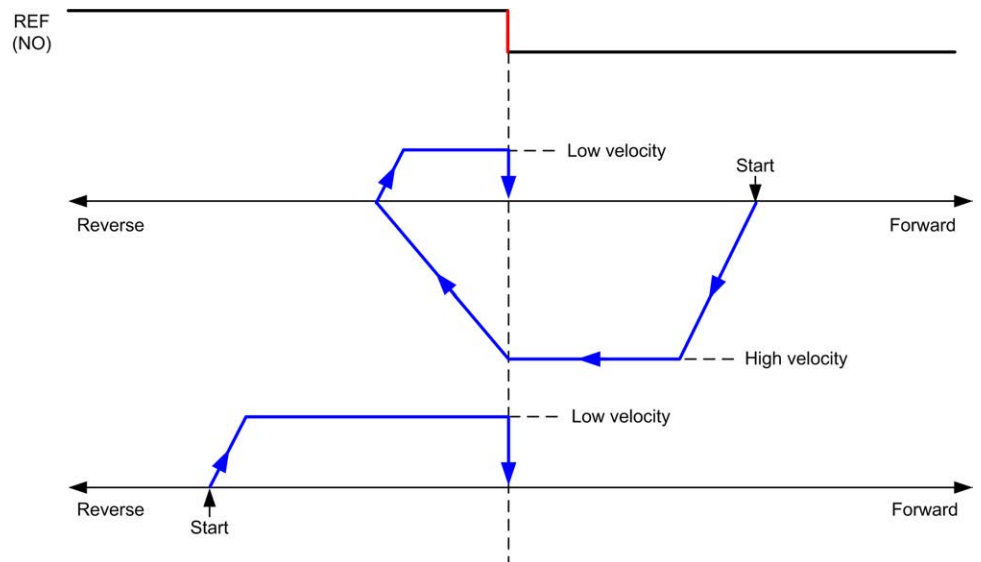

REF (NO) Reference point (Normally Open)

Short Reference No Reversal

Short Reference No Reversal: Positive Direction

Homes at low speed to the reference switch rising edge in forward direction, with no reversal:

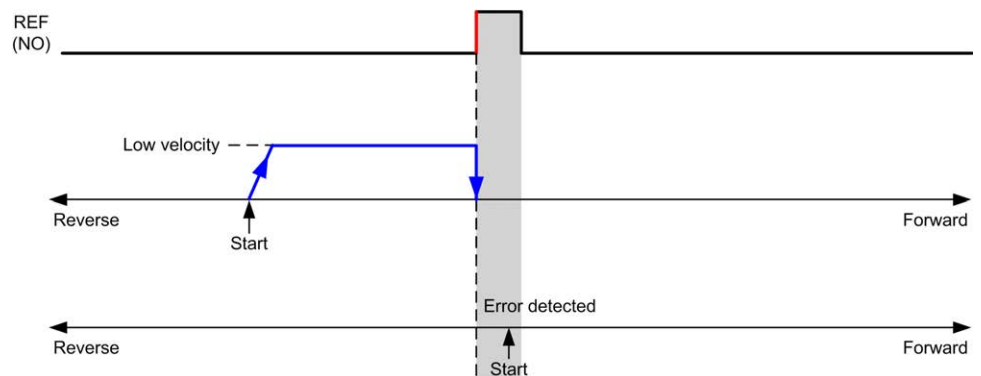

REF (NO) Reference point (Normally Open)

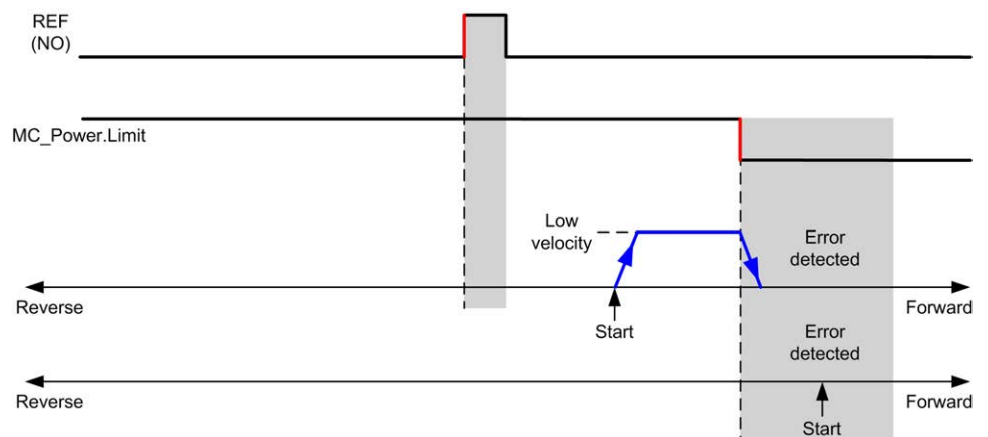

REF (NO) Reference point (Normally Open)

Short Reference No Reversal: Negative Direction

Homes at low speed to the reference switch falling edge in reverse direction, with no reversal:

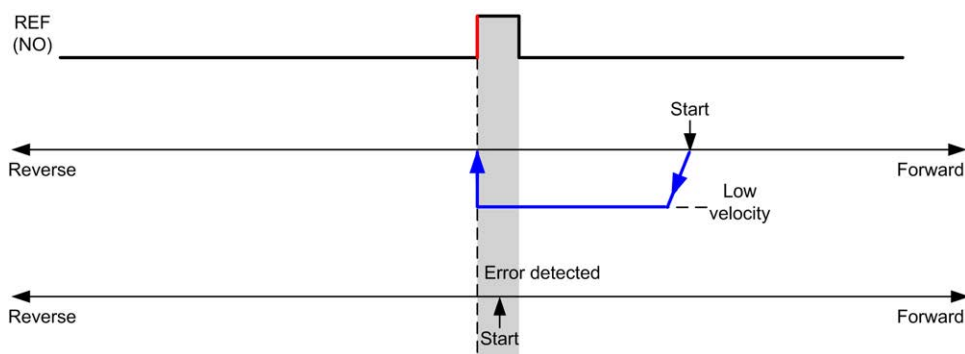

REF (NO) Reference point (Normally Open)

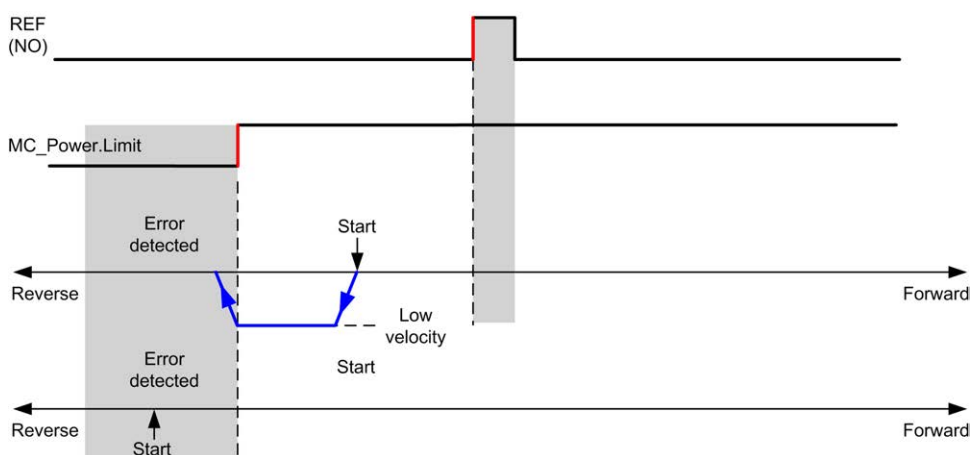

REF (NO) Reference point (Normally Open)

Short Reference Reversal

Short Reference Reversal: Positive Direction

Homes to the reference switch rising edge in forward direction.

The initial direction of motion is dependent on the state of the reference switch:

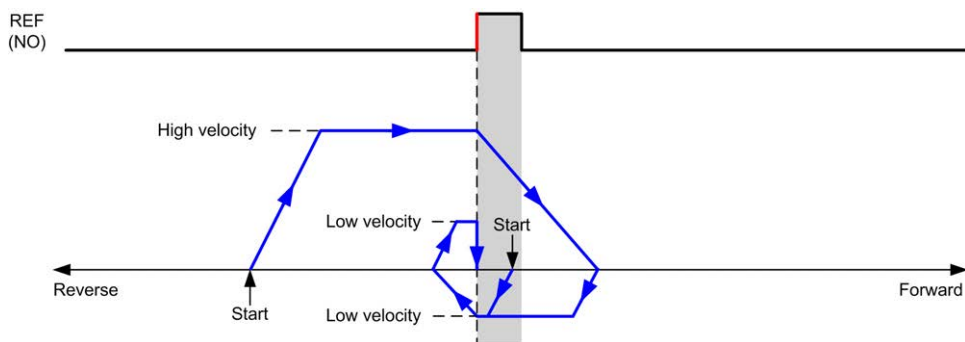

REF (NO) Reference point (Normally Open)

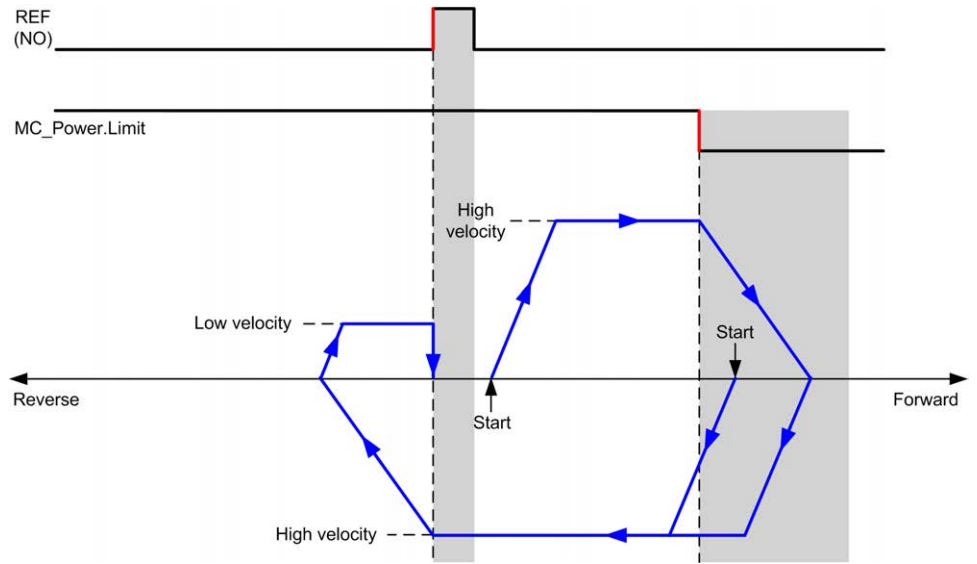

REF (NO) Reference point (Normally Open)

Short Reference Reversal: Negative Direction

Homes to the reference switch rising edge in forward direction.

The initial direction of motion is dependent on the state of the reference switch:

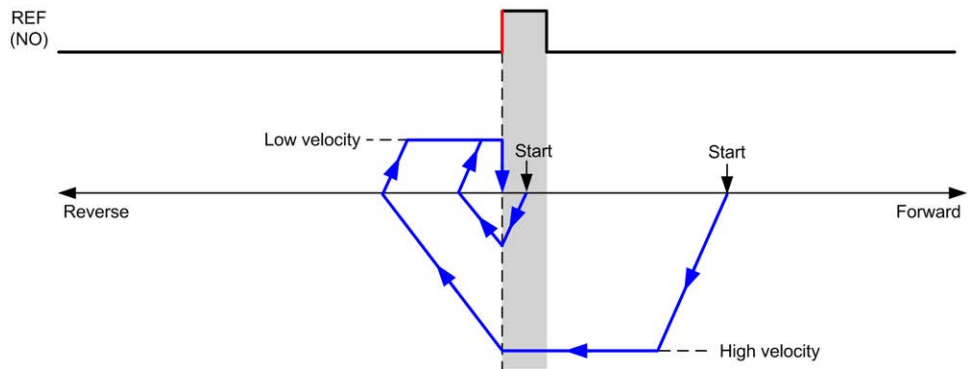

REF (NO) Reference point (Normally Open)

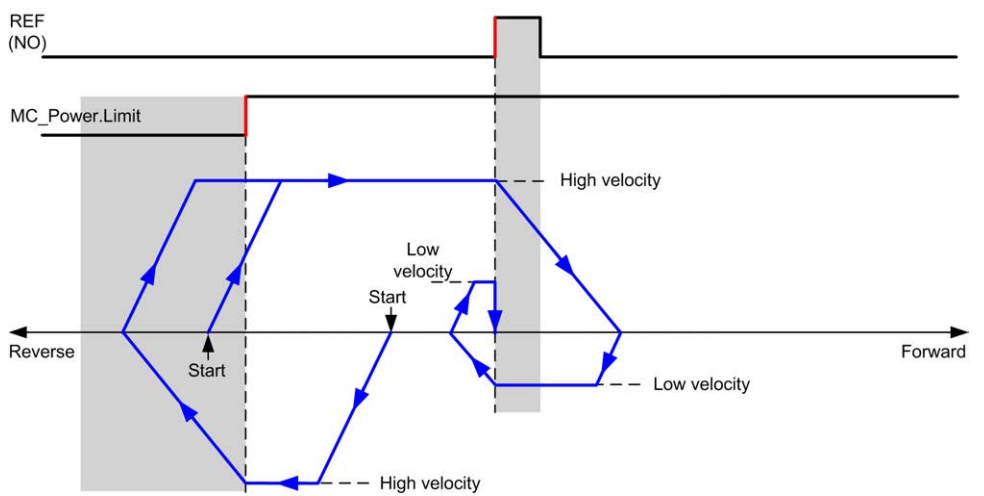

REF (NO) Reference point (Normally Open)

Home Offset

Description

If the origin cannot be defined by switches with enough accuracy, it is possible to make the axis move to a specific position away from the origin switch. Home offset allows making a difference between mechanical origin and electrical origin.

Home offset is set in number of pulses (-2,147,483,648...2,147,483,647, default value 0). When set by configuration, the *MC_Home_PTO* command is executed first, and then the specified number of pulses is output at the home low velocity in the specified direction.

NOTE: The wait time between *MC_Home_PTO* command stop on origin switch and start of offset movement is fixed, set to 500 ms. The *MC_Home_PTO* command busy flag is only released after origin offset has been completed.

Data Parameters

Overview

This section describes the data parameters of the *PTO* function.

Function Block Object Codes

Direction

This table lists the values for the direction function block object codes:

Name	Value	Description
<i>mcPositiveDirection</i>	1	CW, forward, positive (according to Output Mode configuration setting).
<i>mcNegativeDirection</i>	-1	CCW, backward, reverse, negative (according to Output Mode configuration setting).

Buffer Modes

This table lists the values for the buffer modes function block object codes:

Name	Value	Description
<i>mcAborting</i>	0	Start FB immediately (default mode). Any ongoing motion is aborted. The move queue is cleared.
<i>mcBuffered</i>	1	Start FB after current motion has finished (<i>Done</i> or <i>InVel</i> bit is set to TRUE). There is no blending.
<i>mcBlendingPrevious</i>	3	The velocity is blended with the velocity of the first FB (blending with the velocity of <i>FB1</i> at end-position of <i>FB1</i>).
<i>seTrigger</i>	10	Start FB immediately when an event on the Probe input is detected. Any ongoing motion is aborted. The move queue is cleared.
<i>seBufferedDelay</i>	11	Start FB after current motion has finished (<i>Done</i> or <i>InVel</i> output is set to TRUE) and the time delay has elapsed. There is no blending. The <i>Delay</i> parameter is set using <i>MC_WritePar_PTO</i> , with <i>ParameterNumber</i> 1000.

Homing Modes

This table lists the values for the homing modes function block object codes:

Name	Value	Description
<i>PositionSetting</i>	0	Position.
<i>LongReference</i>	1	Long reference.
<i>ShortReference_Reversal</i>	20	Short reference.
<i>ShortReference_NoReversal</i>	21	Short reference no reversal.

PTO Parameter

This table lists the values for the PTO parameters function block object codes:

Name	Parameter Number	R/W	Description
<i>CommandedPosition</i>	1	R	Commanded position.
<i>SWLimitPos (High Limit)</i>	2	R/W	Positive software position limit.
<i>SWLimitNeg (Low Limit)</i>	3	R/W	Negative software position limit.
<i>EnableLimitPos (Enable the Software Position Limits)</i>	4	R/W	Enable positive software limit switch (0...1).
<i>EnableLimitNeg (Enable the Software Position Limits)</i>	5	R/W	Enable negative software limit switch (0...1).
<i>MaxVelocityAppl (Max. Velocity)</i>	9	R/W	Maximal allowed velocity of the axis in the application (0...100,000).
<i>ActualVelocity</i>	10	R	Velocity of the axis.
<i>CommandedVelocity</i>	11	R	Commanded velocity.
<i>MaxAccelerationAppl (Max. acc.)</i>	13	R/W	Maximal allowed acceleration of the axis in the application (0...100,000).

Name	Parameter Number	R/W	Description
<i>MaxDecelerationAppl (Max. dec.)</i>	15	R/W	Maximal allowed deceleration of the axis in the application (0...100,000).
Reserved	16 to 999	-	Reserved for the PLCopen standard.
<i>Delay</i>	1000	R/W	Time in ms (0...65,535) Default value: 0
<i>EnableDirPos</i>	1004	R/W	Enable positive direction. When value = 0, the positive direction is not allowed on the axis. A move function block that would generate a move in a positive direction ends with <i>InvalidDirectionValue</i> error detected (3006). If there is an ongoing movement in the negative direction, and it is interrupted by a new move command in the positive direction, the error will be detected only at the end of the deceleration of the ongoing negative movement. Default value: 1 NOTE: A value change is only taken into account at the next move command or the next occurrence of velocity = 0.
<i>EnableDirNeg</i>	1005	R/W	Enable negative direction. When value = 0, the negative direction is not allowed on the axis. A move function block that would generate a move in a negative direction ends with <i>InvalidDirectionValue</i> error detected (3006). If there is an ongoing movement in the positive direction, and it is interrupted by a new move command in the negative direction, the error will be detected only at the end of the deceleration of the ongoing positive movement. Default value: 1 NOTE: A value change is only taken into account at the next move command or the next occurrence of velocity = 0.

PTO Axis Error Codes

This table lists the values for the PTO axis error codes:

Name	Value	Description
<i>NoError</i>	0	No error detected.
Axis Control Alerts		
<i>InternalError</i>	1000	Motion controller internal error detected.
<i>DisabledAxis</i>	1001	The move could not be started or has been aborted because the axis is not ready.
<i>HwPositionLimitP</i>	1002	Hardware positive position limit <i>limP</i> exceeded.
<i>HwPositionLimitN</i>	1003	Hardware negative position limit <i>limN</i> exceeded.
<i>SwPositionLimitP</i>	1004	Software positive position limit exceeded.
<i>SwPositionLimitN</i>	1005	Software negative position limit exceeded.
<i>ApplicationStopped</i>	1006	Application execution has been stopped (controller in <i>STOPPED</i> or <i>HALT</i> state).

Name	Value	Description
<i>OutputProtection</i>	1007	Short-circuit output protection is active on the PTO channels. Refer to the description of %S10 and %SW139 in the Modicon M221 Logic Controller - Programming Guide, system bits and system words (see Modicon M221, Logic Controller, Programming Guide).
<i>OutputReset</i>	1008	%S9 forced all outputs to be set to 0. Refer to System Bits.
Axis Control Advisories		
<i>WarningVelocityValue</i>	1100	Commanded Velocity parameter is out of range, therefore velocity is limited to the configured maximum velocity.
<i>WarningAccelerationValue</i>	1101	Commanded Acceleration parameter is out of range, therefore acceleration is limited to the configured maximum acceleration.
<i>WarningDecelerationValue</i>	1102	Commanded Deceleration parameter is out of range, therefore deceleration is limited to the configured maximum deceleration.
<i>WarningJerkRatioValue</i>	1103	Commanded jerk ratio parameter is limited by the configured maximum acceleration or deceleration. In this case, the jerk ratio is recalculated to respect these maximums.

An **Axis Control Alert** switches the axis in **ErrorStop** state (*MC_Reset_PTO* is mandatory to get out of **ErrorStop** state). The resulting axis status is reflected by *MC_ReadSts_PTO* and *MC_ReadAxisError_PTO*.

PTO Motion Command Error Codes

This table lists the values for the PTO motion command error codes:

Name	Value	Description
<i>NoError</i>	0	No error detected.
Motion State Advisory Alerts		
<i>ErrorStopActive</i>	2000	The move could not be started or has been aborted because motion is prohibited by an ErrorStop condition.
<i>StoppingActive</i>	2001	The move could not be started because motion is prohibited by <i>MC_Stop_PTO</i> having control of the axis (either the axis is stopping, or <i>MC_Stop_PTO.Execute</i> input is held TRUE).
<i>InvalidTransition</i>	2002	Transition not allowed, refer to the Motion State Diagram.
<i>InvalidSetPosition</i>	2003	<i>MC_SetPos_PTO</i> cannot be executed while the axis is moving.
<i>HomingError</i>	2004	Homing sequence cannot start on reference cam in this mode.
<i>InvalidProbeConf</i>	2005	The Probe input must be configured.
<i>InvalidHomingConf</i>	2006	The Ref input must be configured for this homing mode.
<i>InvalidAbsolute</i>	2007	An absolute move cannot be executed while the axis is not successfully homed to an origin position. A homing sequence must be executed first (<i>MC_Home_PTO</i>).
<i>MotionQueueFull</i>	2008	The move could not be buffered because the motion queue is full.
<i>InvalidTransitionMotionTask</i>	2009	The motion task and the other motion function blocks linked to the same axis cannot be executed concurrently.
Range Advisory Alerts		

Name	Value	Description
<i>InvalidAxis</i>	3000	The function block is not applicable for the specified axis.
<i>InvalidPositionValue</i>	3001	Position parameter is out of limits, or distance parameter gives an out of limits position.
<i>InvalidVelocityValue</i>	3002	Velocity parameter is out of range.
<i>InvalidAccelerationValue</i>	3003	Acceleration parameter is out of range.
<i>InvalidDecelerationValue</i>	3004	Deceleration parameter is out of range.
<i>InvalidBufferModeValue</i>	3005	Buffer mode does not correspond to a valid value.
<i>InvalidDirectionValue</i>	3006	Direction does not correspond to a valid value, or direction is invalid due to software or hardware position limit exceeded.
<i>InvalidHomeMode</i>	3007	Homing mode is not applicable.
<i>InvalidParameter</i>	3008	The parameter number does not exist for the specified axis.
<i>InvalidParameterValue</i>	3009	Parameter value is out of range.
<i>ReadOnlyParameter</i>	3010	Parameter is read-only.
<i>InvalidStepMotionTask</i>	3011	Motion task step type is not defined.

A **Motion State Alert** or a **Range Alert** does not affect the axis state, nor any move currently executing, nor the move queue. In this case, the error is only local to the applicable function block: the *Error* output is set to TRUE, and the *ErrorId* object output is set to the appropriate PTO motion command error code.

Operation Modes

Overview

This section describes the operation modes.

Motion State Diagram

State Diagram

The axis is always in one of the defined states in this diagram:

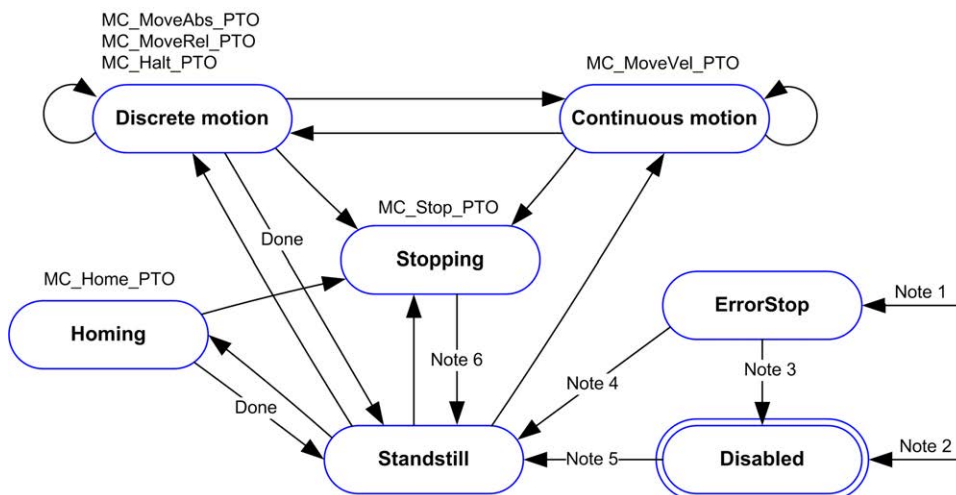

Note 1 From any state, when an error is detected.

Note 2 From any state except *ErrorStop*, when `%MC_Power_PTO.Status = FALSE`.

Note 3 `%MC_Reset_PTO.Done = TRUE` and `%MC_Power_PTO.Status = FALSE`.

Note 4 `%MC_Reset_PTO.Done = TRUE` and `%MC_Power_PTO.Status = TRUE`.

Note 5 `%MC_Power_PTO.Status = TRUE`.

Note 6 `%MC_Stop_PTO.Done = TRUE` and `%MC_Stop_PTO.Execute = FALSE`.

The table describes the axis states:

State	Description
<i>Disabled</i>	Initial state of the axis, no motion command is allowed. The axis is not homed.
<i>Standstill</i>	Power is on, no error is detected, and no motion commands are active on the axis. Motion command is allowed.
<i>ErrorStop</i>	Highest priority, applicable when an error is detected on the axis or in the controller. Any ongoing move is aborted by a Fast Stop Deceleration . <i>Error</i> output is set to TRUE on applicable function blocks, and an <i>ErrorId</i> sets the error code. As long as an error is pending, the state remains <i>ErrorStop</i> . No further motion command is accepted until a reset has been done using <i>MC_Reset_PTO</i> .
<i>Homing</i>	Applicable when <i>MC_Home_PTO</i> controls the axis.
<i>Discrete</i>	Applicable when <i>MC_MoveRel_PTO</i> , <i>MC_MoveAbs_PTO</i> , or <i>MC_Halt_PTO</i> controls the axis.
<i>Continuous</i>	Applicable when <i>MC_MoveVel_PTO</i> controls the axis.
<i>Stopping</i>	Applicable when <i>MC_Stop_PTO</i> controls the axis.

NOTE: Function blocks which are not listed in the state diagram do not affect a change of state of the axis.

The entire motion command including acceleration and deceleration ramps cannot exceed 4,294,967,295 pulses. At the maximum frequency of 100 kHz, the acceleration and deceleration ramps are limited to 80 seconds.

Motion Transition Table

The PTO channel can respond to a new command while executing (and before completing) the current command according to the following table:

Command		Next					
		Home	MoveVel	MoveRel	MoveAbs	Halt	Stop
Current	Standstill	Allowed	Allowed ⁽¹⁾	Allowed ⁽¹⁾	Allowed ⁽¹⁾	Allowed	Allowed
	Home	Rejected	Rejected	Rejected	Rejected	Rejected	Allowed
	MoveVel	Rejected	Allowed	Allowed	Allowed	Allowed	Allowed
	MoveRel	Rejected	Allowed	Allowed	Allowed	Allowed	Allowed
	MoveAbs	Rejected	Allowed	Allowed	Allowed	Allowed	Allowed
	Halt	Rejected	Allowed	Allowed	Allowed	Allowed	Allowed
	Stop	Rejected	Rejected	Rejected	Rejected	Rejected	Rejected

⁽¹⁾ When the axis is at standstill, for the buffer modes *mcAborting*/*mcBuffered*/*mcBlendingPrevious*, the move starts immediately.

Allowed the new command begins execution even if the previous command has not completed execution.

Rejected the new command is ignored and results in the declaration of an error.

NOTE: When an error is detected in the motion transition, the axis goes into **ErrorStop** state. The *ErrorId* is set to *InvalidTransition*.

Buffer Mode

Description

Some of the motion function blocks have an input object called *BufferMode*. With this input object, the function block can either start immediately, start on probe event, or be buffered.

The available options are defined in the buffer modes function block object codes, page 101:

- An aborting motion (*mcAborting*) starts immediately, aborting any ongoing move, and clearing the motion queue.
- An event motion (*seTrigger*) is an aborting move, starting on probe event, page 80.
- A buffered motion (*mcBuffered*, *mcBlendingPrevious*, *seBufferedDelay*) is queued, that is, appended to any moves currently executing or waiting to execute, and starts when the previous motion is done.

Motion Queue Diagram

The figure illustrates the motion queue diagram:

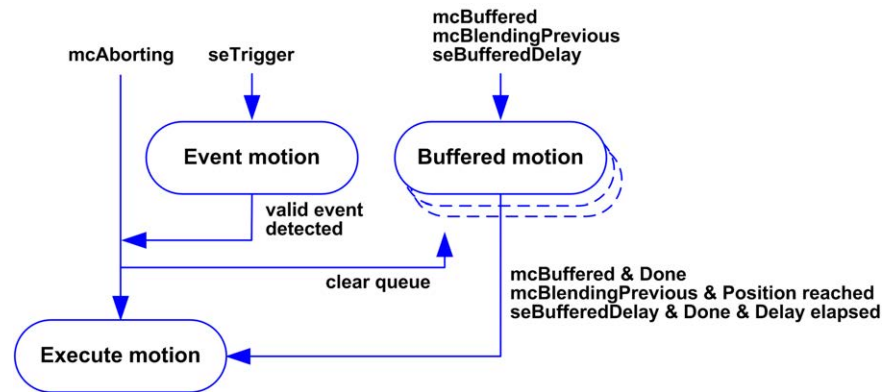

The buffer can contain only one motion function block.

The execution condition of the motion function block present in the buffer is:

- *mcBuffered*: when the current continuous motion is *InVel*, or when the current discrete motion stops.
- *seBufferedDelay*: when the specified delay has elapsed, from the current continuous motion is *InVel*, or from the current discrete motion stops.
- *mcBlendingPrevious*: when the position and velocity targets of current function block are reached.

The motion queue is cleared (all buffered motions are deleted):

- When an aborting move is triggered (*mcAborting* or *seTrigger*): *CmdAborted* output is set to TRUE on buffered function blocks.
- When a *MC_Stop_PTO* function is executed: *Error* output is set to TRUE on cleared buffered function blocks, with *ErrorId=StoppingActive*.
- When a transition to **ErrorStop** state is detected: *Error* output is set to TRUE on buffered function blocks, with *ErrorId=ErrorStopActive*.

NOTE:

- Only a valid motion can be queued. If the function block execution terminates with the *Error* output set to TRUE, the move is not queued, any move currently executing is not affected, and the queue is not cleared.
- When the queue is already full, the *Error* output is set to TRUE on the applicable function block, and *ErrorId* output returns the error *MotionQueueFull*.

Motion Function Blocks

Overview

This section describes the **Motion** function blocks.

MC_MotionTask_PTO Function Block

Function Description

Both single movement motion function blocks and the Motion Task Table function block (*MC_MotionTask_PTO*) can be used for an axis.

However, the *MC_MotionTask_PTO* function block cannot be executed concurrently with another motion function block. If so, an error is detected and the *ErrorId* is set to *InvalidTransitionMotionTask* (2009), page 103.

Graphical Representation

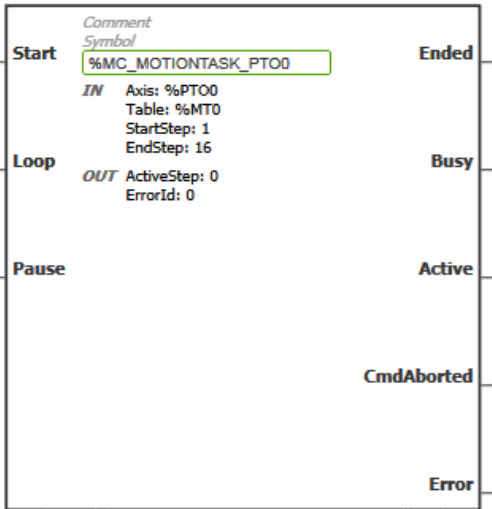

NOTE: When you first enter the function block, you must configure it to use the intended axis and motion task table. Double-click the function block to display the function block properties, choose the axis and table, then click **Apply**.

Inputs

This table describes the inputs of the function block:

Input	Initial Value	Description
<i>Start</i>	FALSE	<p>On rising edge, starts the function block execution.</p> <p>The <i>Loop</i> and <i>Pause</i> inputs can be changed during the function block execution and they affect the ongoing execution.</p> <p>The <i>Axis</i>, <i>Table</i>, <i>StartStep</i>, and <i>EndStep</i> input objects values define the motion sequence when the rising edge occurs. A subsequent change in these input objects does not affect the ongoing execution.</p> <p>The outputs are set when the function block execution terminates.</p> <p>When FALSE:</p> <ul style="list-style-type: none"> When the execution is ongoing (move is <i>Busy</i> and <i>Active</i>), outputs are refreshed. When the execution is terminated, the outputs are reset one cycle later.
<i>Loop</i>	FALSE	<p>When TRUE, once the function block execution terminates with no detected error, the motion task sequence starts again on <i>StartStep</i>. The <i>Ended</i> output is set for one cycle.</p> <p>The input is tested when the function block execution terminates with no detected error (<i>Ended</i> output is true).</p>
<i>Pause</i>	FALSE	<p>When TRUE:</p> <ul style="list-style-type: none"> <i>Active</i> = 1 and <i>Busy</i> = 1 Forces the axis to the Halt state. To reach the Halt state, the axis is decelerating in Discrete motion state, then the axis goes to the Standstill state when velocity = 0. The Halt state is kept as long as the <i>Pause</i> input is TRUE. Keeps the <i>Active</i> output set even if velocity is equal to 0. <p>When reset to FALSE after being set to TRUE, the motion task execution resumes in the following conditions:</p> <ul style="list-style-type: none"> The motion task resumes with the value of the ongoing velocity. The active step parameters are used. The absolute target position is not changed. If the motion task is a move relative type, there is no distance added. In the step, the Next step condition is reset (for example: the delay is restarted from 0, <i>Probe input event</i> is enabled and waiting for the configured edge).

This table describes the input objects of the function block:

Input Object	Type	Initial Value	Description
<i>Axis</i>	%PTOx	–	PTO axis instance for which the function block is to be executed. The parameter is set in the function block instance reached in the Programming > Tools module tab. Select the Axis parameter in PTO objects > Motion > MC_MotionTask_PTO > MC_MotionTask_PTO properties dialog box.
<i>Table</i>	%MT	–	Table instance for which the function block is to be executed. The parameter is set in the function block instance reached in the Programming > Tools module tab. Select the Table parameter in PTO objects > Motion > MC_MotionTask_PTO > MC_MotionTask_PTO properties dialog box.
<i>StartStep</i>	Byte	1	Step number that defines the first step executed in the Motion Task Table. The sequence is executed from <i>StartStep</i> to <i>EndStep</i> . Restriction: $StartStep \leq EndStep$.
<i>EndStep</i>	Byte	16	Step number that defines the last step executed in the Motion Task Table. The sequence is executed from <i>StartStep</i> to <i>EndStep</i> . Restriction: $StartStep \leq EndStep$. NOTE: If <i>EndStep</i> is greater than the maximum number of steps defined in the Motion Task Table, the last step of the table is used.

Outputs

This table describes the outputs of the function block:

Output	Initial Value	Description
<i>Ended</i>	0	When TRUE, function block execution is finished with no error detected. <i>Ended</i> output behavior: <ul style="list-style-type: none"> If the last step of the motion sequence is a discrete movement, the output behaves like a <i>Done</i> output, the other outputs (<i>Busy</i>, <i>Active</i>, <i>CmdAborted</i>, <i>Error</i>) are reset to 0. If the last step of the motion sequence is a continuous movement (move velocity), the output behaves like an <i>InVel</i> output. Other outputs behavior: <ul style="list-style-type: none"> <i>Busy</i> and <i>Active</i> are TRUE (1). <i>CmdAborted</i> and <i>Error</i> are FALSE (0). If a loop is requested (<i>Loop</i> input), the <i>Ended</i> output is TRUE for one task cycle.
<i>Busy</i>	-	When TRUE, function block execution is in progress. When FALSE, execution of the function block has been terminated.
<i>Active</i>	-	When TRUE, the function block instance has control of the axis. Only one function block at a time can set <i>Active</i> TRUE for the same axis.
<i>CmdAborted</i>	-	When TRUE, function block execution is terminated due to another motion command (<i>MC_Stop_PTO</i>) or an axis error detected.
<i>Error</i>	FALSE	If TRUE, indicates that an error was detected. Function block execution is finished.

This table describes the output objects of the function block:

Output Object	Type	Initial Value	Description
<i>ActiveStep</i>	Byte	0	Number of the step that is being executed in the Motion Task Table.
<i>ErrorId</i>	Word	<i>NoError</i>	Motion command error codes, valid when <i>Error</i> output is TRUE. Refer to PTO motion command error code table, page 103.

Operating Modes

The execution of a Motion Task Table called by *MC MotionTask PTO* function block complies with the motion state diagram, page 105.

MC_MotionTask_PTO start: The function block can only be started from **Standstill** state.

MC_MotionTask_PTO stop: The function block can be stopped by one of the following actions:

- Setting *Pause* input to TRUE.
- Executing a *MC_Stop_PTO*

Function block behavior on detected errors:

- If a motion state or range error is detected during the function block execution:
 - A motion stop command is applied to the motion task using the present step deceleration parameter value. If the step deceleration parameter is not valid, a fast stop deceleration is applied.
 - During the controlled motion stop, the function block outputs *Active* and *Busy* remain TRUE, with the output object *ActiveStep* = 0.
 - Once the motion is stopped, the function block execution is finished with *Error* = 1, and the *ErrorId* output object set to the value corresponding to the detected error type.
- If an axis control error is detected, the axis switches to the **ErrorStop** state. The function block execution is finished with *Error* = 1, and *ErrorId* = 2000.

MC_Power_PTO Function Block

Behavior

The axis is disabled, when:

- *%MC_Power_PTO.Enable* = FALSE, or
- *%MC_Power_PTO.DriveReady* = FALSE, or
- an Hardware limit error is detected (*HwPositionLimitP* / *HwPositionLimitN*)

When the axis is disabled, then:

- the Axis switches from *Standstill* to *Disabled* state, or from any ongoing move, to *ErrorStop*, and then *Disabled* state (when the error is reset).
- *%MC_ReadSts_PTO.IsHomed* is reset to 0 (a new homing procedure is required).

Graphical Representation

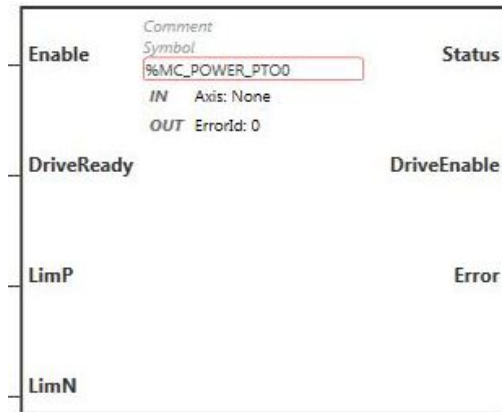

NOTE: When you first enter the function block, you must configure it to use the intended axis. Double-click on the function block to display the function block properties, choose the axis and click **Apply**.

Inputs

This table describes the inputs of the function block:

Input	Initial Value	Description
<i>Enable</i>	FALSE	When TRUE, the function block is executed. The values of the other function block inputs can be modified continuously, and the function block outputs are updated continuously. When FALSE, terminates the function block execution and resets its outputs.
<i>DriveReady</i>	FALSE	Signal from the drive indicating its readiness. Is set to TRUE when the drive is ready to start executing motion. If the drive signal is connected to the controller, use the appropriate controller input. If the drive does not provide this signal, you can force the value TRUE for this input with any TRUE boolean value.
<i>LimP</i>	TRUE	Hardware limit switch information, in positive direction. Is set to FALSE when the hardware limit switch is reached. If the hardware limit switch signal is connected to the controller, use the appropriate controller input. If this signal is not available, you can force the value TRUE for this input with any TRUE boolean value.
<i>LimN</i>	TRUE	Hardware limit switch information, in negative direction. Is set to FALSE when the hardware limit switch is reached. If the hardware limit switch signal is connected to the controller, use the appropriate controller input. If this signal is not available, you can force the value TRUE for this input with any TRUE boolean value.

This table describes the input object of the function block:

Input Object	Type	Initial Value	Description
<i>Axis</i>	PTOx	-	Instance for which the function block is to be executed. The name is declared in the controller configuration.

Outputs

This table describes the outputs of the function block:

Output	Initial Value	Description
<i>Status</i>	FALSE	When TRUE, the drive is reported as ready to accept motion commands.
<i>DriveEnable</i>	FALSE	When TRUE, indicates to the drive that it can accept motion commands and that it should, therefore, enable power. If the drive input is connected to the controller, use the appropriate controller output. If the drive does not have an input for this signal, you can leave this function block output unused.
<i>Error</i>	FALSE	If TRUE, indicates that an error was detected. Function block execution is finished.

This table describes the output object of the function block:

Output Object	Type	Initial Value	Description
<i>ErrorId</i>	Word	<i>NoError</i>	Motion command error codes, valid when <i>Error</i> output is TRUE. Refer to PTO motion command error code table, page 103.

Timing Diagram Example

The diagram illustrates the operation of the *MC_Power_PTO* function block:

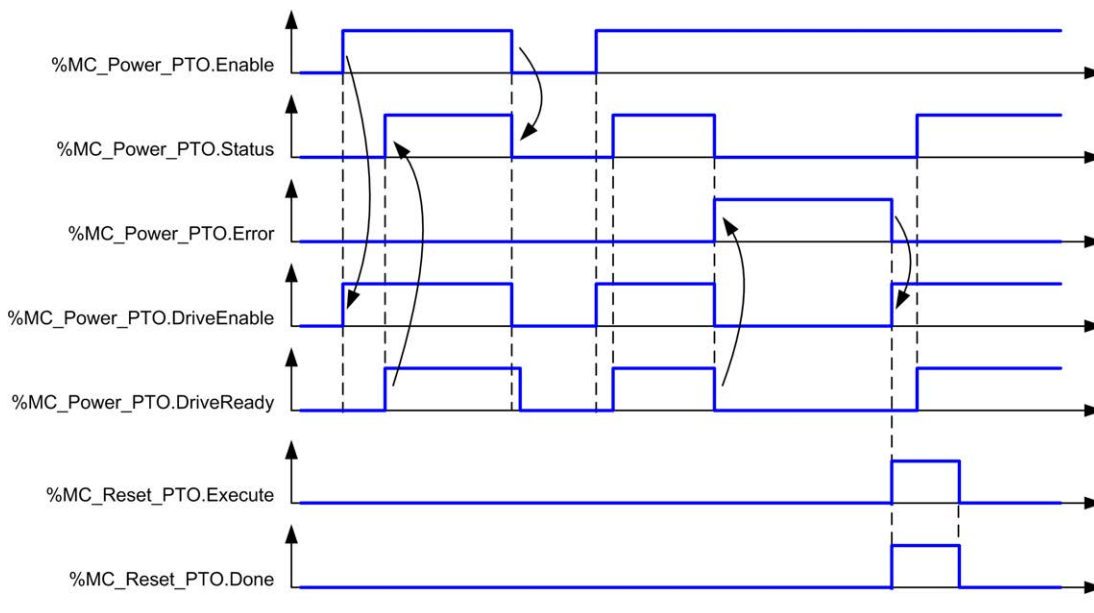

MC_MoveVel_PTO Function Block

Graphical Representation

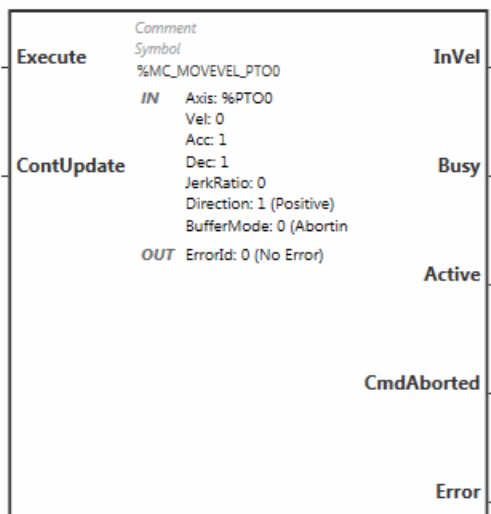

NOTE: When you first enter the function block, you must configure it to use the intended axis. Double-click on the function block to display the function block properties, choose the axis and click **Apply**.

Inputs

This table describes the inputs of the function block:

Input	Initial Value	Description
<i>Execute</i>	FALSE	<p>On rising edge, starts the function block execution. The values of the other function block inputs control the execution of the function block on the rising edge of <i>Execute</i>. A subsequent change in these input parameters does not affect the ongoing execution unless the <i>ContUpdate</i> input is TRUE.</p> <p>The outputs are set when the function block terminates.</p> <p>If a second rising edge is detected during the execution of the function block, the current execution is aborted and the function block is executed again.</p>
<i>ContUpdate</i>	FALSE	<p>When TRUE, makes the function block use any modified values of the input objects (<i>Vel</i>, <i>Acc</i>, <i>Dec</i>, and <i>Direction</i>), and apply it to the ongoing command.</p> <p>This input must be TRUE prior to the rising edge on the <i>Execute</i> input to be taken into account.</p> <p>NOTE: A modification to the value of the <i>Axis</i> parameter is not taken into account. You must set <i>Execute</i> to 0 and then to 1 to change the <i>Axis</i>.</p>

This table describes the input objects of the function block:

Input Object	Type	Initial Value	Description
<i>Axis</i>	PTOx	-	Instance for which the function block is to be executed. The name is declared in the controller configuration.
<i>Vel</i>	DINT	0	Target velocity. Range Hz: 0... <i>MaxVelocityAppl</i> , page 101
<i>Acc</i>	DINT	0	Acceleration in Hz/ms Range (Hz/ms): 1... <i>MaxAccelerationAppl</i> , page 101
<i>Dec</i>	DINT	0	Deceleration in Hz/ms Range (Hz/ms): 1... <i>MaxDecelerationAppl</i> , page 101
<i>JerkRatio</i>	INT	0	Percentage of acceleration / deceleration adjustment used to create the S-curve profile, page 79. Range: 0...100
<i>Direction</i>	INT	<i>mcPositiveDirection</i>	Direction of the movement for PTO type CW/CCW forward (CW) = 1 (<i>mcPositiveDirection</i>) reverse (CCW) = -1 (<i>mcNegativeDirection</i>)
<i>BufferMode</i>	INT	<i>mcA-borting</i>	Transition mode from ongoing move. Refer to Buffer Modes table, page 101.

Outputs

This table describes the outputs of the function block:

Output	Initial Value	Description
<i>InVel</i>	FALSE	When TRUE, the target velocity has been reached.
<i>Busy</i>	-	When TRUE, function block execution is in progress. When FALSE, execution of the function block has been terminated. The function block must be kept in an active task of the application program for at least as long as <i>Busy</i> is TRUE.
<i>Active</i>	-	When TRUE, the function block instance has control of the axis. Only one function block at a time can set <i>Active</i> TRUE for the same axis.
<i>CmdAborted</i>	-	When TRUE, function block execution is terminated due to another motion command.
<i>Error</i>	FALSE	If TRUE, indicates that an error was detected. Function block execution is finished.

This table describes the output object of the function block:

Output Object	Type	Initial Value	Description
<i>ErrorId</i>	Word	<i>NoError</i>	Motion command error codes, valid when <i>Error</i> output is TRUE. Refer to PTO motion command error code table, page 103.

NOTE:

- To stop the motion, the function block has to be interrupted by another function block issuing a new command.
- If a motion is ongoing, and the direction is reversed, first the motion is halted with the deceleration of the *MC_MoveVel_PTO* function block, and then the motion resumes backward.
- The acceleration/deceleration duration of the segment block must not exceed 80 seconds.

Timing Diagram Example

The diagram illustrates a simple profile from **Standstill** state:

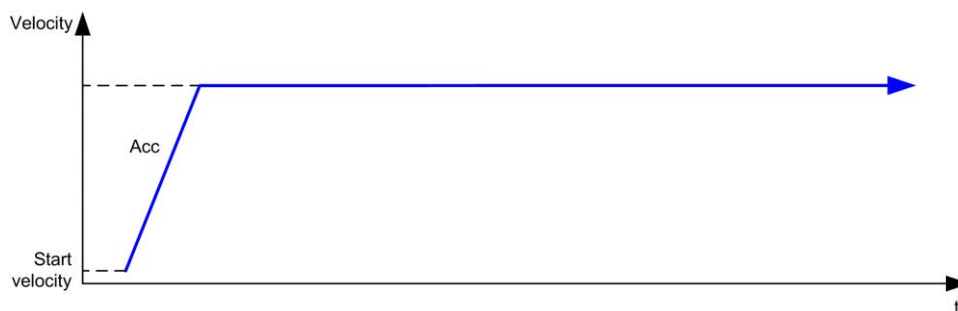

The diagram illustrates a complex profile from **Continuous** state:

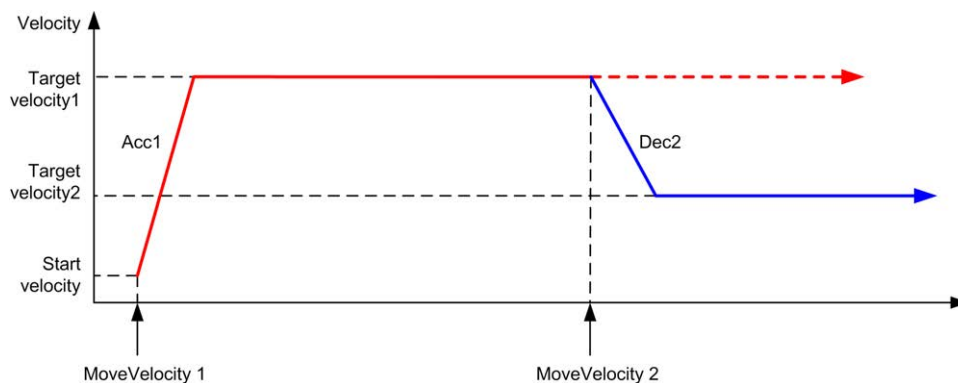

The diagram illustrates a complex profile from **Continuous** state with change of direction:

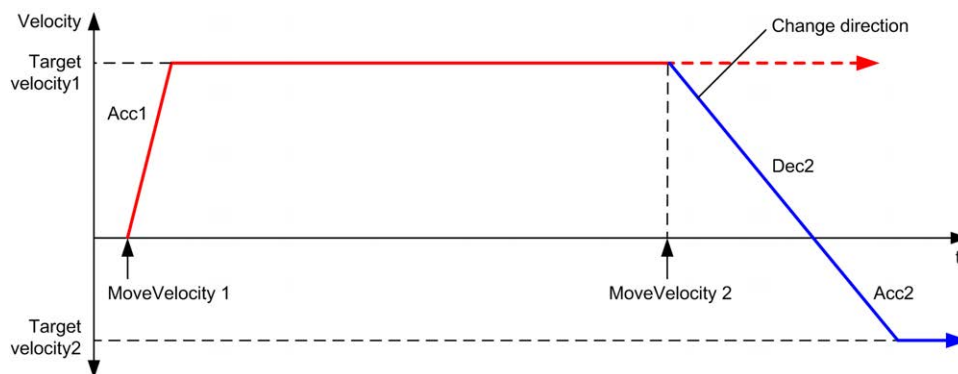

The diagram illustrates a complex profile from **Discrete** state:

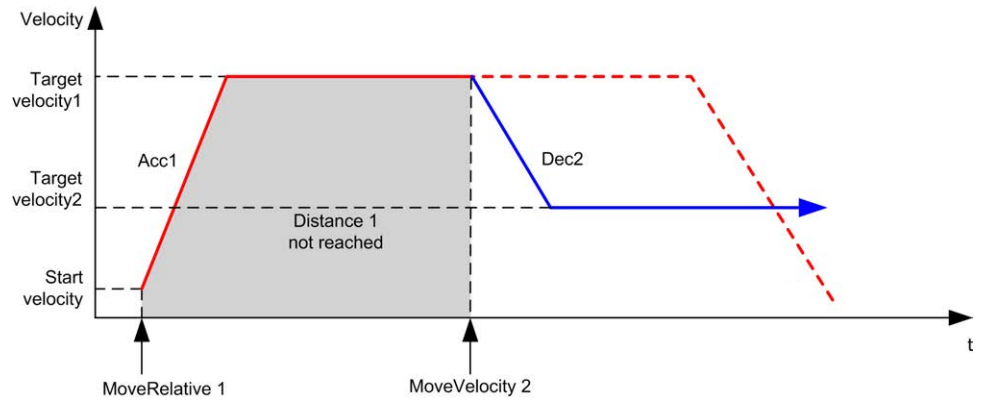

MC_MoveRel_PTO Function Block

Graphical Representation

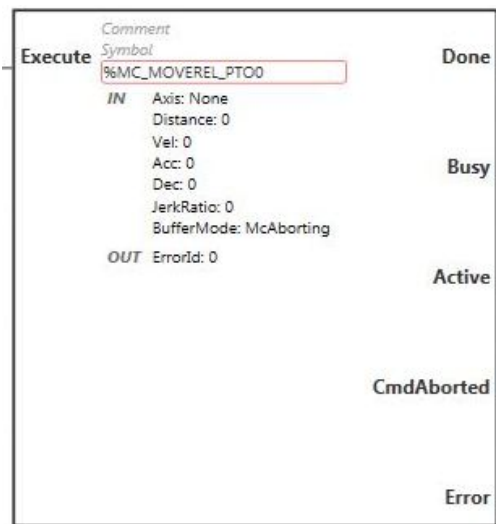

NOTE: When you first enter the function block, you must configure it to use the intended axis. Double-click on the function block to display the function block properties, choose the axis and click **Apply**.

Inputs

This table describes the input of the function block:

Input	Initial Value	Description
Execute	FALSE	On rising edge, starts the function block execution. The values of the other function block inputs control the execution of the function block on the rising edge of <i>Execute</i> . A subsequent change in these input parameters does not affect the ongoing execution. The outputs are set when the function block terminates.

This table describes the input objects of the function block:

Input Object	Type	Initial Value	Description
<i>Axis</i>	PTOx	-	Instance for which the function block is to be executed. The name is declared in the controller configuration.
<i>Distance</i>	DINT	0	Relative distance for the motion, in pulses. The sign specifies the direction.
<i>Vel</i>	DINT	0	Target velocity. Range Hz: 0... <i>MaxVelocityAppl</i> , page 101
<i>Acc</i>	DINT	0	Acceleration in Hz/ms Range (Hz/ms): 1... <i>MaxAccelerationAppl</i> , page 101
<i>Dec</i>	DINT	0	Deceleration in Hz/ms Range (Hz/ms): 1... <i>MaxDecelerationAppl</i> , page 101
<i>JerkRatio</i>	INT	0	Percentage of acceleration / deceleration adjustment used to create the S-curve profile, page 79. Range: 0...100
<i>BufferMode</i>	INT	<i>mcA-borting</i>	Transition mode from ongoing move. Refer to Buffer Modes table, page 101.

Outputs

This table describes the outputs of the function block:

Output	Initial Value	Description
<i>Done</i>	FALSE	When TRUE, function block execution is finished with no error detected. When one movement on an axis is interrupted with another movement on the same axis before the commanded action has been completed, <i>CmdAborted</i> is set to TRUE and <i>Done</i> is set to FALSE.
<i>Busy</i>	-	When TRUE, function block execution is in progress. When FALSE, execution of the function block has been terminated. The function block must be kept in an active task of the application program for at least as long as <i>Busy</i> is TRUE.
<i>Active</i>	-	When TRUE, the function block instance has control of the axis. Only one function block at a time can set <i>Active</i> TRUE for the same axis.
<i>CmdAborted</i>	-	When TRUE, function block execution is terminated due to another motion command.
<i>Error</i>	FALSE	If TRUE, indicates that an error was detected. Function block execution is finished.

This table describes the output object of the function block:

Output Object	Type	Initial Value	Description
<i>ErrorId</i>	Word	<i>NoError</i>	Motion command error codes, valid when <i>Error</i> output is TRUE. Refer to PTO motion command error code table, page 103.

NOTE:

- The function block completes with velocity zero if no further blocks are pending.
- If the distance is too short for the target velocity to be reached, the movement profile is triangular, rather than trapezoidal.
- If a motion is ongoing, and the commanded distance is exceeded due to the current motion parameters, the direction reversal is automatically managed: the motion is first halted with the deceleration of the *MC_MoveRel_PTO* function block, and then the motion resumes backward.
- The acceleration/deceleration duration of the segment block must not exceed 80 seconds.

Timing Diagram Example

The diagram illustrates a simple profile from **Standstill** state:

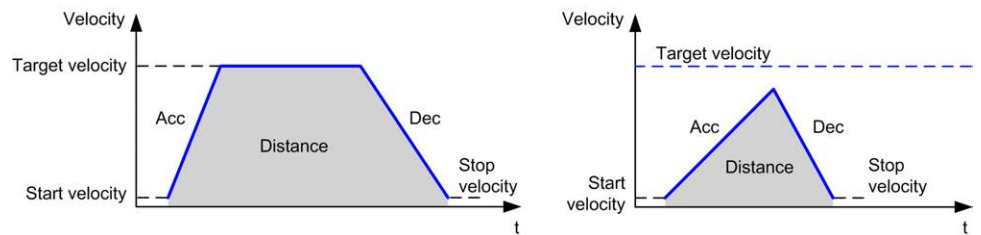

The diagram illustrates a complex profile from **Continuous** state:

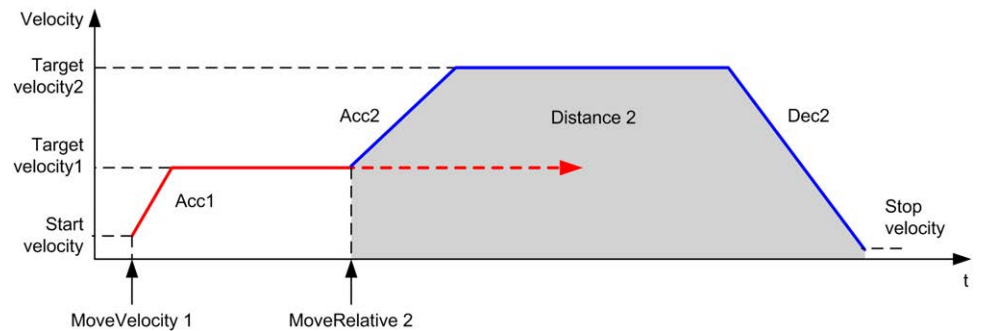

The diagram illustrates a complex profile from **Continuous** state with change of direction:

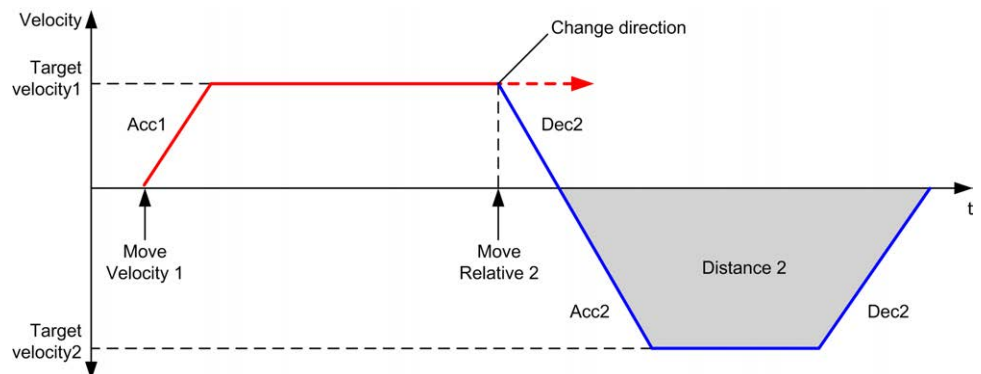

The diagram illustrates a complex profile from **Discrete** state:

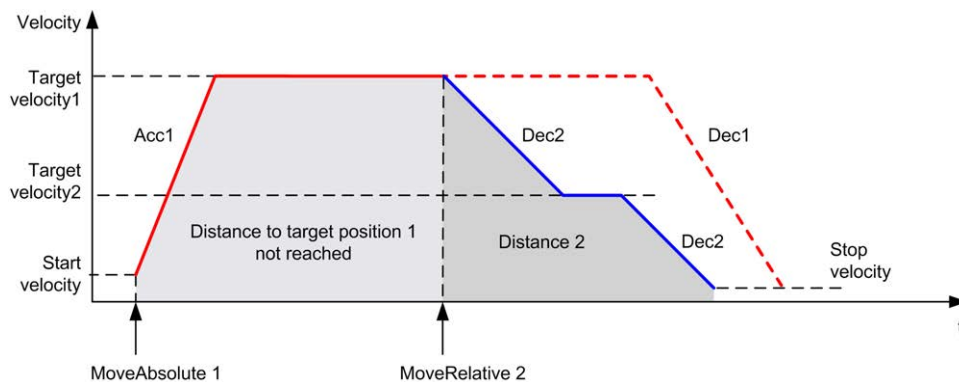

The diagram illustrates a complex profile from **Discrete** state with change of direction:

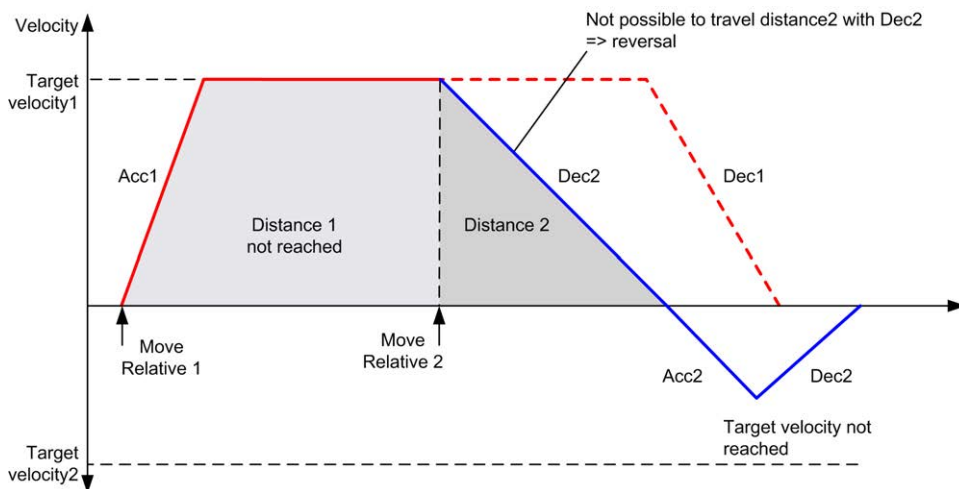

MC_MoveAbs_PTO Function Block

Graphical Representation



NOTE: When you first enter the function block, you must configure it to use the intended axis. Double-click on the function block to display the function block properties, choose the axis and click **Apply**.

Inputs

This table describes the input of the function block:

Input	Initial Value	Description
<i>Execute</i>	FALSE	On rising edge, starts the function block execution. The values of the other function block inputs control the execution of the function block on the rising edge of <i>Execute</i> . A subsequent change in these input parameters does not affect the ongoing execution. The outputs are set when the function block terminates.

This table describes the input objects of the function block:

Input Object	Type	Initial Value	Description
<i>Axis</i>	PTOx	-	Instance for which the function block is to be executed. The name is declared in the controller configuration.
<i>Pos</i>	DINT	0	Position of the axis.
<i>Vel</i>	DINT	0	Target velocity. Range Hz: 0... <i>MaxVelocityAppl</i> , page 101
<i>Acc</i>	DINT	0	Acceleration in Hz/ms Range (Hz/ms): 1... <i>MaxAccelerationAppl</i> , page 101
<i>Dec</i>	DINT	0	Deceleration in Hz/ms Range (Hz/ms): 1... <i>MaxDecelerationAppl</i> , page 101
<i>JerkRatio</i>	INT	0	Percentage of acceleration / deceleration adjustment used to create the S-curve profile, page 79. Range: 0...100
<i>BufferMode</i>	INT	<i>mCA-borting</i>	Transition mode from ongoing move. Refer to Buffer Modes table, page 101.

Outputs

This table describes the outputs of the function block:

Output	Initial Value	Description
<i>Done</i>	FALSE	When TRUE, function block execution is finished with no error detected. When one movement on an axis is interrupted with another movement on the same axis before the commanded action has been completed, <i>CmdAborted</i> is set to TRUE and <i>Done</i> is set to FALSE.
<i>Busy</i>	-	When TRUE, function block execution is in progress. When FALSE, execution of the function block has been terminated. The function block must be kept in an active task of the application program for at least as long as <i>Busy</i> is TRUE.
<i>Active</i>	-	When TRUE, the function block instance has control of the axis. Only one function block at a time can set <i>Active</i> TRUE for the same axis.
<i>CmdAborted</i>	-	When TRUE, function block execution is terminated due to another motion command.
<i>Error</i>	FALSE	If TRUE, indicates that an error was detected. Function block execution is finished.

This table describes the output object of the function block:

Output Object	Type	Initial Value	Description
<i>ErrorId</i>	Word	<i>NoError</i>	Motion command error codes, valid when <i>Error</i> output is TRUE. Refer to PTO motion command error code table, page 103.

NOTE:

- The function block completes with velocity zero if no further blocks are pending.
- The motion direction is automatically set, according to the current and target positions.
- If the distance is too short for the target velocity to be reached, the movement profile is triangular, rather than trapezoidal.
- If the position cannot be reached with the current direction, the direction reversal is automatically managed. If a motion is ongoing, it is first halted with the deceleration of the *MC_MoveAbsolute_PTO* function block, and then the motion resumes backward.
- The acceleration/deceleration duration of the segment block must not exceed 80 seconds.

Timing Diagram Example

The diagram illustrates a simple profile from **Standstill** state:

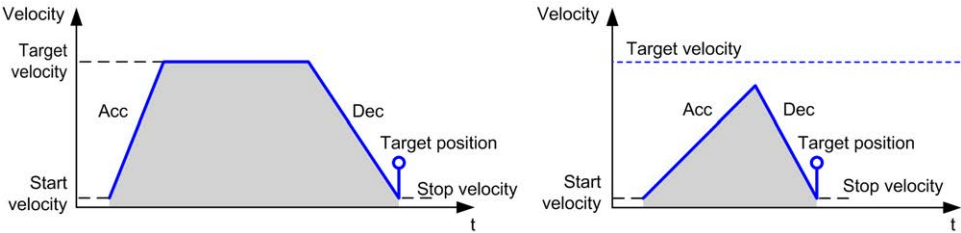

The diagram illustrates a complex profile from **Continuous** state:

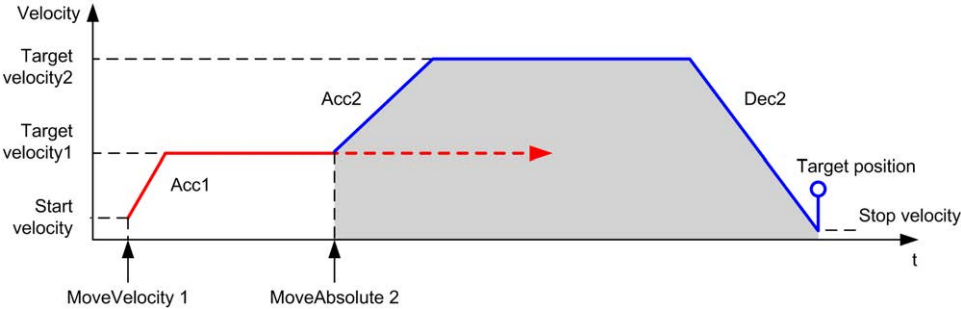

The diagram illustrates a complex profile from **Discrete** state:

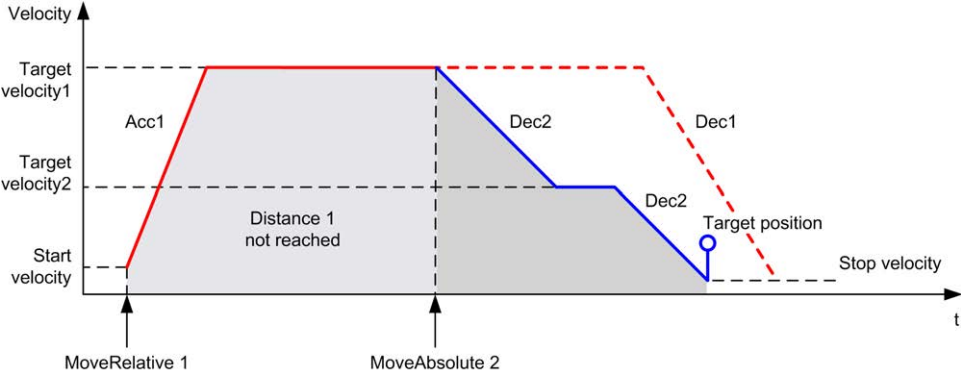

The diagram illustrates a complex profile from **Discrete** state with change of direction:

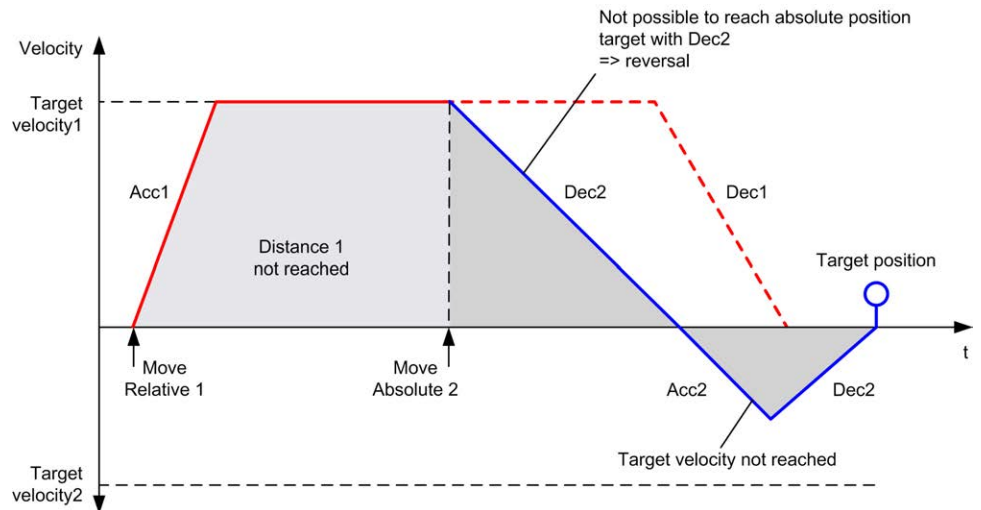

MC_Home_PTO Function Block

Graphical Representation

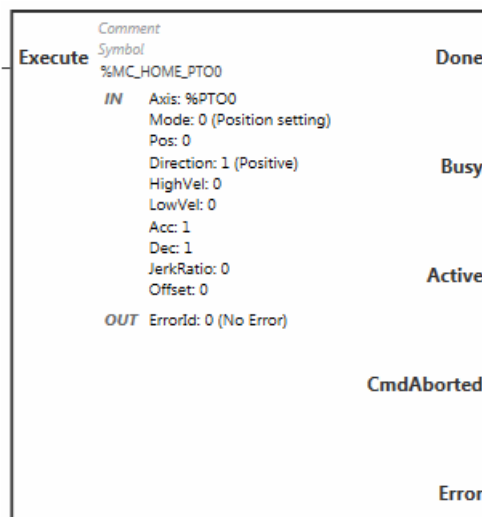

NOTE: When you first enter the function block, you must configure it to use the intended axis. Double-click on the function block to display the function block properties, choose the axis and click **Apply**.

Inputs

This table describes the input of the function block:

Input	Initial Value	Description
<i>Execute</i>	FALSE	On rising edge, starts the function block execution. The values of the other function block inputs control the execution of the function block on the rising edge of <i>Execute</i> . A subsequent change in these input parameters does not affect the ongoing execution. The outputs are set when the function block terminates.

This table describes the input objects of the function block:

Input Object	Type	Initial Value	Description
<i>Axis</i>	PTOx	-	Instance for which the function block is to be executed. The name is declared in the controller configuration.
<i>Mode</i>	BYTE	0	Predefined homing sequence type, page 101.
<i>Pos</i>	DINT	0	Position of the axis.
<i>HighVel</i>	DINT	0	Target homing velocity for searching the limit or reference switch. Range Hz: 1... <i>MaxVelocityAppl</i> , page 101
<i>LowVel</i>	DINT	0	Target homing velocity for searching the reference switch signal. The movement stops when the limit or reference switch is detected. Range Hz: 1... <i>HighVelocity</i>
<i>Acc</i>	DINT	0	Acceleration in Hz/ms Range (Hz/ms): 1... <i>MaxAccelerationAppl</i> , page 101
<i>Dec</i>	DINT	0	Deceleration in Hz/ms Range (Hz/ms): 1... <i>MaxDecelerationAppl</i> , page 101
<i>JerkRatio</i>	INT	0	Percentage of acceleration / deceleration adjustment used to create the S-curve profile, page 79. Range: 0...100
<i>Direction</i>	INT	<i>mcPositiveDirection</i>	Direction of the movement for PTO type CW/CCW forward (CW) = 1 (<i>mcPositiveDirection</i>) reverse (CCW) = -1 (<i>mcNegativeDirection</i>)
<i>Offset</i>	DINT	0	Distance from origin point. When the origin point is reached, the motion resumes until the distance is covered. Direction depends on the sign (Home offset, page 100). Range: -2,147,483,648...2,147,483,647

Outputs

This table describes the outputs of the function block:

Output	Initial Value	Description
<i>Done</i>	FALSE	When TRUE, function block execution is finished with no error detected. When one movement on an axis is interrupted with another movement on the same axis before the commanded action has been completed, <i>CmdAborted</i> is set to TRUE and <i>Done</i> is set to FALSE.
<i>Busy</i>	-	When TRUE, function block execution is in progress. When FALSE, execution of the function block has been terminated. The function block must be kept in an active task of the application program for at least as long as <i>Busy</i> is TRUE.
<i>Active</i>	-	When TRUE, the function block instance has control of the axis. Only one function block at a time can set <i>Active</i> TRUE for the same axis.
<i>CmdAborted</i>	-	When TRUE, function block execution is terminated due to another motion command.
<i>Error</i>	FALSE	If TRUE, indicates that an error was detected. Function block execution is finished.

This table describes the output object of the function block:

Output Object	Type	Initial Value	Description
<i>ErrorId</i>	Word	<i>NoError</i>	Motion command error codes, valid when <i>Error</i> output is TRUE. Refer to PTO motion command error code table, page 103.

NOTE: The acceleration/deceleration duration of the segment block must not exceed 80 seconds.

Timing Diagram Example

Home modes, page 94

MC_SetPos_PTO Function Block

Behavior

This function block modifies the coordinates of the actual position of the axis without any physical movement. It can only be used when the axis is in a *Standstill* state.

Graphical Representation



NOTE: When you first enter the function block, you must configure it to use the intended axis. Double-click on the function block to display the function block properties, choose the axis and click **Apply**.

Inputs

This table describes the input of the function block:

Input	Initial Value	Description
<i>Execute</i>	FALSE	On rising edge, starts the function block execution. The values of the other function block inputs control the execution of the function block on the rising edge of <i>Execute</i> . A subsequent change in these input parameters does not affect the ongoing execution. The outputs are set when the function block terminates.

This table describes the input objects of the function block:

Input Object	Type	Initial Value	Description
<i>Axis</i>	PTOx	-	Instance for which the function block is to be executed. The name is declared in the controller configuration.
<i>Pos</i>	DINT	0	Position of the axis.

Outputs

This table describes the outputs of the function block:

Output	Initial Value	Description
<i>Done</i>	FALSE	When TRUE, function block execution is finished with no error detected.
<i>Error</i>	FALSE	If TRUE, indicates that an error was detected. Function block execution is finished.

This table describes the output object of the function block:

Output Object	Type	Initial Value	Description
<i>ErrorId</i>	Word	<i>NoError</i>	Motion command error codes, valid when <i>Error</i> output is TRUE. Refer to PTO motion command error code table, page 103.

MC_Stop_PTO Function Block

Graphical Representation

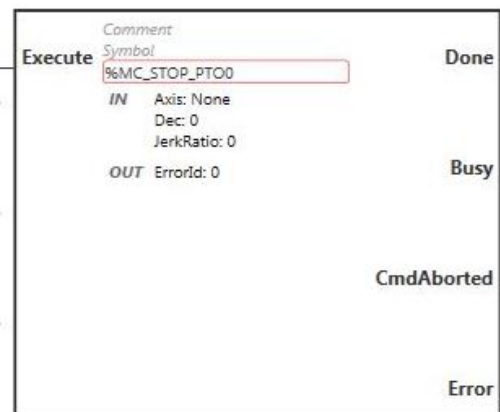

NOTE: When you first enter the function block, you must configure it to use the intended axis. Double-click on the function block to display the function block properties, choose the axis and click **Apply**.

Inputs

This table describes the input of the function block:

Input	Initial Value	Description
<i>Execute</i>	FALSE	On rising edge, starts the function block execution. The values of the other function block inputs control the execution of the function block on the rising edge of <i>Execute</i> . A subsequent change in these input parameters does not affect the ongoing execution. The outputs are set when the function block terminates.

This table describes the input objects of the function block:

Input Object	Type	Initial Value	Description
<i>Axis</i>	PTOx	-	Instance for which the function block is to be executed. The name is declared in the controller configuration.
<i>Dec</i>	DINT	0	Deceleration in Hz/ms Range (Hz/ms): 1... <i>MaxDecelerationAppl</i> , page 101
<i>JerkRatio</i>	INT	0	Percentage of acceleration / deceleration adjustment used to create the S-curve profile, page 79. Range: 0...100

Outputs

This table describes the outputs of the function block:

Output	Initial Value	Description
<i>Done</i>	FALSE	When TRUE, function block execution is finished with no error detected. When one movement on an axis is interrupted with another movement on the same axis before the commanded action has been completed, <i>CmdAborted</i> is set to TRUE and <i>Done</i> is set to FALSE.
<i>Busy</i>	-	When TRUE, function block execution is in progress. When FALSE, execution of the function block has been terminated. The function block must be kept in an active task of the application program for at least as long as <i>Busy</i> is TRUE.
<i>CmdAborted</i>	-	When TRUE, function block execution is terminated due to another motion command.
<i>Error</i>	FALSE	If TRUE, indicates that an error was detected. Function block execution is finished.

This table describes the output object of the function block:

Output Object	Type	Initial Value	Description
<i>ErrorId</i>	Word	<i>NoError</i>	Motion command error codes, valid when <i>Error</i> output is TRUE. Refer to PTO motion command error code table, page 103.

NOTE:

- Calling this function block in state **Standstill** changes the state to **Stopping**, and back to **Standstill** when *Execute* is FALSE.
- The state **Stopping** is kept as long as the input *Execute* is TRUE.
- The *Done* output is set when the stop ramp is finished.
- If *Deceleration* = 0, the fast stop deceleration is used.
- The function block completes with velocity zero.
- The deceleration duration of the segment block must not exceed 80 seconds.

Timing Diagram Example

The diagram illustrates a simple profile from **Continuous** state:

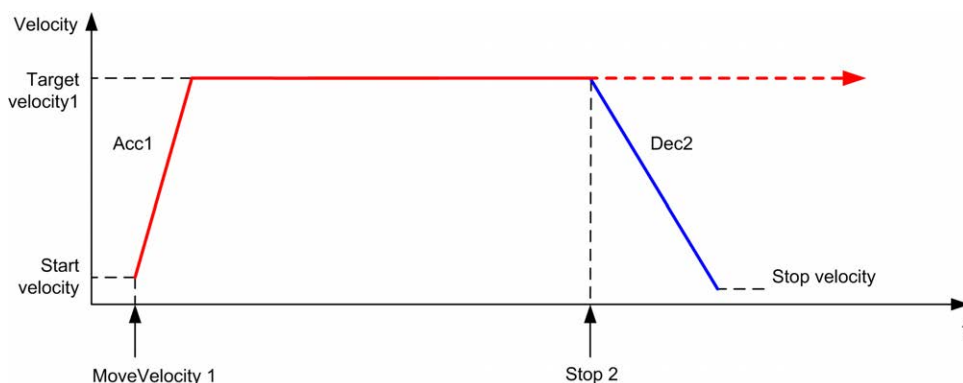

The diagram illustrates a simple profile from **Discrete** state:

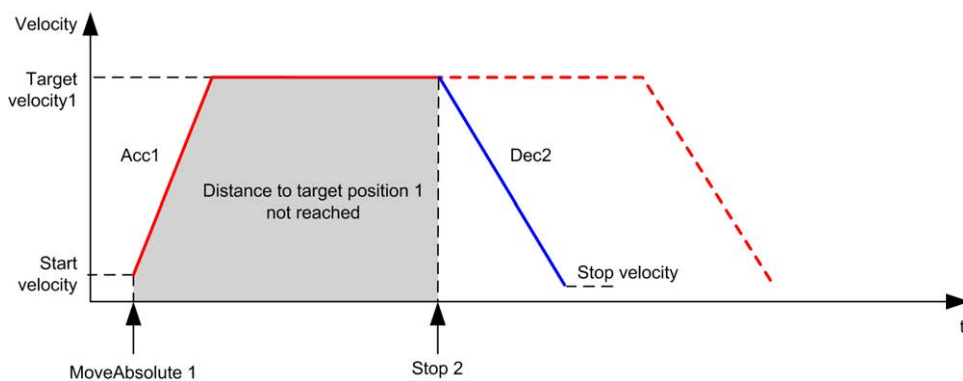

MC_Halt_PTO Function Block

Graphical Representation

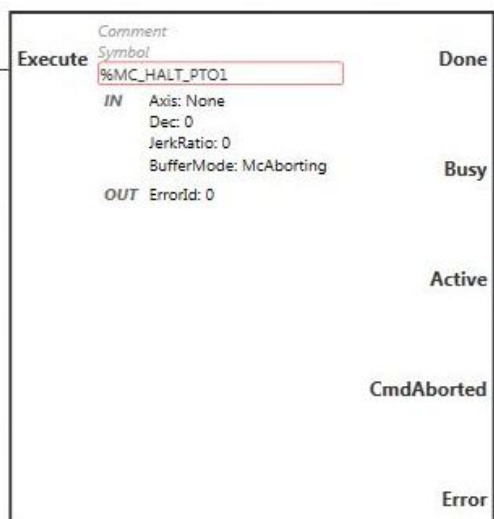

NOTE: When you first enter the function block, you must configure it to use the intended axis. Double-click on the function block to display the function block properties, choose the axis and click **Apply**.

Inputs

This table describes the input of the function block:

Input	Initial Value	Description
<i>Execute</i>	FALSE	On rising edge, starts the function block execution. The values of the other function block inputs control the execution of the function block on the rising edge of <i>Execute</i> . A subsequent change in these input parameters does not affect the ongoing execution. The outputs are set when the function block terminates.

This table describes the input objects of the function block:

Input Object	Type	Initial Value	Description
<i>Axis</i>	PTOx	-	Instance for which the function block is to be executed. The name is declared in the controller configuration.
<i>Dec</i>	DINT	0	Deceleration in Hz/ms Range (Hz/ms): 1... <i>MaxDecelerationAppl</i> , page 101
<i>JerkRatio</i>	INT	0	Percentage of acceleration / deceleration adjustment used to create the S-curve profile, page 79. Range: 0...100
<i>BufferMode</i>	INT	<i>mCA-borting</i>	Transition mode from ongoing move. Refer to Buffer Modes table, page 101.

Outputs

This table describes the outputs of the function block:

Output	Initial Value	Description
<i>Done</i>	FALSE	When TRUE, function block execution is finished with no error detected. When one movement on an axis is interrupted with another movement on the same axis before the commanded action has been completed, <i>CmdAborted</i> is set to TRUE and <i>Done</i> is set to FALSE.
<i>Busy</i>	-	When TRUE, function block execution is in progress. When FALSE, execution of the function block has been terminated. The function block must be kept in an active task of the application program for at least as long as <i>Busy</i> is TRUE.
<i>Active</i>	-	When TRUE, the function block instance has control of the axis. Only one function block at a time can set <i>Active</i> TRUE for the same axis.
<i>CmdAborted</i>	-	When TRUE, function block execution is terminated due to another motion command.
<i>Error</i>	FALSE	If TRUE, indicates that an error was detected. Function block execution is finished.

This table describes the output object of the function block:

Output Object	Type	Initial Value	Description
<i>ErrorId</i>	Word	<i>NoError</i>	Motion command error codes, valid when <i>Error</i> output is TRUE. Refer to PTO motion command error code table, page 103.

NOTE: The function block completes with velocity zero.

Timing Diagram Example

The diagram illustrates a simple profile from **Continuous** state:

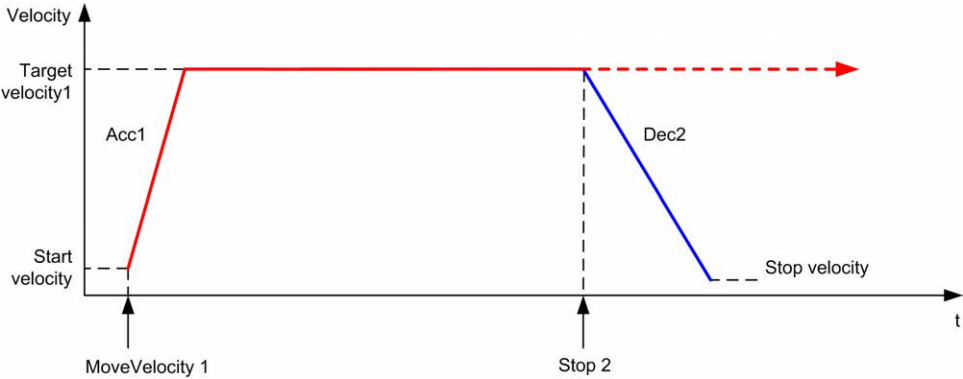

The diagram illustrates a simple profile from **Discrete** state:

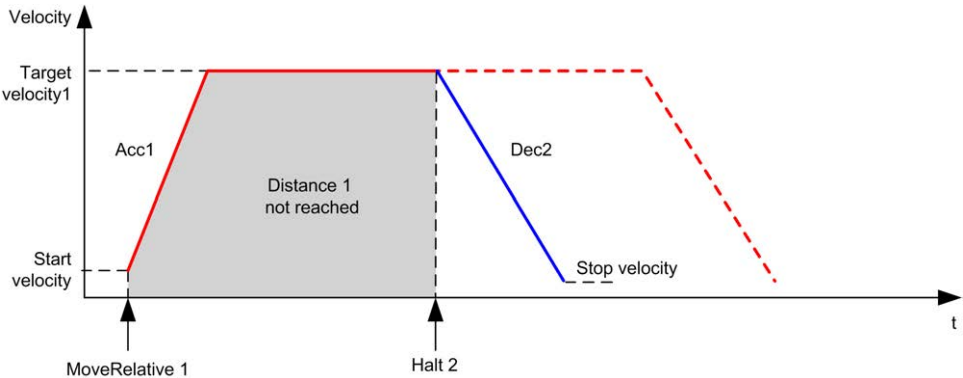

Administrative Function Blocks

Overview

This section describes the **Administrative** function blocks.

MC_ReadActVel_PTO Function Block

Function Description

This function block returns the value of the actual velocity of the axis.

Graphical Representation

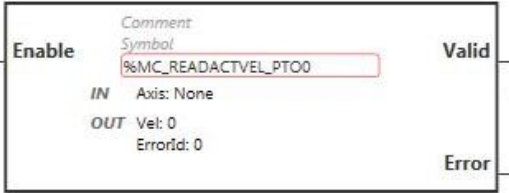

NOTE: When you first enter the function block, you must configure it to use the intended axis. Double-click on the function block to display the function block properties, choose the axis and click **Apply**.

Inputs

This table describes the input of the function block:

Input	Initial Value	Description
<i>Enable</i>	FALSE	When TRUE, the function block is executed. The values of the other function block inputs can be modified continuously, and the function block outputs are updated continuously. When FALSE, terminates the function block execution and resets its outputs.

This table describes the input object of the function block:

Input Object	Type	Initial Value	Description
<i>Axis</i>	PTOx	-	Instance for which the function block is to be executed. The name is declared in the controller configuration.

Outputs

This table describes the outputs of the function block:

Output	Initial Value	Description
<i>Valid</i>	-	If TRUE, the function block object data is valid.
<i>Error</i>	FALSE	If TRUE, indicates that an error was detected. Function block execution is finished.

This table describes the output objects of the function block:

Output Object	Type	Initial Value	Description
<i>Vel</i>	DINT	-	Velocity of the axis.
<i>ErrorId</i>	Word	<i>NoError</i>	Motion command error codes, valid when <i>Error</i> output is TRUE. Refer to PTO motion command error code table, page 103.

MC_ReadActPos_PTO Function Block

Function Description

This function block returns the value of the actual position of the axis.

Graphical Representation



NOTE: When you first enter the function block, you must configure it to use the intended axis. Double-click on the function block to display the function block properties, choose the axis and click **Apply**.

Inputs

This table describes the input of the function block:

Input	Initial Value	Description
<i>Enable</i>	FALSE	When TRUE, the function block is executed. The values of the other function block inputs can be modified continuously, and the function block outputs are updated continuously. When FALSE, terminates the function block execution and resets its outputs.

This table describes the input object of the function block:

Input Object	Type	Initial Value	Description
<i>Axis</i>	PTOx	-	Instance for which the function block is to be executed. The name is declared in the controller configuration.

Outputs

This table describes the outputs of the function block:

Output	Initial Value	Description
<i>Valid</i>	-	If TRUE, the function block object data is valid.
<i>Error</i>	FALSE	If TRUE, indicates that an error was detected. Function block execution is finished.

This table describes the output objects of the function block:

Output Object	Type	Initial Value	Description
<i>Pos</i>	DINT	-	Position of the axis.
<i>ErrorId</i>	Word	<i>NoError</i>	Motion command error codes, valid when <i>Error</i> output is TRUE. Refer to PTO motion command error code table, page 103.

MC_ReadSts_PTO Function Block

Function Description

This function block returns the state diagram status of the axis.

Graphical Representation



NOTE: When you first enter the function block, you must configure it to use the intended axis. Double-click on the function block to display the function block properties, choose the axis and click **Apply**.

Inputs

This table describes the input of the function block:

Input	Initial Value	Description
<i>Enable</i>	FALSE	When TRUE, the function block is executed. The values of the other function block inputs can be modified continuously, and the function block outputs are updated continuously. When FALSE, terminates the function block execution and resets its outputs.

This table describes the input object of the function block:

Input Object	Type	Initial Value	Description
<i>Axis</i>	PTOx	-	Instance for which the function block is to be executed. The name is declared in the controller configuration.

Outputs

This table describes the outputs of the function block:

Output	Initial Value	Description
<i>Valid</i>	-	If TRUE, the function block object data is valid.
<i>Error</i>	FALSE	If TRUE, indicates that an error was detected. Function block execution is finished.
<i>IsHomed</i>	FALSE	When TRUE, it indicates that the axis has been homed such that the absolute reference point is valid, and absolute motion commands are allowed.
<i>AxisWarning</i>	FALSE	When TRUE, an alert or an advisory has been provoked by a motion command. Use <i>MC_ReadAxisError_PTO</i> function block to obtain detailed information., page 136
<i>QueueFull</i>	FALSE	When TRUE, the motion queue is full and no additional buffered motion commands are allowed.

This table describes the output objects of the function block:

Output Object	Type	Initial Value	Description
<i>AxisState</i>	-	-	Code for the state of the axis: 0 = axis not configured 1 = ErrorStop 2 = Disabled 4 = Stopping 8 = Homing 16 = Standstill 32 = Discrete motion 64 = Continuous motion For more information, refer to the States description table, page 105.
<i>ErrorId</i>	Word	<i>NoError</i>	Motion command error codes, valid when <i>Error</i> output is TRUE. Refer to PTO motion command error code table, page 103.

MC_ReadMotionState_PTO Function Block

Function Description

This function block returns the actual motion status of the axis.

Graphical Representation

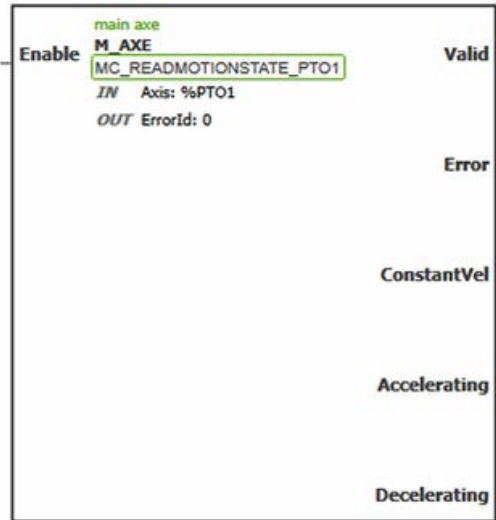

NOTE: When you first enter the function block, you must configure it to use the intended axis. Double-click on the function block to display the function block properties, choose the axis and click **Apply**.

Inputs

This table describes the input of the function block:

Input	Initial Value	Description
<i>Enable</i>	FALSE	When TRUE, the function block is executed. The values of the other function block inputs can be modified continuously, and the function block outputs are updated continuously. When FALSE, terminates the function block execution and resets its outputs.

This table describes the input object of the function block:

Input Object	Type	Initial Value	Description
<i>Axis</i>	PTOx	-	Instance for which the function block is to be executed. The name is declared in the controller configuration.

Outputs

This table describes the outputs of the function block:

Output	Initial Value	Description
<i>Valid</i>	-	If TRUE, the function block object data is valid.
<i>Error</i>	FALSE	If TRUE, indicates that an error was detected. Function block execution is finished.
<i>ConstantVel</i>	-	When TRUE, the velocity of the axis is constant.
<i>Accelerating</i>	-	When TRUE, the velocity of the axis is increasing.
<i>Decelerating</i>	-	When TRUE, the velocity of the axis is decreasing.

This table describes the output object of the function block:

Output Object	Type	Initial Value	Description
<i>ErrorId</i>	Word	<i>NoError</i>	Motion command error codes, valid when <i>Error</i> output is TRUE. Refer to PTO motion command error code table, page 103.

MC_ReadAxisError_PTO Function Block

Function Description

This function block retrieves the axis control error. If no axis control error is pending, the function block returns *AxisErrorId* = 0.

Graphical Representation

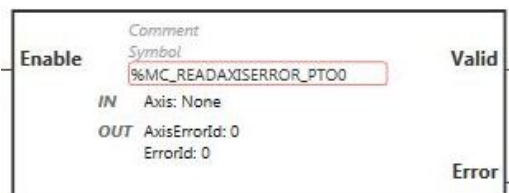

NOTE: When you first enter the function block, you must configure it to use the intended axis. Double-click on the function block to display the function block properties, choose the axis and click **Apply**.

Inputs

This table describes the input of the function block:

Input	Initial Value	Description
<i>Enable</i>	FALSE	When TRUE, the function block is executed. The values of the other function block inputs can be modified continuously, and the function block outputs are updated continuously. When FALSE, terminates the function block execution and resets its outputs.

This table describes the input object of the function block:

Input Object	Type	Initial Value	Description
<i>Axis</i>	PTOx	-	Instance for which the function block is to be executed. The name is declared in the controller configuration.

Outputs

This table describes the outputs of the function block:

Output	Initial Value	Description
<i>Valid</i>	-	If TRUE, the function block object data is valid.
<i>Error</i>	FALSE	If TRUE, indicates that an error was detected. Function block execution is finished.

This table describes the output objects of the function block:

Output Object	Type	Initial Value	Description
<i>AxisErrorId</i>	-	-	Axis error codes, valid when <i>AxisWarning</i> output is TRUE. Refer to PTO axis error code table, page 102.
<i>ErrorId</i>	Word	<i>NoError</i>	Motion command error codes, valid when <i>Error</i> output is TRUE. Refer to PTO motion command error code table, page 103.

MC_Reset_PTO Function Block

Behavior

This function block resets all axis-related errors, conditions permitting, to allow a transition from the states **ErrorStop** to **Standstill**. It does not affect the output of the function blocks instances.

Graphical Representation

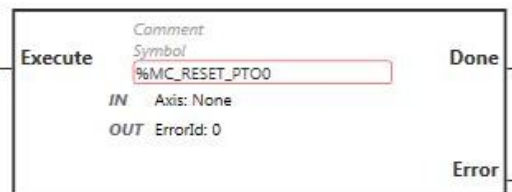

NOTE: When you first enter the function block, you must configure it to use the intended axis. Double-click on the function block to display the function block properties, choose the axis and click **Apply**.

Inputs

This table describes the input of the function block:

Input	Initial Value	Description
<i>Execute</i>	FALSE	On rising edge, starts the function block execution. The values of the other function block inputs control the execution of the function block on the rising edge of <i>Execute</i> . A subsequent change in these input parameters does not affect the ongoing execution. The outputs are set when the function block terminates.

This table describes the input object of the function block:

Input Object	Type	Initial Value	Description
<i>Axis</i>	PTOx	-	Instance for which the function block is to be executed. The name is declared in the controller configuration.

Outputs

This table describes the outputs of the function block:

Output	Initial Value	Description
<i>Done</i>	FALSE	When TRUE, function block execution is finished with no error detected.
<i>Error</i>	FALSE	If TRUE, indicates that an error was detected. Function block execution is finished.

This table describes the output object of the function block:

Output Object	Type	Initial Value	Description
<i>ErrorId</i>	Word	<i>NoError</i>	Motion command error codes, valid when <i>Error</i> output is TRUE. Refer to PTO motion command error code table, page 103.

MC_TouchProbe_PTO Function Block

Function Description

This function block is used to activate a trigger event on the probe input. This trigger event allows to record the axis position, and/or to start a buffered move.

Graphical Representation

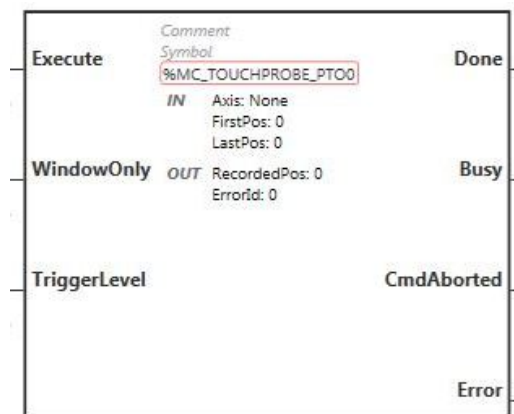

NOTE: When you first enter the function block, you must configure it to use the intended axis. Double-click on the function block to display the function block properties, choose the axis and click **Apply**.

Inputs

This table describes the inputs of the function block:

Input	Initial Value	Description
<i>Execute</i>	FALSE	On rising edge, starts the function block execution. The values of the other function block inputs control the execution of the function block on the rising edge of <i>Execute</i> . A subsequent change in these input parameters does not affect the ongoing execution. The outputs are set when the function block terminates. If a second rising edge is detected during the execution of the function block, the current execution is aborted and the function block is executed again. If the <i>Execute</i> input is subsequently set to 0, the axis position is recorded and the <i>Done</i> output set to 1 for one MAST cycle. The axis position is then reset and the <i>Done</i> output is set to 0.
<i>WindowOnly</i>	FALSE	When TRUE, a trigger event is only recognized within the position range (window) defined by <i>FirstPosition</i> and <i>LastPosition</i> .
<i>TriggerLevel</i>	FALSE	When TRUE, position captured or event triggered at rising edge. When FALSE, position captured or event triggered at falling edge.

This table describes the input objects of the function block:

Input Object	Type	Initial Value	Description
<i>Axis</i>	PTOx	-	Instance for which the function block is to be executed. The name is declared in the controller configuration.
<i>FirstPos</i>	DINT	0	Start of the absolute position from where trigger events are accepted (value included in enable window).
<i>LastPos</i>	DINT	0	End of the absolute position from which trigger events are accepted (value included in enable window).

Outputs

This table describes the outputs of the function block:

Output	Initial Value	Description
<i>Done</i>	FALSE	When TRUE, function block execution is finished with no error detected. When one movement on an axis is interrupted with another movement on the same axis before the commanded action has been completed, <i>CmdAborted</i> is set to TRUE and <i>Done</i> is set to FALSE.
<i>Busy</i>	-	When TRUE, function block execution is in progress. When FALSE, execution of the function block has been terminated. The function block must be kept in an active task of the application program for at least as long as <i>Busy</i> is TRUE.
<i>CmdAborted</i>	-	When TRUE, function block execution is terminated due to another motion command.
<i>Error</i>	FALSE	If TRUE, indicates that an error was detected. Function block execution is finished.

This table describes the output objects of the function block:

Output Object	Type	Initial Value	Description
<i>RecordedPos</i>	-	-	Position where trigger event was detected.
<i>ErrorId</i>	Word	<i>NoError</i>	Motion command error codes, valid when <i>Error</i> output is TRUE. Refer to PTO motion command error code table, page 103.

NOTE:

- Only one instance of this function block is allowed on the same axis.
- Only the first event after the rising edge at the *MC_TouchProbe_PTO* function block *Busy* output is valid. Once the *Done* output is set to TRUE, subsequent events are ignored. The function block needs to be reactivated to respond to other events.

MC_AbortTrigger_PTO Function Block

Function Description

This function block is used to abort function blocks which are connected to trigger events (for example, *MC_TouchProbe_PTO*).

Graphical Representation

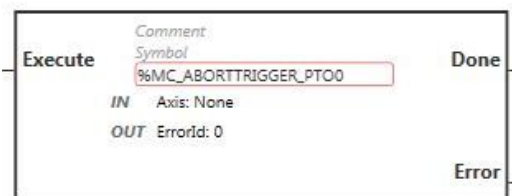

NOTE: When you first enter the function block, you must configure it to use the intended axis. Double-click on the function block to display the function block properties, choose the axis and click **Apply**.

Inputs

This table describes the input of the function block:

Input	Initial Value	Description
<i>Execute</i>	FALSE	On rising edge, starts the function block execution. The values of the other function block inputs control the execution of the function block on the rising edge of <i>Execute</i> . A subsequent change in these input parameters does not affect the ongoing execution. The outputs are set when the function block terminates.

This table describes the input object of the function block:

Input Object	Type	Initial Value	Description
<i>Axis</i>	PTOx	-	Instance for which the function block is to be executed. The name is declared in the controller configuration.

Outputs

This table describes the outputs of the function block:

Output	Initial Value	Description
<i>Done</i>	FALSE	When TRUE, function block execution is finished with no error detected.
<i>Error</i>	FALSE	If TRUE, indicates that an error was detected. Function block execution is finished.

This table describes the output object of the function block:

Output Object	Type	Initial Value	Description
<i>ErrorId</i>	Word	<i>NoError</i>	Motion command error codes, valid when <i>Error</i> output is TRUE. Refer to PTO motion command error code table, page 103.

MC_ReadPar_PTO Function Block

Function Description

This function block is used to get parameters from the PTO.

Graphical Representation

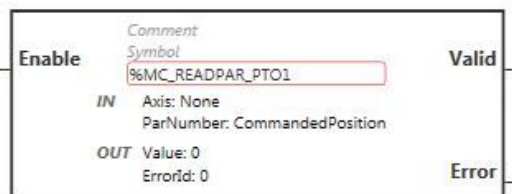

NOTE: When you first enter the function block, you must configure it to use the intended axis. Double-click on the function block to display the function block properties, choose the axis and click **Apply**.

Inputs

This table describes the input of the function block:

Input	Initial Value	Description
<i>Enable</i>	FALSE	When TRUE, the function block is executed. The values of the other function block inputs can be modified continuously, and the function block outputs are updated continuously. When FALSE, terminates the function block execution and resets its outputs.

This table describes the input objects of the function block:

Input Object	Type	Initial Value	Description
<i>Axis</i>	PTOx	-	Instance for which the function block is to be executed. The name is declared in the controller configuration.
<i>ParNumber</i>	DINT	0	Code for the parameter you wish to read or write. For more information, refer to PTO Parameter table, page 101.

Outputs

This table describes the outputs of the function block:

Output	Initial Value	Description
<i>Valid</i>	-	If TRUE, the function block object data is valid.
<i>Error</i>	FALSE	If TRUE, indicates that an error was detected. Function block execution is finished.

This table describes the output objects of the function block:

Output Object	Type	Initial Value	Description
<i>Value</i>	DINT	0	Value of the requested parameter.
<i>ErrorId</i>	Word	<i>NoError</i>	Motion command error codes, valid when <i>Error</i> output is TRUE. Refer to PTO motion command error code table, page 103.

MC_WritePar_PTO Function Block

Function Description

This function block is used to write parameters to the PTO.

Graphical Representation

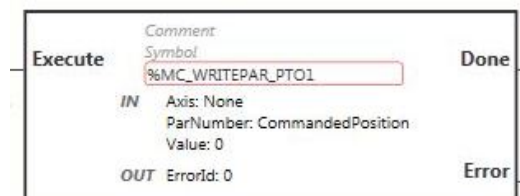

NOTE: When you first enter the function block, you must configure it to use the intended axis. Double-click on the function block to display the function block properties, choose the axis and click **Apply**.

Inputs

This table describes the input of the function block:

Input	Initial Value	Description
<i>Execute</i>	FALSE	On rising edge, starts the function block execution. The values of the other function block inputs control the execution of the function block on the rising edge of <i>Execute</i> . A subsequent change in these input parameters does not affect the ongoing execution. The outputs are set when the function block terminates.

This table describes the input objects of the function block:

Input Object	Type	Initial Value	Description
<i>Axis</i>	PTOx	-	Instance for which the function block is to be executed. The name is declared in the controller configuration.
<i>ParNumber</i>	DINT	0	Code for the parameter you wish to read or write. For more information, refer to PTO Parameter table, page 101.
<i>Value</i>	DINT	0	Value to be written to the parameter chosen with the <i>ParNumber</i> input object.

Outputs

This table describes the outputs of the function block:

Output	Initial Value	Description
<i>Done</i>	FALSE	When TRUE, function block execution is finished with no error detected.
<i>Error</i>	FALSE	If TRUE, indicates that an error was detected. Function block execution is finished.

This table describes the output object of the function block:

Output Object	Type	Initial Value	Description
<i>ErrorId</i>	Word	<i>NoError</i>	Motion command error codes, valid when <i>Error</i> output is TRUE. Refer to PTO motion command error code table, page 103.

Frequency Generator (%FREQGEN)

What's in This Chapter

Description 145
 Configuration 146

Description

Introduction

The frequency generator *FREQGEN* function block  commands a square wave signal output at a specified frequency.

The frequency is configurable from 0 Hz to 100 kHz with a 1 Hz step.

The *FREQGEN* function has the following characteristics:

Characteristic	Value
Number of channels	2 or 4, depending on the reference
Minimum frequency	0 Hz
Maximum frequency	100 kHz
Accuracy on frequency	1 %

Illustration

This illustration is a *FREQGEN* function block:

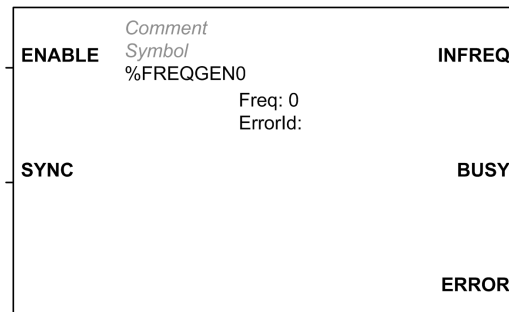

Inputs

This table describes the inputs of the function block:

Input	Initial Value	Description
ENABLE	FALSE	When TRUE, the function block is executed. The values of the other function block inputs can be modified continuously, and the function block outputs are updated continuously. When FALSE, terminates the function block execution and resets its outputs.
SYNC	FALSE	When a rising edge is detected, the target frequency is emitted without waiting for the end of the ongoing period output.

This table describes the input object of the function block:

Input Object	Type	Initial Value	Description
Freq	DWORD	-	Frequency of the <i>Frequency Generator</i> output signal in Hz. Specify the frequency in the <i>Pulse Generators</i> properties, page 147 table (Range: minimum 0 (0 Hz)...maximum 100000 (100 kHz))

Outputs

This table describes the outputs of the function block:

Output	Initial Value	Description
INFREQ	-	If TRUE, the frequency generator signal is being output at the frequency specified in the Freq input object.
BUSY	-	When TRUE, function block execution is in progress. When FALSE, execution of the function block has been terminated. The function block must be kept in an active task of the application program for at least as long as BUSY is TRUE.
ERROR	FALSE	If TRUE, indicates that an error was detected. Function block execution is finished.

This table describes the output object of the function block:

Output Object	Type	Initial Value	Description
ErrorId	Word	<i>NoError</i>	Error codes, valid when ERROR output is TRUE. Refer to the ErrorId Error Codes table below.

ErrorId Error Codes

This table lists the values for the function block error codes

Name	Value	Description
<i>NoError</i>	0	No errors detected.
<i>OutputProtection</i>	1007	The pulse output has a digital output protection active. Refer to system objects %S10 and %SW139 (see Modicon M221, Logic Controller, Programming Guide) for more details.
<i>OutputReset</i>	1008	%S9 forced all outputs to be set to 0. Refer to System Bits (see Modicon M221, Logic Controller, Programming Guide).
<i>InvalidFrequencyValue</i>	3002	The frequency Freq input object is outside the allowed range.

Configuration

Overview

To configure the *Pulse Generator* resource, refer to *Configuring Pulse Generators* (see Modicon M221, Logic Controller, Programming Guide).

To configure the *Pulse Generator* resource as a *FREQGEN*, refer to Configuring Frequency Generator (see Modicon M221, Logic Controller, Programming Guide).

Properties

The *FREQGEN* function block has the following properties:

Property	Description	Value
Used	Address used	If selected, this address is in use in a program.
Address	%FREQGENi Frequency generator address	The instance identifier, where i is from 0 to the number of objects available on this logic controller. For the maximum number of <i>FREQGEN</i> objects, refer to the table Maximum Number of Objects (see Modicon M221, Logic Controller, Programming Guide).
Symbol	Symbol	The symbol associated with this object. For details, refer to Defining and Using Symbols (see EcoStruxure Machine Expert - Basic, Operating Guide).
Freq	Frequency	The frequency of the frequency generator output signal in Hz. Minimum value: 0 (0 Hz). Maximum value: 100000 (100 kHz). The default value is 0.
Comment	Comment	An optional comment can be associated with this object. Double-click in the Comment column and type a comment.

Timing Diagram

This diagram displays the timing for the *FREQGEN* function block:

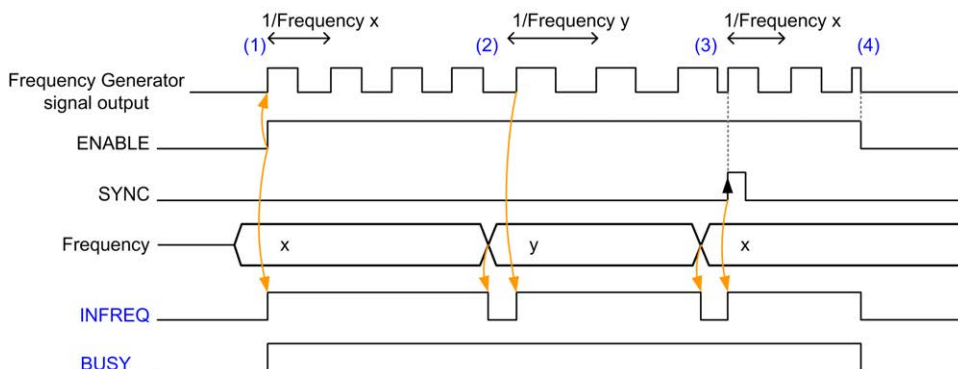

(1) The *ENABLE* input is set to 1. The frequency generator signal is generated at the dedicated output. The *INFREQ* output is set to 1. The *BUSY* output is set to 1.

(2) The frequency value is changed. The *INFREQ* output is set to 0 until the new frequency is being generated at the dedicated output. The *BUSY* output remains set to 1.

(3) The *SYNC* input is set to 1. The current frequency generator cycle stops and a new cycle starts. The *INFREQ* output is set to 1. The *BUSY* output remains set to 1.

(4) The *ENABLE* input is set to 0. Frequency generation stops. The *INFREQ* output is set to 0. The *BUSY* output is set to 0.

When the application is stopped, frequency generation stops without waiting for the end of the pulse generation cycle. The *Error* output remains at *FALSE*.

If an error is detected, it is automatically acknowledged when leaving the error condition.

Advanced Software Functions

What's in This Part

PID Function.....	149
-------------------	-----

Overview

This part describes the PID function.

PID Function

What's in This Chapter

PID Operating Modes	149
PID Auto-Tuning Configuration	150
PID Standard Configuration	153
PID Assistant	162
PID Programming.....	170

PID Operating Modes

PID Operating Modes

Introduction

The EcoStruxure Machine Expert - Basic *PID* controller offers 4 distinct operating modes, configurable in the **General** tab, page 163 of the **PID Assistant** in EcoStruxure Machine Expert - Basic.

The *PID* operating modes are:

- PID mode
- AT + PID mode
- AT mode
- Word address

PID Mode

The simple *PID* controller mode is active by default when the *PID* controller starts up. The gain values K_p , T_i , and T_d to be specified in the **PID** tab, page 165 must be known in advance to successfully control the process. You can choose the corrector type of the controller (PID or PI) in the **PID** tab of the **PID Assistant** screen, page 162. If the PI corrector type is selected, the derivative time **Td** field is disabled.

Using *PID* mode, the Auto-Tuning function is disabled and the **AT** tab, page 167 of the **Assistant Configuration** screen is therefore unavailable.

AT + PID Mode

In this mode, the Auto-Tuning function is active when the *PID* controller starts up. The Auto-Tuning function then calculates the gain values K_p , T_i , and T_d , page 165 and the type of PID action, page 168. At the end of the Auto-Tuning sequence, the controller switches to *PID* mode for the adjusted setpoint, using the parameters calculated by Auto-Tuning.

If the Auto-Tuning algorithm detects an error, page 172:

- No *PID* parameter is calculated.
- The Auto-Tuning output is set to the output that was applied to the process before starting Auto-Tuning.
- An error message appears in the **List of PID States** drop-down list.
- The *PID* control is cancelled.

While in *AT + PID* mode, the transition from Auto-Tuning to *PID* mode is automatic and seamless.

AT Mode

In this mode, the Auto-Tuning function is active when the *PID* controller starts up and automatically calculates both the gain values K_p , T_i , and T_d , page 165 and the type of *PID* action, page 168. After convergence of the Auto-Tuning process and successful completion with the determination of the K_p , T_i , and T_d parameters and the type of *PID* action, page 168 (or after detection of an error in the Auto-Tuning algorithm), the Auto-Tuning numerical output is set to 0 and the **Auto-Tuning Complete** message appears in the List of *PID* States, page 172 drop-down. The *PID* controller then stops and waits. The calculated K_p , T_i , and T_d *PID* coefficients are available in their respective memory words ($\%MWx$).

Word Address

This *PID* mode is selected by assigning the desired value to the word address associated with this selection:

- $\%MW_{xx} = 0$: The controller is disabled.
- $\%MW_{xx} = 1$: The controller operates in simple *PID* mode.
- $\%MW_{xx} = 2$: The controller operates in *AT+PID* mode.
- $\%MW_{xx} = 3$: The controller operates in *AT* mode only.
- $\%MW_{xx} = 4$: The controller operates in simple *PID* mode, with PI corrector type.

The *word address* mode enables you to manage the *PID* controller operating mode with the application, thus making it possible to adapt to your requirements.

PID Auto-Tuning Configuration

PID Auto-Tuning Configuration

Introduction

This section guides you through all the steps necessary to configure the EcoStruxure Machine Expert - Basic *PID* controller using Auto-tuning (AT).

This section contains the following steps:

Step	Topic
1	Configuring analog channel, page 150
2	Pre-requisites for <i>PID</i> configuration, page 151
3	Configuring the <i>PID</i> , page 151
4	Control set-up, page 152

Step 1: Configuring the Analog Channel

A *PID* controller uses an analog feedback signal (known as the process value) to calculate the algorithm used to control the process. The logic controller has an embedded analog input that can be used to acquire this process value. Refer to the M221 Logic Controller - Programming Guide for more details about analog input configuration.

If an analog output is being used to drive the system to be controlled, make sure that this analog output is correctly configured. Refer to the analog output expansion module of your logic controller.

Step 2: Pre-requisites for PID Configuration

Before configuring the *PID* controller, ensure that the following phases have been performed:

Phase	Description
1	PID is enabled in the program, page 170.
2	Scan Mode is set to periodic, page 171.

Step 3: Configuring the PID

Use a solid state output in conjunction with the PID function. Using a relay output may result in quickly exceeding its life cycle limits resulting in an inoperative relay with contacts either frozen open or soldered closed.

▲ WARNING
UNINTENDED EQUIPMENT OPERATION OR INOPERABLE EQUIPMENT
<ul style="list-style-type: none"> • Do not use relay outputs in conjunction with the PID function. • Only use solid state outputs if a digital output is required to drive the system to be controlled.
Failure to follow these instructions can result in death, serious injury, or equipment damage.

To implement a *PID* controller with Auto-Tuning, perform the following steps:

Step	Action
1	In the General tab, page 163 of the PID Assistant screen (in offline mode), select AT+PID (or AT) or select Word Address setting the associated word to 2 or 3, from the Operating Modes , page 149.
2	Activate the PID States checkbox and enter the address of the memory word in the field.
3	In the Input tab, page 164, enter the address of the analog input used as a measurement.
4	If Conversion or Alarms are required, refer to Input tab, page 164 of PID Assistant screen.
5	In the PID tab, page 165, enter the value of the setpoint. In general, this value is a memory address or an analog input.
6	Corrector type in the PID tab must be set to PID or PI .
7	Set the Parameters in the PID tab: Kp (x0,01) , Ti (x0,1s) , and Td (x0,1s) . When AT+PID or AT are the Operating modes , page 149, the parameters should be memory words addresses (%MWxx) so the Auto-Tuning algorithm fills in the computed value of the parameters.
8	Enter the PID Sampling period (T_s , page 155) in the PID tab. The Sampling period is a key parameter and must be carefully determined.
9	In the AT tab, the AT Mode must be set to Authorize by default. Enter the Min. and Max. values if the Measurement Range is activated (Authorize checkbox). Select the Dynamic AT corrector from the list that contains Fast , Medium , Slow , or Word address corrector type. For further details, refer to the AT tab in PID Assistant , page 162.
10	In the AT tab, enter the AT Trigger memory bit to store the value of the step change during Auto-Tuning. For further details, refer to the AT tab in PID Assistant , page 162.
11	<p>In the Output tab, page 168, set the Action by selecting in the list.</p> <p>If Bit Address is selected, enter the memory bit address in the Bit field.</p> <p>If necessary, you can configure Limits.</p> <p>If Manual mode is enabled, choose a memory word or an analog output. If Bit address is selected, enter a Bit. For more details about manual mode operation, refer to the Output tab, page 168.</p> <p>In the Analog output field, set Output PWM, page 168 to Authorize.</p> <p>Set an analog output or a memory word as the address of the word.</p> <p>Enter the value in the Period (x0.1 s) field and the memory bit or digital output.</p>
12	Click OK to confirm the <i>PID</i> controller configuration.

Step 4: Control Setup

Use a solid state output in conjunction with the PID function. Using a relay output may result in quickly exceeding its life cycle limits resulting in an inoperative relay with contacts either frozen open or soldered closed.

▲ WARNING

UNINTENDED EQUIPMENT OPERATION OR INOPERABLE EQUIPMENT

- Do not use relay outputs in conjunction with the PID function.
- Only use solid state outputs if a digital output is required to drive the system to be controlled.

Failure to follow these instructions can result in death, serious injury, or equipment damage.

To start operation in *AT+PID* operating mode, page 149 perform the following steps:

Step	Action
1	Connect the PC to the controller and transfer the application.
2	Switch the controller to RUNNING state.

NOTE: Before switching the controller to RUNNING state, verify that the operating conditions of the machine allow the RUNNING state for the rest of the application.

Step	Action
1	Create an animation table containing the objects defined during configuration. Refer to the <i>Ecostruxure Machine Expert - Basic Operating Guide</i> for further details about animation table creation.
2	Verify the consistency of the process value and application's values. This test is important as successful operation of the <i>PID</i> controller depends on the accuracy of the measurement. If you have any doubt about the accuracy of the measurement, set the logic controller to the STOP state and verify the wiring of analog channels. If the actuator is not controlled: <ul style="list-style-type: none"> • For analog output verify the output voltage or current from analog channel. • For PWM output, verify that the: <ul style="list-style-type: none"> ◦ LED of the dedicated output is lit ◦ Wiring of the supplies and 0V circuit ◦ Actuator power supply is being applied
3	In the animation table, verify that: <ul style="list-style-type: none"> • Output mode is set to automatic. • All parameters your application requires are set to the appropriate values.
4	Set the logic controller scan period so that the Sampling period (T_s) value of the <i>PID</i> controller is an exact multiple of the scan period. For further details on how to determine the Sampling period, refer to <i>Tuning PID</i> , page 155.
5	When the Auto-Tuning sequence is complete, the parameters Kp , Ti , and Td are written in to the RAM memory of the logic controller. The values are saved for as long as the application is valid (power-down less than 30 days) and no cold-start is performed.

The Auto-Tuning process is repeated each time a rising edge is detected on the **AT trigger** memory bit.

NOTE: When the PID autotuning is in the process of calibration to find the new parameters for **Kp**, **Ti**, **Td** and the manual output control is activated, launch PID autotuning again after finishing manual output control so that the parameters are updated.

PID Standard Configuration

PID Word Address Configuration

Introduction

This section guides you through all the steps required to configure the EcoStruxure Machine Expert - Basic *PID* controller using the **Word address** operating mode, page 149. This mode provides greater flexibility of use than the other *PID* modes.

This section contains the following steps:

Step	Topic
1	Prerequisites for PID configuration, page 153
2	Configuring the PID, page 153
3	Control set-up, page 154

Step 1: Prerequisites for PID Configuration

Before configuring the *PID*, ensure that the following phases have been performed:

Phase	Description
1	An analog input is configured as well as an analog output if required. Refer to the M221 Logic Controller - Programming Guide.
2	PID is enabled in the program, page 170.
3	Scan mode is set to periodic, page 171.

Step 2: Configuring the PID

Use a solid state output in conjunction with the PID function. Using a relay output may result in quickly exceeding its life cycle limits resulting in an inoperative relay with contacts either frozen open or soldered closed.

▲ WARNING
UNINTENDED EQUIPMENT OPERATION OR INOPERABLE EQUIPMENT
<ul style="list-style-type: none"> • Do not use relay outputs in conjunction with the PID function. • Only use solid state outputs if a digital output is required to drive the system to be controlled.
Failure to follow these instructions can result in death, serious injury, or equipment damage.

The following steps explain how to implement a *PID* controller in **Word address** mode. For more details on how to configure the *PID*, refer to the **PID Assistant section**.

For the dynamic modification of the *PID* parameters (in offline and in online mode), enter the memory addresses in the associated fields, thus avoiding the need to switch to offline mode to make on-the-fly changes to values.

Step	Action
1	In the General tab of the PID Assistant screen (in offline mode), in the Operating Modes ; drop-down list select Word address . Check the box associated to PID States and enter the address of the memory word in the field.
2	In the Input tab, page 164, enter the address of the analog input used as a measurement. If Conversion or Alarms are required, refer to Input tab, page 164 of PID Assistant, page 162.
3	In the PID tab, enter the value of the Setpoint . In general, this value is a memory address or an analog input. The Parameters (Kp, Ti, and Td) should be memory words addresses (%MWxx) . Enter the PID Sampling period (Ts, page 166) in the PID tab, page 165. This parameter can also be a memory word (the value can then be set using the animation table). In Word Address operating mode, the Corrector type is set to Auto and greyed out (it cannot be modified manually).
4	In the AT tab, the AT mode should be checked to Authorize . Enter the Dynamic corrector and the AT Trigger . For further details, refer to AT tab, page 167 in PID Assistant screen.
5	In the Output tab, Action should be set to Bit Address . Enter a memory bit address . Limits can be configured if necessary from the Output tab, page 168. In Analog output field set the address of the word: an analog output or a memory word. If required, set the Output PWM , refer to Output tab, page 168 in PID Assistant, page 162.
6	Click OK to confirm the PID controller configuration.

Step 3: Verifying the Setup

Step	Action
1	Connect the PC to the logic controller and transfer the application.
2	Switch the logic controller to RUNNING state.

NOTE: Before switching the logic controller to RUNNING state, verify that the operating conditions of the machine allow RUNNING state for the rest of the application. The procedure remains the same as the one used in **AT** and **AT +PID** operating modes. The word address configuration allows you to modify the PID operating modes by software. In the case of the PID mode, the procedure is significantly simplified, assuming the parameters (Kp, Ti, Td, and Ts) are known and there is no need to perform Auto-Tuning.

This table gives the generic procedure to set up the *PID* controller:

Step	Action
1	Create an animation table containing the objects defined during configuration. Refer to the <i>EcoStruxure Machine Expert - Basic Operating Guide</i> for details.
2	Verify the consistency of the process value and other values defined in the animation table. If you have any doubt about the accuracy of the measurement, set the logic controller to STOP and verify the wiring of analog channels. If you see that the actuator is not being controlled: <ul style="list-style-type: none"> • For analog output, verify the output voltage or current from analog channel. • For PWM output, verify that the: <ul style="list-style-type: none"> ◦ LED of dedicated output is lit ◦ Wiring of the supplies and 0 V circuit is correct ◦ Actuator power supply is being applied
3	Set the logic controller scan period so that the Sampling period (Ts) of the <i>PID</i> controller is an exact multiple of the scan period. For further details on Sampling period, refer to <i>Determining Sampling Period</i> , page 160
4	If you plan to use the Auto-Tuning, page 155 function, you may need to run Manual Mode, page 158 to know the Dynamic corrector and the AT Trigger defined in the AT tab, page 167 of the PID Assistant .
5	Power up the loop controller using the animation table: <ul style="list-style-type: none"> • Set the operating mode, page 149. • Enable the PID controller, page 171. • Set the values defined during configuration, page 153 to appropriate values depending on the selected operating mode.

PID Tuning with Auto-Tuning (AT)

Introduction

The Auto-Tuning mode allows automatic tuning of the Kp, Ti, Td, and action parameters to achieve refined convergence of the *PID* function. The Auto-Tuning function provided by EcoStruxure Machine Expert - Basic is particularly suited for automatic tuning of thermal processes.

This section contains the following topics:

- Auto-Tuning requirements
- Description of Auto-Tuning process
- Storage of Calculated Coefficients
- Adjusting *PID* parameters
- Launching the Auto-Tuning
- Limitations on using the Auto-Tuning and the *PID* control

Auto-Tuning Requirements

When using the Auto-Tuning function, make sure that the control process and the logic controller meet the following requirements:

- Process requirements:
 - The process must be a stable open-loop system.
 - The process must be mostly linear over the entire operating range.
 - The process response to a change in level of the analog output follows a transient asymptotic pattern.
 - The process is in a steady state with a null input at the start of the Auto-Tuning sequence.
 - The process must be free of disturbances throughout the entire process. Otherwise, either calculated parameters will be incorrect or the Auto-Tuning process will not operate correctly.
- Configuration requirements:
 - Configure the logic controller to periodic scan mode to ensure a correct run of the Auto-Tuning function.
 - Only use the Auto-Tuning function when no other *PID* controllers are running.
 - Configure the K_p , T_i , and T_d coefficients as memory word addresses (%*MWxx*).
 - Set the Action type in the **Output** tab to a memory bit address (%*Mxx*).

Description of Auto-Tuning Process

The following illustration describes the auto-tuning in the controller and in the application:

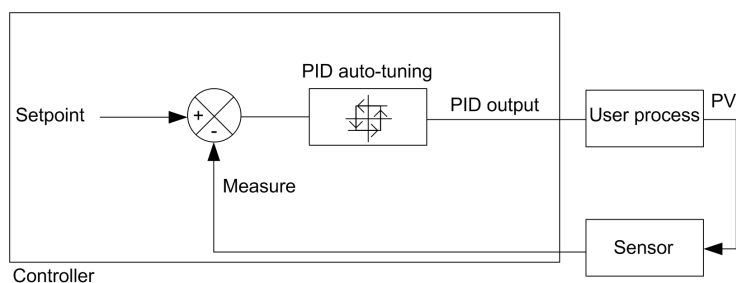

Description of Auto-Tuning Calibration Process

The Auto-Tuning calibration process is divided into four consecutive phases. All phases of the process must be fulfilled in order to bring the Auto-Tuning to a successful conclusion. The following process response curves and table describe the four phases of the EcoStruxure Machine Expert - Basic PID Auto-Tuning function:

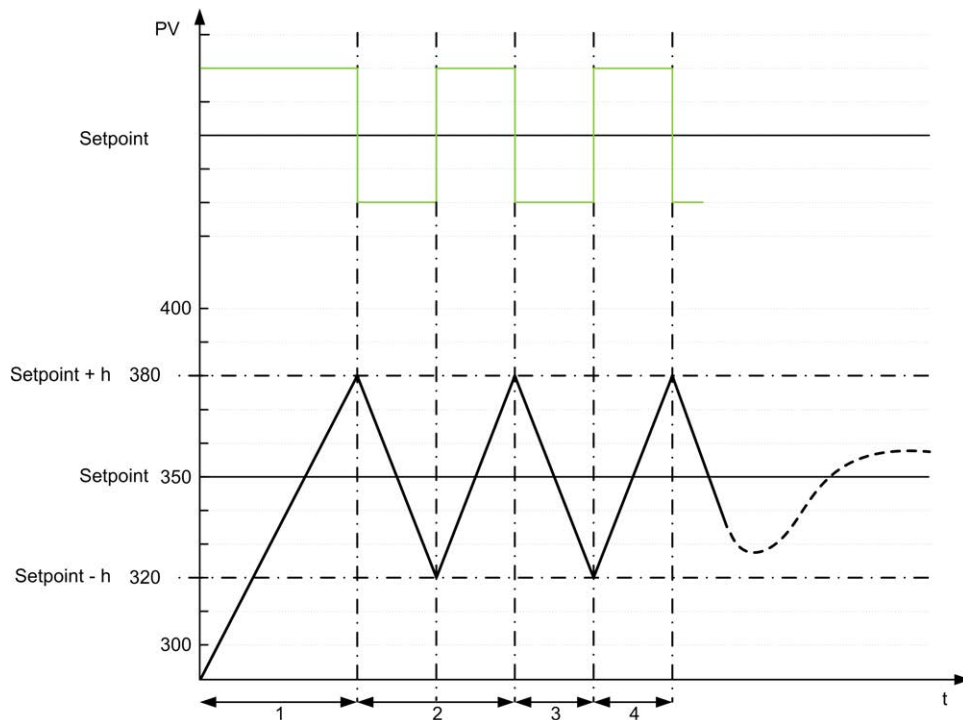

PV Process value

█ PID output

h = 1% (**Max** value - **Min** value) of **Measurement Range** field in the **AT** tab

---- PID active

1...4 Auto-Tuning phases (see table below)

The following table describes the Auto-Tuning phases:

Auto-Tuning Phase	Description
1	The PID output is forced to the Max value of Limits field in Output tab, page 169 until the process value reaches Setpoint + h.
2	There are two steps in Auto-Tuning phase 2: 1. The PID output is forced to the Min value of the Limits field in the Output tab, page 169 until the process value reaches Setpoint - h. 2. The PID output is forced to the Max value of the Limits field in the Output tab, page 169 until the process value reaches Setpoint + h.
3	The PID output is forced to the Min value of the Limits field in the Output tab, page 169 until the process value reaches Setpoint - h.
4	There are two steps in Auto-Tuning phase 4: 1. The PID output is forced to the Max value of the Limits field in the Output tab, page 169 until the process value reaches Setpoint + h. 2. The PID output is forced to the Min value of the Limits field in the Output tab, page 169, the PID parameters are calculated and the PID becomes active.

(1) The output last applied to the process before start of the Auto-Tuning is used as both the starting point and the relaxation point for the Auto-Tuning process.

NOTE: The K_p , T_i and T_d parameters cannot be calculated if the manual output control is activated during the Auto-Tuning calibration process. Launch the Auto-Tuning calibration process again once the output manual control is finished.

Storage of Calculated Coefficients

After the Auto-Tuning sequence is complete, the memory words assigned to the K_p , T_i , and T_d coefficients and the action type are set using the calculated values. These values are written in to the RAM memory and saved in the logic controller as long as the application is valid and no cold start is performed (%S0).

If the system is not influenced by outside disturbances, the calculated values may be written in to the settings of the *PID* controller (refer to the **PID** tab of the **PID Assistant**, page 168). In this way, the *PID* controller operating mode can be set to *PID* mode.

Adjusting PID Parameters

The Auto-Tuning method may provide a very dynamic command, leading to unwanted overshoots during step change of setpoints. To refine the process regulation provided by the *PID* parameters (K_p , T_i , T_d) obtained from Auto-Tuning, you also have the ability to adjust these parameter values manually, directly from the **PID** tab of the **PID Assistant** screen or through the corresponding memory words (%MW). For more details on manual parameters adjustments, refer to the appendices, page 175.

Launching the Auto-Tuning

In the **AT** tab, the **AT Trigger** enables the repetition of Auto-Tuning sequence. The auto-tuning process is launched at each rising edge of the signal linked to **AT Trigger**.

To configure the auto-tuning, refer to **AT Tab**, page 167.

Limitations on Using Auto-Tuning

Thermal processes can often be assimilated to the first order with pure delay model. There are two key parameters that describe this type of model:

- the time constant, τ
- the delay time, θ

Auto-Tuning is best suited for processes in which the time constant (τ) and delay time (θ) meet the following criteria:

- $10 \text{ s} < (\tau + \theta) < 2700 \text{ s}$ (i.e.: 45 min)
- $2 < \tau / \theta < 20$

Manual Mode

Introduction

The manual mode is accessible through the **PID Assistant** screen (**Output** tab, page 168). This mode allows you to bypass orders from the *PID*. There are 2 main objectives using Manual mode:

- Initialize the set-up
- Determine the sampling period.

Description

Manual mode lets you specify the **Output** value, page 168. This operation can be particularly well suited for testing the system response.

Setting the **Bit address** from the **Output** tab, page 168 to 1 activates the manual mode. If **Enable** is set, then manual mode is the only accessible mode.

Application

When manual mode is active the output is assigned a fixed value that you set. This output value is from 0 to 10,000 (0 to 100% for PWM output).

You can also use manual mode to make trials to determine the minimum/maximum output limitation.

Manual mode is also required to use the process curve response method, page 160 that helps to find the correct sampling time (*T_s*).

Start the Manual Mode

Before starting manual mode, you should make sure that the logic controller RUN/STOP switch is in the RUN position.

To start manual mode using an animation table:

Step	Description
1	Enable manual mode by setting the dedicated memory bit to 1. For more details refer to the Output tab, page 168.
2	If using PWM, set the PWM Period to the desired value.
3	Set the memory word associated with the Operating mode in the General tab, page 163 of the PID Assistant to 1 (<i>PID</i> mode). For more details on operating modes using word address refer to the operating mode description, page 149.
4	Set the memory word associated with the manual output in the Output tab, page 168 to the desired value. This manual setpoint value can be selected several times on condition that the system is left in its initial state.
5	Enable the loop controller, page 153.

Stop the Manual Mode

To stop manual mode using an animation table:

Step	Description
1	Disable the loop controller, page 153.
2	Inhibit the manual mode by setting the dedicated memory bit to 0. For more details refer to the Output tab, page 168.
3	Set the memory word associated with the Operating mode in the General tab, page 163 for the <i>PID</i> controller to 0. For more details on operating modes using word address, refer to the operating mode description, page 149.
4	Set the memory word associated to the manual output in the Output tab, page 168 to 0.

Determining the Sampling Period (Ts)

Introduction

The Sampling Period (Ts) is the key parameter for *PID* regulation. The Sampling Period (Ts) should be carefully set in the **PID** tab, page 165 of the **PID Assistant** screen. This parameter is highly correlated with the time constant (τ) of the process to control.

This section describes the use of online mode and two methods to determine the sampling period (Ts) are described in this section:

- Process response curve method,
- Trial-and-error method.

Process Response Curve Method

This method is an open loop process that aims to determine the time constant of the process to be controlled. First, it is necessary to ensure that the process can be described by a first order with time delay model. The principle is quite simple: apply a step change at the input of the process while recording the process output curve. Then use a graphical method to determine the time delay of the process.

To determine the sampling period (Ts) using the process response curve method:

Step	Action
1	It is assumed that you have already configured the various settings in the General , Input , PID , AT and Output tabs of the <i>PID</i> .
2	Select the Output tab, page 168 from the PID Assistant screen.
3	Select Enable or Bit address from the Manual Mode drop-down list to authorize manual output.
4	Set the Output field to a high level (in the [5,000...10,000] range).
5	Download your application to the logic controller. For further details on how to download an application refer to the <i>EcoStruxure Machine Expert - Basic Operating Guide</i> .
6	Run the <i>PID</i> and check the response curve rise.
7	When the response curve has reached a steady state, stop the <i>PID</i> measurement.
8	Use the following graphical method to determine the time constant (τ) of the control process: <ol style="list-style-type: none"> 1. Calculate the process value output at 63% rise ($S_{[63\%]}$) by using the following formula: $S_{[63\%]} = S_{[initial]} + (S_{[final]} - S_{[initial]}) \times 63\%$ 2. Calculate graphically the time abscissa ($t_{[63\%]}$) that corresponds to $S(63\%)$. 3. Calculate graphically the initial time ($t_{[initial]}$) that corresponds the start of the process response rise. 4. Compute the time constant (τ) of the control process by using the following relationship: $\tau = t_{[63\%]} - t_{[initial]}$
9	Calculate the Sampling Period (Ts) ⁽¹⁾ based on the value of (τ) that you determined in the previous step, using the following rule: $Ts = \tau/75$
10	Set the scan Period of the Periodic Scan mode so that the Sampling Period (Ts) is an exact multiple of the scan period: $Scan\ Period = Ts / n$, where n is a positive integer ⁽²⁾
<p>(1) The base unit for the Sampling Period is 10 ms. Therefore, you should round up/down the value of Ts to the nearest 10 ms.</p> <p>(2) You must choose "n" so that the resulting Scan Period is a positive integer in the range [1...150] ms.</p>	

Trial-and-Error Method

The trial-and-error method involves providing successive guesses of the sampling period to the Auto-Tuning function until the algorithm converges successfully towards satisfactory values of Kp, Ti, and Td.

NOTE: Unlike the process response curve method, the trial-and-error method is not based on any approximation law of the process response. However, it has the advantage of converging towards a value of the sampling period that is in the same order of magnitude as the actual value.

To perform a trial-and-error estimation of the Auto-Tuning:

Step	Action
1	Select the AT tab from the <i>PID</i> configuration window.
2	Set the Output limitation of Auto-Tuning to 10,000 .
3	Download your application to the logic controller. For further details on how to download an application, refer to EcoStruxure Machine Expert - Basic operating guide (see EcoStruxure Machine Expert - Basic, Operating Guide).
4	Select the PID tab from the PID Assistant screen.
5	Provide the first or <i>n</i> th guess in the Sampling Period ⁽¹⁾ field.
6	Launch Auto-Tuning, page 150.
7	Wait until the Auto-Tuning process ends.
8	Two cases can occur: <ul style="list-style-type: none"> • Auto-Tuning completes successfully: Continue to Step 10. • Auto-Tuning unsuccessful: Refer to Auto-Tuning detected error codes, page 173. This means that the current guess for the Sampling Period (Ts) is not correct. Try a new Ts guess and repeat steps 3 through 8, as many times as required until the Auto-Tuning process eventually converges.
9	Follow these guidelines to provide a new Ts guess: <ul style="list-style-type: none"> • Auto-Tuning ends with the detected error code 800C hex. This means the Sampling Period (Ts) is too large. Decrease the value of Ts to provide a new guess. • Auto-Tuning ends with the detected error code 800A hex. This means the Sampling Period (Ts) is too small. Increase the value of Ts to provide a new guess.
10	Adjust the <i>PID</i> control parameters ⁽²⁾ (Kp, Ti, and Td) in the PID tab , page 165 of the PID Assistant screen, as needed.
<p>(1) If you do not have any first indication of the possible range for the sampling period, set this value to the minimum possible: 1 (1 unit of 10 ms).</p> <p>(2) If the PID regulation provided by this set of control parameters does not provide results that are totally satisfactory, you may still refine the trial-and-error evaluation of the sampling period until you obtain the correct set of Kp, Ti, and Td control parameters.</p>	

Online Mode

In online mode, when the logic controller is in the periodic task, the value displayed in the Ts field (in the **PID Assistant** screen, page 162) can be different from the parameter entered (%MW). The Ts value is a multiple of the periodic task, whereas the %MW value is the value read by the logic controller.

PID Assistant

Access the PID Assistant

Introduction

Use the **PID Assistant** window of EcoStruxure Machine Expert - Basic to enable you to configure the *PID* controller.

Configuration Assistant

In the *PID* properties table, click the **Configuration [...]** button. The **PID Assistant** screen will appear.

This graphic displays the **PID Assistant** screen:

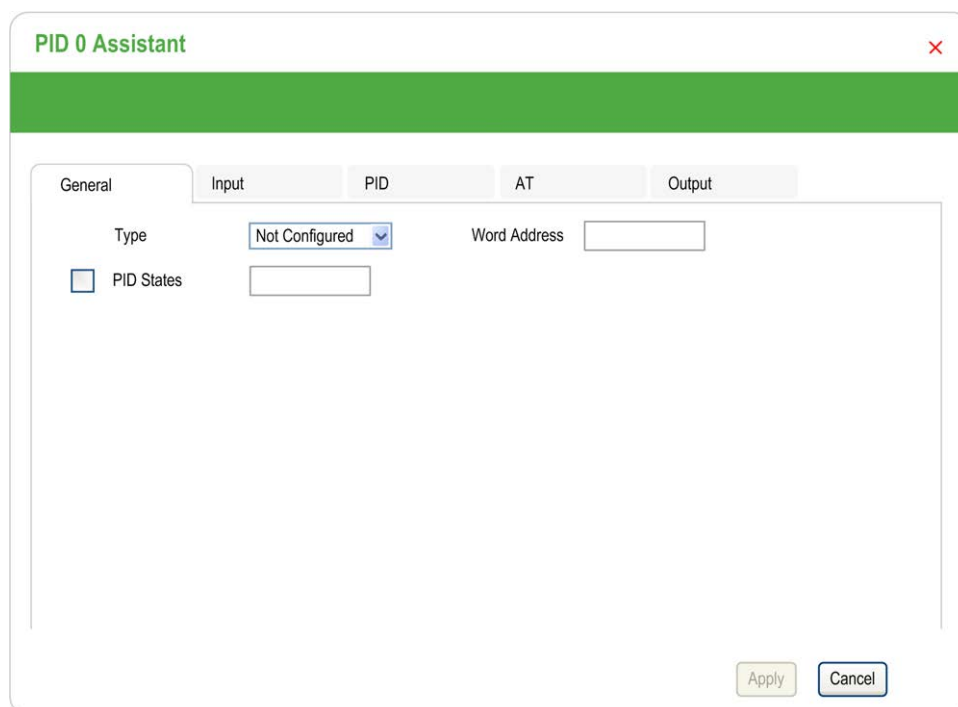

The **PID Assistant** screen displays several tabs, depending whether, you are in offline or online mode:

Tab	Access mode	Link
General	Offline	General tab, page 163
Input	Offline	Input tab, page 164
PID	Offline	PID tab, page 165
AT	Offline	AT tab, page 167
Output	Offline	Output tab, page 168

Once an operating mode is selected, tabs containing empty fields that require values are shown as display  and the border of the field is filled in red.

General Tab

Introduction

This section describes the **General** tab of the *PID*. **General** tab is displayed by default when you access the *PID* Assistant in offline mode.

Description

The table below describes the settings on the **General** tab.





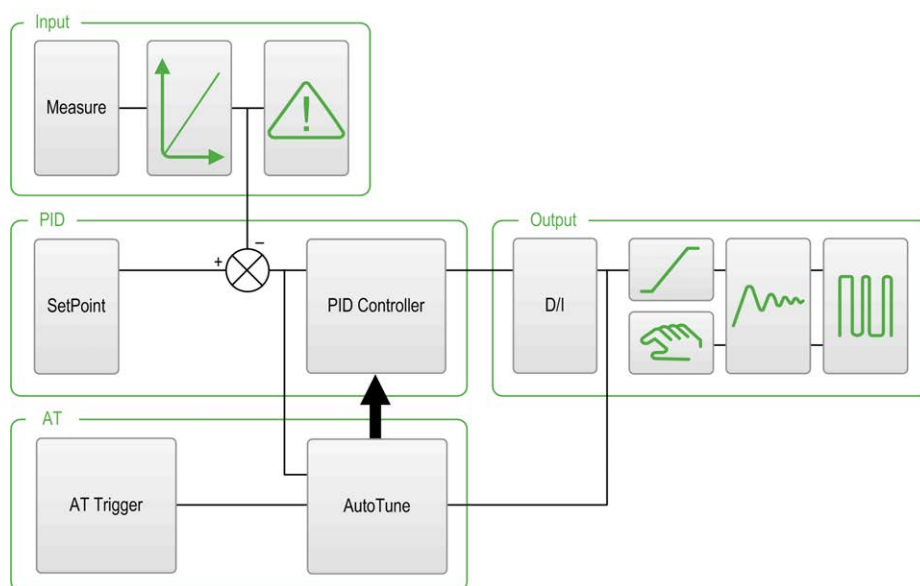





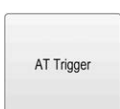

Parameter	Description
Operating Mode	Represents the <i>PID</i> mode to use: <ul style="list-style-type: none"> • Not configured • PID • AT + PID • AT • Word address For further details about operating modes, refer to PID Operating Mode, page 149.
Word address	You can provide a memory word in this text box (%MWxx) that is used to programmatically set the operating mode. The memory word can take possible values depending on the operating mode you want to set: <ul style="list-style-type: none"> • %MWx = 0 (PID disabled) • %MWx = 1 (to set PID only) • %MWx = 2 (to set AT + PID) • %MWx = 3 (to set AT only) • %MWx = 4 (to set PI only)
PID States	If you check the box to enable this option, you can provide a memory word in the associated field (%MWxx) that is used by the <i>PID</i> controller to store the current <i>PID</i> state while running the <i>PID</i> controller and/or the Auto-Tuning function. For more details, refer to PID States and Detected Error Codes, page 172.

Graphical Assistant



The graphical assistant helps you to visualize how the *PID* function is built. This is a dynamic graphic that is updated according to the configuration.

The icons shown below describe when it is accessible or what happens if you click on it:

Display	Description
	Click this button to display the SetPoint field of the PID tab, page 165.
	Click this button to display the PID tab, page 165.
	Click this button to display the Output tab, page 168.
	Click this button to display the Input tab, page 164.
	Click this button to display the AT tab, page 167.
	Click this button to display the AT tab, page 167.
	This button appears when the Authorize option is checked in the Conversion zone of the Input tab, page 164.
	This button appears when the Authorize option is checked in the Alarms zone of the Input tab, page 164.
	This button appears if Limits is not equal to Disable in the Limits zone of the Output tab, page 168.
	This button appears if Manual mode is not equal to Disable in the Manual mode zone of the Output tab, page 168.
	Click this button to display the Output tab, page 168.
	This button appears when the Authorize option is checked in the Output PWM zone of the Output tab, page 168.

Input Tab

Introduction

This section describes the **Input** tab of *PID*. The **input** tab is used to enter the *PID* input parameters.

This tab is only accessible in offline mode and when an operating mode is selected from the **General** tab.

Description

The table below describes the settings that you may define.

Parameter	Description	
Measure	Specify the variable that contains the process value to be controlled. The default scale is from 0 to 10000. You can enter either a memory word (%MWxx) or an analog input.	
Conversion	Authorize	Activate this box to convert the process value [0...10000] into a linear range Min. ... Max. . The conversion also applies to the setpoint value.
	Min. Max.	Specify the minimum and maximum values of the conversion scale. The process value is then automatically rescaled within the Min. ... Max. interval. Min. or Max. can be memory words (%MWxx), constant words (%KWxx), or a value from -32768 to +32767. NOTE: Note: The Min. must be less than the Max. .
Filter	Authorize	Activate this box to apply a filter to the measured input.
	(100 ms)	Specify the filter value from 0 to 10000 or a memory word address (%MWxx). The filter time base unit is 100 ms.
Alarms	Authorize	Activate this box to activate alarms in input variables. The alarm values should be determined relative to the process value obtained after the conversion phase. The alarm values must be from Min. to Max. when conversion is active. Otherwise, the alarm values will be from 0 to 10000.
	Low Output	Specify the low alarm value in the Low field. This value can be a memory word (%MWxx), a constant (%KWxx), or a direct value. Output must contain the address of the bit, which will be set to 1 when the lower limit is reached. Output can be either a memory bit (%Mxx) or an output.
	High Output	Specify the high alarm value in the High field. This value can be a memory word (%MWxx), a constant (%KWxx), or a direct value. Output must contain the address of the bit, which will be set to 1 when the upper limit is reached. Output can be either a memory bit (%Mxx), or an output.

PID Tab

Introduction

Use **PID** tab to enter the internal *PID* parameters.

This tab is only accessible in offline mode and if an operating mode has been selected from the **General** tab.

Description

This table describes the settings that you may define:

Parameter	Description	
Setpoint	<p>Specify the <i>PID</i> setpoint value. This value can be a memory word (<i>%MWxx</i>), a constant word (<i>%KWxx</i>), or a direct value.</p> <p>This value must therefore be between 0 and 10000 when conversion is inhibited. Otherwise it must be between the Min. value and the Max. value for the conversion.</p>	
Corrector type	<p>If the PID or AT + PID operating mode has been previously chosen in the <i>PID</i> properties table, you can select the desired corrector type (PID or PI) from the drop-down list. If other operating modes (AT or Word Address) have been chosen, the Corrector type is set to Auto and greyed out (it cannot be modified manually).</p> <p>If PI is selected from the drop-down list, the <i>Td</i> parameter is forced to 0 and this field is disabled.</p>	
Parameters ⁽¹⁾	Kp (x0,01s)	<p>Specify the <i>PID</i> proportional gain, multiplied by 100.</p> <p>This value can be a memory word (<i>%MWxx</i>), a constant word (<i>%KWxx</i>), or a direct value.</p> <p>The valid range for the <i>Kp</i> parameter is: $0 < Kp < 10000$.</p> <p>NOTE: If <i>Kp</i> is mistakenly set to 0 ($Kp \leq 0$ is invalid), the default value $Kp=100$ is automatically assigned by the <i>PID</i> function.</p>
	Ti (x0,1s)	<p>Specify the integral time for a timebase of 0.1 seconds.</p> <p>This value can be a memory word (<i>%MWxx</i>), a constant word (<i>%KWxx</i>), or a direct value.</p> <p>It must be from 0 to 36000.</p> <p>NOTE: To disable the integral action of the <i>PID</i>, set this coefficient to 0.</p>
	Td (x0,1s)	<p>Specify the derivative time for a timebase of 0.1 seconds.</p> <p>This value can be a memory word (<i>%MWxx</i>), a constant word (<i>%KWxx</i>), or a direct value.</p> <p>It must be from 0 to 10000.</p> <p>NOTE: To disable the derivative action of the <i>PID</i>, set this coefficient to 0.</p>
Sampling period	<p>Specify the <i>PID</i> sampling period here for a timebase of 10^{-2} seconds (10 ms).</p> <p>This value can be a memory word (<i>%MWxx</i>), a constant word (<i>%KWxx</i>), or a direct value.</p> <p>It must be from 1 (0.01 s) to 10000 (100 s).</p>	
<p>(1) When Auto-Tuning is enabled, you no longer need to set the <i>Kp</i>, <i>Ti</i>, and <i>Td</i> parameters as they are automatically and programmatically set by the Auto-Tuning algorithm. In this case, you must enter in these fields an internal word address only (<i>%MWxx</i>). Do not enter a constant word or a direct value when Auto-Tuning is enabled.</p>		

AT Tab

Introduction

The **AT** tab is related to the Auto-Tuning function. For more details, refer to PID tuning with Auto-Tuning, page 155.

This tab is only accessible in offline mode and if an operating mode has been selected from the **General** tab.

Description

PID Auto-Tuning is an open-loop process that acts directly on the control process without regulation or any limitation other than provided by the Process Value (PV) limit and the output setpoint. Therefore, both values must be carefully selected within the allowable range as specified by the process to prevent potential process overload.

When the PID is implemented with Auto-Tuning, the **Dynamic AT Corrector** parameter affects the proportional gain (Kp) value. The computation of the proportional gain in Auto-Tuning process depends on the selected dynamic corrector speed. You can select one of the following options:

- **Fast**
- **Medium**
- **Slow**
- **Word address**

See the descriptions of the options in the table below.

⚠ WARNING
<p>UNSTABLE PID OPERATION</p> <ul style="list-style-type: none"> • The Process Value (PV) limit and the output setpoint values must be set with complete understanding of their effect on the machine or process. • Do not exceed the allowable range for Process Value and Output Setpoint values. <p>Failure to follow these instructions can result in death, serious injury, or equipment damage.</p>

⚠ WARNING
<p>UNINTENDED EQUIPMENT OPERATION</p> <p>Do not use a relay output with the PID function.</p> <p>Failure to follow these instructions can result in death, serious injury, or equipment damage.</p>

This table describes the settings that you may define:

Field	Description	
AT Mode	Authorize	<p>Activate this box to enable Auto-Tuning operation.</p> <p>There are 2 ways to use this checkbox, depending on whether you set the operating mode manually or via a word address in the General tab of the <i>PID</i> function:</p> <ul style="list-style-type: none"> If you set the Operating mode to PID + AT or AT from the General tab, page 163, then the Authorize option is activated and not editable. If you set the operating mode via a word address $\%MWx$ ($\%MWx = 2$: PID + AT; $\%MWx = 3$: AT), then you have to activate the Authorize option manually to allow configuring of the Auto-Tuning parameters.
Measurement Range	Authorize	<p>Activate this box to enable the range measurement.</p> <p>NOTE: If the range measurement is deactivated the Min. value is set to 0 and the Max. value is set to 10000.</p>
	Min. Max	<p>Set the Min. and Max values based on the measurement range of 1% above or below the setpoint.</p> <p>The values can be immediate values from 1 to 10000 or a memory word $\%MWx$.</p> <p>NOTE: The Min. value must be less than the Max value.</p> <p>Example: If the process value must be around $35^{\circ}\text{C} \pm 3^{\circ}\text{C}$:</p> <ul style="list-style-type: none"> The setpoint is 350. $\pm 3^{\circ}\text{C}$ is h, page 157 and should be 30. Therefore $1\% \times (\text{Max.} - \text{Min.}) = 30$ Therefore $1\% \times 3000 = 30$ Therefore Max. = 3100 and Min. = 100
Dynamic AT corrector	Fast Medium Slow Word address	<p>This parameter affects the proportional gain (K_p) value computed by the AT process.</p> <ul style="list-style-type: none"> Fast provides a fast response time with more overshoot than medium. Medium provides medium response time with medium overshoot. Slow provides slower a response time with less overshoot than medium. Word address provides the response time configured in the specified word object ($\%MW$).
AT Trigger	AT Trigger	<p>This parameter allows you to launch the AT process each time a rising edge is detected on the dedicated bit (memory bit or digital input bit).</p>

Calculated K_p , T_i , T_d Coefficients

Once the Auto-Tuning process is complete, the calculated K_p , T_i , and T_d *PID* coefficients are stored in their respective memory words ($\%MWx$).

Output Tab

Introduction

This tab is used to enter the *PID* output parameters.

This tab is only accessible in offline mode and if an operating mode has been selected from the **General** tab.

Description

This table describes the settings that you may define:

Field	Description
Action	<p>Specify the type of <i>PID</i> action on the process here. Three options are available: Reverse, Direct, and Bit Address. If an increase in the output causes an increase in the process value measurement, define inverted action (Reverse); on the other hand, if this causes a process value reduction, make the <i>PID</i> direct (Direct).</p> <p>If you select Bit Address⁽¹⁾, you can modify the action type by modifying the associated bit, which is either a memory bit (%Mxx) or an input address (%I.x.y).</p> <p>The memory bit is set to 1 if the action is Direct and the memory bit is set to 0 if the action is Reverse.</p>
Limits	<p>Specify whether to place limits on the <i>PID</i> output. 3 options are available: Enable, Disable, and Bit Address.</p> <p>Select Enable to set the Bit to 1 or select Disable to set the Bit to 0.</p> <p>Select Bit Address for limit management of the bit by modifying the associated bit, which is either a memory bit (%Mxx) or an input address (%I.x.y).</p> <p>Set the high and low limits for the <i>PID</i> output.</p> <p>Min. or Max. can be memory word (%MWxx), constant word (%KWxx), or a value from 1 to 10000 (0.01% to 100% of the PWM period).</p> <p>NOTE: The Min. value must be less than the Max. value.</p>
Manual mode	<p>Specify whether to change the <i>PID</i> to manual mode. 3 options are available: Enable, Disable, and Bit Address.</p> <p>If you select Bit Address, you can switch to manual mode (bit to 1) or automatic mode (bit to 0) using the program, by modifying the associated bit which is either a memory bit (%Mxx) or an input.</p> <p>The Output of manual mode must contain the value that you wish to assign to the analog output when the <i>PID</i> is in manual mode, page 158. This Output can be either a word (%MWxx) or a direct value in the [0...10,000] format.</p>
Analog Output	<p>Specify the <i>PID</i> output to use when in auto-tuning mode.</p> <p>This Analog Output⁽²⁾ can be a memory word address or an analog output address. When using the PWM function of <i>PID</i>, only memory word addresses are allowed.</p>
Output PWM	<p>Check this box to use the PWM function of <i>PID</i>.</p> <p>Specify the modulation period in the Period (x0.1 s) text box. This period must be from 1 to 500 and can be a memory word (%MWxx) or a constant word (%KWxx). PWM precision depends on both the PWM period and the scan period. The precision is improved when the PWM ratio (<i>PWM.R</i>) has the greatest number of values. For instance, with scan period = 20 ms and PWM period = 200 ms, <i>PWM.R</i> can take values 0%, 10%, 20%, 30%, 40%, 50%, 60%, 70%, 80%, 90%, 100%. With scan period = 50 ms and PWM period = 200 ms, <i>PWM.R</i> can take values 0%, 25%, 50%, 75%, and 100% of the period <i>PWM.P</i>.</p> <p><u>Example</u> : case of <i>PWM.R</i> = 75%</p> <p>Specify the PWM output bit as the value in Output. This can be either a memory bit (%Mxx) or an output address. For further details about PWM function, refer to the chapter Pulse Width Modulation (%PWM), page 47.</p>
<p>(1) When Auto-Tuning is enabled, the Auto-Tuning algorithm automatically determines the correct type of action direct or reverse for the control process. You must then enter in the associated Bit Address textbox a memory bit (%Mxx) only.</p> <p>(2) Enter a memory address (%MWxx) or an analog output address (%QWx.y).</p>	

PID Programming

Using PID Function

This section provides descriptions and programming guidelines for using **PID** function.

Description

Introduction

A proportional–integral–derivative (*PID*) is a generic control loop feedback mechanism (controller) widely used in industrial control systems. The *PID* controller uses an algorithm that involves 3 separate constant parameters: the proportional, the integral, and derivative values, denoted by P, I, and D respectively.

Key Features

The key features of the EcoStruxure Machine Expert - Basic PID function are as follows:

- Analog input
- Linear conversion of the configurable measurement
- High or low configurable input alarm
- Analog or PWM output
- Cutoff for the configurable output
- Configurable direct or inverse action
- Auto-tuning function

Illustration

This is the *PID* function in the Ladder editor of EcoStruxure Machine Expert - Basic:

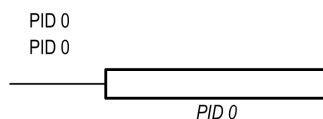

NOTE: There must be a space between PID and the PID number (for example, PID<space>0).

Parameters

Unlike the *Timer* or the *Counter* function blocks, there is no *PID* function block in EcoStruxure Machine Expert - Basic. The instruction `[PID x]` only enables the *PID* control loop function, where x is the PID number.

To configure the *PID* function, go to the **Programming** window, click **Tools > PID**, and then edit the PID properties (refer to the table below for the configuration parameters).

The *PID* function has the following parameters:

Parameter	Description	Value
Used	Checked if the I/O is used somewhere in the project	True/False False (Default)
PID	Name of the current <i>PID</i> object	A program can contain only a limited number of <i>PID</i> functions. For the maximum number of <i>PID</i> objects, refer to the table Maximum Number of Objects (see Modicon M221, Logic Controller, Programming Guide).
Symbol	Symbol of the current <i>PID</i> object	The symbol associated with this <i>PID</i> object. For details, refer to Defining and Using Symbols (see EcoStruxure Machine Expert - Basic, Operating Guide).
[...]	A button to launch the assistant	Click to display the PID Assistant screen. For further details, refer to PID Assistant, page 162.
Comment	Comment	A comment can be associated with this object.

Programming and Configuring

Introduction

This section describes how to program and configure the EcoStruxure Machine Expert - Basic *PID* controller.

Enabling the PID Controller

The following example enables the *PID 0* controller loop if the bit *%M0* is set to 1:

Rung	Instruction
0	LD %M0 [PID 0]

NOTE: Refer to the reversibility procedure (see EcoStruxure Machine Expert - Basic, Generic Functions Library Guide) to obtain the equivalent Ladder Diagram.

PID Analog Measurement

The *PID* function completes a *PID* correction using an analog measurement and setpoint and produces either an analog command in the same format or a PWM on a digital output.

To use *PID* at full scale (the highest resolution), configure the analog input dedicated to the *PID* controller measurement in [0...10,000] format. However, if you use the default configuration [0...4095], the *PID* controller will still function correctly.

Configuring the Scan Period

When using EcoStruxure Machine Expert - Basic *PID* controllers, you must configure the scan mode of the logic controller to **Periodic** scan mode (**Program** tab, **Tasks > Master Task**). In periodic scan mode, each scan of the logic controller starts at a regular time interval so the sampling rate is constant

throughout the measurement period. For further details on configuring the scan mode, refer to the *EcoStruxure Machine Expert - Basic Operating Guide*.

In periodic scan mode, the system bit %S19 is set to 1 by the system if the logic controller scan time is greater than the period defined by the user program.

PID States and Detected Error Codes

Introduction

The EcoStruxure Machine Expert - Basic *PID* controller has the ability to write the present state of both the *PID* controller and the Auto-Tuning process to a user-defined memory word. For further information on how to enable and configure the *PID* States memory word, refer to the **General** tab, page 163 of the *PID Assistant*, page 162.

The *PID* States memory word can record the following types of *PID* information:

- Present state of the *PID* controller
- Present state of the Auto-Tuning process
- *PID* detected error codes
- Auto-Tuning detected error codes

NOTE: The States memory word is read-only.

States Memory Word

States	Description
0000 hex	<i>PID</i> control is not active
2000 hex	<i>PID</i> control is in progress
4000 hex	<i>PID</i> setpoint has been reached

Auto-Tuning State Memory Word

Auto-Tuning State	Description
0100 hex	Auto-Tuning phase 1, page 157 in progress
0200 hex	Auto-Tuning phase 2, page 157 in progress
0400 hex	Auto-Tuning phase 3, page 157 in progress
0800 hex	Auto-Tuning phase 4, page 157 in progress
1000 hex	Auto-Tuning phase complete

PID Detected Error Codes

This table describes the potential detected errors that may be encountered during *PID* control:

Detected Error Code	Description
8001 hex	Operating mode value out of range
8002 hex	Linear conversion min and max equal
8003 hex	Upper limit for discrete output lower than lower limit
8004 hex	Setpoint limit out of linear conversion range
8005 hex	Setpoint limit less than 0 or greater than 10000
8006 hex	Setpoint out of linear conversion range
8007 hex	Setpoint less than 0 or greater than 10000
8008 hex	Control action different from action determined at Auto-Tuning start

Auto-Tuning Detected Error Codes

This table records the Auto-Tuning detected error messages and describes possible causes as well as troubleshooting actions:

Detected Error Code	Description
8009 hex	The Process Value (PV) limit has been reached. As Auto-Tuning is an open-loop process, the Process Value (PV) limit works as maximum allowed value.
800A hex	Either the sampling period is too small or the output setpoint is too low. Increase either the sampling period or the Auto-Tuning output setpoint value.
800B hex	Kp is zero.
800C hex	The time constant is negative so the sampling period may be too large. For more details, refer to <i>Limitations on Using the Auto-Tuning</i> , page 176.
800D hex	Delay is negative.
800E hex	<p>Detected error when calculating Kp. The Auto-Tuning algorithm is unstable (no convergence). This may be due to:</p> <ul style="list-style-type: none"> Disturbances on the process during Auto-Tuning has caused a distortion of the process static gain evaluation. The process value transient response is not large enough for Auto-Tuning to determine the static gain. A combination of the above. <p>Check the <i>PID</i> and Auto-Tuning parameters and make adjustments to improve convergence. Check also if there is no disturbance that could affect the process value. Try modifying:</p> <ul style="list-style-type: none"> the output setpoint the sampling period <p>Make sure that there is no process disturbance while Auto-Tuning is in progress.</p>
800F hex	Time constant exceeds delay ratio, $\tau/\theta > 20$. <i>PID</i> regulation may no longer be stable. For more details, refer to <i>Limitations on Using the Auto-Tuning</i> , page 176.
8010 hex	Time constant exceeds delay ratio, $\tau/\theta < 2$. <i>PID</i> regulation may no longer be stable. For more details, refer to <i>Limitations on Using the Auto-Tuning</i> , page 176.
8011 hex	The limit for static gain Kp has been exceeded, $K_p > 10000$. Measurement sensitivity of some application variables may be too low. The range must be rescaled within the [0...10000] interval.
8012 hex	The computed value of integral time constant Ti has been exceeded, $T_i > 20000$.
8013 hex	The computed value of derivative time constant Td has been exceeded, $T_d > 10000$.
8014 hex	Invalid input variables value (out of the range defined by low output and high output alarms, page 165).
8015 hex	<p>Filter processing error:</p> <ul style="list-style-type: none"> Cycle time out of range. Filter time < 10 x cycle time

Appendices

What's in This Part

PID Parameters	175
----------------------	-----

Overview

This appendix extracts parts of the programming guide for technical understanding of the library documentation.

PID Parameters

What's in This Chapter

Role and Influence of PID Parameters	175
PID Parameter Adjustment Method.....	176

Role and Influence of PID Parameters

Introduction

This section describes the role and influence of PID parameters.

PID Controller Model

The EcoStruxure Machine Expert - Basic PID Controller implements a mixed (serial-parallel) PID correction. The integral and derivative actions act both independently and in parallel. The proportional action acts on the combined output of the integral and derivative actions.

Computational Algorithms

Two different computational algorithms are used depending on the value of the integral time constant (T_i):

- If $T_i \neq 0$, an incremental algorithm is used,
- If $T_i = 0$, a positional algorithm is used, along with a +5000 offset that is applied to the PID output.

Influence of Actions

Proportional action is used to influence the process response speed. An increase of the proportional action implies:

- a faster response
- a lower static error
- decrease in stability

Integral action is used to cancel out the static error. An increase of integration action (that is, a decrease of the integral time T_i) induces:

- A faster response
- A decrease in stability

Derivative action is anticipatory. In practice, it adds a term which takes account of the speed of variation in the deviation (which makes it possible to anticipate changes by accelerating process response times when the deviation increases and by slowing them down when the deviation decreases). An increase of derivative action (that is, an increase of the derivative time) implies:

- A slower response
- A reduced overshoot

NOTE: Given the derivative time, T_d is the time used to anticipate the variation of the deviation. Values of T_d that are too low or too high can lead to unwanted oscillations.

For each action, a suitable compromise must be found between speed and stability.

Limits of the PID Control Loop

The process is assimilated to a pure delay first order with a transfer function:

$$H(p) = K \times \frac{e^{-\theta p}}{1 + \tau p}$$

where:

τ : model time constant

θ : model delay

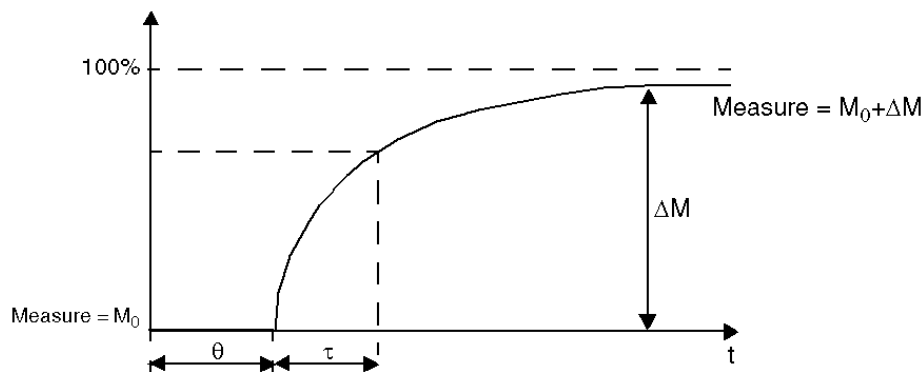

The process control performance depends on the ratio $\frac{\tau}{\theta}$.

The suitable PID process control is attained in the following domain: $2 < \frac{\tau}{\theta} < 20$.

PID process control is best suited for the regulation of processes that satisfy the following condition:

- For $\frac{\tau}{\theta} < 2$, in other words for fast control loops (low θ) or for processes with a large delay (high τ) the PID process control is no longer suitable. In such cases more complex algorithms should be used.
- For $\frac{\tau}{\theta} > 20$, a process control using a threshold plus hysteresis is sufficient.

PID Parameter Adjustment Method

Introduction

Numerous methods to adjust the PID parameters exist. The preferred method is the Ziegler and Nichols, which has 2 variants:

- closed loop adjustment
- open loop adjustment

Before implementing one of these methods, you must set the PID action, page 168.

Closed Loop Adjustment

This principle uses a proportional command ($T_i = 0, T_d = 0$) to start the process by increasing a proportional coefficient until it starts to oscillate again after having applied a level to the PID corrector setpoint. All that is required is to raise the

critical proportional gain (K_{pc}) which has caused the non-damped oscillation and the oscillation period (T_c) to reduce the values giving an optimal regulation.

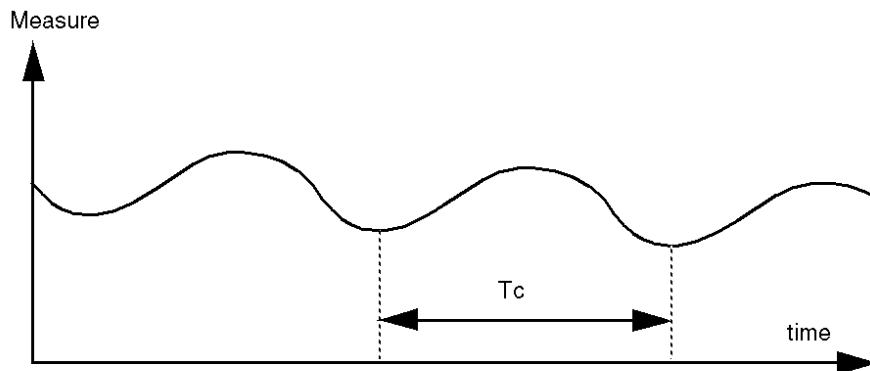

Depending on the corrector type used (PID or PI), the adjustment of the coefficients is executed with the following values:

Corrector	K_p : Proportional Gain	T_i : Integration Time	T_d : Derivative
PID	$K_{pc}/1.7$	$T_c/2$	$T_c/8$
PI	$K_{pc}/2.22$	$0.83 \times T_c$	—

Open Loop Adjustment

As the regulator is in manual mode, page 158, you apply a level to the output and make the procedure response start the same as an integrator with pure delay time.

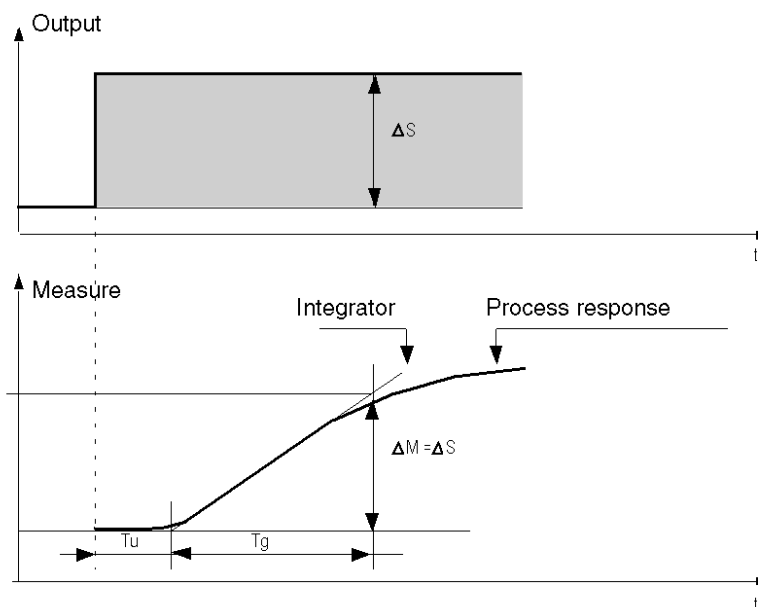

The intersection point on the right hand side, which is representative of the integrator with the time axes, determines the time T_u . Next, the T_g time is defined as the time necessary for the controlled variable (measurement) to have the same variation size (% of the scale) as the regulator output.

Depending on the corrector type used (PID or PI), the adjustment of the coefficients is executed with the following values:

Corrector	Kp: Proportional Gain	Ti: Integration Time	Td: Derivative
PID	-1.2 Tg/Tu	2 x Tu	0.5 x Tu
PI	-0.9 Tg/Tu	3.3 x Tu	–

NOTE: For further details about parameter units, refer to **PID** tab, page 165.

This adjustment method also provides a very dynamic command, which can express itself through unwanted overshoots during the change of pulses of the setpoints. In this case, lower the proportional gain until you get the required behavior. The method does not require any assumptions about the nature and the order of the procedure. You can apply it just as well to the stable procedures as to real integrating procedures. In the case of slow procedures (for example, the glass industry), the user only requires the beginning of the response to regulate the coefficients Kp, Ti, and Td.

Glossary

A

absolute movement:

A movement to a position defined from a reference point.

acceleration / deceleration:

Acceleration is the rate of velocity change, starting from **Start Velocity** to target velocity. Deceleration is the rate of velocity change, starting from target velocity to **Stop Velocity**. These velocity changes are implicitly managed by the PTO function in accordance with acceleration, deceleration, and jerk ratio parameters following a trapezoidal or an S-curve profile.

C

CW/CCW:

ClockWise / Counter ClockWise

D

DWORD:

(*double word*) Encoded in 32-bit format.

F

function:

A programming unit that has 1 input and returns 1 immediate result. However, unlike FBs, it is directly called with its name (as opposed to through an instance), has no persistent state from one call to the next and can be used as an operand in other programming expressions.

Examples: boolean (AND) operators, calculations, conversions (BYTE_TO_INT)

H

homing:

The method used to establish the reference point for absolute movement.

J

jerk ratio:

The proportion of change of the acceleration and deceleration as a function of time.

P

POU:

(*program organization unit*) A variable declaration in source code and a corresponding instruction set. POUs facilitate the modular re-use of software programs, functions, and function blocks. Once declared, POUs are available to one another.

S

S-curve ramp:

An acceleration / deceleration ramp with a `JerkRatio` parameter greater than 0%.

start velocity:

The minimum frequency at which a stepper motor can produce movement, with a load applied, without the loss of steps.

stop velocity:

The maximum frequency at which a stepper motor stops producing movement, with a load applied, without the loss of steps.

T**trapezoidal ramp:**

An acceleration / deceleration ramp with a `JerkRatio` parameter set to 0%.

Index

A

acceleration ramp	78
acknowledging and resetting error	
MC_Reset_ATV	70

B

backlash	82
BUFFER_MODE	101

C

configuring	
Drive function blocks	57

D

deceleration ramp	78
DIRECTION	100
Drive function blocks	
configuring	57
Drive function blocks: error codes	72
%DRV	52

E

enabling/disabling power stage	
MC_Power_ATV	57
error codes	
Drive function blocks	72
error handling	
ErrID	21
Error	21

F

fast counter	
configuration	24
description	23
programming example	26
%FC	23
FREQGEN	
function block	145
function block configuration	146
frequency generator	
function block	145
Function Block Object Codes	
BUFFER_MODE	101
DIRECTION	100
HOMING_MODE	101
PTO_PARAMETER	101
function blocks	
FC (Fast Counter)	23
frequency generator (%FREQGEN)	145
HSC (high speed counter)	28
MC_Halt_PTO	128
MC_Home_PTO	123
MC_Jog_ATV	59
MC_Motion_PTO	108
MC_MoveAbs_PTO	120
MC_MoveRel_PTO	117
MC_MoveVel_ATV	62

MC_MoveVel_PTO	114
MC_Power_ATV	57
MC_Power_PTO	111
MC_ReadMotionState_ATV	68
MC_ReadStatus_ATV	66
MC_Reset_ATV	70
MC_SetPost_PTO	125
MC_Stop_ATV	64
MC_Stop_PTO	126
MV_AbortTrigger_PTO	141
MV_ReadActPos_PTO	132
MV_ReadActVel_PTO	130
MV_ReadAxis_PTO	136
MV_ReadMotionState_PTO	135
MV_ReadPar_PTO	142
MV_ReadSts_PTO	133
MV_Reset_PTO	138
MV_TouchProbe_PTO	139
MV_WritePar_PTO	143
pulse	41
pulse width modulation	47
functionalities	
PTO	75

H

high speed counter	
counting mode	32
description	28
frequency meter mode	38
HOMING_MODE	101
%HSC	
high speed counter	28

J

JerkRatio	78
-----------------	----

M

management of Function Block Inputs and Input Objects	
Execute	21
management of Function Block Outputs and Output Objects	
Busy	21
CmdAborted	21
Done	21
ErrID	21
Error	21
MC_Halt_PTO	
controlled motion stop until velocity is 0	128
MC_Home_PTO	
command axis to perform homing sequence	123
MC_Jog_ATV	
starting jog mode	59
MC_Motion_PTO	
calling a Motion Task Table	108
MC_MoveAbs_PTO	
moving axis to a given position at specified speed	120
MC_MoveRel_PTO	
moving axis an incremental distance at specified speed	117
MC_MoveVel_ATV	
moving at specified velocity	62
MC_MoveVel_PTO	

moving an axis at specified speed	114	description.....	41
MC_Power_ATV		function block configuration	42
enabling/disabling power stage	57	programming example.....	46
MC_Power_PTO		pulse width modulation	
enabling power to an axis	111	description.....	47
MC_ReadMotionState_ATV		function block configuration	48
reading motion state.....	68	programming example.....	51
MC_ReadStatus_ATV		%PWM	47
reading device status	66		
MC_Reset_ATV			
acknowledging and resetting error.....	70		
MC_SetPost_PTO			
moving axis to specified position	125		
MC_Stop_ATV			
stopping movement.....	64		
MC_Stop_PTO			
commanding a controlled motion stop.....	126		
motion task table			
PTO	85		
moving at specified velocity			
MC_MoveVel_ATV	62		
MV_AbortTrigger_PTO			
aborting function blocks connected to trigger			
events	141		
MV_ReadActPos_PTO			
getting the position of the axis	132		
MV_ReadActVel_PTO			
getting the velocity of the axis	130		
MV_ReadAxisError_PTO			
getting an axis control error.....	136		
MV_ReadMotionState_PTO			
getting the motion status of the axis.....	135		
MV_ReadPar_PTO			
getting parameters from the PTO	142		
MV_ReadSts_PTO			
getting the status of the axis.....	133		
MV_Reset_PTO			
resetting axis-related errors	138		
MV_TouchProbe_PTO			
activating a trigger event on probe input.....	139		
MV_WritePar_PTO			
writing parameters to the PTO.....	143		
P			
PID			
AT tab	167		
auto-tuning	150		
closed loop adjustment.....	176		
configuration assistant.....	162		
description.....	170		
general tab	163		
Input tab	164		
open loop adjustment	177		
operating modes	149		
output tab	168		
parameter.....	175		
PID tab.....	165		
programming and configuring.....	171		
standard configuration.....	153		
states and detected error codes	172		
%PLS.....	41		
PTO			
configuration.....	85		
functionalities.....	75		
motion task table.....	85		
PTO_ERROR	102–103		
PTO_PARAMETER.....	101		
pulse			

Schneider Electric
35 rue Joseph Monier
92500 Rueil Malmaison
France

+ 33 (0) 1 41 29 70 00

www.se.com

As standards, specifications, and design change from time to time,
please ask for confirmation of the information given in this publication.

© 2022 Schneider Electric. All rights reserved.

EIO0000003305.02

Modicon M221 Logic Controller

Hardware Guide

EIO0000003313.03
03/2024



Legal Information

The information provided in this document contains general descriptions, technical characteristics and/or recommendations related to products/solutions.

This document is not intended as a substitute for a detailed study or operational and site-specific development or schematic plan. It is not to be used for determining suitability or reliability of the products/solutions for specific user applications. It is the duty of any such user to perform or have any professional expert of its choice (integrator, specifier or the like) perform the appropriate and comprehensive risk analysis, evaluation and testing of the products/solutions with respect to the relevant specific application or use thereof.

The Schneider Electric brand and any trademarks of Schneider Electric SE and its subsidiaries referred to in this document are the property of Schneider Electric SE or its subsidiaries. All other brands may be trademarks of their respective owner.

This document and its content are protected under applicable copyright laws and provided for informative use only. No part of this document may be reproduced or transmitted in any form or by any means (electronic, mechanical, photocopying, recording, or otherwise), for any purpose, without the prior written permission of Schneider Electric.

Schneider Electric does not grant any right or license for commercial use of the document or its content, except for a non-exclusive and personal license to consult it on an "as is" basis.

Schneider Electric reserves the right to make changes or updates with respect to or in the content of this document or the format thereof, at any time without notice.

To the extent permitted by applicable law, no responsibility or liability is assumed by Schneider Electric and its subsidiaries for any errors or omissions in the informational content of this document, as well as any non-intended use or misuse of the content thereof.

Table of Contents

Safety Information	7
Qualification of Personnel	7
Intended Use	8
About the Book	9
Modicon M221 Logic Controller Introduction	15
M221 General Overview	16
TM221C Logic Controller Description	17
TM221M Logic Controller Description	21
Maximum Hardware Configuration	25
TM2 Expansion Modules	29
TM3 Expansion Modules	32
TM3 Bus Couplers	39
TMC2 Cartridges	40
Accessories	41
M221 Features	44
Real Time Clock (RTC)	44
Input Management	48
Output Management	50
Run/Stop	53
SD Card	55
M221 Installation	60
M221 Logic Controller General Rules for Implementing	60
Environmental Characteristics	60
Certifications and Standards	62
M221 Logic Controller Installation	63
Installation and Maintenance Requirements	63
TM221C Logic Controller Mounting Positions and Clearances	64
TM221M Logic Controller Mounting Positions and Clearances	66
Top Hat Section Rail (DIN rail)	69
Installing and Removing the Controller with Expansions	71
Direct Mounting on a Panel Surface	73
M221 Electrical Requirements	74
Wiring Best Practices	74
DC Power Supply Characteristics and Wiring	79
AC Power Supply Characteristics and Wiring	82
Grounding the M221 System	85
Modicon TM221C Logic Controller	88
TM221C16R	89
TM221C16R Presentation	89
TM221CE16R	92
TM221CE16R Presentation	92
TM221C16T	95
TM221C16T Presentation	95
TM221CE16T	98
TM221CE16T Presentation	98
TM221C16U	101

TM221C16U Presentation	101
TM221CE16U	104
TM221CE16U Presentation	104
TM221C24R	107
TM221C24R Presentation	107
TM221CE24R	110
TM221CE24R Presentation	110
TM221C24T	113
TM221C24T Presentation	113
TM221CE24T	116
TM221CE24T Presentation	116
TM221C24U	119
TM221C24U Presentation	119
TM221CE24U	122
TM221CE24U Presentation	122
TM221C40R	125
TM221C40R Presentation	125
TM221CE40R	129
TM221CE40R Presentation	129
TM221C40T	133
TM221C40T Presentation	133
TM221CE40T	137
TM221CE40T Presentation	137
TM221C40U	141
TM221C40U Presentation	141
TM221CE40U	144
TM221CE40U Presentation	144
Embedded I/O Channels	147
Digital Inputs	147
Relay Outputs	160
Regular and Fast Transistor Outputs	166
Analog Inputs	174
Modicon TM221M Logic Controller	177
TM221M16R / TM221M16RG	178
TM221M16R / TM221M16RG Presentation	178
TM221M16R / TM221M16RG Digital Inputs	181
TM221M16R / TM221M16RG Digital Outputs	184
TM221M16R / TM221M16RG Analog Inputs	187
TM221ME16R / TM221ME16RG	190
TM221ME16R / TM221ME16RG Presentation	190
TM221ME16R / TM221ME16RG Digital Inputs	193
TM221ME16R / TM221ME16RG Digital Outputs	196
TM221ME16R / TM221ME16RG Analog Inputs	199
TM221M16T / TM221M16TG	202
TM221M16T / TM221M16TG Presentation	202
TM221M16T / TM221M16TG Digital Inputs	205
TM221M16T / TM221M16TG Digital Outputs	209
TM221M16T / TM221M16TG Analog Inputs	213
TM221ME16T / TM221ME16TG	216
TM221ME16T / TM221ME16TG Presentation	216
TM221ME16T / TM221ME16TG Digital Inputs	219

TM221ME16T / TM221ME16TG Digital Outputs.....	223
TM221ME16T / TM221ME16TG Analog Inputs	226
TM221M32TK	229
TM221M32TK Presentation	229
TM221M32TK Digital Inputs	232
TM221M32TK Digital Outputs	235
TM221M32TK Analog Inputs	239
TM221ME32TK.....	242
TM221ME32TK Presentation.....	242
TM221ME32TK Digital Inputs	245
TM221ME32TK Digital Outputs.....	249
TM221ME32TK Analog Inputs	253
Modicon M221 Logic Controller Communication	256
Integrated Communication Ports.....	257
USB Mini-B Programming Port.....	257
Ethernet Port	258
Serial Line 1	260
Serial Line 2	263
Connecting the M221 Logic Controller to a PC	266
Connecting the Controller to a PC	266
Glossary	269
Index	273

Safety Information

Important Information

Read these instructions carefully, and look at the equipment to become familiar with the device before trying to install, operate, service, or maintain it. The following special messages may appear throughout this documentation or on the equipment to warn of potential hazards or to call attention to information that clarifies or simplifies a procedure.





The addition of this symbol to a “Danger” or “Warning” safety label indicates that an electrical hazard exists which will result in personal injury if the instructions are not followed.



This is the safety alert symbol. It is used to alert you to potential personal injury hazards. Obey all safety messages that follow this symbol to avoid possible injury or death.

 DANGER
DANGER indicates a hazardous situation which, if not avoided, will result in death or serious injury.

 WARNING
WARNING indicates a hazardous situation which, if not avoided, could result in death or serious injury.

 CAUTION
CAUTION indicates a hazardous situation which, if not avoided, could result in minor or moderate injury.

NOTICE
NOTICE is used to address practices not related to physical injury.

Please Note

Electrical equipment should be installed, operated, serviced, and maintained only by qualified personnel. No responsibility is assumed by Schneider Electric for any consequences arising out of the use of this material.

A qualified person is one who has skills and knowledge related to the construction and operation of electrical equipment and its installation, and has received safety training to recognize and avoid the hazards involved.

Qualification of Personnel

Only appropriately trained persons who are familiar with and understand the contents of this manual and all other pertinent product documentation are authorized to work on and with this product.

The qualified person must be able to detect possible hazards that may arise from parameterization, modifying parameter values and generally from mechanical, electrical, or electronic equipment. The qualified person must be familiar with the standards, provisions, and regulations for the prevention of industrial accidents, which they must observe when designing and implementing the system.

Intended Use

The products described or affected by this document, together with software, accessories, and options, are programmable logic controllers (referred to herein as "logic controllers"), intended for industrial use according to the instructions, directions, examples, and safety information contained in the present document and other supporting documentation.

The product may only be used in compliance with all applicable safety regulations and directives, the specified requirements, and the technical data.

Prior to using the product, you must perform a risk assessment in view of the planned application. Based on the results, the appropriate safety-related measures must be implemented.

Since the product is used as a component in an overall machine or process, you must ensure the safety of persons by means of the design of this overall system.

Operate the product only with the specified cables and accessories. Use only genuine accessories and spare parts.

Any use other than the use explicitly permitted is prohibited and can result in unanticipated hazards.

About the Book

Document Scope

Use this document to:

- Install and operate your M221 Logic Controller.
- Connect the M221 Logic Controller to a programming device equipped with EcoStruxure Machine Expert - Basic software.
- Interface the M221 Logic Controller with I/O expansion modules, HMI and other devices.
- Familiarize yourself with the M221 Logic Controller features.

NOTE: Read and understand this document and all related documents, page 10 before installing, operating, or maintaining your controller.

Validity Note

This document has been updated for the release of EcoStruxure™ Machine Expert - Basic V1.3.

For product compliance and environmental information (RoHS, REACH, PEP, EOL, etc.), go to www.se.com/ww/en/work/support/green-premium/.

The characteristics of the products described in this document are intended to match the characteristics that are available on www.se.com. As part of our corporate strategy for constant improvement, we may revise the content over time to enhance clarity and accuracy. If you see a difference between the characteristics in this document and the characteristics on www.se.com, consider www.se.com to contain the latest information.

Available Languages of this Document

This document is available in these languages:

- English (EIO0000003313)
- French (EIO0000003314)
- German (EIO0000003315)
- Spanish (EIO0000003316)
- Italian (EIO0000003317)
- Chinese (EIO0000003318)
- Portuguese (EIO0000003319)
- Turkish (EIO0000003320)

Related Documents

Title of Documentation	Reference Number
Modicon M221 Logic Controller- Programming Guide	EIO0000003297 (ENG) EIO0000003298 (FRE) EIO0000003299 (GER) EIO0000003300 (SPA) EIO0000003301 (ITA) EIO0000003302 (CHS) EIO0000003304 (TUR) EIO0000003303 (POR)
Modicon TMH2GDB Remote Graphic Display - User Guide	EIO0000003321 (ENG) EIO0000003322 (FRE) EIO0000003323 (GER) EIO0000003324 (SPA) EIO0000003325 (ITA) EIO0000003326 (CHS) EIO0000003328 (TUR) EIO0000003327 (POR)
Modicon TMC2 Cartridge - Programming Guide	EIO0000003329 (ENG) EIO0000003330 (FRE) EIO0000003331 (GER) EIO0000003332 (SPA) EIO0000003333 (ITA) EIO0000003334 (CHS) EIO0000003335 (POR) EIO0000003336 (TUR)
Modicon TMC2 Cartridges - Hardware Guide	EIO0000003337 (ENG) EIO0000003338 (FRE) EIO0000003339 (GER) EIO0000003340 (SPA) EIO0000003341 (ITA) EIO0000003342 (CHS) EIO0000003344 (TUR) EIO0000003343 (POR)
Modicon TM3 Expansion Modules Configuration - Programming Guide (EcoStruxure Machine Expert - Basic)	EIO0000003345 (ENG) EIO0000003346 (FRE) EIO0000003347 (GER) EIO0000003348 (SPA) EIO0000003349 (ITA) EIO0000003350 (CHS) EIO0000003351 (POR) EIO0000003352 (TUR)

Title of Documentation	Reference Number
Modicon TM3 Digital I/O Modules - Hardware Guide	EIO0000003125 (ENG) EIO0000003126 (FRE) EIO0000003127 (GER) EIO0000003128 (SPA) EIO0000003129 (ITA) EIO0000003130 (CHS) EIO0000003425 (TUR) EIO0000003424 (POR)
Modicon TM3 Analog I/O Modules - Hardware Guide	EIO0000003131 (ENG) EIO0000003132 (FRE) EIO0000003133 (GER) EIO0000003134 (SPA) EIO0000003135 (ITA) EIO0000003136 (CHS) EIO0000003427 (TUR) EIO0000003426 (POR)
Modicon TM3 Expert I/O Modules - Hardware Guide	EIO0000003137 (ENG) EIO0000003138 (FRE) EIO0000003139 (GER) EIO0000003140 (SPA) EIO0000003141 (ITA) EIO0000003142 (CHS) EIO0000003429 (TUR) EIO0000003428 (POR)
Modicon TM3 Safety Modules - Hardware Guide	EIO0000003353 (ENG) EIO0000003354 (FRE) EIO0000003355 (GER) EIO0000003356 (SPA) EIO0000003357 (ITA) EIO0000003358 (CHS) EIO0000003360 (TUR) EIO0000003359 (POR)
Modicon TM3 Transmitter and Receiver Modules - Hardware Guide	EIO0000003143 (ENG) EIO0000003144 (FRE) EIO0000003145 (GER) EIO0000003146 (SPA) EIO0000003147 (ITA) EIO0000003148 (CHS) EIO0000003431 (TUR) EIO0000003430 (POR)

Title of Documentation	Reference Number
Modicon TM3 Bus Coupler Module - Hardware Guide	EIO0000003635 (ENG)
	EIO0000003636 (FRE)
	EIO0000003637 (GER)
	EIO0000003638 (SPA)
	EIO0000003639 (ITA)
	EIO0000003640 (CHS)
	EIO0000003641 (POR)
	EIO0000003642 (TUR)
TM221C DC Logic Controller - Instruction Sheet	EAV48550
TM221C AC Logic Controller - Instruction Sheet	EAV58623
TM221M Logic Controller - Instruction Sheet	HRB59602

To find documents online, visit the Schneider Electric download center (www.se.com/ww/en/download/).

Product Related Information

DANGER

HAZARD OF ELECTRIC SHOCK, EXPLOSION OR ARC FLASH

- Disconnect all power from all equipment including connected devices prior to removing any covers or doors, or installing or removing any accessories, hardware, cables, or wires except under the specific conditions specified in the appropriate hardware guide for this equipment.
- Always use a properly rated voltage sensing device to confirm the power is off where and when indicated.
- Replace and secure all covers, accessories, hardware, cables, and wires and confirm that a proper ground connection exists before applying power to the unit.
- Use only the specified voltage when operating this equipment and any associated products.

Failure to follow these instructions will result in death or serious injury.

DANGER

POTENTIAL FOR EXPLOSION

- Only use this equipment in non-hazardous locations, or in locations that comply with Class I, Division 2, Groups A, B, C and D.
- Do not substitute components which would impair compliance to Class I, Division 2.
- Do not connect or disconnect equipment unless power has been removed or the location is known to be non-hazardous.
- Do not use the USB port(s), if so equipped, unless the location is known to be non-hazardous.

Failure to follow these instructions will result in death or serious injury.

▲ WARNING
<p>LOSS OF CONTROL</p> <ul style="list-style-type: none"> • Perform a Failure Mode and Effects Analysis (FMEA), or equivalent risk analysis, of your application, and apply preventive and detective controls before implementation. • Provide a fallback state for undesired control events or sequences. • Provide separate or redundant control paths wherever required. • Supply appropriate parameters, particularly for limits. • Review the implications of transmission delays and take actions to mitigate them. • Review the implications of communication link interruptions and take actions to mitigate them. • Provide independent paths for control functions (for example, emergency stop, over-limit conditions, and error conditions) according to your risk assessment, and applicable codes and regulations. • Apply local accident prevention and safety regulations and guidelines.¹ • Test each implementation of a system for proper operation before placing it into service. <p>Failure to follow these instructions can result in death, serious injury, or equipment damage.</p>

¹ For additional information, refer to NEMA ICS 1.1 (latest edition), *Safety Guidelines for the Application, Installation, and Maintenance of Solid State Control* and to NEMA ICS 7.1 (latest edition), *Safety Standards for Construction and Guide for Selection, Installation and Operation of Adjustable-Speed Drive Systems* or their equivalent governing your particular location.

▲ WARNING
<p>UNINTENDED EQUIPMENT OPERATION</p> <ul style="list-style-type: none"> • Only use software approved by Schneider Electric for use with this equipment. • Update your application program every time you change the physical hardware configuration. <p>Failure to follow these instructions can result in death, serious injury, or equipment damage.</p>

Information on Non-Inclusive or Insensitive Terminology

As a responsible, inclusive company, Schneider Electric is constantly updating its communications and products that contain non-inclusive or insensitive terminology. However, despite these efforts, our content may still contain terms that are deemed inappropriate by some customers.

Terminology Derived from Standards

The technical terms, terminology, symbols and the corresponding descriptions in the information contained herein, or that appear in or on the products themselves, are generally derived from the terms or definitions of international standards.

In the area of functional safety systems, drives and general automation, this may include, but is not limited to, terms such as *safety*, *safety function*, *safe state*, *fault*, *fault reset*, *malfunction*, *failure*, *error*, *error message*, *dangerous*, etc.

Among others, these standards include:

Standard	Description
IEC 61131-2:2007	Programmable controllers, part 2: Equipment requirements and tests.
ISO 13849-1:2023	Safety of machinery: Safety related parts of control systems. General principles for design.
EN 61496-1:2013	Safety of machinery: Electro-sensitive protective equipment. Part 1: General requirements and tests.
ISO 12100:2010	Safety of machinery - General principles for design - Risk assessment and risk reduction
EN 60204-1:2006	Safety of machinery - Electrical equipment of machines - Part 1: General requirements
ISO 14119:2013	Safety of machinery - Interlocking devices associated with guards - Principles for design and selection
ISO 13850:2015	Safety of machinery - Emergency stop - Principles for design
IEC 62061:2021	Safety of machinery - Functional safety of safety-related electrical, electronic, and electronic programmable control systems
IEC 61508-1:2010	Functional safety of electrical/electronic/programmable electronic safety-related systems: General requirements.
IEC 61508-2:2010	Functional safety of electrical/electronic/programmable electronic safety-related systems: Requirements for electrical/electronic/programmable electronic safety-related systems.
IEC 61508-3:2010	Functional safety of electrical/electronic/programmable electronic safety-related systems: Software requirements.
IEC 61784-3:2021	Industrial communication networks - Profiles - Part 3: Functional safety fieldbuses - General rules and profile definitions.
2006/42/EC	Machinery Directive
2014/30/EU	Electromagnetic Compatibility Directive
2014/35/EU	Low Voltage Directive

In addition, terms used in the present document may tangentially be used as they are derived from other standards such as:

Standard	Description
IEC 60034 series	Rotating electrical machines
IEC 61800 series	Adjustable speed electrical power drive systems
IEC 61158 series	Digital data communications for measurement and control – Fieldbus for use in industrial control systems

Finally, the term *zone of operation* may be used in conjunction with the description of specific hazards, and is defined as it is for a *hazard zone* or *danger zone* in the *Machinery Directive (2006/42/EC)* and *ISO 12100:2010*.

NOTE: The aforementioned standards may or may not apply to the specific products cited in the present documentation. For more information concerning the individual standards applicable to the products described herein, see the characteristics tables for those product references.

Modicon M221 Logic Controller Introduction

What's in This Part

M221 General Overview	16
M221 Features.....	44
M221 Installation	60

M221 General Overview

What's in This Chapter

TM221C Logic Controller Description.....	17
TM221M Logic Controller Description	21
Maximum Hardware Configuration.....	25
TM2 Expansion Modules.....	29
TM3 Expansion Modules.....	32
TM3 Bus Couplers.....	39
TMC2 Cartridges.....	40
Accessories	41

Overview

This chapter provides general information about the M221 Logic Controller system architecture and its components.

TM221C Logic Controller Description

Overview

The TM221C Logic Controller has various powerful features and can service a wide range of applications.

Software configuration, programming, and commissioning are accomplished with the EcoStruxure Machine Expert - Basic software described in the EcoStruxure Machine Expert - Basic Operating Guide (see EcoStruxure Machine Expert - Basic, Operating Guide) and the M221 Logic Controller - Programming Guide (see Modicon M221, Logic Controller, Programming Guide).

Programming Languages

The M221 Logic Controller is configured and programmed with the EcoStruxure Machine Expert - Basic software, which supports the following IEC 61131-3 programming languages:

- IL: Instruction List
- LD: Ladder Diagram
- Grafcet (List)
- Grafcet (SFC)

Power Supply

The power supply of the TM221C Logic Controller is 24 Vdc, page 79 or 100...240 Vac, page 82.

Real Time Clock

The M221 Logic Controller includes a Real Time Clock (RTC) system, page 44.

Run/Stop

The M221 Logic Controller can be operated externally by the following:

- a hardware Run/Stop switch, page 53
- a Run/Stop, page 53 operation by a dedicated digital input, defined in the software configuration. For more information, refer to Configuring Digital Inputs (see Modicon M221, Logic Controller, Programming Guide).
- EcoStruxure Machine Expert - Basic software. For more information, refer to Toolbar (see EcoStruxure Machine Expert - Basic, Operating Guide).
- a TMH2GDB Remote Graphic Display. For more information, refer to Controller State Menu (see Modicon TMH2GDB, Remote Graphic Display, User Guide).

Memory

This table describes the different types of memory:

Memory Type	Size	Used to
RAM	512 kbytes of RAM memory: 256 kbytes for internal variables and 256 kbytes for application and data.	execute the application and contain data
Non-volatile	1.5 Mbytes, of which 256 kbytes is used to back up the application and data in case of power outage.	save the application

Embedded Inputs/Outputs

The following embedded I/O types are available, depending on the controller reference:

- Regular inputs
- Fast inputs associated with counters
- Regular sink/source transistor outputs
- Fast sink/source transistor outputs associated with pulse generators
- Relay outputs
- Analog inputs

Removable Storage

The M221 Logic Controller includes an embedded SD card slot, page 55.

The Modicon M221 Logic Controller allows the following types of file management with an SD card:

- Clone management (see Modicon M221, Logic Controller, Programming Guide): back up the application, firmware, and post configuration (if it exists) of the logic controller
- Firmware management (see Modicon M221, Logic Controller, Programming Guide): download firmware to the logic controller, to a TMH2GDB Remote Graphic Display , or to TM3 expansion modules
- Application management (see Modicon M221, Logic Controller, Programming Guide): back up and restore the logic controller application, or copy it to another logic controller of the same reference
- Post configuration management (see Modicon M221, Logic Controller, Programming Guide): add, change, or delete the post configuration file of the logic controller
- Error log management (see Modicon M221, Logic Controller, Programming Guide): back up or delete the error log file of the logic controller
- Memory management: back up and restore memory bits and words from a controller

Embedded Communication Features

The following types of communication ports are available depending on the controller reference:

- Ethernet, page 258
- USB Mini-B, page 257
- Serial Line 1, page 260

Remote Graphic Display

For more information, refer to the Modicon TMH2GDB Remote Graphic Display - User Guide.

TM221C Logic Controller

Reference	Digital Inputs	Digital Outputs	Analog Inputs	Communication Ports	Power Supply
TM221C16R, page 89	5 regular inputs ⁽¹⁾ 4 fast inputs (HSC) ⁽²⁾	7 relay outputs	Yes	1 serial line port 1 USB programming port	100...240 Vac
TM221CE16R, page 92			Yes	1 serial line port 1 USB programming port 1 Ethernet port	
TM221C16T, page 95	5 regular inputs ⁽¹⁾ 4 fast inputs (HSC) ⁽²⁾	Source outputs	Yes	1 serial line port 1 USB programming port	24 Vdc
TM221CE16T, page 98		5 regular transistor outputs 2 fast outputs (PLS/PWM/PTO/ FREQGEN) ⁽³⁾	Yes	1 serial line port 1 USB programming port 1 Ethernet port	
TM221C16U, page 101	5 regular inputs ⁽¹⁾ 4 fast inputs (HSC) ⁽²⁾	Sink outputs	Yes	1 serial line port 1 USB programming port	24 Vdc
TM221CE16U, page 104		5 regular transistor outputs 2 fast outputs (PLS/PWM/PTO/ FREQGEN) ⁽³⁾		1 serial line port 1 USB programming port 1 Ethernet port	
TM221C24R, page 107	10 regular inputs ⁽¹⁾ 4 fast inputs (HSC) ⁽²⁾	10 relay outputs	Yes	1 serial line port 1 USB programming port	100...240 Vac
TM221CE24R, page 110			Yes	1 serial line port 1 USB programming port 1 Ethernet port	
TM221C24T, page 113		Source outputs	Yes	1 serial line port 1 USB programming port	24 Vdc
TM221CE24T, page 116	8 regular transistor outputs 2 fast outputs (PLS/PWM/PTO/ FREQGEN) ⁽³⁾	Yes	1 serial line port 1 USB programming port 1 Ethernet port		
TM221C24U, page 119	10 regular inputs ⁽¹⁾ 4 fast inputs (HSC) ⁽²⁾	Sink outputs	Yes	1 serial line port 1 USB programming port	24 Vdc
TM221CE24U, page 122		8 regular transistor outputs 2 fast outputs (PLS/PWM/PTO/ FREQGEN) ⁽³⁾	Yes	1 serial line port 1 USB programming port 1 Ethernet port	

Reference	Digital Inputs	Digital Outputs	Analog Inputs	Communication Ports	Power Supply
TM221C40R, page 125	20 regular inputs ⁽¹⁾ 4 fast inputs (HSC) ⁽²⁾	16 relay outputs	Yes	1 serial line port 1 USB programming port	100...240 Vac
TM221CE40R, page 129			Yes	1 serial line port 1 USB programming port 1 Ethernet port	
TM221C40T, page 133		Source outputs 14 regular transistor outputs	Yes	1 serial line port 1 USB programming port	24 Vdc
TM221CE40T, page 137		2 fast outputs (PLS/PWM/PTO/ FREQGEN) ⁽³⁾	Yes	1 serial line port 1 USB programming port 1 Ethernet port	
TM221C40U, page 141	20 regular inputs ⁽¹⁾ 4 fast inputs (HSC) ⁽²⁾	Sink outputs 12 regular transistor outputs	Yes	1 serial line port 1 USB programming port	24 Vdc
TM221CE40U, page 144		4 fast outputs (PLS/PWM/PTO/ FREQGEN) ⁽³⁾	Yes	1 serial line port 1 USB programming port 1 Ethernet port	

NOTE: The TM221C Logic Controller uses removable screw terminal blocks.

(1) The regular inputs have a maximum frequency of 5 kHz.

(2) The fast inputs can be used either as regular inputs or as fast inputs for counting or event functions.

(3) The fast transistor outputs can be used either as regular transistor outputs, for PLS, PWM, PTO, or FREQGEN functions, or reflex outputs for HSC.

Delivery Content

The following figure presents the content of the delivery for a TM221C Logic Controller:

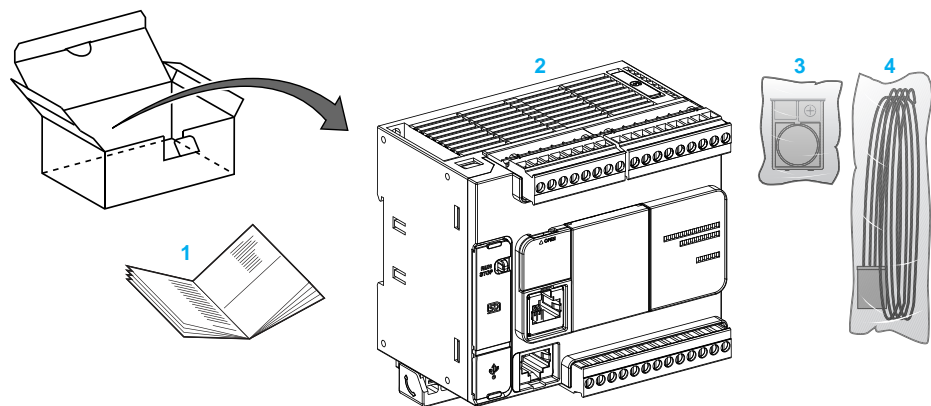

1 TM221C Logic Controller Instruction Sheet

2 TM221C Logic Controller

3 Battery holder with lithium coin battery, type Panasonic BR2032 or Murata CR2032X.

4 Analog cable

TM221M Logic Controller Description

Overview

The TM221M Logic Controller has various powerful features and can service a wide range of applications.

Software configuration, programming, and commissioning are accomplished with the EcoStruxure Machine Expert - Basic software described in the EcoStruxure Machine Expert - Basic Operating Guide (see EcoStruxure Machine Expert - Basic, Operating Guide) and the M221 Logic Controller - Programming Guide (see Modicon M221, Logic Controller, Programming Guide).

Programming Languages

The M221 Logic Controller is configured and programmed with the EcoStruxure Machine Expert - Basic software, which supports the following IEC 61131-3 programming languages:

- IL: Instruction List
- LD: Ladder Diagram
- Grafcet (List)
- Grafcet (SFC)

Power Supply

The power supply of the TM221M Logic Controller is 24 Vdc, page 79.

Real Time Clock

The M221 Logic Controller includes a Real Time Clock (RTC) system, page 44.

Run/Stop

The M221 Logic Controller can be operated externally by the following:

- a hardware Run/Stop switch, page 53
- a Run/Stop, page 53 operation by a dedicated digital input, defined in the software configuration. For more information, refer to Configuring Digital Inputs (see Modicon M221, Logic Controller, Programming Guide).
- EcoStruxure Machine Expert - Basic software. For more information, refer to Toolbar (see EcoStruxure Machine Expert - Basic, Operating Guide).
- a TMH2GDB Remote Graphic Display. For more information, refer to Controller State Menu (see Modicon TMH2GDB, Remote Graphic Display, User Guide).

Memory

This table describes the different types of memory:

Memory Type	Size	Used to
RAM	512 kbytes of RAM memory: 256 kbytes for internal variables and 256 kbytes for application and data.	execute the application and contains data
Non-volatile	1.5 Mbytes, of which 256 kbytes is used to back up the application and data in case of power outage.	save the application

Embedded Inputs/Outputs

The following embedded I/O types are available, depending on the controller reference:

- Regular inputs
- Fast inputs (HSC)
- Regular transistor outputs
- Fast transistor outputs (PLS/PWM/PTO/FREQGEN)
- Relay outputs
- Analog inputs

Removable Storage

The M221 Logic Controller includes an embedded SD card slot, page 55.

The Modicon M221 Logic Controller allows the following types of file management with an SD card:

- Clone management (see Modicon M221, Logic Controller, Programming Guide): back up the application, firmware, and post configuration (if it exists) of the logic controller
- Firmware management (see Modicon M221, Logic Controller, Programming Guide): download firmware updates directly to the logic controller, and download firmware to a TMH2GDB Remote Graphic Display
- Application management (see Modicon M221, Logic Controller, Programming Guide): back up and restore the logic controller application, or copy it to another logic controller of the same reference
- Post configuration management (see Modicon M221, Logic Controller, Programming Guide): add, change, or delete the post configuration file of the logic controller
- Error log management (see Modicon M221, Logic Controller, Programming Guide): back up or delete the error log file of the logic controller
- Memory management: backup/restore of memory bits and words from a controller

Embedded Communication Features

The following communication ports are available on the front panel of the controller, depending on the controller reference:

- Ethernet, page 258
- USB Mini-B, page 257
- SD Card, page 55
- Serial Line 1, page 260
- Serial Line 2, page 263

Remote Graphic Display

For more information, refer to the Modicon TMH2GDB Remote Graphic Display - User Guide.

TM221M Logic Controller

Reference	Digital Input	Digital Output	Analog Input	Communication Ports	Terminal Type
TM221M16R, page 178	4 regular inputs ⁽¹⁾ 4 fast inputs (HSC) ⁽²⁾	8 relay outputs	Yes	2 serial line ports 1 USB programming port	Removable screw terminal blocks
TM221M16RG, page 178	4 regular inputs ⁽¹⁾ 4 fast inputs (HSC) ⁽²⁾	8 relay outputs	Yes	2 serial line ports 1 USB programming port	Removable spring terminal blocks
TM221ME16R, page 190	4 regular inputs ⁽¹⁾ 4 fast inputs (HSC) ⁽²⁾	8 relay outputs	Yes	1 serial line port 1 USB programming port 1 Ethernet port	Removable screw terminal blocks
TM221ME16RG, page 190	4 regular inputs ⁽¹⁾ 4 fast inputs (HSC) ⁽²⁾	8 relay outputs	Yes	1 serial line port 1 USB programming port 1 Ethernet port	Removable spring terminal blocks
TM221M16T, page 202	4 regular inputs ⁽¹⁾ 4 fast inputs (HSC) ⁽²⁾	6 regular transistor outputs 2 fast transistor outputs (PLS/PWM/PTO/FREQGEN) ⁽³⁾	Yes	2 serial line ports 1 USB programming port	Removable screw terminal blocks
TM221M16TG, page 202	4 regular inputs ⁽¹⁾ 4 fast inputs (HSC) ⁽²⁾	6 regular transistor outputs 2 fast transistor outputs (PLS/PWM/PTO/FREQGEN) ⁽³⁾	Yes	2 serial line ports 1 USB programming port	Removable spring terminal blocks
TM221ME16T, page 216	4 regular inputs ⁽¹⁾ 4 fast inputs (HSC) ⁽²⁾	6 regular transistor outputs 2 fast transistor outputs (PLS/PWM/PTO/FREQGEN) ⁽³⁾	Yes	1 serial line port 1 USB programming port 1 Ethernet port	Removable screw terminal blocks
TM221ME16TG, page 216	4 regular inputs ⁽¹⁾ 4 fast inputs (HSC) ⁽²⁾	6 regular transistor outputs 2 fast transistor outputs (PLS/PWM/PTO/FREQGEN) ⁽³⁾	Yes	1 serial line port USB programming port 1 Ethernet port	Removable spring terminal blocks

Reference	Digital Input	Digital Output	Analog Input	Communication Ports	Terminal Type
TM221M32TK, page 229	12 regular inputs ⁽¹⁾ 4 fast inputs (HSC) ⁽²⁾	14 regular transistor outputs 2 fast outputs (PLS/ PWM/PTO/ FREQGEN) ⁽³⁾	Yes	2 serial line ports 1 USB programming port	HE10 (MIL 20) connectors
TM221ME32TK, page 229	12 regular inputs ⁽¹⁾ 4 fast inputs (HSC) ⁽²⁾	14 regular outputs 2 fast outputs (PLS/ PWM/PTO/ FREQGEN) ⁽³⁾	Yes	1 serial line port 1 USB programming port 1 Ethernet port	HE10 (MIL 20) connectors

NOTE: The TM221M Logic Controller uses a 24 Vdc power supply, page 79.

(1) The regular inputs I2, I3, I4, and I5 have a maximum frequency of 5 kHz. The other regular inputs have a maximum frequency of 100 Hz.

(2) The fast inputs can be used either as regular inputs or as fast inputs for counting or event functions.

(3) The fast transistor outputs can be used as regular transistor outputs, for PLS, PWM, PTO or FREQGEN functions, or reflex outputs for HSC.

Delivery Content

The following figure presents the content of the delivery for a TM221M Logic Controller:

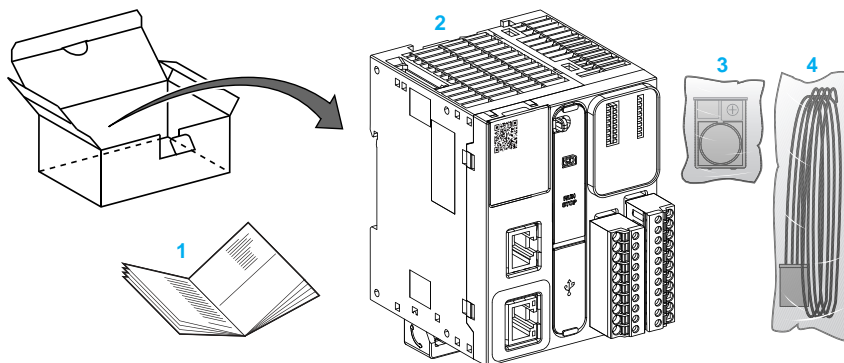

1 TM221M Logic Controller Instruction Sheet

2 TM221M Logic Controller

3 Battery holder with lithium coin battery, type Panasonic BR2032 or Murata CR2032X.

4 Analog cable

Maximum Hardware Configuration

Introduction

The M221 Logic Controller is a control system that offers an all-in-one solution with optimized configurations and an expandable architecture.

Local and Remote Configuration Principle

The following figure defines the local and remote configurations:

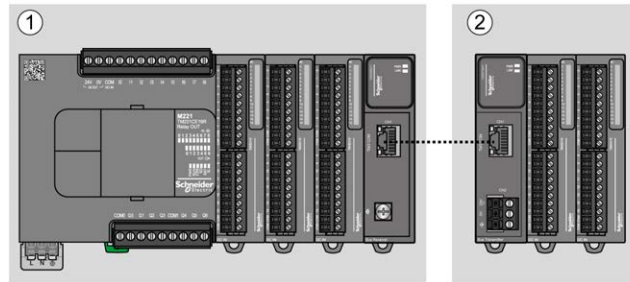

- (1) Local configuration
- (2) Remote configuration

M221 Logic Controller Local Configuration Architecture

Optimized local configuration and flexibility are provided by the association of:

- M221 Logic Controller
- TM3 expansion modules
- TM2 expansion modules

Application requirements determine the architecture of your M221 Logic Controller configuration.

The following figure represents the components of a local configuration:

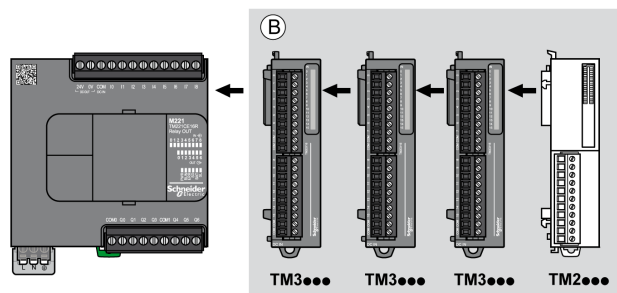

(B) Expansion modules (see maximum number of modules)

NOTE: You cannot mount a TM2 module before any TM3 module as indicated in the following figure:

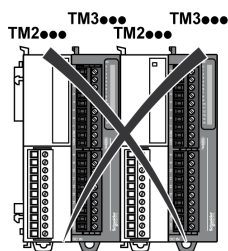

M221 Logic Controller Remote Configuration Architecture

Optimized remote configuration and flexibility are provided by the association of:

- M221 Logic Controller
- TM3 expansion modules
- TM3 transmitter and receiver modules

Application requirements determine the architecture of your M221 Logic Controller configuration.

NOTE: You cannot use TM2 modules in configurations that include the TM3 transmitter and receiver modules.

The following figure represents the components of a remote configuration:

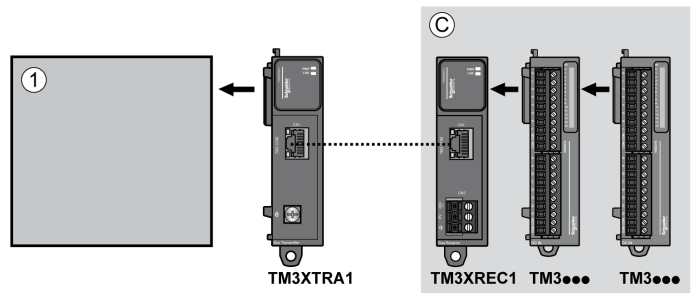

(1) Logic controller and modules

(C) Expansion modules (7 maximum)

M221 Logic Controller Distributed Configuration Architecture

Optimized remote configuration and flexibility are provided by the association of:

- M221 Logic Controller
- TM3 bus couplers

This figure shows the components of a distributed architecture:

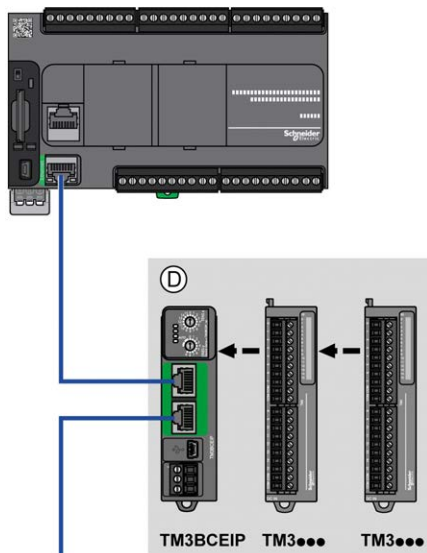

(D) TM3 distributed modules

Maximum Number of Modules

The following table shows the maximum configuration supported:

References	Maximum	Type of Configuration
TM221C**** TM221M*****	7 TM3 / TM2 expansion modules	Local
TM3XREC1	7 TM3 expansion modules	Remote
TM3BCEIP TM3BCSL	7 TM3 / TM2 expansion modules without transmitter and receiver 14 TM3 expansion modules with transmitter and receiver	Distributed
<p>NOTE: TM3 transmitter and receiver modules are not included in a count of the maximum number of expansion modules.</p>		

NOTE: The configuration with its TM3 and TM2 expansion modules is validated by EcoStruxure Machine Expert - Basic software in the **Configuration** window taking into account the total power consumption of the installed modules. The maximum number of supported modules may be reduced due to power consumption. For more information, refer to the Modicon TM3 catalog, or verify your configuration on EcoStruxure Machine Expert - Basic.

NOTE: In some environments, the maximum configuration populated by high consumption modules, coupled with the maximum distance allowable between the TM3 transmitter and receiver modules, may present bus communication issues although the EcoStruxure Machine Expert - Basic software allows for the configuration. In such a case you will need to analyze the consumption of the modules chosen for your configuration, as well as the minimum cable distance required by your application, and possibly seek to optimize your choices.

Current Supplied to the I/O Bus

The following table shows the maximum current supplied by the controllers to the I/O Bus:

Reference	IO Bus 5 Vdc	IO Bus 24 Vdc
TM221C16R TM221CE16R	325 mA	120 mA
TM221C16T TM221CE16T	325 mA	148 mA
TM221C16U TM221CE16U	325 mA	148 mA
TM221C24R TM221CE24R	520 mA	160 mA
TM221C24T TM221CE24T	520 mA	200 mA
TM221C24U TM221CE24U	520 mA	200 mA
TM221C40R TM221CE40R	520 mA	240 mA
TM221C40T TM221CE40T	520 mA	304 mA
TM221C40U TM221CE40U	520 mA	304 mA
TM221M16R• TM221ME16R•	520 mA	460 mA
TM221M16T• TM221ME16T•	520 mA	492 mA
TM221M32TK TM221ME32TK	520 mA	484 mA

NOTE: Expansion modules consume current from the 5 Vdc and 24 Vdc supplied to the I/O Bus. Therefore, the current delivered by the logic controller to the I/O Bus defines the maximum number of expansion modules that can be connected to the I/O Bus (validated by EcoStruxure Machine Expert - Basic software in the **Configuration** window).

TM2 Expansion Modules

Overview

You can expand the number of I/Os of your M221 Logic Controller by adding TM2 I/O expansion modules.

The following types of electronic modules are supported:

- TM2 digital I/O expansion modules
- TM2 analog I/O expansion modules

For more information, refer to the following documents:

- TM2 Digital I/O Expansion Modules Hardware Guide
- TM2 Analog I/O Expansion Modules Hardware Guide

NOTE: TM2 modules can only be used in the local configuration, and only if there is no TM3 transmitter and receiver modules present in the configuration.

NOTE: It is prohibited to mount a TM2 module before any TM3 module. The TM2 modules must be mounted and configured at the end of the local configuration.

TM2 Digital Input Expansion Modules

The following table shows the compatible TM2 digital input expansion modules with the corresponding channel type, nominal voltage/current, and terminal type:

Reference	Channels	Channel Type	Voltage Current	Terminal Type
TM2DAI8DT	8	Regular inputs	120 Vac 7.5 mA	Removable screw terminal block
TM2DDI8DT	8	Regular inputs	24 Vdc 7 mA	Removable screw terminal block
TM2DDI16DT	16	Regular inputs	24 Vdc 7 mA	Removable screw terminal block
TM2DDI16DK	16	Regular inputs	24 Vdc 5 mA	HE10 (MIL 20) connector
TM2DDI32DK	32	Regular inputs	24 Vdc 5 mA	HE10 (MIL 20) connector

TM2 Digital Output Expansion Modules

The following table shows the compatible TM2 digital output expansion modules with the corresponding channel type, nominal voltage/current, and terminal type:

Reference	Channels	Channel type	Voltage Current	Terminal type
TM2DRA8RT	8	Relay outputs	30 Vdc / 240 Vac 2 A max	Removable screw terminal block
TM2DRA16RT	16	Relay outputs	30 Vdc / 240 Vac 2 A max	Removable screw terminal block
TM2DDO8UT	8	Regular transistor outputs (sink)	24 Vdc 0.3 A max per output	Removable screw terminal block
TM2DDO8TT	8	Regular transistor outputs (source)	24 Vdc 0.5 A max per output	Removable screw terminal block
TM2DDO16UK	16	Regular transistor outputs (sink)	24 Vdc 0.1 A max per output	HE10 (MIL 20) connector
TM2DDO16TK	16	Regular transistor outputs (source)	24 Vdc 0.4 A max per output	HE10 (MIL 20) connector
TM2DDO32UK	32	Regular transistor outputs (sink)	24 Vdc 0.1 A max per output	HE10 (MIL 20) connector
TM2DDO32TK	32	Regular transistor outputs (source)	24 Vdc 0.4 A max per output	HE10 (MIL 20) connector

TM2 Digital Mixed Input/Output Expansion Modules

The following table shows the compatible TM2 digital mixed I/O expansion modules with the corresponding channel type, nominal voltage/current, and terminal type:

Reference	Channels	Channel type	Voltage Current	Terminal type
TM2DMM8DRT	4	Regular inputs	24 Vdc 7 mA	Removable screw terminal block
	4	Relay outputs	24 Vdc / 240 Vac 7 A maximum per common line / 2 A maximum per output	
TM2DMM24DRF	16	Regular inputs	24 Vdc 7 mA	Non-removable spring terminal block
	8	Relay outputs	24 Vdc / 240 Vac 7 A maximum per common line / 2 A maximum per output	

TM2 Analog Input Expansion Modules

The following table shows the compatible TM2 analog input expansion modules with the corresponding channel type, nominal voltage/current, and terminal type:

Reference	Channels	Channel type	Voltage Current	Terminal Type
TM2AMI2HT	2	High-level inputs	0...10 Vdc 4...20 mA	Removable screw terminal block
TM2AMI2LT	2	Low-level inputs	Thermocouple type J, K, T	Removable screw terminal block
TM2AMI4LT	4	Analog inputs	0...10 Vdc 0...20 mA PT100/1000 Ni100/1000	Removable screw terminal block
TM2AMI8HT	8	Analog inputs	0...20 mA 0...10 Vdc	Removable screw terminal block
TM2ARI8HT	8	Analog inputs	NTC / PTC	Removable screw terminal block
TM2ARI8LRJ	8	Analog inputs	PT100/1000	RJ11 connector
TM2ARI8LT	8	Analog inputs	PT100/1000	Removable screw terminal block

TM2 Analog Output Expansion Modules

The following table shows the compatible TM2 analog output expansion modules with the corresponding channel type, nominal voltage/current, and terminal type:

Reference	Channels	Channel type	Voltage Current	Terminal Type
TM2AMO1HT	1	Analog outputs	0...10 Vdc 4...20 mA	Removable screw terminal block
TM2AVO2HT	2	Analog outputs	+/- 10 Vdc	Removable screw terminal block

TM2 Analog Mixed Input/Output Expansion Modules

The following table shows the compatible TM2 analog mixed I/O expansion modules with the corresponding channel type, nominal voltage/current, and terminal type:

Reference	Channels	Channel type	Voltage Current	Terminal Type
TM2AMM3HT	2	Analog inputs	0...10 Vdc 4...20 mA	Removable screw terminal block
	1	Analog outputs	0...10 Vdc 4...20 mA	
TM2AMM6HT	4	Analog inputs	0...10 Vdc 4...20 mA	Removable screw terminal block
	2	Analog outputs	0...10 Vdc 4...20 mA	
TM2ALM3LT	2	Low-level inputs	Thermo J, K, T, PT100	Removable screw terminal block
	1	Analog outputs	0...10 Vdc 4...20 mA	

TM3 Expansion Modules

Introduction

The range of TM3 expansion modules includes:

- Digital modules, classified as follows:
 - Input modules, page 32
 - Output modules, page 33
 - Mixed input/output modules, page 34
- Analog modules, classified as follows:
 - Input modules, page 35
 - Output modules, page 36
 - Mixed input/output modules, page 37
- Expert modules, page 37
- Safety modules, page 38
- Transmitter and Receiver modules, page 39

For more information, refer to the following documents:

- TM3 Digital I/O Modules Hardware Guide
- TM3 Analog I/O Modules Hardware Guide
- TM3 Expert I/O Modules Hardware Guide
- TM3 Safety Modules Hardware Guide
- TM3 Transmitter and Receiver Modules Hardware Guide

TM3 Digital Input Modules

The following table shows the TM3 digital input expansion modules, with corresponding channel type, nominal voltage/current, and terminal type:

Reference	Channels	Channel Type	Voltage Current	Terminal Type / Pitch
TM3DI8A	8	Regular inputs	120 Vac 7.5 mA	Removable screw terminal block / 5.08 mm
TM3DI8	8	Regular inputs	24 Vdc 7 mA	Removable screw terminal block / 5.08 mm
TM3DI8G	8	Regular inputs	24 Vdc 7 mA	Removable spring terminal block / 5.08 mm
TM3DI16	16	Regular inputs	24 Vdc 7 mA	Removable screw terminal blocks / 3.81 mm
TM3DI16G	16	Regular inputs	24 Vdc 7 mA	Removable spring terminal blocks / 3.81 mm
TM3DI16K	16	Regular inputs	24 Vdc 5 mA	HE10 (MIL 20) connector
TM3DI32K	32	Regular inputs	24 Vdc 5 mA	HE10 (MIL 20) connector

TM3 Digital Output Modules

The following table shows the TM3 digital output expansion modules, with corresponding channel type, nominal voltage/current, and terminal type:

Reference	Channels	Channel Type	Voltage Current	Terminal Type / Pitch
TM3DQ8R	8	Relay outputs	24 Vdc / 240 Vac 7 A maximum per common line / 2 A maximum per output	Removable screw terminal block / 5.08 mm
TM3DQ8RG	8	Relay outputs	24 Vdc / 240 Vac 7 A maximum per common line / 2 A maximum per output	Removable spring terminal block / 5.08 mm
TM3DQ8T	8	Regular transistor outputs (source)	24 Vdc 4 A maximum per common line/0.5 A maximum per output	Removable screw terminal block / 5.08 mm
TM3DQ8TG	8	Regular transistor outputs (source)	24 Vdc 4 A maximum per common line/0.5 A maximum per output	Removable spring terminal block / 5.08 mm
TM3DQ8U	8	Regular transistor outputs (sink)	24 Vdc 4 A maximum per common line/0.5 A maximum per output	Removable screw terminal block / 5.08 mm
TM3DQ8UG	8	Regular transistor outputs (sink)	24 Vdc 4 A maximum per common line/0.5 A maximum per output	Removable spring terminal block / 5.08 mm
TM3DQ16R	16	Relay outputs	24 Vdc / 240 Vac 8 A maximum per common line / 2 A maximum per output	Removable screw terminal blocks / 3.81 mm
TM3DQ16RG	16	Relay outputs	24 Vdc / 240 Vac 8 A maximum per common line / 2 A maximum per output	Removable spring terminal blocks / 3.81 mm
TM3DQ16T	16	Regular transistor outputs (source)	24 Vdc 8 A maximum per common line / 0.5 A maximum per output	Removable screw terminal blocks / 3.81 mm
TM3DQ16TG	16	Regular transistor outputs (source)	24 Vdc 8 A maximum per common line / 0.5 A maximum per output	Removable spring terminal blocks / 3.81 mm
TM3DQ16U	16	Regular transistor outputs (sink)	24 Vdc 8 A maximum per common line / 0.5 A maximum per output	Removable screw terminal blocks / 3.81 mm
TM3DQ16UG	16	Regular transistor outputs (sink)	24 Vdc 8 A maximum per common line / 0.5 A maximum per output	Removable spring terminal blocks / 3.81 mm

Reference	Channels	Channel Type	Voltage Current	Terminal Type / Pitch
TM3DQ16TK	16	Regular transistor outputs (source)	24 Vdc 2 A maximum per common line / 0.1 A maximum per output	HE10 (MIL 20) connector
TM3DQ16UK	16	Regular transistor outputs (sink)	24 Vdc 2 A maximum per common line / 0.1 A maximum per output	HE10 (MIL 20) connector
TM3DQ32TK	32	Regular transistor outputs (source)	24 Vdc 2 A maximum per common line / 0.1 A maximum per output	HE10 (MIL 20) connectors
TM3DQ32UK	32	Regular transistor outputs (sink)	24 Vdc 2 A maximum per common line / 0.1 A maximum per output	HE10 (MIL 20) connectors

TM3 Digital Mixed Input/Output Modules

This following table shows the TM3 mixed I/O modules, with corresponding channel type, nominal voltage/current, and terminal type:

Reference	Channels	Channel Type	Voltage Current	Terminal Type / Pitch
TM3DM8R	4	Regular inputs	24 Vdc 7 mA	Removable screw terminal block / 5.08 mm
	4	Relay outputs	24 Vdc / 240 Vac 7 A maximum per common line / 2 A maximum per output	
TM3DM8RG	4	Regular inputs	24 Vdc 7 mA	Removable spring terminal block / 5.08 mm
	4	Relay outputs	24 Vdc / 240 Vac 7 A maximum per common line / 2 A maximum per output	
TM3DM24R	16	Regular inputs	24 Vdc 7 mA	Removable screw terminal blocks / 3.81 mm
	8	Relay outputs	24 Vdc / 240 Vac 7 A maximum per common line / 2 A maximum per output	
TM3DM24RG	16	Regular inputs	24 Vdc 7 mA	Removable spring terminal blocks / 3.81 mm
	8	Relay outputs	24 Vdc / 240 Vac 7 A maximum per common line / 2 A maximum per output	

TM3 Analog Input Modules

The following table shows the TM3 analog input expansion modules, with corresponding resolution, channel type, nominal voltage/current, and terminal type:

Reference	Resolution	Channels	Channel Type	Mode	Terminal Type / Pitch
TM3AI2H	16 bit, or 15 bit + sign	2	inputs	0...10 Vdc -10...+10 Vdc 0...20 mA 4...20 mA	Removable screw terminal block / 5.08 mm
TM3AI2HG	16 bit, or 15 bit + sign	2	inputs	0...10 Vdc -10...+10 Vdc 0...20 mA 4...20 mA	Removable spring terminal block / 5.08 mm
TM3AI4	12 bit, or 11 bit + sign	4	inputs	0...10 Vdc -10...+10 Vdc 0...20 mA 4...20 mA	Removable screw terminal block / 3.81 mm
TM3AI4G	12 bit, or 11 bit + sign	4	inputs	0...10 Vdc -10...+10 Vdc 0...20 mA 4...20 mA	Removable spring terminal blocks / 3.81 mm
TM3AI8	12 bit, or 11 bit + sign	8	inputs	0...10 Vdc -10...+10 Vdc 0...20 mA 4...20 mA 0...20 mA extended 4...20 mA extended	Removable screw terminal block / 3.81 mm
TM3AI8G	12 bit, or 11 bit + sign	8	inputs	0...10 Vdc -10...+10 Vdc 0...20 mA 4...20 mA 0...20 mA extended 4...20 mA extended	Removable spring terminal blocks / 3.81 mm
TM3TI4	16 bit, or 15 bit + sign	4	inputs	0...10 Vdc -10...+10 Vdc 0...20 mA 4...20 mA Thermocouple PT100/1000 NI100/1000	Removable screw terminal block / 3.81 mm

Reference	Resolution	Channels	Channel Type	Mode	Terminal Type / Pitch
TM3TI4G	16 bit, or 15 bit + sign	4	inputs	0...10 Vdc -10...+10 Vdc 0...20 mA 4...20 mA Thermocouple PT100/1000 NI100/1000	Removable spring terminal blocks / 3.81 mm
TM3TI4D	16 bit, or 15 bit + sign	4	inputs	Thermocouple	Removable screw terminal block / 3.81 mm
TM3TI4DG	16 bit, or 15 bit + sign	4	inputs	Thermocouple	Removable spring terminal blocks / 3.81 mm
TM3TI8T	16 bit, or 15 bit + sign	8	inputs	Thermocouple NTC/PTC Ohmmeter	Removable screw terminal block / 3.81 mm
TM3TI8TG	16 bit, or 15 bit + sign	8	inputs	Thermocouple NTC/PTC Ohmmeter	Removable spring terminal blocks / 3.81 mm

TM3 Analog Output Modules

The following table shows the TM3 analog output modules, with corresponding resolution, channel type, nominal voltage/current, and terminal type:

Reference	Resolution	Channels	Channel Type	Mode	Terminal Type / Pitch
TM3AQ2	12 bit, or 11 bit + sign	2	outputs	0...10 Vdc -10...+10 Vdc 0...20 mA 4...20 mA	Removable screw terminal block / 5.08 mm
TM3AQ2G	12 bit, or 11 bit + sign	2	outputs	0...10 Vdc -10...+10 Vdc 0...20 mA 4...20 mA	Removable spring terminal block / 5.08 mm
TM3AQ4	12 bit, or 11 bit + sign	4	outputs	0...10 Vdc -10...+10 Vdc 0...20 mA 4...20 mA	Removable screw terminal block / 5.08 mm
TM3AQ4G	12 bit, or 11 bit + sign	4	outputs	0...10 Vdc -10...+10 Vdc 0...20 mA 4...20 mA	Removable spring terminal block / 5.08 mm

TM3 Analog Mixed Input/Output Modules

This following table shows the TM3 analog mixed I/O modules, with corresponding resolution, channel type, nominal voltage/current, and terminal type:

Reference	Resolution	Channels	Channel Type	Mode	Terminal Type / Pitch
TM3AM6	12 bit, or 11 bit + sign	4	inputs	0...10 Vdc	Removable screw terminal block / 3.81 mm
		2	outputs	-10...+10 Vdc 0...20 mA 4...20 mA	
TM3AM6G	12 bit, or 11 bit + sign	4	inputs	0...10 Vdc	Removable spring terminal block / 3.81 mm
		2	outputs	-10...+10 Vdc 0...20 mA 4...20 mA	
TM3TM3	16 bit, or 15 bit + sign	2	inputs	0...10 Vdc -10...+10 Vdc 0...20 mA 4...20 mA Thermocouple PT100/1000 NI100/1000	Removable screw terminal block / 5.08 mm
	12 bit, or 11 bit + sign	1	outputs	0...10 Vdc -10...+10 Vdc 0...20 mA 4...20 mA	
TM3TM3G	16 bit, or 15 bit + sign	2	inputs	0...10 Vdc -10...+10 Vdc 0...20 mA 4...20 mA Thermocouple PT100/1000 NI100/1000	Removable spring terminal block / 5.08 mm
	12 bit, or 11 bit + sign	1	outputs	0...10 Vdc -10...+10 Vdc 0...20 mA 4...20 mA	

TM3 Expert Module

The following table shows the TM3 expert expansion module, with corresponding terminal types:

Reference	Description	Terminal Type / Pitch
TM3XTYS4	TeSys module	4 front connectors RJ-45 1 removable power supply connector / 5.08 mm

TM3 Safety Modules

This table contains the TM3 safety modules (see Modicon TM3, Safety Modules, Hardware Guide), with the corresponding channel type, nominal voltage/current, and terminal type:

Reference	Function Category	Channels	Channel type	Voltage Current	Terminal type
TM3SAC5R	1 function, up to category 3	1 or 2 ⁽¹⁾	Safety input	24 Vdc	3.81 mm (0.15 in.) and 5.08 mm (0.20 in.), removable screw terminal block
		Start ⁽²⁾	Input	100 mA maximum	
		3 in parallel	Relay outputs Normally open	24 Vdc / 230 Vac 6 A maximum per output	
TM3SAC5RG	1 function, up to category 3	1 or 2 ⁽¹⁾	Safety input	24 Vdc	3.81 mm (0.15 in.) and 5.08 mm (0.20 in.), removable spring terminal block
		Start ⁽²⁾	Input	100 mA maximum	
		3 in parallel	Relay outputs Normally open	24 Vdc / 230 Vac 6 A maximum per output	
TM3SAF5R	1 function, up to category 4	2 ⁽¹⁾	Safety inputs	24 Vdc	3.81 mm (0.15 in.) and 5.08 mm (0.20 in.), removable screw terminal block
		Start	Input	100 mA maximum	
		3 in parallel	Relay outputs Normally open	24 Vdc / 230 Vac 6 A maximum per output	
TM3SAF5RG	1 function, up to category 4	2 ⁽¹⁾	Safety inputs	24 Vdc	3.81 mm (0.15 in.) and 5.08 mm (0.20 in.), removable spring terminal block
		Start	Input	100 mA maximum	
		3 in parallel	Relay outputs Normally open	24 Vdc / 230 Vac 6 A maximum per output	
TM3SAFL5R	2 functions, up to category 3	2 ⁽¹⁾	Safety inputs	24 Vdc	3.81 mm (0.15 in.) and 5.08 mm (0.20 in.), removable screw terminal block
		Start	Input	100 mA maximum	
		3 in parallel	Relay outputs Normally open	24 Vdc / 230 Vac 6 A maximum per output	
TM3SAFL5RG	2 functions, up to category 3	2 ⁽¹⁾	Safety inputs	24 Vdc	3.81 mm (0.15 in.) and 5.08 mm (0.20 in.), removable spring terminal block
		Start	Input	100 mA maximum	
		3 in parallel	Relay outputs Normally open	24 Vdc / 230 Vac 6 A maximum per output	
TM3SAK6R	3 functions, up to category 4	1 or 2 ⁽¹⁾	Safety inputs	24 Vdc	3.81 mm (0.15 in.) and 5.08 mm (0.20 in.), removable screw terminal block
		Start	Input	100 mA maximum	
		3 in parallel	Relay outputs Normally open	24 Vdc / 230 Vac 6 A maximum per output	
TM3SAK6RG	3 functions, up to category 4	1 or 2 ⁽¹⁾	Safety inputs	24 Vdc	3.81 mm (0.15 in.) and 5.08 mm (0.20 in.), removable spring terminal block
		Start	Input	100 mA maximum	
		3 in parallel	Relay outputs Normally open	24 Vdc / 230 Vac 6 A maximum per output	
<p>(1) Depending on external wiring</p> <p>(2) Non-monitored start</p>					

TM3 Transmitter and Receiver Modules

The following table shows the TM3 transmitter and receiver expansion modules:

Reference	Description	Terminal Type / Pitch
TM3XTRA1	Data transmitter module for remote I/O	1 front connector RJ-45 1 screw for functional ground connection
TM3XREC1	Data receiver module for remote I/O	1 front connector RJ-45 Power supply connector / 5.08 mm

TM3 Bus Couplers

Introduction

The TM3 bus coupler is a device designed to manage fieldbus communication when using TM2 and TM3 expansion modules in a distributed architecture.

For more information, refer to the Modicon TM3 Bus Coupler Hardware Guide.

Modicon TM3 Bus Couplers

The following table shows the TM3 bus couplers, their ports, communication and terminal types:

Reference	Port	Communication type	Terminal type
TM3BCEIP	2 isolated switched Ethernet ports	Modbus TCP	RJ45
	1 USB port	USB 2.0	USB mini-B
TM3BCSL	2 isolated RS-485 ports (daisy-chained)	Serial Line Modbus	RJ45
	1 USB port	USB 2.0	USB mini-B

TMC2 Cartridges

Overview

You can expand the number of I/Os or communication options of your Modicon TM221C Logic Controller by adding TMC2 cartridges.

For more information, refer to the TMC2 Cartridges Hardware Guide.

TMC2 Standard Cartridges

The following table presents the general-purpose TMC2 cartridges with the corresponding channel type, voltage/current range, and terminal type:

Reference	Channels	Channel Type	Voltage Current	Terminal Type
TMC2AI2	2	Analog inputs (voltage or current)	0...10 Vdc 0...20 mA or 4...20 mA	3.81 mm (0.15 in.) pitch, non-removable screw terminal block
TMC2TI2	2	Analog temperature inputs	Thermocouple type K, J, R, S, B, E, T, N, C 3 wires RTD type Pt100, Pt1000, Ni100, Ni1000	3.81 mm (0.15 in.) pitch, non-removable screw terminal block
TMC2AQ2V	2	Analog voltage outputs	0...10 Vdc	3.81 mm (0.15 in.) pitch, non-removable screw terminal block
TMC2AQ2C	2	Analog current outputs	4...20 mA	3.81 mm (0.15 in.) pitch, non-removable screw terminal block
TMC2SL1 ⁽¹⁾	1	Serial line	RS232 or RS485	3.81 mm (0.15 in.) pitch, non-removable screw terminal block
(1) Only one serial line cartridge (TMC2SL1, TMC2CONV01) may be added to a logic controller.				

TMC2 Application Cartridges

The following table presents the applicative TMC2 cartridges with the corresponding channel type, voltage/current range, and terminal type:

Reference	Channels	Channel Type	Voltage Current	Terminal Type
TMC2HOIS01	2	Analog inputs (voltage or current)	0...10 Vdc 0...20 mA or 4...20 mA	3.81 mm (0.15 in.) pitch, non-removable screw terminal block
TMC2PACK01	2	Analog inputs (voltage or current)	0...10 Vdc 0...20 mA or 4...20 mA	3.81 mm (0.15 in.) pitch, non-removable screw terminal block
TMC2CONV01 ⁽¹⁾	1	Serial line	RS232 or RS485	3.81 mm (0.15 in.) pitch, non-removable screw terminal block
(1) Only one serial line cartridge (TMC2SL1, TMC2CONV01) may be added to a logic controller.				

Accessories

Overview

This section describes the accessories, cables, and Telefast.

Accessories

Reference	Description	Use	Quantity
TMASD1	SD Card, page 55	Use to update the controller firmware, store data (data logging), initialize a controller with a new application or clone a controller.	1
TMAT2MSET	Set of 8 removable screw terminal blocks: <ul style="list-style-type: none"> 4 x Removable screw terminal blocks (pitch 3.81 mm) with 11 terminals for inputs/outputs 4 x Removable screw terminal blocks (pitch 3.81 mm) with 10 terminals for inputs/outputs 	Connects TM221M Logic Controller embedded I/Os.	
TMAT2MSETG	Set of 8 removable spring terminal blocks: <ul style="list-style-type: none"> 4 x Removable spring terminal blocks (pitch 3.81 mm) with 11 terminals for inputs/outputs 4 x Removable spring terminal blocks (pitch 3.81 mm) with 10 terminals for inputs/outputs 		
TMAT2PSET	Set of 5 removable screw terminal blocks	Connects 24 Vdc power supply.	
TMAT2CSET16G	Set of 2 removable spring terminal blocks: <ul style="list-style-type: none"> 1 x Removable spring terminal block (pitch 5.08 mm) with 9 terminals for inputs/outputs 1 x Removable spring terminal block (pitch 5.08 mm) with 12 terminals for inputs/outputs 	Connects TM221C Logic Controller embedded I/Os.	
TMAT2CSET24G	Set of 3 removable spring terminal blocks: <ul style="list-style-type: none"> 1 x Removable spring terminal block (pitch 5.08 mm) with 8 terminals for inputs/outputs 1 x Removable spring terminal block (pitch 5.08 mm) with 9 terminals for inputs/outputs 1 x Removable spring terminal block (pitch 5.08 mm) with 13 terminals for inputs/outputs 		
TMAT2CSET40G	Set of 5 removable spring terminal blocks: <ul style="list-style-type: none"> 3 x Removable spring terminal block (pitch 5.08 mm) with 9 terminals for inputs/outputs 2 x Removable spring terminal block (pitch 5.08 mm) with 10 terminals for inputs/outputs 		
NSYTRAAB35	End brackets		
TMAM2	Mounting kit	Mounts the controller and I/O modules directly to a flat, vertical panel.	
TM200RSRCEMC	Shielding take-up clip	Mounts and connects the ground to the cable shielding.	25-pack

For top hat section rails (DIN rails), refer to Top Hat Section Rail (DIN rail), page 69.

Cables

Reference	Description	Details	Length
TCSXCNAMUM3P	Terminal port/USB port cordset	From the USB mini-B port on the M221 Logic Controller to USB port on the PC terminal.	3 m (10 ft)
BMXXCAUSBH018		From the USB mini-B port on the M221 Logic Controller to USB port on the PC terminal. NOTE: Grounded and shielded, this USB cable is suitable for long duration connections.	1.8 m (5.9 ft)
TMACBL1	Analog cables	Cable equipped with a connector	1 m (3.28 ft)
TCSMCN3M4F3C2	RS-232 serial link cordset	For DTE terminal (printer) 1 RJ45 connector and 1 SUB-D 9 connector	3 m (9.84 ft)
TCSMCN3M4M3S2		For DCE terminal (modem, converter) 1 RJ45 connector and 1 SUB-D 9 connector	
TWDFCW••K	Digital I/O cables with free wires for 20-pin connectors	Cable equipped at one end with an HE10/MIL20 connector (AWG 22 / 0.34 mm ²).	3 or 5 m (9.84 or 16.4 ft)

TWDFCW••K Cable Description

The following table provides specifications for the TWDFCW••K cable with free wires for 20-pin connectors (HE10/MIL20):

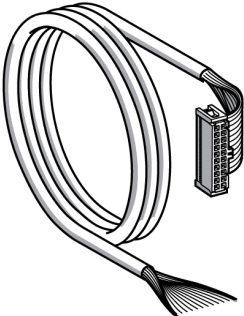
Cable illustration	Pin Connector	Wire Color
	1	White
	2	Brown
	3	Green
	4	Yellow
	5	Grey
	6	Pink
	7	Blue
	8	Red
	9	Black
	10	Violet
	11	Grey and pink
	12	Red and blue
	13	White and green
	14	Brown and green
	15	White and yellow
	16	Yellow and brown
	17	White and grey
	18	Grey and brown
	19	White and pink
	20	Pink and brown

Telefast Pre-Wiring Sub-Bases

The following illustration shows the Telefast system:

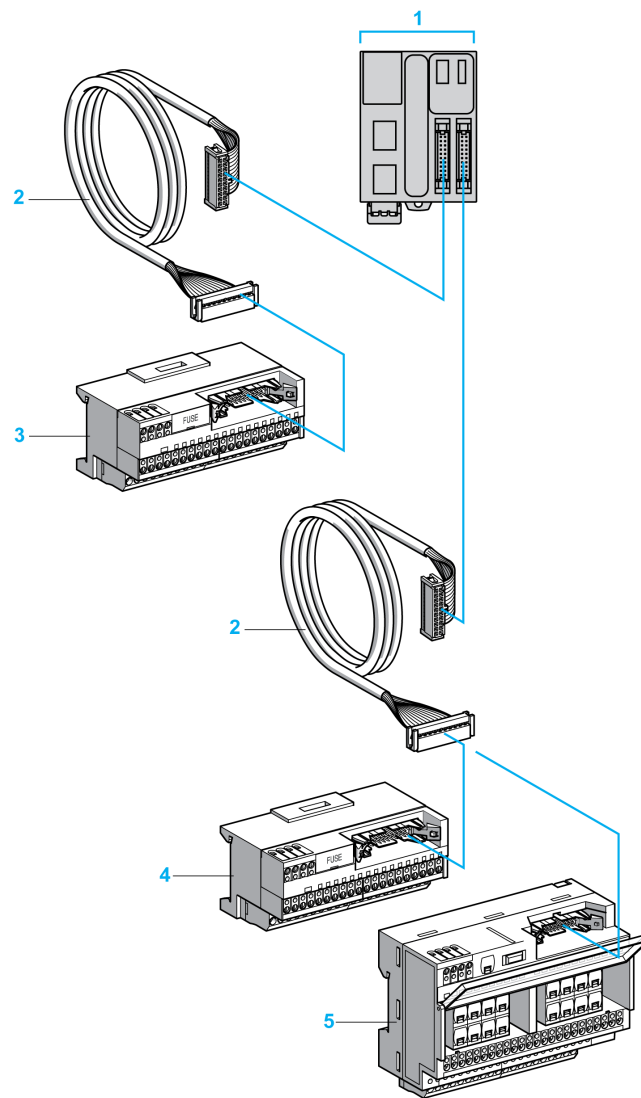

1 TM221M32TK / TM221ME32TK

2 Cable equipped with a 20-way HE10/MIL20 connector at each end.

3 16 channel sub-base for input extension modules.

4 16 channel sub-base for output extension modules.

5 16 channel sub-base for output extension modules.

Refer to TM221M Logic Controller Instruction Sheet.

M221 Features

What's in This Chapter

Real Time Clock (RTC)	44
Input Management	48
Output Management.....	50
Run/Stop	53
SD Card	55

Overview

This chapter describes the Modicon M221 Logic Controller features.

Real Time Clock (RTC)

Overview

The M221 Logic Controller includes an RTC to provide system date and time information, and to support related functions requiring a real-time clock. To continue keeping time when power is off, a non-rechargeable battery is required (see reference below). A battery LED on the front panel of the controller indicates if the battery is depleted or absent.

This table shows how RTC drift is managed:

RTC Characteristics	Description
RTC drift	Less than 30 seconds per month at 25 °C (77 °F)

Battery

The controller has one backup battery.

In the event of a power interruption, the backup battery maintains user data and the RTC for the controller.

This table shows the characteristics of the battery:

Characteristics	Description
Use	In the event of a transient power outage, the battery powers the RTC and user data.
Backup life	At least 1 year at 25 °C maximum (77 °F). At higher temperatures, the time is reduced.
Battery monitoring	Yes
Replaceable	Yes
Battery life	4 years at 25 °C maximum (77 °F). At higher temperatures, the time is reduced.
Controller battery	Lithium coin, Panasonic BR2032 or Murata CR2032X.

Installing and Replacing the Battery

While lithium batteries are preferred due to their slow discharge and long life, they can present hazards to personnel, equipment and the environment and must be handled properly.

⚠ DANGER

EXPLOSION, FIRE, OR CHEMICAL BURNS

- Replace with identical battery type.
- Follow all the instructions of the battery manufacturer.
- Remove all replaceable batteries before discarding unit.
- Recycle or properly dispose of used batteries.
- Protect battery from any potential short-circuit.
- Do not recharge, disassemble, heat above 100 °C (212 °F), or incinerate.
- Use your hands or insulated tools to remove or replace the battery.
- Maintain proper polarity when inserting and connecting a new battery.

Failure to follow these instructions will result in death or serious injury.

NOTE: Replacement of the battery will lead to the loss of RTC and data not saved in the non-volatile memory.

Refer to Persistent Variables (see M221 Logic Controller Configuration - Programming Guide).

To install or replace the battery, follow these steps:

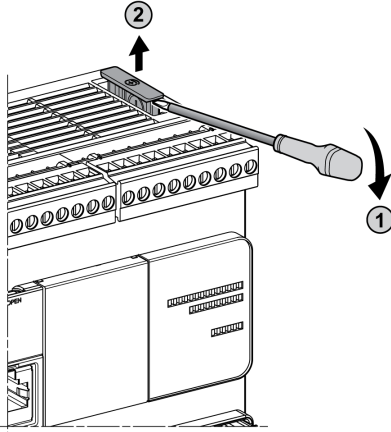
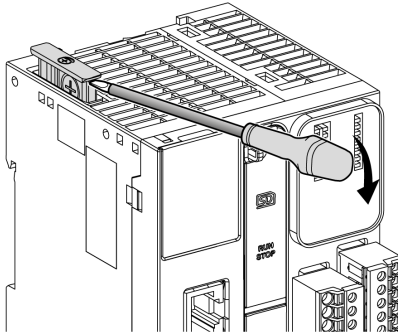
Step	Action
1	Remove power from your controller.
2	Use an insulated screw-driver to pull out the battery holder from the TM221C Logic Controller.  <p>Use an insulated screw-driver to pull out the battery holder from the TM221M Logic Controller. </p>

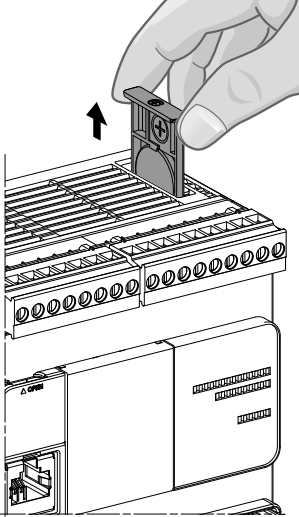
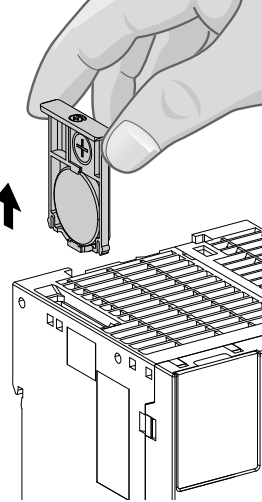
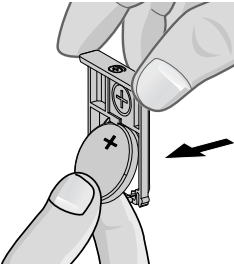
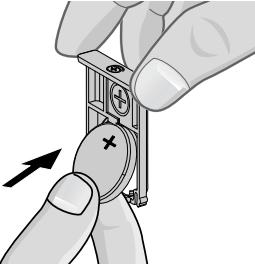
Step	Action
3	<p data-bbox="619 174 1177 206">Slide out the battery holder of the TM221C Logic Controller.</p>  <p data-bbox="619 752 1177 784">Slide out the battery holder of the TM221M Logic Controller.</p> 
4	<p data-bbox="619 1319 1026 1350">Remove the battery from the battery holder.</p> 
5	<p data-bbox="619 1650 1417 1704">Insert the new battery into the battery holder in accordance with the polarity markings on the battery.</p> 

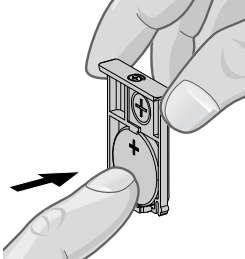
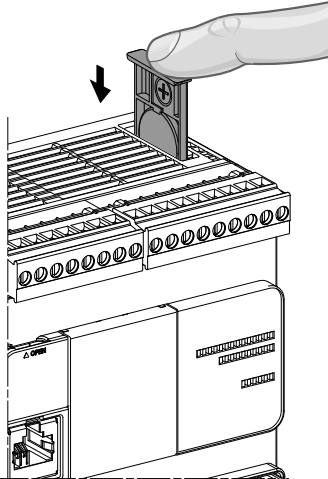
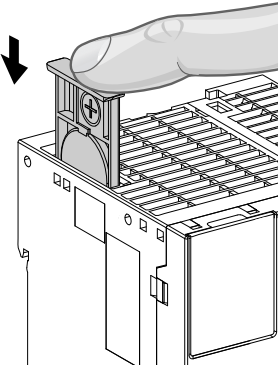
Step	Action
6	Replace the battery holder on the controller and verify that the latch clicks into place. 
7	Slide in the battery holder of the TM221C Logic Controller.  Slide in the battery holder of the TM221M Logic Controller. 
8	Power up your M221 Logic Controller.
9	Set the internal clock. For further details on the internal clock, refer to EcoStruxure Machine Expert - Basic Operating Guide (see EcoStruxure Machine Expert - Basic, Generic Functions Library Guide).

NOTE: Replacement of the battery in the controllers other than with the types specified in this documentation may present a risk of fire or explosion.

⚠ WARNING

IMPROPER BATTERY CAN PROVOKE FIRE OR EXPLOSION

Replace battery only with identical type: Panasonic Type BR2032 or Murata Type CR2032X.

Failure to follow these instructions can result in death, serious injury, or equipment damage.

Input Management

Overview

The M221 Logic Controller features digital inputs, including 4 fast inputs.

The following functions are configurable:

- Filters (depends on the function associated with the input).
- **I0...I15** inputs can be used for the Run/Stop function.
- Four fast inputs can be either latched or used for events (rising edge, falling edge, or both) and thus be linked to an external task.

NOTE: All inputs can be used as regular inputs.

Integrator Filter Principle

The filter is designed to reduce the bouncing effect at the inputs. Setting a filter value helps the controller to ignore sudden changes of input levels caused by induction of electromagnetic interference.

The following timing diagram illustrates the filter effects:

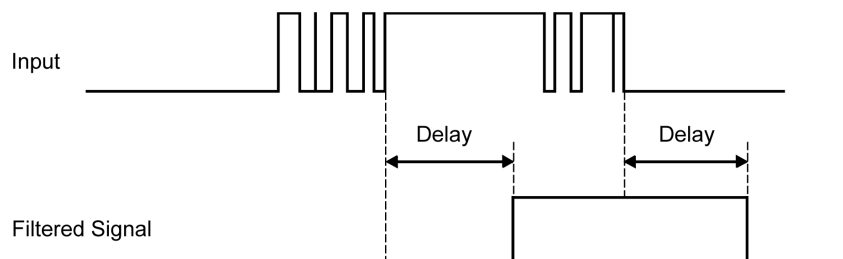

Bounce Filter Availability

The bounce filter can be used on a fast input when:

- Using a latch or event
- HSC is enabled

Latching

Latching is a function that can be assigned to the M221 Logic Controller fast inputs. This function is used to memorize (or latch) any pulse with a duration that is less than the M221 Logic Controller scan time. When a pulse is shorter than one scan, the controller latches the pulse, which is then updated in the next scan. This latching mechanism only recognizes rising edges. Falling edges cannot be latched. Assigning inputs to be latched is done in the **Configuration** tab in EcoStruxure Machine Expert - Basic.

The following timing diagram illustrates the latching effects:

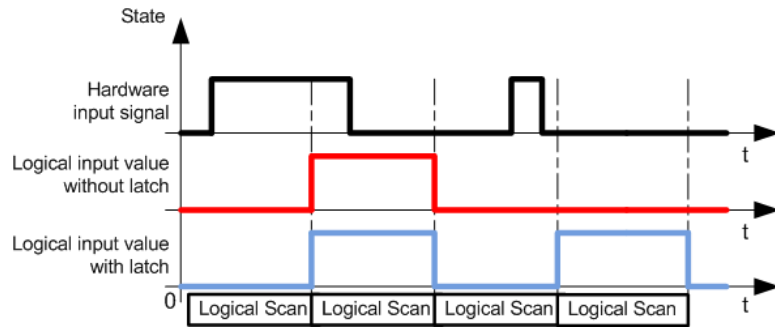

Event

An input configured for Event can be associated with an External Task.

Run/Stop

The Run/Stop function is used to start or stop an application program using an input. In addition to the embedded Run/Stop switch, you can configure one (and only one) input as an additional Run/Stop command.

For more information, refer to the [Run/Stop](#), page 53.

⚠ WARNING

UNINTENDED MACHINE OR PROCESS START-UP

- Verify the state of security of your machine or process environment before applying power to the Run/Stop input.
- Use the Run/Stop input to help prevent the unintentional start-up from a remote location.

Failure to follow these instructions can result in death, serious injury, or equipment damage.

Input Management Functions Availability

Embedded digital inputs can be assigned to functions (Run/Stop, Latch, Event, Fast Counter, HSC, PTO). Inputs not assigned to functions are used as regular inputs. The following table presents the possible assignments of the embedded M221 Logic Controller digital inputs:

Function		Simple Input Function			Advanced Input Function		
		Run/Stop	Latch	Event	Fast Counter	HSC	PTO ⁽³⁾
Fast Input	%I0.0	X	–	–	–	%HSC0	–
	%I0.1	X	–	–	–	%HSC0 or %HSC2 ⁽¹⁾	–
Regular Input	%I0.2	X	X	X	%FC0	Preset for %HSC0	Ref or probe for %PTO0 to %PTO3
	%I0.3	X	X	X	%FC1	Catch for %HSC0	
	%I0.4	X	X	X	%FC2	Catch for %HSC1	
	%I0.5	X	X	X	%FC3	Preset for %HSC1	
Fast Input	%I0.6	X	–	–	–	%HSC1	–
	%I0.7	X	–	–	–	%HSC1 or %HSC3 ⁽²⁾	–
Regular Input (depending on the controller reference)	%I0.8	X	–	–	–	–	Ref or probe for %PTO0 to %PTO3 on TM221C40U and TM221CE40U controllers
	%I0.9	X	–	–	–	–	
	%I0.10	X	–	–	–	–	
	%I0.11	X	–	–	–	–	
	%I0.12	X	–	–	–	–	
	%I0.13	X	–	–	–	–	
	%I0.14	X	–	–	–	–	
	%I0.15	X	–	–	–	–	
	%I0.16	X	–	–	–	–	
	%I0.17	X	–	–	–	–	
	%I0.18	X	–	–	–	–	
	%I0.19	X	–	–	–	–	
	%I0.20	X	–	–	–	–	
	%I0.21	X	–	–	–	–	
%I0.22	X	–	–	–	–		
%I0.23	X	–	–	–	–		

X Yes
– No

(1) %HSC2 is available when %HSC0 is configured as Single Phase or Not Configured.
(2) %HSC3 is available when %HSC1 is configured as Single Phase or Not Configured.
(3) PTO function is available on controller references that contain transistor outputs.

Output Management

Introduction

The M221 Logic Controller features both regular and fast transistor outputs (PLS/PWM/PTO/FREQGEN).

The following output functions are configurable on the transistor outputs:

- Alarm output
- HSC (reflex features on HSC threshold)
- PLS
- PTO
- PWM
- FREQGEN

NOTE: All outputs can be used as regular outputs.

Output Management Availability

The information below refers to regular and fast transistor outputs on the M221 Logic Controller:

Function		Alarm Output	HSC	PLS / PWM / PTO / FREQGEN
Fast Output ⁽¹⁾	%Q0.0	X	–	<ul style="list-style-type: none"> • %PLS0 • %PWM0 • %PTO0 • %FREQGEN0
	%Q0.1	X	–	<ul style="list-style-type: none"> • %PLS1 • %PWM1 • %PTO⁽²⁾ • %FREQGEN1
Regular Output ⁽³⁾ (depending on the controller reference)	%Q0.2	X	Reflex output 0 for %HSC0 or %HSC2	<ul style="list-style-type: none"> • %PTO⁽⁴⁾ • %FREQGEN2
	%Q0.3	X	Reflex output 1 for %HSC0 or %HSC2	<ul style="list-style-type: none"> • %PTO⁽⁵⁾ • %FREQGEN3
	%Q0.4	X	Reflex output 0 for %HSC1 or %HSC3	%PTOx direction
	%Q0.5	X	Reflex output 1 for %HSC1 or %HSC3	%PTOx direction
	%Q0.6	X	–	%PTOx direction
	%Q0.7	X	–	%PTOx direction
	%Q0.8	–	–	%PTOx direction
	%Q0.9	–	–	%PTOx direction
	%Q0.10	–	–	%PTOx direction
	%Q0.11	–	–	%PTOx direction
	%Q0.12	–	–	%PTOx direction
	%Q0.13	–	–	%PTOx direction
	%Q0.14	–	–	%PTOx direction
	%Q0.15	–	–	%PTOx direction

(1) Fast output functions are only available on controller references that contain transistor outputs.

(2) %PTO0 direction in CW/CCW output mode, or %PTO1 (not available when %PTO0 is configured in CW/CCW output mode), or %PTOx direction in other cases.

(3) %Q0.2 and %Q0.3 are fast outputs on TM221C40U and TM221CE40U controllers

(4) %PTO2 on TM221C40U and TM221CE40U controllers, or %PTOx direction in other cases.

(5) %PTO2 direction in CW/CCW output mode on TM221C40U and TM221CE40U controllers, or %PTO3 (not available when %PTO2 is configured in CW/CCW output mode) on TM221C40U and TM221CE40U controllers, or %PTOx direction in other cases.

Fallback Modes (Behavior for Outputs in Stop)

When the controller enters the STOPPED or one of the exception states for any reason, the local (embedded and expansion) outputs are set to **Default Value** defined in the application.

In case of PTO outputs, the fallback values are forced to 0 logic (0 Vdc) and these values cannot be modified.

Short-circuit or Over-current on Source Transistor Outputs

Outputs are clustered in packs of 4 outputs maximum (less when the total number of outputs of the controller is not a multiple of 4):

- **Q0...Q3**
- **Q4...Q7**
- **Q8...Q11**
- **Q12...Q15**

When a short-circuit or overload is detected and the system bit %S49 is set to 1, the cluster of 4 outputs is set to 0. An automatic rearming is done periodically (about 1 s). Only the short-circuit between an output set to 1 and 0 V is detected. The short-circuit between an output set to 0 and 24 V is not detected.

NOTE: By default, %S49 is set to 0.

The following table describes the actions taken on short-circuits or overload of transistor outputs from Q0 to Q3:

If...	then...
If you have short-circuit at 0 V on transistor outputs	Transistor outputs automatically go into over-current protection or thermal protection mode. For more information, refer to transistor output wiring diagrams.

In the case of a short-circuit or current overload, the common group of outputs automatically enters into thermal protection mode (all outputs in the group are set to 0), and are then periodically rearmed (each second) to test the connection state. However, you must be aware of the effect of this rearming on the machine or process being controlled.

⚠ WARNING

UNINTENDED MACHINE START-UP

Inhibit the automatic rearming of outputs if this feature is an undesirable behavior for your machine or process.

Failure to follow these instructions can result in death, serious injury, or equipment damage.

NOTE: The automatic rearming feature can be disabled with the system bit %S49. Refer to the Programming Guide of your controller for more information.

Short-circuit or Over-Current on Sink Transistor Outputs

Sink transistor outputs are not internally protected against overloads or short-circuits.

The following table describes the actions taken on overloads or short-circuits on sink transistor outputs:

If...	then ...
If you have short-circuit or overload at 0 V, or 24 V on sink transistor outputs	no action is taken and no error is detectable.

For more information, refer to Sink Transistor Outputs Wiring Diagrams, page 172.

Short-circuit or Over-Current on Relay Outputs

Relay outputs are not internally protected against overloads or short-circuits.

The following table describes the actions taken on overloads or short-circuits on relay outputs:

If...	then...
If you have short-circuit or overload at 0 V or 24 V on relay outputs	No action is taken and no error is detectable. For more information, refer to relay output wiring diagrams.

Relay outputs are electromechanical switches capable of carrying significant levels of current and voltage. All electromechanical devices have a limited operational life and must be installed so as to minimize the potential for unintended consequences.

▲ WARNING
<p>INOPERABLE OUTPUTS</p> <p>Use appropriate, external safety interlocks on outputs where personnel and/or equipment hazards exist.</p> <p>Failure to follow these instructions can result in death, serious injury, or equipment damage.</p>

Run/Stop

Overview

The M221 Logic Controller can be operated externally by the following:

- a hardware Run/Stop switch
- a Run/Stop, page 49 operation by a dedicated digital input, defined in the software configuration. For more information, refer to Configuring Digital Inputs (see Modicon M221, Logic Controller, Programming Guide).
- an EcoStruxure Machine Expert - Basic software command.
- a Remote Graphic Display (see Modicon TMH2GDB, Remote Graphic Display, User Guide).

The M221 Logic Controller has a Run/Stop hardware switch, which puts the controller in a RUN or STOP state.

The following figure shows the location of the Run/Stop switch on the TM221C Logic Controller:

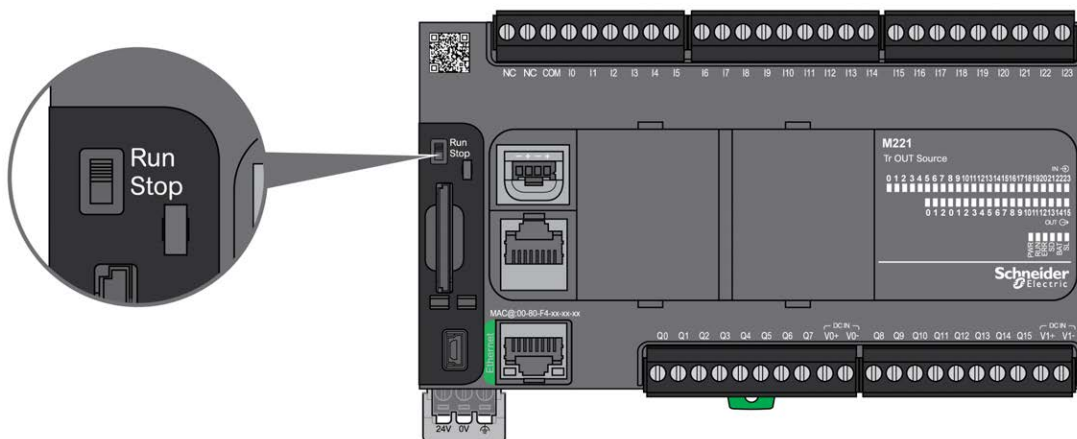

The following figure shows the location of the Run/Stop switch on the TM221M Logic Controller:

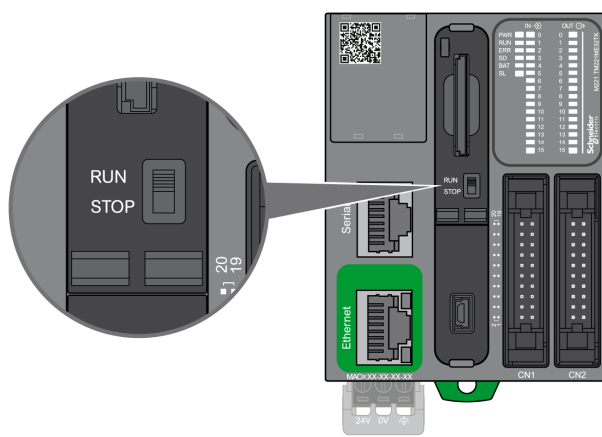

The interaction of the different operators on the controller state behavior is summarized in the table below:

		Embedded Run/Stop hardware switch		
		Switch on Stop	Stop to Run transition	Switch on Run
Software configurable Run/Stop digital input	None	STOP Ignores external Run/Stop commands ² .	Commands a transition to RUN state ¹ .	Allows external Run/Stop commands ² .
	State 0	STOP Ignores external Run/Stop commands ² .	STOP Ignores external Run/Stop commands ² .	STOP Ignores external Run/Stop commands ² .
	Rising edge	STOP Ignores external Run/Stop commands ² .	Commands a transition to RUN state ¹ .	Commands a transition to RUN state ¹ .
	State 1	STOP Ignores external Run/Stop commands ² .	Commands a transition to RUN state ¹ .	Allows external Run/Stop commands ² .

¹ For more information, refer to the Controller States and Behaviors (see Modicon M221, Logic Controller, Programming Guide).

² External Run/Stop commands sent by the EcoStruxure Machine Expert - Basic online button or a Remote Graphic Display.

▲ WARNING

UNINTENDED MACHINE OR PROCESS START-UP

- Verify the state of security of your machine or process environment before applying power to the Run/Stop input or engaging the Run/Stop switch.
- Use the Run/Stop input to help prevent the unintentional start-up from a remote location, or from accidentally engaging the Run/Stop switch.

Failure to follow these instructions can result in death, serious injury, or equipment damage.

SD Card

Overview

When handling the SD card, follow the instructions below to help prevent internal data on the SD card from being corrupted or lost or an SD card malfunction from occurring:

NOTICE

LOSS OF APPLICATION DATA

- Do not store the SD card where there is static electricity or probable electromagnetic fields.
- Do not store the SD card in direct sunlight, near a heater, or other locations where high temperatures can occur.
- Do not bend the SD card.
- Do not drop or strike the SD card against another object.
- Keep the SD card dry.
- Do not touch the SD card connectors.
- Do not disassemble or modify the SD card.
- Use only SD cards formatted using FAT or FAT32.

Failure to follow these instructions can result in equipment damage.

The M221 Logic Controller does not recognize NTFS formatted SD cards. Format the SD card on your computer using FAT or FAT32.

When using the M221 Logic Controller and an SD card, observe the following to avoid losing valuable data:

- Accidental data loss can occur at any time. Once data is lost it cannot be recovered.
- If you forcibly extract the SD card, data on the SD card may become corrupted.
- Removing an SD card that is being accessed could damage the SD card, or corrupt its data.
- If the SD card is not positioned correctly when inserted into the controller, the data on the card and the controller could become damaged.

NOTICE

LOSS OF APPLICATION DATA

- Backup SD card data regularly.
- Do not remove power or reset the controller, and do not insert or remove the SD card while it is being accessed.

Failure to follow these instructions can result in equipment damage.

The following figure shows the SD card slot of the TM221C Logic Controller:

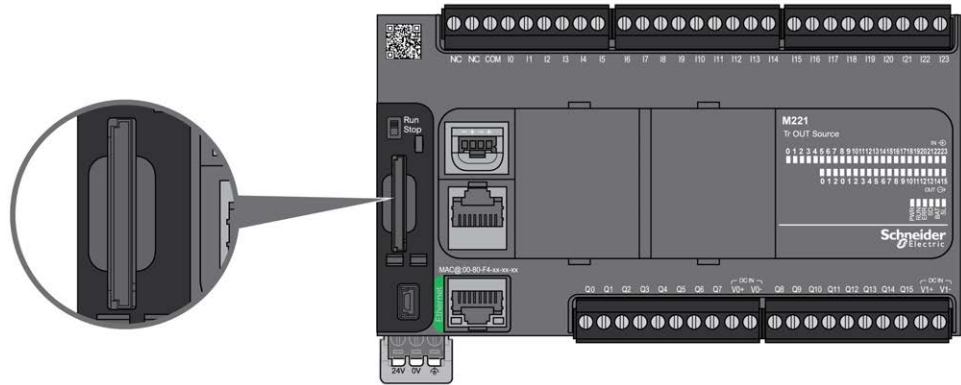

The following figure shows the SD card slot of the TM221M Logic Controller:

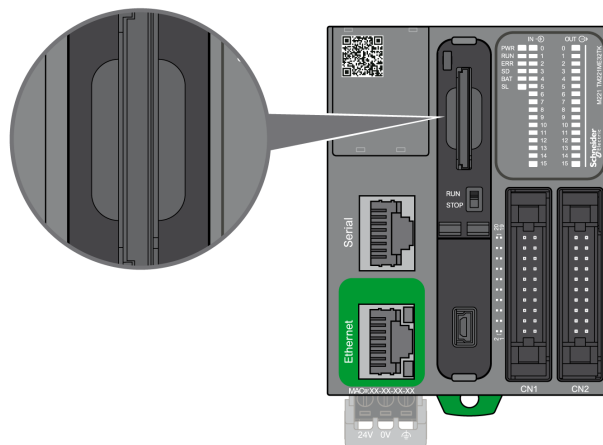

It is possible to set the Write-Control Tab to prevent write operations to the SD card. Push the tab up, as shown in the example on the right-hand side, to release the lock and enable writing to the SD card. Before using an SD card, read the manufacturer's instructions.

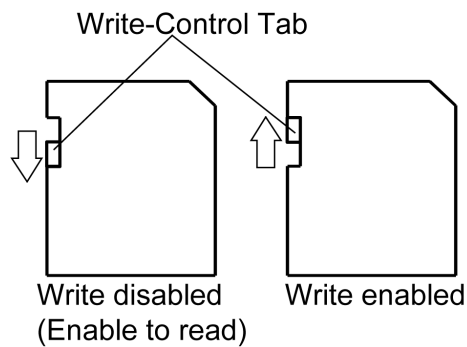

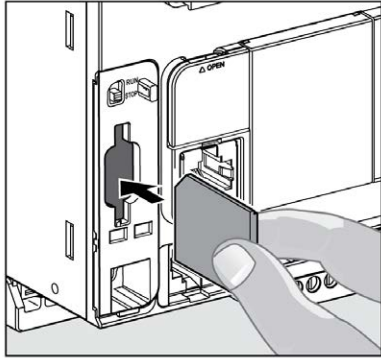
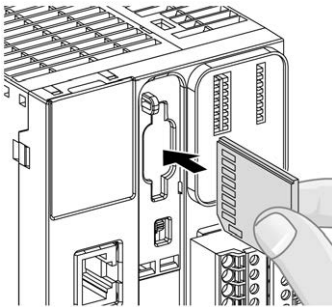
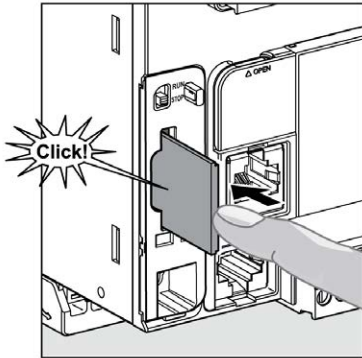
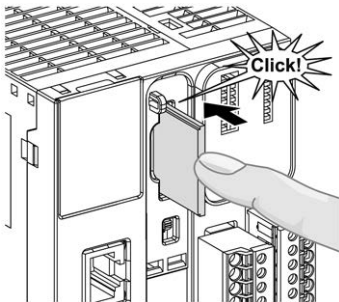
Step	Action
1	<p data-bbox="651 174 1362 203">1a. Insert the SD card into the SD card slot of the TM221C Logic Controller:</p>  <p data-bbox="651 602 1362 631">1b. Insert the SD card into the SD card slot of the TM221M Logic Controller:</p> 
2	<p data-bbox="651 976 1209 1005">2a. Push until you hear it “click” (TM221C Logic Controller):</p>  <p data-bbox="651 1404 1209 1433">2b. Push until you hear it “click” (TM221M Logic Controller):</p> 

SD Card Slot Characteristics

Topic	Characteristics	Description
Supported type	Standard Capacity	SD (SDSC)
	High Capacity	SDHC
Global memory	Size	32 GB maximum
Memory organization	Application backup size	64 MB
	Data storage size	1.93 GB
Robustness	Write/erase cycles (typical)	100,000
	Temperature operating range	-40...85 °C (-40...185 °F)
	File retention time	10 years

TMASD1 Characteristics

Characteristics	Description
Card removal durability	Minimum 1000 times
File retention time	10 years at 25 °C (77 °F)
Flash type	SLC NAND
Memory size	256 MB
Ambient operation temperature	-10...85 °C (14...185 °F)
Storage temperature	-25...85 °C (-13...185 °F)
Relative humidity	95% maximum non-condensing
Write/Erase cycles	3,000,000 (approximately)

Status LED

The following figure shows the status LEDs of the TM221C Logic Controller:



The following figure shows the status LEDs of the TM221M Logic Controller:

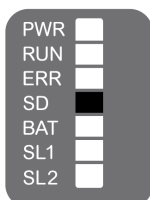

The following table describes the SD card status LED:

Label	Description	LED		
		Color	Status	Description
SD	SD card	Green	On	Indicates that the SD card is being accessed.
			Off	Indicates no access.
			Flashing	Indicates that an error was detected during the SD card operation.

M221 Installation

What's in This Chapter

M221 Logic Controller General Rules for Implementing	60
M221 Logic Controller Installation	63
M221 Electrical Requirements	74

Overview

This chapter provides installation safety guidelines, device dimensions, mounting instructions, and environmental specifications.

M221 Logic Controller General Rules for Implementing

Environmental Characteristics

Enclosure Requirements

M221 Logic Controller system components are designed as Zone B, Class A industrial equipment according to IEC/CISPR Publication 11. If they are used in environments other than those described in the standard, or in environments that do not meet the specifications in this manual, the ability to meet electromagnetic compatibility requirements in the presence of conducted and/or radiated interference may be reduced.

All M221 Logic Controller system components meet European Community (CE) requirements for open equipment as defined by IEC/EN 61131-2. You must install them in an enclosure designed for the specific environmental conditions and to minimize the possibility of unintended contact with hazardous voltages. Use metal enclosures to improve the electromagnetic immunity of your M221 Logic Controller system. Use enclosures with a keyed locking mechanism to minimize unauthorized access.

Environmental Characteristics

All the M221 Logic Controller module components are electrically isolated between the internal electronic circuit and the input/output channels within the limits set forth and described by these environmental characteristics. For more information on electrical isolation, see the technical specifications of your particular controller found later in the current document. This equipment meets CE requirements as indicated in the table below. This equipment is intended for use in a Pollution Degree 2 industrial environment.

⚠ WARNING

UNINTENDED EQUIPMENT OPERATION

Do not exceed any of the rated values specified in the environmental and electrical characteristics tables.

Failure to follow these instructions can result in death, serious injury, or equipment damage.

The following table shows the general environmental characteristics:

Characteristic	Minimum Specification	Tested Range	
Standard compliance	IEC/EN 61010-2-201	–	
Ambient operating temperature	–	Horizontal installation	–10...55 °C (14...131 °F)
	–	Vertical installation	–10...50 °C (14...122 °F) –10...35 °C (14...95 °F)
Storage temperature	–	–25...70 °C (- 13...158 °F)	
Relative humidity	–	Transport and storage	10...95 % (non-condensing)
		Operation	10...95 % (non-condensing)
Degree of pollution	IEC/EN 60664-1	2	
Degree of protection	IEC/EN 61131-2	IP20 with protective covers in place	
Corrosion immunity	–	Atmosphere free from corrosive gases	
Operating altitude	–	0...2000 m (0...6560 ft)	
Storage altitude	–	0...3000 m (0...9843 ft)	
Vibration resistance	IEC/EN 61131-2	Panel mounting or mounted on a top hat section rail (DIN rail)	3.5 mm (0.13 in) fixed amplitude from 5...8.4 Hz 29.4 m/s ² (96.45 ft/s ²) (3 g _n) fixed acceleration from 8.4...150 Hz
Mechanical shock resistance	–	147 m/s ² or 482.28 ft/s ² (15 g _n) for a duration of 11 ms 98 m/s ² or 32.15 ft/s ² (10 g _n) for a duration of 11 ms (for M221 Logic Controller with relay outputs)	
<p>NOTE: The tested ranges may indicate values beyond that of the IEC Standard. However, our internal standards define what is necessary for industrial environments. In all cases, we uphold the minimum specification if indicated.</p>			

Electromagnetic Susceptibility

The M221 Logic Controller system meets electromagnetic susceptibility specifications as indicated in the following table:

Characteristic	Minimum Specification	Tested Range		
Electrostatic discharge	IEC/EN 61000-4-2	8 kV (air discharge) 4 kV (contact discharge)		
Radiated electromagnetic field	IEC/EN 61000-4-3	10 V/m (80...1000 MHz) 3 V/m (1.4...2 GHz) 1 V/m (2...3 GHz)		
Magnetic field	IEC/EN 61000-4-8	30 A/m 50 Hz, 60 Hz		
Fast transients burst	IEC/EN 61000-4-4	–	CM ¹ and DM ²	
		AC/DC Power lines	2 kV	
		Relay outputs	2 kV	
		24 Vdc I/Os	1 kV	
		Analog I/Os	1 kV	
		Communication line	1 kV	
Surge immunity	IEC/EN 61000-4-5 IEC/EN 61131-2	–	CM ¹	DM ²
		DC Power lines	1 kV	0.5 kV
		AC Power lines	2 kV	1 kV
		Relay outputs	2 kV	1 kV
		24 Vdc I/Os	1 kV	–
		Shielded cable (between shield and ground)	1 kV	–
Induced electromagnetic field	IEC/EN 61000-4-6	10 Vrms (0.15...80 MHz)		
Conducted emission	IEC 61000-6-4	AC power line: <ul style="list-style-type: none"> • 0.15...0.5 MHz: 79 dBμV/m QP / 66 dBμV/m AV • 0.5...300 MHz: 73 dBμV/m QP / 60 dBμV/m AV AC/DC power line: <ul style="list-style-type: none"> • 10...150 kHz: 120...69 dBμV/m QP • 150...1500 kHz: 79...63 dBμV/m QP • 1.5...30 MHz: 63 dBμV/m QP 		
Radiated emission	IEC 61000-6-4	30...230 MHz: 40 dB μ V/m QP 230...1000 MHz: 47 dB μ V/m QP		
1 Common Mode 2 Differential Mode NOTE: The tested ranges may indicate values beyond that of the IEC Standard. However, our internal standards define what is necessary for industrial environments. In all cases, we uphold the minimum specification if indicated.				

Certifications and Standards

Introduction

For information on certifications and conformance to standards, go to www.se.com.

For product compliance and environmental information (RoHS, REACH, PEP, EOL, etc.), go to www.se.com/green-premium.

M221 Logic Controller Installation

Installation and Maintenance Requirements

Before Starting

Read and understand this chapter before beginning the installation of your system.

The use and application of the information contained herein require expertise in the design and programming of automated control systems. Only you, the user, machine builder or integrator, can be aware of all the conditions and factors present during installation and setup, operation, and maintenance of the machine or process, and can therefore determine the automation and associated equipment and the related safeties and interlocks which can be effectively and properly used. When selecting automation and control equipment, and any other related equipment or software, for a particular application, you must also consider any applicable local, regional or national standards and/or regulations.

Pay particular attention in conforming to any safety information, different electrical requirements, and normative standards that would apply to your machine or process in the use of this equipment.

Disconnecting Power

All options and modules should be assembled and installed before installing the control system on a mounting rail, onto a mounting plate or in a panel. Remove the control system from its mounting rail, mounting plate or panel before disassembling the equipment.

 DANGER
HAZARD OF ELECTRIC SHOCK, EXPLOSION OR ARC FLASH
<ul style="list-style-type: none">• Disconnect all power from all equipment including connected devices prior to removing any covers or doors, or installing or removing any accessories, hardware, cables, or wires except under the specific conditions specified in the appropriate hardware guide for this equipment.• Always use a properly rated voltage sensing device to confirm the power is off where and when indicated.• Replace and secure all covers, accessories, hardware, cables, and wires and confirm that a proper ground connection exists before applying power to the unit.• Use only the specified voltage when operating this equipment and any associated products.
Failure to follow these instructions will result in death or serious injury.

Programming Considerations

 WARNING
UNINTENDED EQUIPMENT OPERATION
<ul style="list-style-type: none">• Only use software approved by Schneider Electric for use with this equipment.• Update your application program every time you change the physical hardware configuration.
Failure to follow these instructions can result in death, serious injury, or equipment damage.

Operating Environment

In addition to the **Environmental Characteristics**, refer to **Product Related Information** in the beginning of the present document for important information regarding installation in hazardous locations for this specific equipment.

▲ WARNING

UNINTENDED EQUIPMENT OPERATION

Install and operate this equipment according to the conditions described in the Environmental Characteristics.

Failure to follow these instructions can result in death, serious injury, or equipment damage.

Installation Considerations

▲ WARNING

UNINTENDED EQUIPMENT OPERATION

- Use appropriate safety interlocks where personnel and/or equipment hazards exist.
- Install and operate this equipment in an enclosure appropriately rated for its intended environment and secured by a keyed or tooled locking mechanism.
- Use the sensor and actuator power supplies only for supplying power to the sensors or actuators connected to the module.
- Power line and output circuits must be wired and fused in compliance with local and national regulatory requirements for the rated current and voltage of the particular equipment.
- Do not use this equipment in safety-critical machine functions unless the equipment is otherwise designated as functional safety equipment and conforming to applicable regulations and standards.
- Do not disassemble, repair, or modify this equipment.
- Do not connect any wiring to reserved, unused connections, or to connections designated as No Connection (N.C.).

Failure to follow these instructions can result in death, serious injury, or equipment damage.

NOTE: JDYX2 or JDYX8 fuse types are cULus-recognized.

TM221C Logic Controller Mounting Positions and Clearances

Introduction

This section describes the mounting positions for the TM221C Logic Controller.

NOTE: Keep adequate spacing for proper ventilation and to maintain the operating temperature specified in the Environmental Characteristics, page 60.

Correct Mounting Position

Whenever possible, the TM221C Logic Controller should be mounted horizontally on a vertical plane as shown in the figure below:

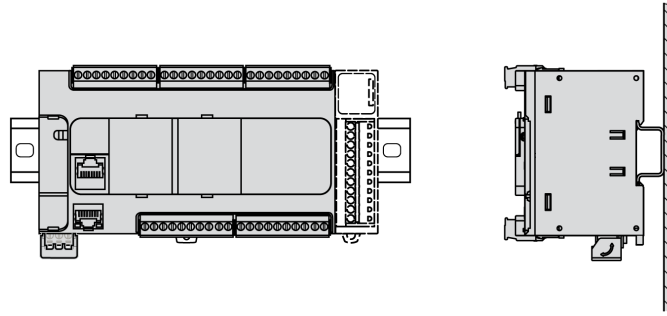

Acceptable Mounting Position

The TM221C Logic Controller can also be mounted vertically with a temperature derating on a vertical plane as shown below:

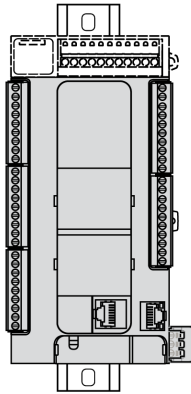

NOTE: Expansion modules must be mounted above the logic controller.

Incorrect Mounting Positions

The TM221C Logic Controller should only be positioned as shown in *Correct Mounting Position*, page 65 figure. The figures below show the incorrect mounting positions:

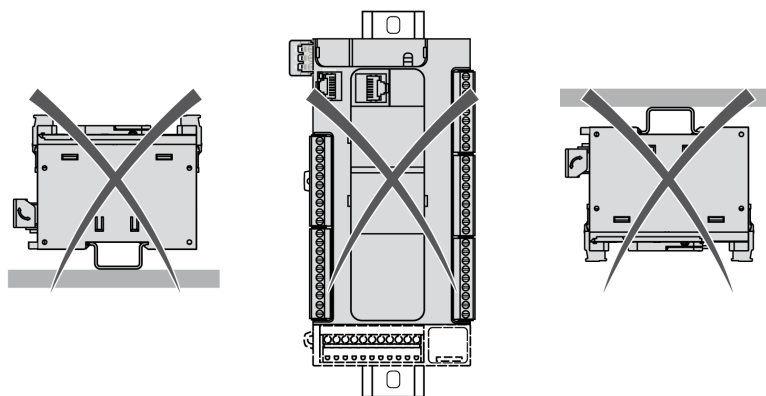

Minimum Clearances

⚠ WARNING

UNINTENDED EQUIPMENT OPERATION

- Place devices dissipating the most heat at the top of the cabinet and ensure adequate ventilation.
- Avoid placing this equipment next to or above devices that might cause overheating.
- Install the equipment in a location providing the minimum clearances from all adjacent structures and equipment as directed in this document.
- Install all equipment in accordance with the specifications in the related documentation.

Failure to follow these instructions can result in death, serious injury, or equipment damage.

The M221 Logic Controller has been designed as an IP20 product and must be installed in an enclosure. Clearances must be respected when installing the product.

There are 3 types of clearances between:

- The M221 Logic Controller and all sides of the cabinet (including the panel door).
- The M221 Logic Controller terminal blocks and the wiring ducts. This distance reduces electromagnetic interference between the controller and the wiring ducts.
- The M221 Logic Controller and other heat generating devices installed in the same cabinet.

The following figure shows the minimum clearances that apply to all TM221C Logic Controller references:

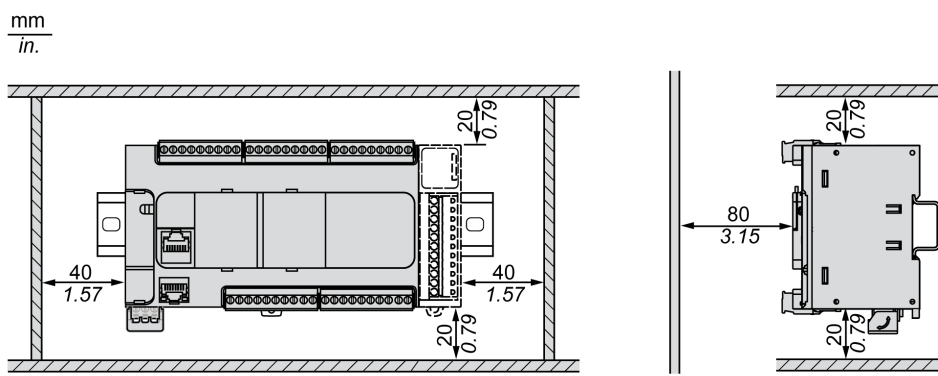

TM221M Logic Controller Mounting Positions and Clearances

Introduction

This section describes the mounting positions for the M221 Logic Controller.

NOTE: Keep adequate spacing for proper ventilation and to maintain the operating temperature specified in the *Environmental Characteristics*, page 60.

Correct Mounting Position

To obtain optimal operating characteristics, the M221 Logic Controller should be mounted horizontally on a vertical plane as shown in the figure below:

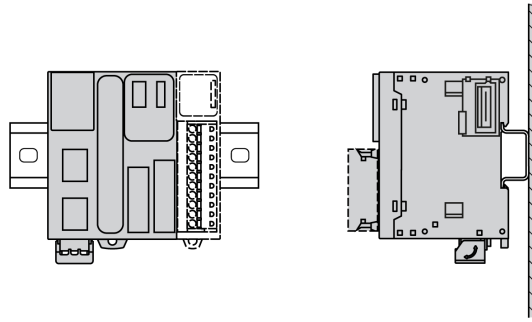

Acceptable Mounting Position

The M221 Logic Controller can also be mounted vertically on a vertical plane as shown below:

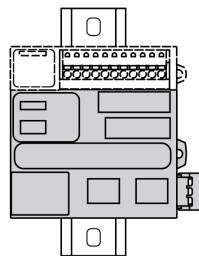

NOTE: Expansion modules must be mounted above the controller.

Incorrect Mounting Positions

The M221 Logic Controller should only be positioned as shown in the [Correct Mounting Position](#), page 67 figure. The figures below show the incorrect mounting positions:

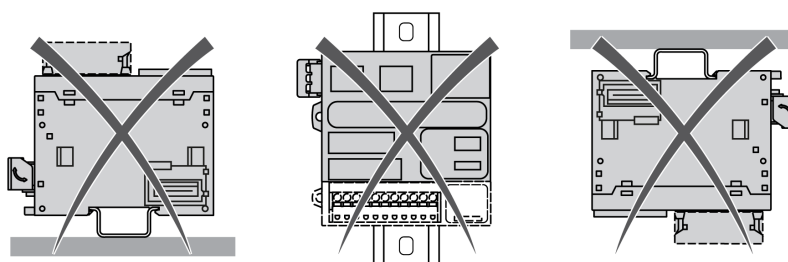

Minimum Clearances

⚠ WARNING

UNINTENDED EQUIPMENT OPERATION

- Place devices dissipating the most heat at the top of the cabinet and ensure adequate ventilation.
- Avoid placing this equipment next to or above devices that might cause overheating.
- Install the equipment in a location providing the minimum clearances from all adjacent structures and equipment as directed in this document.
- Install all equipment in accordance with the specifications in the related documentation.

Failure to follow these instructions can result in death, serious injury, or equipment damage.

The M221 Logic Controller has been designed as an IP20 product and must be installed in an enclosure. Clearances must be respected when installing the product.

There are 3 types of clearances to consider:

- The M221 Logic Controller and all sides of the cabinet (including the panel door).
- The M221 Logic Controller terminal blocks and the wiring ducts to help reduce potential electromagnetic interference between the controller and the duct wiring.
- The M221 Logic Controller and other heat generating devices installed in the same cabinet.

The following figure shows the minimum clearances that apply to all M221 Logic Controller references:

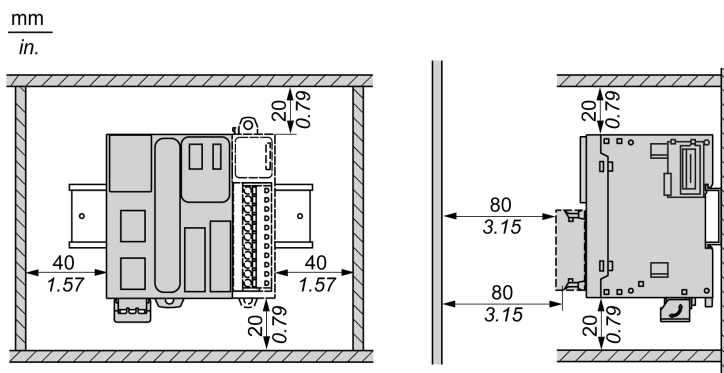

Top Hat Section Rail (DIN rail)

Dimensions of Top Hat Section Rail DIN Rail

You can mount the controller or receiver and their expansions on a 35 mm (1.38 in.) top hat section rail (DIN rail). The DIN rail can be attached to a smooth mounting surface or suspended from an EIA rack or mounted in a NEMA cabinet.

Symmetric Top Hat Section Rails (DIN Rail)

The following illustration and table indicate the references of the top hat section rails (DIN rail) for the wall-mounting range:

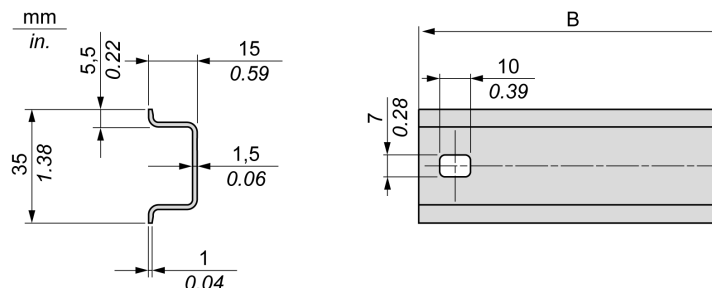

Reference	Type	Perforated	Rail Length (B)
NSYS DR50A	A	At each end	450 mm (17.71 in.)
NSYS DR60A	A	At each end	550 mm (21.65 in.)
NSYS DR80A	A	At each end	750 mm (29.52 in.)
NSYS DR100A	A	At each end	950 mm (37.40 in.)

The following illustration and table indicate the references of the symmetric top hat section rails (DIN rail) of 2000 mm (78.74 in.):

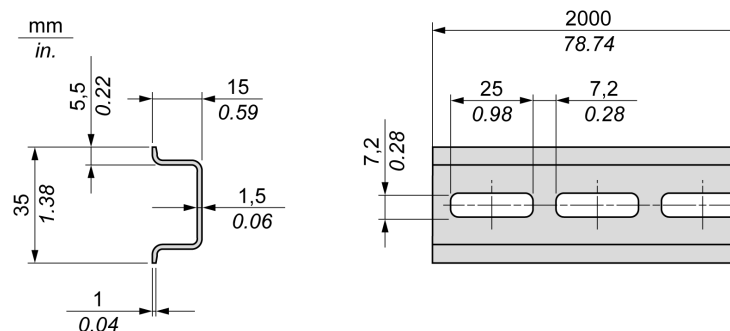

Reference	Type	Perforated	Rail Length
NSYS DR200	A	No	2000 mm (78.74 in.)
NSYS DR200D	A	Yes	

Double-Profile Top Hat Section Rails (DIN rail)

The following illustration and table indicate the references of the double-profile top hat section rails (DIN rail) of 2000 mm (78.74 in.):

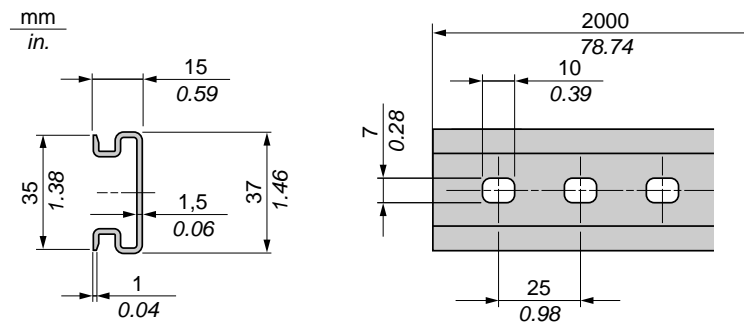

Reference	Type	Perforated	Rail Length
NSYDPR200	–	No	2000 mm (78.74 in.)
NSYDPR200D	–	Yes	

Installing and Removing the Controller with Expansions

Overview

This section describes how to install and remove the controller with its expansion modules from a top hat section rail (DIN rail).

To assemble expansion modules to a controller or receiver module, or to other modules, refer to the respective expansion modules hardware guide(s).

Installing a Controller with its Expansions on a DIN Rail

The following procedure describes how to install a controller with its expansion modules on a top hat section rail (DIN rail):

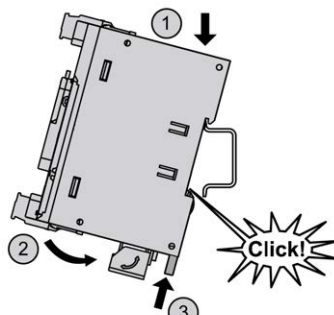
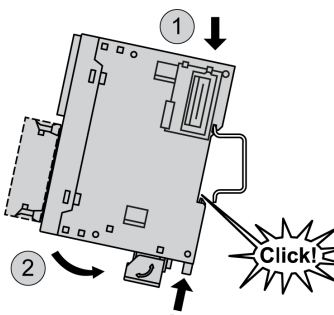
Step	Action
1	Fasten the top hat section rail (DIN rail) to a panel surface using screws.
2	<p>Position the top groove of the controller and its expansion modules on the top edge of the DIN rail and press the assembly against the top hat section rail (DIN rail) until you hear the top hat section rail (DIN rail) clip snap into place.</p> <p>On TM221C Logic Controller:</p>  <p>On TM221M Logic Controller:</p> 
3	<p>Place 2 terminal block end clamps on both sides of the controller and expansion module assembly.</p> <p>NOTE: Type NSYTRAAB35 or equivalent terminal block end clamps help minimize sideways movement and improve the shock and vibration characteristics of the controller and expansion module assembly.</p>

Removing a Controller with its Expansions from a Top Hat Section Rail (DIN Rail)

The following procedure describes how to remove a controller with its expansion modules from a top hat section rail (DIN rail):

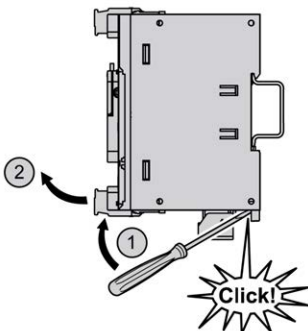
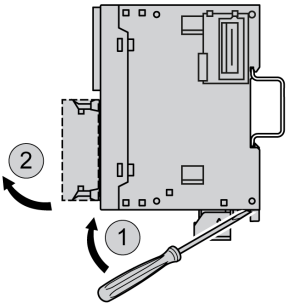
Step	Action
1	Remove all power from your controller and expansion modules.
2	<p>Insert a flat screwdriver into the slot of the top hat section rail (DIN rail) clip.</p> <p>On TM221C Logic Controller:</p>  <p>On TM221M Logic Controller:</p> 
3	Pull down the DIN rail clip.
4	Pull the controller and its expansion modules from the top hat section rail (DIN rail) from the bottom.

Direct Mounting on a Panel Surface

Overview

This section shows how to install M221 Logic Controller using the Panel Mounting Kit. This section also provides mounting hole layout for all modules.

Installing the Panel Mounting Kit

The following procedure shows how to install a mounting strip:

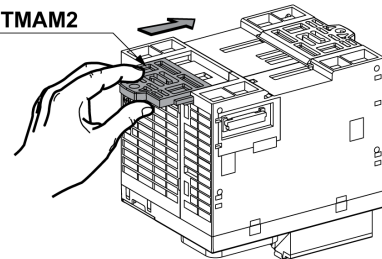
Step	Action
1	Insert the mounting strip TMAM2 into the slot at the top of the module. 

Mounting Hole Layout

The following diagram shows the mounting hole layout for TM221C Logic Controller with 16 I/O channels:

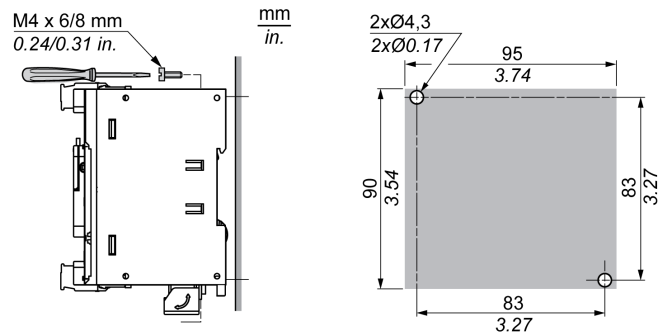

The following diagram shows the mounting hole layout for TM221C Logic Controller with 24 I/O channels:

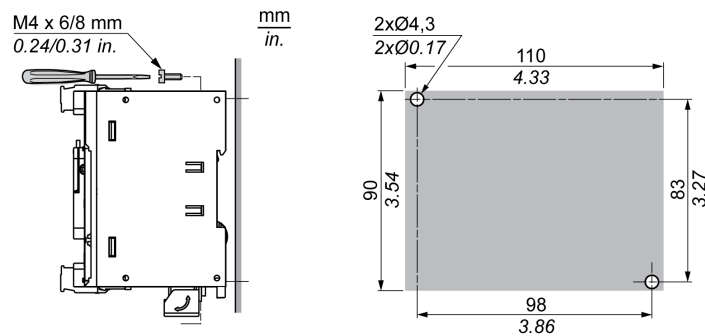

The following diagram shows the mounting hole layout for TM221C Logic Controller with 40 I/O channels:

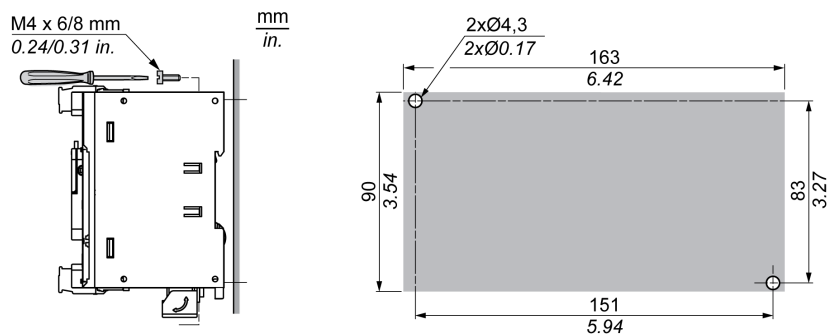

The following diagram shows the mounting hole layout for TM221M Logic Controller:

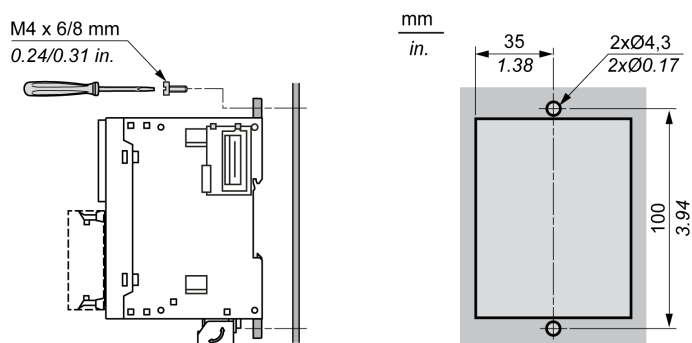

M221 Electrical Requirements

Wiring Best Practices

Overview

This section describes the wiring guidelines and associated best practices to be respected when using the M221 Logic Controller system.

⚡⚠ DANGER

HAZARD OF ELECTRIC SHOCK, EXPLOSION OR ARC FLASH

- Disconnect all power from all equipment including connected devices prior to removing any covers or doors, or installing or removing any accessories, hardware, cables, or wires except under the specific conditions specified in the appropriate hardware guide for this equipment.
- Always use a properly rated voltage sensing device to confirm the power is off where and when indicated.
- Replace and secure all covers, accessories, hardware, cables, and wires and confirm that a proper ground connection exists before applying power to the unit.
- Use only the specified voltage when operating this equipment and any associated products.

Failure to follow these instructions will result in death or serious injury.

▲ WARNING

LOSS OF CONTROL

- Perform a Failure Mode and Effects Analysis (FMEA), or equivalent risk analysis, of your application, and apply preventive and detective controls before implementation.
- Provide a fallback state for undesired control events or sequences.
- Provide separate or redundant control paths wherever required.
- Supply appropriate parameters, particularly for limits.
- Review the implications of transmission delays and take actions to mitigate them.
- Review the implications of communication link interruptions and take actions to mitigate them.
- Provide independent paths for control functions (for example, emergency stop, over-limit conditions, and error conditions) according to your risk assessment, and applicable codes and regulations.
- Apply local accident prevention and safety regulations and guidelines.¹
- Test each implementation of a system for proper operation before placing it into service.

Failure to follow these instructions can result in death, serious injury, or equipment damage.

¹ For additional information, refer to NEMA ICS 1.1 (latest edition), *Safety Guidelines for the Application, Installation, and Maintenance of Solid State Control* and to NEMA ICS 7.1 (latest edition), *Safety Standards for Construction and Guide for Selection, Installation and Operation of Adjustable-Speed Drive Systems* or their equivalent governing your particular location.

Wiring Guidelines

The following rules must be applied when wiring a M221 Logic Controller system:

- I/O and communication wiring must be kept separate from the power wiring. Route these 2 types of wiring in separate cable ducting.
- Verify that the operating conditions and environment are within the specification values.
- Use proper wire sizes to meet voltage and current requirements.
- Use copper conductors (required).
- Use twisted pair, shielded cables for analog, and/or fast I/O.
- Use twisted pair, shielded cables for networks, and fieldbus.

Use shielded, properly grounded cables for all analog and high-speed inputs or outputs and communication connections. If you do not use shielded cable for these connections, electromagnetic interference can cause signal degradation. Degraded signals can cause the controller or attached modules and equipment to perform in an unintended manner.

▲ WARNING

UNINTENDED EQUIPMENT OPERATION

- Use shielded cables for all fast I/O, analog I/O and communication signals.
- Ground cable shields for all analog I/O, fast I/O and communication signals at a single point¹.
- Route communication and I/O cables separately from power cables.

Failure to follow these instructions can result in death, serious injury, or equipment damage.

¹Multipoint grounding is permissible if connections are made to an equipotential ground plane dimensioned to help avoid cable shield damage in the event of power system short-circuit currents.









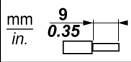

For more details, refer to *Grounding Shielded Cables*, page 85.

NOTE: Surface temperatures may exceed 60 °C (140 °F).









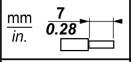

To conform to IEC 61010 standards, route primary wiring (wires connected to power mains) separately and apart from secondary wiring (extra low voltage wiring coming from intervening power sources). If that is not possible, double insulation is required such as conduit or cable gains.

Rules for Removable Screw Terminal Block

The following tables show the cable types and wire sizes for a **3.81 pitch** removable screw terminal block (I/Os and power supply):

								
mm in.	9							
mm ²	0.14...1.5	0.14...1.5	0.25...1.5	0.25...0.5	2 x 0.14...0.5	2 x 0.14...0.75	2 x 0.25...0.34	2 x 0.5
AWG	26...16	26...16	22...16	22...20	2 x 26...20	2 x 26...20	2 x 24...22	2 x 20
		N•m		0.28				
Ø 2,5 mm (0.1 in.)		lb-in		2.48				

The following tables show the cable types and wire sizes for a **5.08 pitch** removable screw terminal block (I/Os and power supply):

								
mm in.	7							
mm ²	0.2...2.5	0.2...2.5	0.25...2.5	0.25...2.5	2 x 0.2...1	2 x 0.2...1.5	2 x 0.25...1	2 x 0.5...1.5
AWG	24...14	24...14	22...14	22...14	2 x 24...18	2 x 24...16	2 x 22...18	2 x 20...16
		N•m		0.51				
Ø 3,5 mm (0.14 in.)		lb-in		4.5				

The use of copper conductors is required.

DANGER

LOOSE WIRING CAUSES ELECTRIC SHOCK

Tighten connections in conformance with the torque specifications.

Failure to follow these instructions will result in death or serious injury.

DANGER

FIRE HAZARD

- Use only the correct wire sizes for the maximum current capacity of the I/O channels and power supplies.
- For relay output (2 A) wiring, use conductors of at least 0.5 mm² (AWG 20) with a temperature rating of at least 80 °C (176 °F).
- For common conductors of relay output wiring (7 A), or relay output wiring greater than 2 A, use conductors of at least 1.0 mm² (AWG 16) with a temperature rating of at least 80 °C (176 °F).

Failure to follow these instructions will result in death or serious injury.

Rules for Removable Spring Terminal Block

The following tables show the cable types and wire sizes for a **3.81 pitch** removable spring terminal block (I/Os and power supply):

mm in.					
	9 0.35				
mm ²		0.2...1.5	0.2...1.5	0.25...1.0	0.25...0.5
AWG		24...16	24...16	23...18	23...21

The following tables show the cable types and wire sizes for a **5.08 pitch** removable spring terminal block (I/Os and power supply):

mm in.						
	10 0.39					
mm ²		0.2...2.5	0.2...2.5	0.25...2.5	0.25...2.5	2 x 0.5...1
AWG		24...14	24...14	23...14	23...14	2 x 20...17

The use of copper conductors is required.

⚠ DANGER

FIRE HAZARD

- Use only the correct wire sizes for the maximum current capacity of the I/O channels and power supplies.
- For relay output (2 A) wiring, use conductors of at least 0.5 mm² (AWG 20) with a temperature rating of at least 80 °C (176 °F).
- For common conductors of relay output wiring (7 A), or relay output wiring greater than 2 A, use conductors of at least 1.0 mm² (AWG 16) with a temperature rating of at least 80 °C (176 °F).

Failure to follow these instructions will result in death or serious injury.

The spring clamp connectors of the terminal block are designed for only one wire or one cable end. Two wires to the same connector must be installed with a double wire cable end to help prevent loosening.

⚠ ⚠ DANGER

LOOSE WIRING CAUSES ELECTRIC SHOCK

Do not insert more than one wire per connector of the spring terminal blocks unless using a double wire cable end (ferrule).

Failure to follow these instructions will result in death or serious injury.

Removing the I/O Terminal Block

The following figure shows the removal of the I/O terminal block from the TM221C Logic Controller:

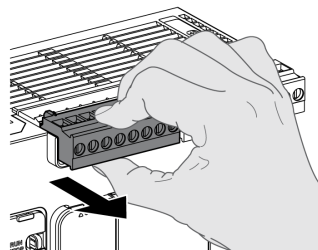

Protecting Outputs from Inductive Load Damage

Depending on the load, a protection circuit may be needed for the outputs on the controllers and certain modules. Inductive loads using DC voltages may create voltage reflections resulting in overshoot that will damage or shorten the life of output devices.

⚠ CAUTION

OUTPUT CIRCUIT DAMAGE DUE TO INDUCTIVE LOADS

Use an appropriate external protective circuit or device to reduce the risk of inductive direct current load damage.

Failure to follow these instructions can result in injury or equipment damage.

If your controller or module contains relay outputs, these types of outputs can support up to 240 Vac. Inductive damage to these types of outputs can result in welded contacts and loss of control. Each inductive load must include a protection device such as a peak limiter, RC circuit or flyback diode. Capacitive loads are not supported by these relays.

⚠ WARNING

RELAY OUTPUTS WELDED CLOSED

- Always protect relay outputs from inductive alternating current load damage using an appropriate external protective circuit or device.
- Do not connect relay outputs to capacitive loads.

Failure to follow these instructions can result in death, serious injury, or equipment damage.

AC-driven contactor coils are, under certain circumstances, inductive loads that generate pronounced high-frequency interference and electrical transients when the contactor coil is de-energized. This interference may cause the logic controller to detect an I/O bus error.

⚠ WARNING

CONSEQUENTIAL LOSS OF CONTROL

Install an RC surge suppressor or similar means, such as an interposing relay, on each TM3 expansion module relay output when connecting to AC-driven contactors or other forms of inductive loads.

Failure to follow these instructions can result in death, serious injury, or equipment damage.

Protective circuit A: this protection circuit can be used for both AC and DC load power circuits.

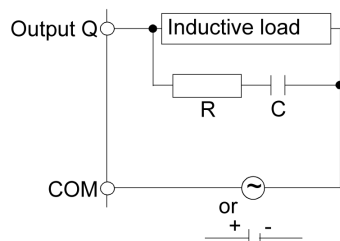

C Value from 0.1 to 1 μF

R Resistor of approximately the same resistance value as the load

Protective circuit B: this protection circuit can be used for DC load power circuits.

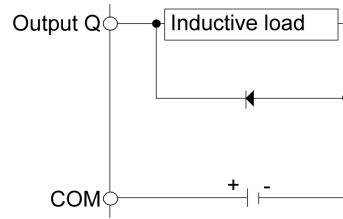

Use a diode with the following ratings:

- Reverse withstand voltage: power voltage of the load circuit x 10.
- Forward current: more than the load current.

Protective circuit C: this protection circuit can be used for both AC and DC load power circuits.

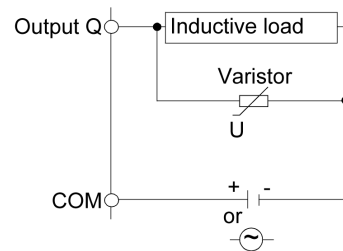

In applications where the inductive load is switched on and off frequently and/or rapidly, ensure that the continuous energy rating (J) of the varistor exceeds the peak load energy by 20 % or more.

DC Power Supply Characteristics and Wiring

Overview

This section provides the characteristics and the wiring diagrams of the DC power supply.

DC Power Supply Voltage Range

If the specified voltage range is not maintained, outputs may not switch as expected. Use appropriate safety interlocks and voltage monitoring circuits.

⚠ DANGER

FIRE HAZARD

- Use only the correct wire sizes for the maximum current capacity of the I/O channels and power supplies.
- For relay output (2 A) wiring, use conductors of at least 0.5 mm² (AWG 20) with a temperature rating of at least 80 °C (176 °F).
- For common conductors of relay output wiring (7 A), or relay output wiring greater than 2 A, use conductors of at least 1.0 mm² (AWG 16) with a temperature rating of at least 80 °C (176 °F).

Failure to follow these instructions will result in death or serious injury.

⚠ WARNING**UNINTENDED EQUIPMENT OPERATION**

Do not exceed any of the rated values specified in the environmental and electrical characteristics tables.

Failure to follow these instructions can result in death, serious injury, or equipment damage.

DC Power Supply Requirements

The M221 Logic Controller and associated I/O (TM2, TM3, and embedded I/O) require power supplies with a nominal voltage of 24 Vdc. The 24 Vdc power supplies must be rated Safety Extra Low Voltage (SELV) or Protective Extra Low Voltage (PELV) according to IEC 61140. These power supplies are isolated between the electrical input and output circuits of the power supply.

⚠ WARNING**POTENTIAL OF OVERHEATING AND FIRE**

- Do not connect the equipment directly to line voltage.
- Use only isolating PELV power supplies and circuits to supply power to the equipment¹.

Failure to follow these instructions can result in death, serious injury, or equipment damage.

¹ For compliance to UL (Underwriters Laboratories) requirements, the power supply must also conform to the various criteria of NEC Class 2, and be inherently current limited to a maximum power output availability of less than 100 VA (approximately 4 A at nominal voltage), or not inherently limited but with an additional protection device such as a circuit breaker or fuse meeting the requirements of clause 9.4 Limited-energy circuit of UL 61010-1. In all cases, the current limit should never exceed that of the electric characteristics and wiring diagrams for the equipment described in the present documentation. In all cases, the power supply must be grounded, and you must separate Class 2 circuits from other circuits. If the indicated rating of the electrical characteristics or wiring diagrams are greater than the specified current limit, multiple Class 2 power supplies may be used.

Controller DC Characteristics

The following table shows the DC power supply characteristics:

Characteristic		Value	
Rated voltage		24 Vdc	
Power supply voltage range		20.4...28.8 Vdc	
Power interruption time		10 ms at 24 Vdc	
Maximum inrush current		35 A	
Maximum power consumption	TM221C16T	with 4 expansion modules	10 W
	TM221CE16T		11 W
	TM221C16U		10 W
	TM221CE16U		11 W
	TM221C24T	with 7 expansion modules	13 W
	TM221CE24T		14 W
	TM221C24U		13 W
	TM221CE24U		14 W
	TM221C40T		16 W
	TM221CE40T		17 W
	TM221C40U		16 W
	TM221CE40U		17 W
	Maximum power consumption	TM221M16R•	with 7 expansion modules
TM221ME16R•		23.3 W	
TM221M16T•		22 W	
TM221ME16T•		22.9 W	
TM221M32TK		22.3 W	
TM221ME32TK		23.2 W	
Isolation	between DC power supply and internal logic	TM221C Logic Controller	500 Vac
		TM221M Logic Controller	Not isolated
	between DC power supply and protective earth ground (PE)		500 Vac

Power interruption

The TM221M Logic Controller must be supplied by an external 24 V power supply equipment. During power interruptions, the TM221M Logic Controller, associated to the suitable power supply, is able to continue normal operation for a minimum of 10 ms as specified by IEC standards.

When planning the management of the power supplied to the controller, you must consider the power interruption duration due to the fast cycle time of the controller.

There could potentially be many scans of the logic and consequential updates to the I/O image table during the power interruption, while there is no external power supplied to the inputs, the outputs or both depending on the power system architecture and power interruption circumstances.

⚠ WARNING

UNINTENDED EQUIPMENT OPERATION

- Individually monitor each source of power used in the controller system including input power supplies, output power supplies and the power supply to the controller to allow appropriate system shutdown during power system interruptions.
- The inputs monitoring each of the power supply sources must be unfiltered inputs.

Failure to follow these instructions can result in death, serious injury, or equipment damage.

DC Power Supply Wiring Diagram

The following figure shows the power supply terminal block removal procedure:

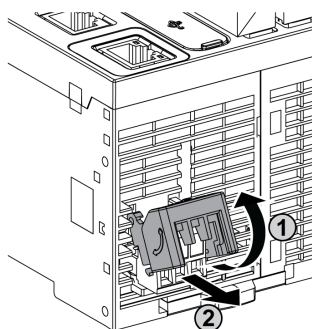

The following figure shows the wiring of the DC power supply:

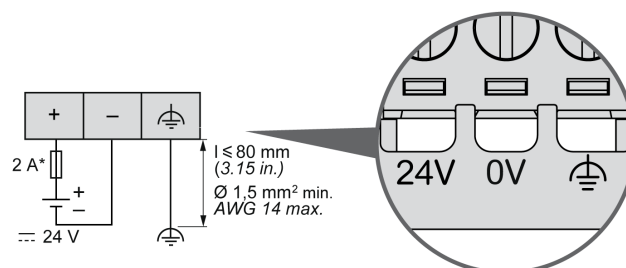

* Type T fuse

For more information, refer to the 5.08 pitch Rules for Removable Screw Terminal block, page 76.

AC Power Supply Characteristics and Wiring

Overview

This section provides the wiring diagrams and the characteristics of the AC power supply.

AC Power Supply Voltage Range

If the specified voltage range is not maintained, outputs may not switch as expected. Use appropriate safety interlocks and voltage monitoring circuits.

⚠ DANGER**FIRE HAZARD**

- Use only the correct wire sizes for the maximum current capacity of the I/O channels and power supplies.
- For relay output (2 A) wiring, use conductors of at least 0.5 mm² (AWG 20) with a temperature rating of at least 80 °C (176 °F).
- For common conductors of relay output wiring (7 A), or relay output wiring greater than 2 A, use conductors of at least 1.0 mm² (AWG 16) with a temperature rating of at least 80 °C (176 °F).

Failure to follow these instructions will result in death or serious injury.

⚠ WARNING**UNINTENDED EQUIPMENT OPERATION**

Do not exceed any of the rated values specified in the environmental and electrical characteristics tables.

Failure to follow these instructions can result in death, serious injury, or equipment damage.

Controller AC Characteristics

The following table shows the AC power supply characteristics:

Characteristic		Value	
Voltage	rated	100...240 Vac	
	limit (including ripple)	85...264 Vac	
Frequency	rated	50/60 Hz	
	limit	45/66 Hz	
Power interruption time		10 ms at 100 Vac	
Maximum inrush current	at 240 Vac	40 A	
Maximum power consumption at 100...240 Vac	TM221C16R	with 4 expansion modules	46 VA
	TM221CE16R		49 VA
	TM221C24R	with 7 expansion modules	55 VA
	TM221CE24R		58 VA
	TM221C40R		67 VA
	TM221CE40R		70 VA
Isolation	between AC power supply and internal logic	2300 Vac	
	between AC power supply and protective earth ground (PE)	1500 Vac	

Power interruption

The duration of power interruptions where the M221 Logic Controller is able to continue normal operation varies depending upon the load to the power supply of the controller, but generally a minimum of 10 ms is maintained as specified by IEC standards.

If there is a minimum load on the controller power supply, the interruption can be as long as 400 ms.

When planning the management of the power supplied to the controller, you must consider the duration due to the fast cycle time.

There could potentially be many scans of the logic and consequential updates to the I/O image table during the power interruption, while there is no external power supplied to the inputs, the outputs or both depending on the power system architecture and power interruption circumstances.

⚠ WARNING

UNINTENDED EQUIPMENT OPERATION

- Individually monitor each source of power used in the Modicon M221 Logic Controller system including input power supplies, output power supplies and the power supply to the controller to allow appropriate system shutdown during power system interruptions.
- The inputs monitoring each of the power supply sources must be unfiltered inputs.

Failure to follow these instructions can result in death, serious injury, or equipment damage.

AC Power Supply Wiring Diagram

The following figure shows the power supply terminal block removal procedure:

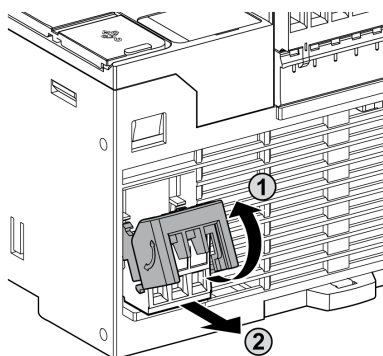

The following figure shows the wiring of the AC power supply:

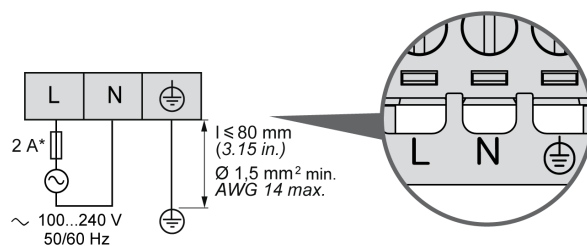

* Use an external, slow-blow, type T fuse.

Grounding the M221 System

Overview

To help minimize the effects of electromagnetic interference, cables carrying the fast I/O, analog I/O, and field bus communication signals must be shielded.

⚠ WARNING

UNINTENDED EQUIPMENT OPERATION

- Use shielded cables for all fast I/O, analog I/O, and communication signals.
- Ground cable shields for all fast I/O, analog I/O, and communication signals at a single point¹.
- Route communications and I/O cables separately from power cables.

Failure to follow these instructions can result in death, serious injury, or equipment damage.

¹Multipoint grounding is permissible if connections are made to an equipotential ground plane dimensioned to help avoid cable shield damage in the event of power system short-circuit currents.

The use of shielded cables requires compliance with the following wiring rules:

- For protective earth ground connections (PE), metal conduit or ducting can be used for part of the shielding length, provided there is no break in the continuity of the ground connections. For functional earth ground (FE), the shielding is intended to attenuate electromagnetic interference and the shielding must be continuous for the length of the cable. If the purpose is both functional and protective, as is often the case for communication cables, the cable must have continuous shielding.
- Wherever possible, keep cables carrying one type of signal separate from the cables carrying other types of signals or power.

Protective Earth Ground (PE) on the Backplane

The protective earth ground (PE) is connected to the conductive backplane by a heavy-duty wire, usually a braided copper cable with the maximum allowable cable section.

Shielded Cables Connections

Cables carrying the fast I/O, analog I/O, and field bus communication signals must be shielded. The shielding must be securely connected to ground. The fast I/O and analog I/O shields may be connected either to the functional earth ground (FE) or to the protective earth ground (PE) of your M221 Logic Controller. The field bus communication cable shields must be connected to the protective earth ground (PE) with a connecting clamp secured to the conductive backplane of your installation.

The shielding of the Modbus cable must be connected to the protective earth ground (PE).

⚡⚠ DANGER**HAZARD OF ELECTRIC SHOCK**

- The grounding terminal connection (PE) must be used to provide a protective ground at all times.
- Make sure that an appropriate, braided ground cable is attached to the PE/PG ground terminal before connecting or disconnecting the network cable to the equipment.

Failure to follow these instructions will result in death or serious injury.

⚠ WARNING**ACCIDENTAL DISCONNECTION FROM PROTECTIVE GROUND (PE)**

- Do not use the Grounding Bar to provide a protective earth ground (PE).
- Use the Grounding Bar only to provide a functional earth ground (FE).

Failure to follow these instructions can result in death, serious injury, or equipment damage.

Protective Earth Ground (PE) Cable Shielding

To ground the shield of a cable through a grounding clamp:

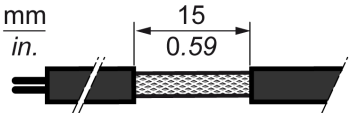
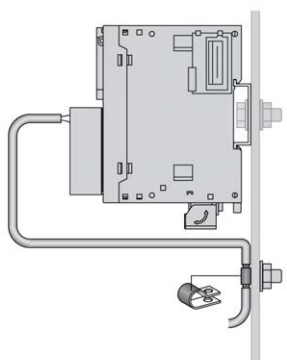
Step	Description	
1	Strip the shielding for a length of 15 mm (0.59 in.).	
2	Attach the cable to the conductive backplane plate by attaching the grounding clamp to the stripped part of the shielding as close as possible to the M221 Logic Controller system base.	

NOTE: The shielding must be clamped securely to the conductive backplane to ensure a good contact.

Functional Earth Ground (FE) Cable Shielding

To connect the shield of a cable through the grounding bar:

Step	Description	
1	Install the grounding bar directly on the conductive backplane below the M221 Logic Controller system as illustrated.	<p>The diagram shows a side view of the M221 Logic Controller system mounted on a backplane. A vertical grounding bar is attached to the bottom of the system. A dimension line indicates a distance of 40 mm (1.57 in.) from the bottom edge of the controller to the top of the grounding bar.</p>
2	Strip the shielding for a length of 15 mm (0.59 in.).	<p>The diagram shows a cross-section of a cable with a braided shield. A section of the shield is shown being stripped back, with a dimension line indicating a length of 15 mm (0.59 in.).</p>
3	Tightly clamp on the blade connector (1) using nylon fastener (2) (width 2.5...3 mm (0.1...0.12 in.)) and appropriate tool.	<p>The diagram shows a top-down view of the blade connector assembly. A blade connector (1) is inserted into the grounding bar. A nylon fastener (2) is used to clamp the blade connector. A dimension line indicates the width of the fastener as 2.5...3 mm (0.1...0.12 in.).</p>

Modicon TM221C Logic Controller

What's in This Part

TM221C16R	89
TM221CE16R	92
TM221C16T	95
TM221CE16T	98
TM221C16U	101
TM221CE16U	104
TM221C24R	107
TM221CE24R	110
TM221C24T	113
TM221CE24T	116
TM221C24U	119
TM221CE24U	122
TM221C40R	125
TM221CE40R	129
TM221C40T	133
TM221CE40T	137
TM221C40U	141
TM221CE40U	144
Embedded I/O Channels	147

TM221C16R

What's in This Chapter

TM221C16R Presentation..... 89

Overview

This chapter describes the TM221C16R logic controller.

TM221C16R Presentation

Overview

The following features are integrated into the TM221C16R logic controller:

- 9 digital inputs
 - 4 fast inputs (HSC)
 - 5 regular inputs
- 7 digital outputs
 - 7 relay outputs
- 2 analog inputs
- Communication ports
 - 1 serial line port
 - 1 USB mini-B programming port

The following figure shows the different components of the logic controllers:

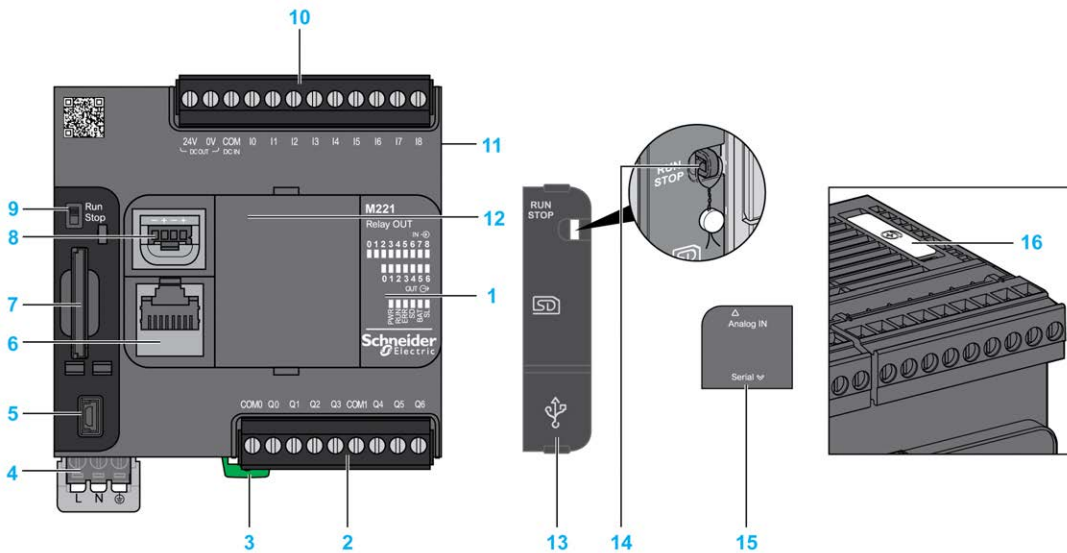

N°	Description	Refer to
1	Status LEDs	—
2	Output removable terminal block	Rules for Removable Screw Terminal Block, page 76
3	Clip-on lock for 35 mm (1.38 in.) top hat section rail (DIN-rail)	DIN Rail
4	100...240 Vac power supply	Power supply, page 84
5	USB mini-B programming port / For terminal connection to a programming PC (EcoStruxure Machine Expert - Basic)	USB mini-B programming port , page 257

N°	Description	Refer to
6	Serial line port 1 / RJ45 connector (RS-232 or RS-485)	Serial line 1, page 260
7	SD Card slot	SD Card Slot, page 55
8	2 analog inputs	Analog Inputs, page 174
9	Run/Stop switch	Run/Stop switch , page 53
10	Input removable terminal block and embedded power supply used for connecting sensors to the inputs. ⁽¹⁾	Rules for Removable Screw Terminal Block, page 76
11	I/O expansion connector	–
12	Cartridge slot	–
13	Protective cover (SD Card slot, Run/Stop switch and USB mini-B programming port)	–
14	Locking hook	–
15	Removable analog inputs cover	–
16	Battery holder	Installing and Replacing the Battery, page 45
<p>(1) Embedded power supply characteristics:</p> <ul style="list-style-type: none"> • Voltage: 24 V -15%...+10% isolated • I_{max}: 250 mA • No protection and no overload detection <p>Refer to Embedded I/O Channels, page 147.</p>		

Status LEDs

The following figure shows the status LEDs:

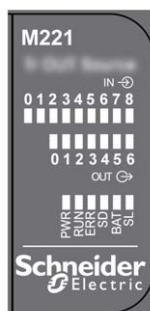

The following table describes the status LEDs:

Label	Function Type	Color	Status	Description		
				Controller States ⁽¹⁾	Prg Port Communication	Application Execution
PWR	Power	Green	On	Indicates that power is applied.		
			Off	Indicates that power is removed.		
RUN	Machine Status	Green	On	Indicates that the controller is running a valid application.		
			Flashing	Indicates that the controller has a valid application that is stopped.		
			Off	Indicates that the controller is not programmed.		
ERR	Error	Red	On*	EXCEPTION	Restricted	NO
			Flashing (with RUN status LED Off)	INTERNAL ERROR	Restricted	NO
			Slow flash	Minor error detected ⁽²⁾	Yes	Depends on the RUN status LED
			1 single flash	No application	Yes	Yes
SD	SD Card Access, page 55	Green	On	Indicates that the SD card is being accessed.		
			Flashing	Indicates that an error was detected during the SD card operation.		
			Off	Indicates no access (idle) or no card is present.		
BAT	Battery, page 44	Red	On	Indicates that the battery needs to be replaced.		
			Flashing	Indicates that the battery charge is low.		
			Off	Indicates that the battery is OK.		
SL	Serial line 1, page 260	Green	On	Indicates the status of Serial line 1.		
			Flashing	Indicates activity on Serial line 1.		
			Off	Indicates no serial communication.		

* ERR LED is also On during booting process.

NOTE: For information about the LEDs integrated into the Ethernet connector, refer to Ethernet Status LEDs, page 260

(1) For more information about the controller state description, refer to the M221 Logic Controller - Programming Guide (see Modicon M221, Logic Controller, Programming Guide).

(2) The controller detected an error but remains in RUNNING state. The ERR LED on the controller flashes. For more information, refer to M221 Logic Controller - Programming Guide.

Dimensions

The following figure show the external dimensions of the logic controller:

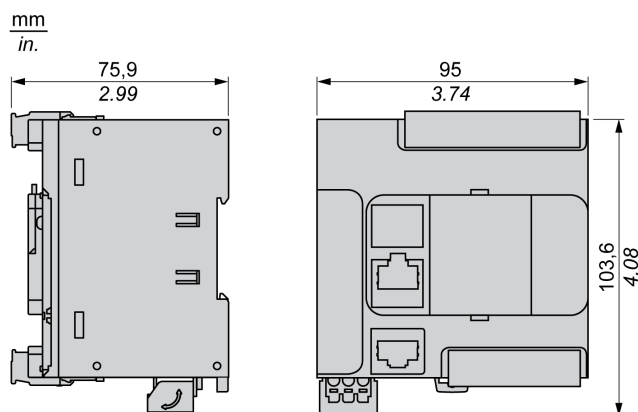

TM221CE16R

What's in This Chapter

TM221CE16R Presentation 92

Overview

This chapter describes the TM221CE16R logic controller.

TM221CE16R Presentation

Overview

The following features are integrated into the TM221CE16R logic controller:

- 9 digital inputs
 - 4 fast inputs (HSC)
 - 5 regular inputs
- 7 digital outputs
 - 7 relay outputs
- 2 analog inputs
- Communication ports
 - 1 serial line port
 - 1 USB mini-B programming port
 - 1 Ethernet port

Description

The following figure shows the different components of the logic controller:

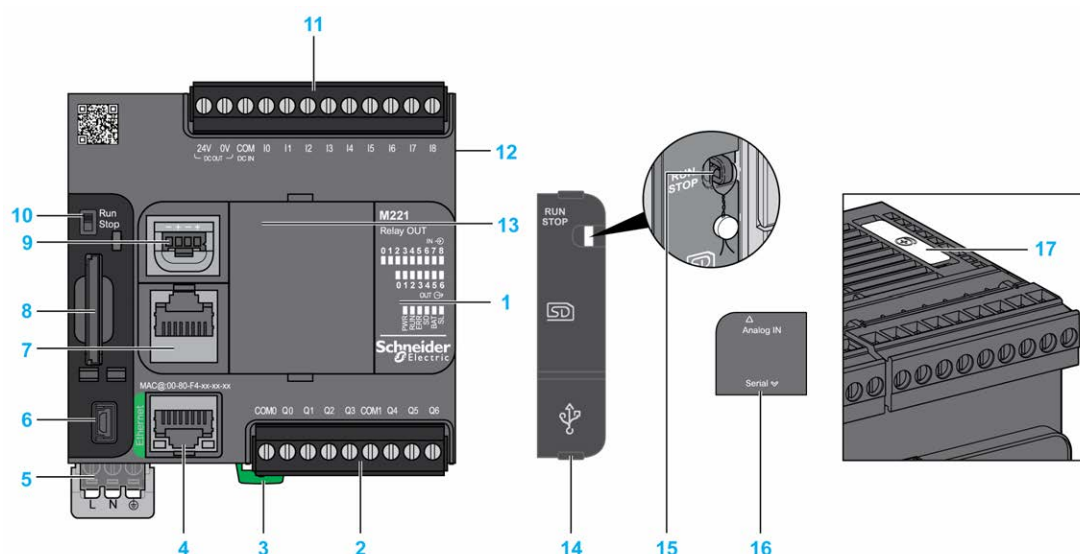

N°	Description	Refer to
1	Status LEDs	–
2	Output removable terminal block	Rules for Removable Screw Terminal Block, page 76

N°	Description	Refer to
3	Clip-on lock for 35 mm (1.38 in.) top hat section rail (DIN-rail)	DIN Rail
4	Ethernet port / RJ45 connector	Ethernet port, page 258
5	100...240 Vac power supply	Power supply, page 84
6	USB mini-B programming port / For terminal connection to a programming PC (EcoStruxure Machine Expert - Basic)	USB mini-B programming port , page 257
7	Serial line port 1 / RJ45 connector (RS-232 or RS-485)	Serial line 1, page 260
8	SD Card slot	SD Card Slot, page 55
9	2 analog inputs	Analog Inputs, page 174
10	Run/Stop switch	Run/Stop switch , page 53
11	Input removable terminal block and embedded power supply used for connecting sensors to the inputs. ⁽¹⁾	Rules for Removable Screw Terminal Block, page 76
12	I/O expansion connector	–
13	Cartridge slot	–
14	Protective cover (SD Card slot, Run/Stop switch and USB mini-B programming port)	–
15	Locking hook	–
16	Removable analog inputs cover	–
17	Battery holder	Installing and Replacing the Battery, page 45
<p>(1) Embedded power supply characteristics:</p> <ul style="list-style-type: none"> • Voltage: 24 V -15%...+10% isolated • I_{max}: 250 mA • No protection and no overload detection <p>Refer to Embedded I/O Channels, page 147.</p>		

Status LEDs

The following figure shows the status LEDs:

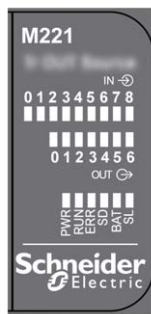

The following table describes the status LEDs:

Label	Function Type	Color	Status	Description		
				Controller States ⁽¹⁾	Prg Port Communication	Application Execution
PWR	Power	Green	On	Indicates that power is applied.		
			Off	Indicates that power is removed.		
RUN	Machine Status	Green	On	Indicates that the controller is running a valid application.		
			Flashing	Indicates that the controller has a valid application that is stopped.		
			Off	Indicates that the controller is not programmed.		

Label	Function Type	Color	Status	Description		
				Controller States ⁽¹⁾	Prg Port Communication	Application Execution
ERR	Error	Red	On*	EXCEPTION	Restricted	NO
			Flashing (with RUN status LED Off)	INTERNAL ERROR	Restricted	NO
			Slow flash	Minor error detected ⁽²⁾	Yes	Depends on the RUN status LED
			1 single flash	No application	Yes	Yes
SD	SD Card Access, page 55	Green	On	Indicates that the SD card is being accessed.		
			Flashing	Indicates that an error was detected during the SD card operation.		
			Off	Indicates no access (idle) or no card is present.		
BAT	Battery, page 44	Red	On	Indicates that the battery needs to be replaced.		
			Flashing	Indicates that the battery charge is low.		
			Off	Indicates that the battery is OK.		
SL	Serial line 1, page 260	Green	On	Indicates the status of Serial line 1.		
			Flashing	Indicates activity on Serial line 1.		
			Off	Indicates no serial communication.		

* ERR LED is also On during booting process.

NOTE: For information about the LEDs integrated into the Ethernet connector, refer to Ethernet Status LEDs, page 260

(1) For more information about the controller state description, refer to the M221 Logic Controller - Programming Guide (see Modicon M221, Logic Controller, Programming Guide).

(2) The controller detected an error but remains in RUNNING state. The ERR LED on the controller flashes. For more information, refer to M221 Logic Controller - Programming Guide.

Dimensions

The following figure shows the external dimensions of the logic controllers:

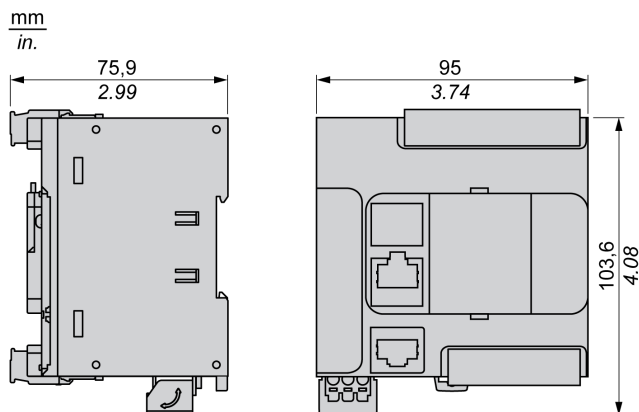

TM221C16T

What's in This Chapter

TM221C16T Presentation 95

Overview

This chapter describes the TM221C16• logic controller.

TM221C16T Presentation

Overview

The following features are integrated into the TM221C16T logic controller:

- 9 digital inputs
 - 4 fast inputs (HSC)
 - 5 regular inputs
- 7 digital outputs
 - 2 fast source transistor outputs
 - 5 regular source transistor outputs
- 2 analog inputs
- Communication ports
 - 1 serial line port
 - 1 USB mini-B programming port

Description

The following figure shows the different components of the logic controllers:

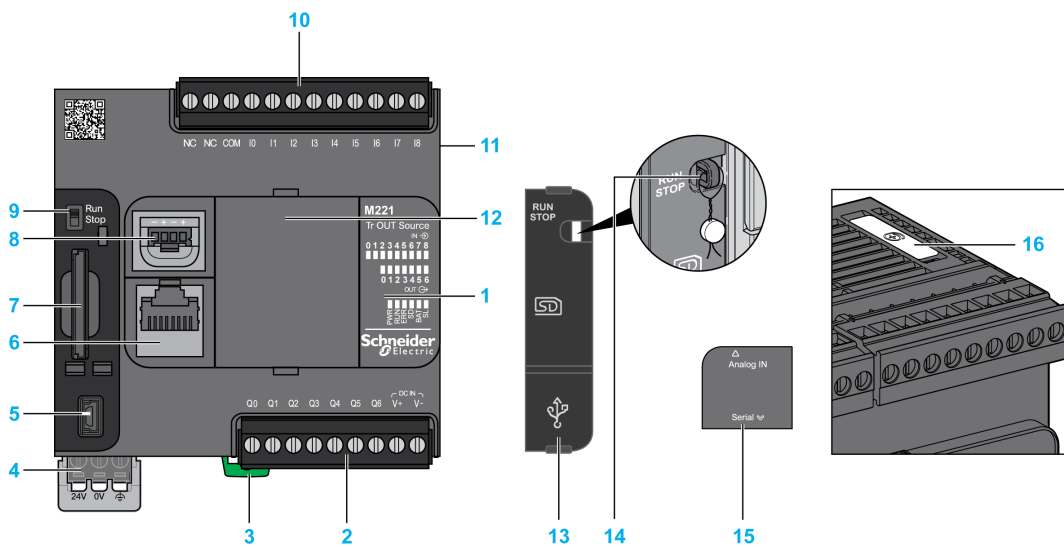

N°	Description	Refer to
1	Status LEDs	—
2	Output removable terminal block	Rules for Removable Screw Terminal Block, page 76

N°	Description	Refer to
3	Clip-on lock for 35 mm (1.38 in.) top hat section rail (DIN-rail)	DIN Rail
4	24 Vdc power supply	Power supply, page 79
5	USB mini-B programming port / For terminal connection to a programming PC (EcoStruxure Machine Expert - Basic)	USB mini-B programming port , page 257
6	Serial line port 1 / RJ45 connector (RS-232 or RS-485)	Serial line 1, page 260
7	SD Card slot	SD Card Slot, page 55
8	2 analog inputs	Analog Inputs, page 174
9	Run/Stop switch	Run/Stop switch , page 53
10	Input removable terminal block	Rules for Removable Screw Terminal Block, page 76
11	I/O expansion connector	–
12	Cartridge slot	–
13	Protective cover (SD Card slot, Run/Stop switch and USB mini-B programming port)	–
14	Locking hook	–
15	Removable analog inputs cover	–
16	Battery holder	Installing and Replacing the Battery, page 45

Status LEDs

The following figure shows the status LEDs:

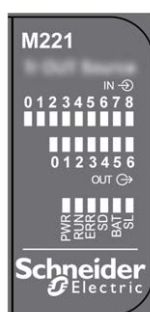

The following table describes the status LEDs:

Label	Function Type	Color	Status	Description		
				Controller States ⁽¹⁾	Prg Port Communication	Application Execution
PWR	Power	Green	On	Indicates that power is applied.		
			Off	Indicates that power is removed.		
RUN	Machine Status	Green	On	Indicates that the controller is running a valid application.		
			Flashing	Indicates that the controller has a valid application that is stopped.		
			Off	Indicates that the controller is not programmed.		
ERR	Error	Red	On*	EXCEPTION	Restricted	NO
			Flashing (with RUN status LED Off)	INTERNAL ERROR	Restricted	NO
			Slow flash	Minor error detected ⁽²⁾	Yes	Depends on the RUN status LED
			1 single flash	No application	Yes	Yes

Label	Function Type	Color	Status	Description		
				Controller States ⁽¹⁾	Prg Port Communication	Application Execution
SD	SD Card Access, page 55	Green	On	Indicates that the SD card is being accessed.		
			Flashing	Indicates that an error was detected during the SD card operation.		
			Off	Indicates no access (idle) or no card is present.		
BAT	Battery, page 44	Red	On	Indicates that the battery needs to be replaced.		
			Flashing	Indicates that the battery charge is low.		
			Off	Indicates that the battery is OK.		
SL	Serial line 1, page 260	Green	On	Indicates the status of Serial line 1.		
			Flashing	Indicates activity on Serial line 1.		
			Off	Indicates no serial communication.		

* ERR LED is also On during booting process.

NOTE: For information about the LEDs integrated into the Ethernet connector, refer to Ethernet Status LEDs, page 260

(1) For more information about the controller state description, refer to the M221 Logic Controller - Programming Guide (see Modicon M221, Logic Controller, Programming Guide).

(2) The controller detected an error but remains in RUNNING state. The ERR LED on the controller flashes. For more information, refer to M221 Logic Controller - Programming Guide.

Dimensions

The following figure shows the external dimensions of the logic controllers:

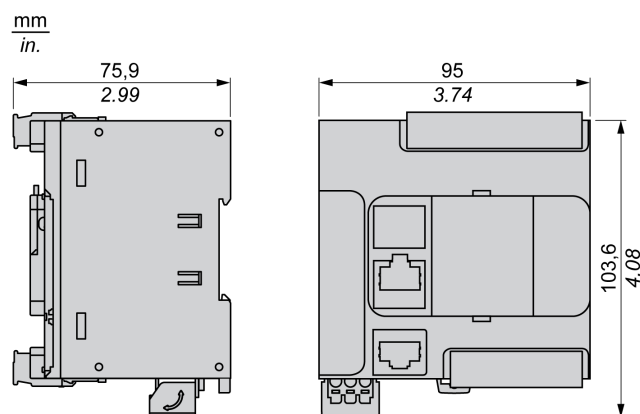

TM221CE16T

What's in This Chapter

TM221CE16T Presentation..... 98

Overview

This chapter describes the TM221CE16T logic controller.

TM221CE16T Presentation

Overview

The following features are integrated into the TM221CE16T logic controller:

- 9 digital inputs
 - 4 fast inputs (HSC)
 - 5 regular inputs
- 7 digital outputs
 - 2 fast source transistor outputs
 - 5 regular source transistor outputs
- 2 analog inputs
- Communication ports
 - 1 serial line port
 - 1 USB mini-B programming port
 - 1 Ethernet port

Description

The following figure shows the different components of the logic controllers:

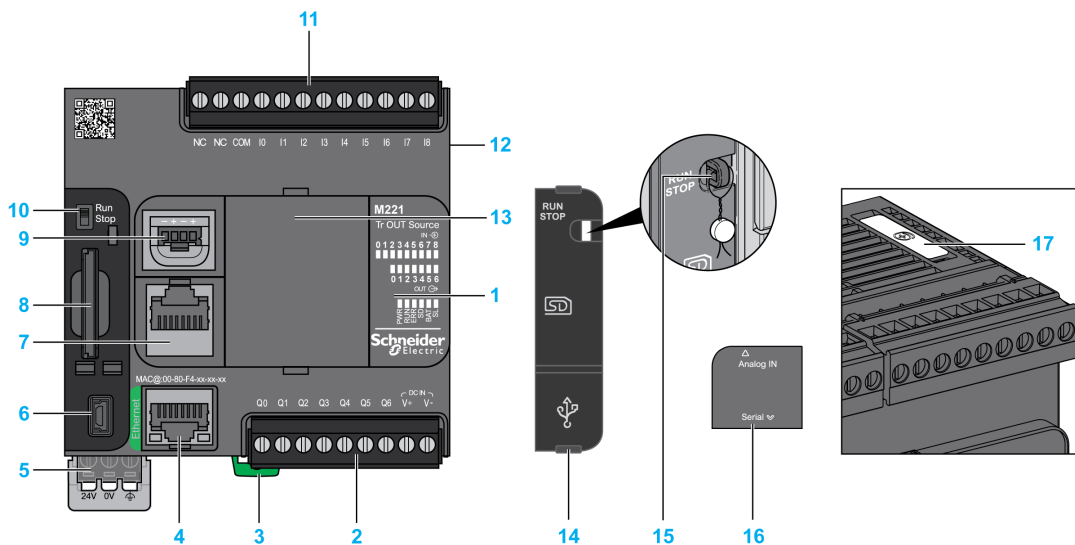

N°	Description	Refer to
1	Status LEDs	–
2	Output removable terminal block	Rules for Removable Screw Terminal Block, page 76
3	Clip-on lock for 35 mm (1.38 in.) top hat section rail (DIN-rail)	DIN Rail
4	Ethernet port / RJ45 connector	Ethernet port, page 258
5	24 Vdc power supply	Power supply, page 79
6	USB mini-B programming port / For terminal connection to a programming PC (EcoStruxure Machine Expert - Basic)	USB mini-B programming port , page 257
7	Serial line port 1 / RJ45 connector (RS-232 or RS-485)	Serial line 1, page 260
8	SD Card slot	SD Card Slot, page 55
9	2 analog inputs	Analog Inputs, page 174
10	Run/Stop switch	Run/Stop switch , page 53
11	Input removable terminal block	Rules for Removable Screw Terminal Block, page 76
12	I/O expansion connector	–
13	Cartridge slot	–
14	Protective cover (SD Card slot, Run/Stop switch and USB mini-B programming port)	–
15	Locking hook	–
16	Removable analog inputs cover	–
17	Battery holder	Installing and Replacing the Battery, page 45

Status LEDs

The following figure shows the status LEDs:

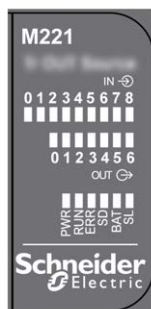

The following table describes the status LEDs:

Label	Function Type	Color	Status	Description		
				Controller States ⁽¹⁾	Prg Port Communication	Application Execution
PWR	Power	Green	On	Indicates that power is applied.		
			Off	Indicates that power is removed.		
RUN	Machine Status	Green	On	Indicates that the controller is running a valid application.		
			Flashing	Indicates that the controller has a valid application that is stopped.		
			Off	Indicates that the controller is not programmed.		

Label	Function Type	Color	Status	Description		
				Controller States ⁽¹⁾	Prg Port Communication	Application Execution
ERR	Error	Red	On*	EXCEPTION	Restricted	NO
			Flashing (with RUN status LED Off)	INTERNAL ERROR	Restricted	NO
			Slow flash	Minor error detected ⁽²⁾	Yes	Depends on the RUN status LED
			1 single flash	No application	Yes	Yes
SD	SD Card Access, page 55	Green	On	Indicates that the SD card is being accessed.		
			Flashing	Indicates that an error was detected during the SD card operation.		
			Off	Indicates no access (idle) or no card is present.		
BAT	Battery, page 44	Red	On	Indicates that the battery needs to be replaced.		
			Flashing	Indicates that the battery charge is low.		
			Off	Indicates that the battery is OK.		
SL	Serial line 1, page 260	Green	On	Indicates the status of Serial line 1.		
			Flashing	Indicates activity on Serial line 1.		
			Off	Indicates no serial communication.		

* ERR LED is also On during booting process.

NOTE: For information about the LEDs integrated into the Ethernet connector, refer to Ethernet Status LEDs, page 260

(1) For more information about the controller state description, refer to the M221 Logic Controller - Programming Guide (see Modicon M221, Logic Controller, Programming Guide).

(2) The controller detected an error but remains in RUNNING state. The ERR LED on the controller flashes. For more information, refer to M221 Logic Controller - Programming Guide.

Dimensions

The following figure shows the external dimensions of the logic controllers:

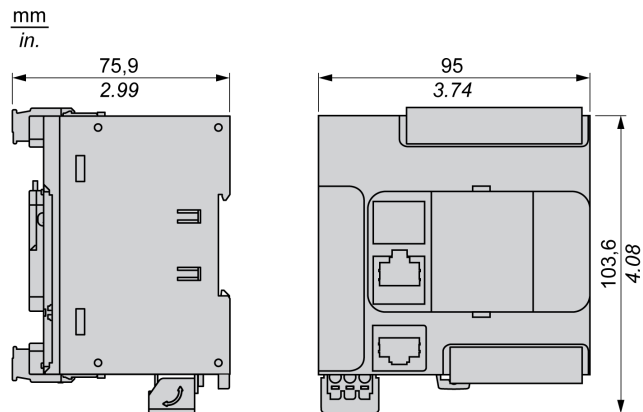

TM221C16U

What's in This Chapter

TM221C16U Presentation..... 101

Overview

This chapter describes the TM221C16• logic controller.

TM221C16U Presentation

Overview

The following features are integrated into the TM221C16U logic controller:

- 9 digital inputs
 - 4 fast inputs (HSC)
 - 5 regular inputs
- 7 digital outputs
 - 2 fast sink transistor outputs
 - 5 regular sink transistor outputs
- 2 analog inputs
- Communication ports
 - 1 serial line port
 - 1 USB mini-B programming port

Description

The following figure shows the different components of the logic controllers:

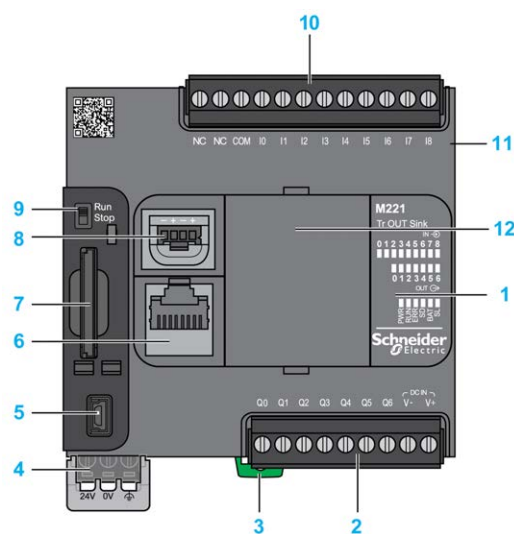

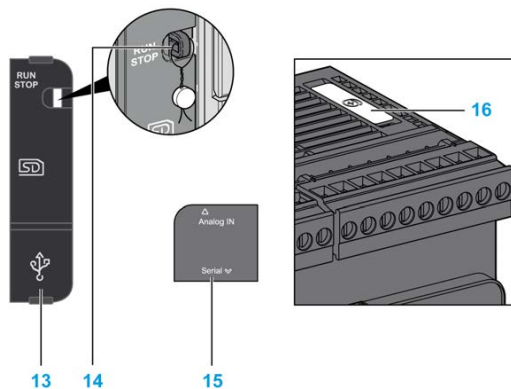

N°	Description	Refer to
1	Status LEDs	–
2	Output removable terminal block	Rules for Removable Screw Terminal Block, page 76
3	Clip-on lock for 35 mm (1.38 in.) top hat section rail (DIN-rail)	DIN Rail
4	24 Vdc power supply	Power supply, page 79
5	USB mini-B programming port / For terminal connection to a programming PC (EcoStruxure Machine Expert - Basic)	USB mini-B programming port , page 257
6	Serial line port 1 / RJ45 connector (RS-232 or RS-485)	Serial line 1, page 260
7	SD Card slot	SD Card Slot, page 55
8	2 analog inputs	Analog Inputs, page 174
9	Run/Stop switch	Run/Stop switch , page 53
10	Input removable terminal block	Rules for Removable Screw Terminal Block, page 76
11	I/O expansion connector	–
12	Cartridge slot	–
13	Protective cover (SD Card slot, Run/Stop switch and USB mini-B programming port)	–
14	Locking hook	–
15	Removable analog inputs cover	–
16	Battery holder	Installing and Replacing the Battery, page 45

Status LEDs

The following figure shows the status LEDs:

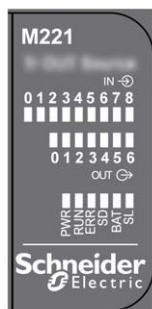

The following table describes the status LEDs:

Label	Function Type	Color	Status	Description		
				Controller States ⁽¹⁾	Prg Port Communication	Application Execution
PWR	Power	Green	On	Indicates that power is applied.		
			Off	Indicates that power is removed.		
RUN	Machine Status	Green	On	Indicates that the controller is running a valid application.		
			Flashing	Indicates that the controller has a valid application that is stopped.		
			Off	Indicates that the controller is not programmed.		
ERR	Error	Red	On*	EXCEPTION	Restricted	NO
			Flashing (with RUN status LED Off)	INTERNAL ERROR	Restricted	NO
			Slow flash	Minor error detected ⁽²⁾	Yes	Depends on the RUN status LED
			1 single flash	No application	Yes	Yes
SD	SD Card Access, page 55	Green	On	Indicates that the SD card is being accessed.		
			Flashing	Indicates that an error was detected during the SD card operation.		
			Off	Indicates no access (idle) or no card is present.		
BAT	Battery, page 44	Red	On	Indicates that the battery needs to be replaced.		
			Flashing	Indicates that the battery charge is low.		
			Off	Indicates that the battery is OK.		
SL	Serial line 1, page 260	Green	On	Indicates the status of Serial line 1.		
			Flashing	Indicates activity on Serial line 1.		
			Off	Indicates no serial communication.		

* ERR LED is also On during booting process.

NOTE: For information about the LEDs integrated into the Ethernet connector, refer to Ethernet Status LEDs, page 260

(1) For more information about the controller state description, refer to the M221 Logic Controller - Programming Guide (see Modicon M221, Logic Controller, Programming Guide).

(2) The controller detected an error but remains in RUNNING state. The ERR LED on the controller flashes. For more information, refer to M221 Logic Controller - Programming Guide.

Dimensions

The following figure shows the external dimensions of the logic controllers:

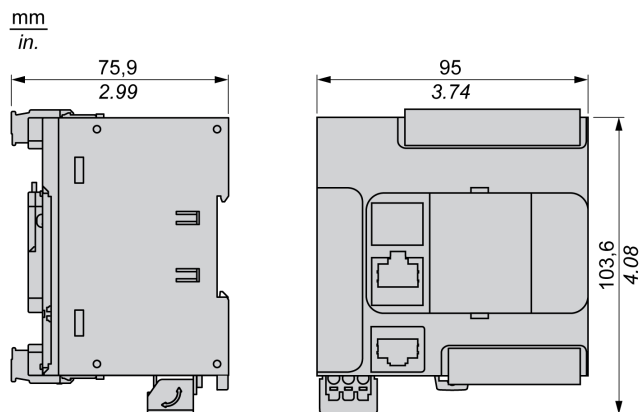

TM221CE16U

What's in This Chapter

TM221CE16U Presentation	104
-------------------------------	-----

Overview

This chapter describes the TM221CE16U logic controller.

TM221CE16U Presentation

Overview

The following features are integrated into the TM221CE16U logic controller:

- 9 digital inputs
 - 4 fast inputs (HSC)
 - 5 regular inputs
- 7 digital outputs
 - 2 fast sink transistor outputs
 - 5 regular sink transistor outputs
- 2 analog inputs
- Communication ports
 - 1 serial line port
 - 1 USB mini-B programming port
 - 1 Ethernet port

Description

The following figure shows the different components of the logic controllers:

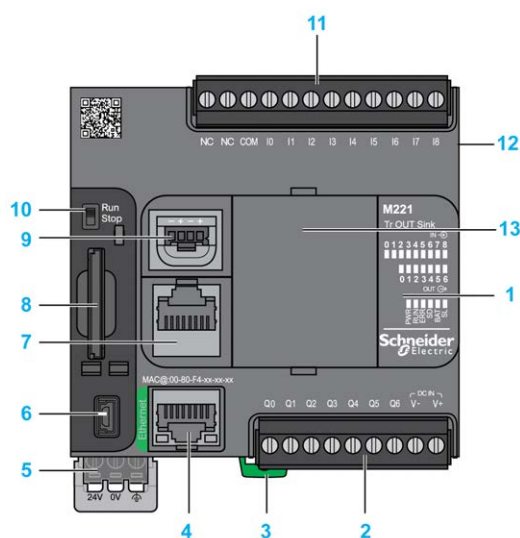

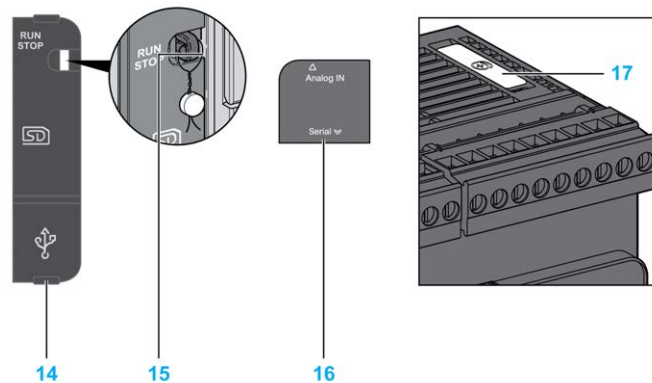

N°	Description	Refer to
1	Status LEDs	–
2	Output removable terminal block	Rules for Removable Screw Terminal Block, page 76
3	Clip-on lock for 35 mm (1.38 in.) top hat section rail (DIN-rail)	DIN Rail
4	Ethernet port / RJ45 connector	Ethernet port, page 258
5	24 Vdc power supply	Power supply, page 79
6	USB mini-B programming port / For terminal connection to a programming PC (EcoStruxure Machine Expert - Basic)	USB mini-B programming port , page 257
7	Serial line port 1 / RJ45 connector (RS-232 or RS-485)	Serial line 1, page 260
8	SD Card slot	SD Card Slot, page 55
9	2 analog inputs	Analog Inputs, page 174
10	Run/Stop switch	Run/Stop switch , page 53
11	Input removable terminal block	Rules for Removable Screw Terminal Block, page 76
12	I/O expansion connector	–
13	Cartridge slot	–
14	Protective cover (SD Card slot, Run/Stop switch and USB mini-B programming port)	–
15	Locking hook	–
16	Removable analog inputs cover	–
17	Battery holder	Installing and Replacing the Battery, page 45

Status LEDs

The following figure shows the status LEDs:

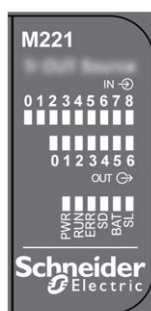

The following table describes the status LEDs:

Label	Function Type	Color	Status	Description		
				Controller States ⁽¹⁾	Prg Port Communication	Application Execution
PWR	Power	Green	On	Indicates that power is applied.		
			Off	Indicates that power is removed.		
RUN	Machine Status	Green	On	Indicates that the controller is running a valid application.		
			Flashing	Indicates that the controller has a valid application that is stopped.		
			Off	Indicates that the controller is not programmed.		
ERR	Error	Red	On*	EXCEPTION	Restricted	NO
			Flashing (with RUN status LED Off)	INTERNAL ERROR	Restricted	NO
			Slow flash	Minor error detected ⁽²⁾	Yes	Depends on the RUN status LED
			1 single flash	No application	Yes	Yes
SD	SD Card Access, page 55	Green	On	Indicates that the SD card is being accessed.		
			Flashing	Indicates that an error was detected during the SD card operation.		
			Off	Indicates no access (idle) or no card is present.		
BAT	Battery, page 44	Red	On	Indicates that the battery needs to be replaced.		
			Flashing	Indicates that the battery charge is low.		
			Off	Indicates that the battery is OK.		
SL	Serial line 1, page 260	Green	On	Indicates the status of Serial line 1.		
			Flashing	Indicates activity on Serial line 1.		
			Off	Indicates no serial communication.		

* ERR LED is also On during booting process.

NOTE: For information about the LEDs integrated into the Ethernet connector, refer to Ethernet Status LEDs, page 260

(1) For more information about the controller state description, refer to the M221 Logic Controller - Programming Guide (see Modicon M221, Logic Controller, Programming Guide).

(2) The controller detected an error but remains in RUNNING state. The ERR LED on the controller flashes. For more information, refer to M221 Logic Controller - Programming Guide.

Dimensions

The following figure shows the external dimensions of the logic controllers:

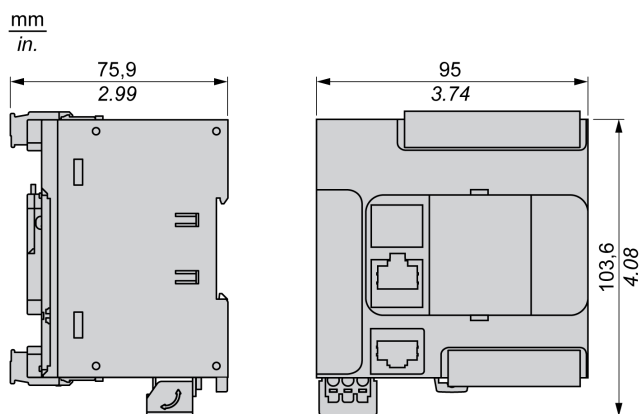

TM221C24R

What's in This Chapter

TM221C24R Presentation..... 107

Overview

This chapter describes the TM221C24R logic controller.

TM221C24R Presentation

Overview

The following features are integrated into the TM221C24R logic controller:

- 14 digital inputs
 - 4 fast inputs (HSC)
 - 10 regular inputs
- 10 digital outputs
 - 10 relay outputs
- 2 analog inputs
- Communication ports
 - 1 serial line port
 - 1 USB mini-B programming port

Description

The following figure shows the different components of the logic controller:

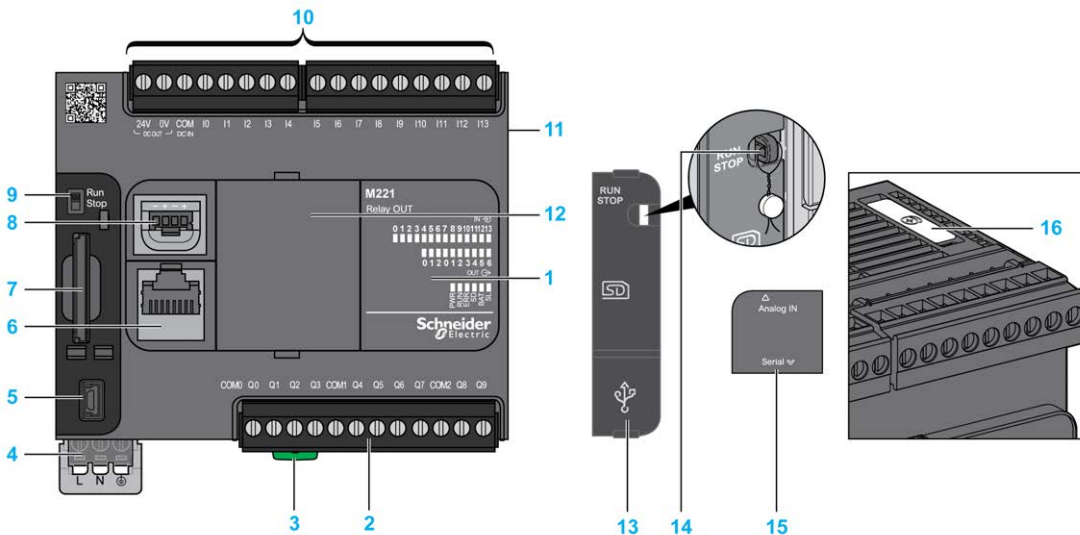

N°	Description	Refer to
1	Status LEDs	–
2	Output removable terminal block	Rules for Removable Screw Terminal Block, page 76
3	Clip-on lock for 35 mm (1.38 in.) top hat section rail (DIN-rail)	DIN Rail

N°	Description	Refer to
4	100...240 Vac power supply	Power supply, page 84
5	USB mini-B programming port / For terminal connection to a programming PC (EcoStruxure Machine Expert - Basic)	USB mini-B programming port , page 257
6	Serial line port 1 / RJ45 connector (RS-232 or RS-485)	Serial line 1, page 260
7	SD Card slot	SD Card Slot, page 55
8	2 analog inputs	Analog Inputs, page 174
9	Run/Stop switch	Run/Stop switch , page 53
10	Input removable terminal block and embedded power supply used for connecting sensors to the inputs. (1)	Rules for Removable Screw Terminal Block, page 76
11	I/O expansion connector	-
12	Cartridge slot	-
13	Protective cover (SD Card slot, Run/Stop switch and USB mini-B programming port)	-
14	Locking hook	-
15	Removable analog inputs cover	-
16	Battery holder	Installing and Replacing the Battery, page 45

(1) Embedded power supply characteristics:

- Voltage: 24 V -15%...+10% isolated
- I_{max}: 250 mA
- No protection and no overload detection

Refer to Embedded I/O Channels, page 147.

Status LEDs

The following figure shows the status LEDs:



The following table describes the status LEDs:

Label	Function Type	Color	Status	Description		
				Controller States ⁽¹⁾	Prg Port Communication	Application Execution
PWR	Power	Green	On	Indicates that power is applied.		
			Off	Indicates that power is removed.		
RUN	Machine Status	Green	On	Indicates that the controller is running a valid application.		
			Flashing	Indicates that the controller has a valid application that is stopped.		
			Off	Indicates that the controller is not programmed.		

Label	Function Type	Color	Status	Description		
				Controller States ⁽¹⁾	Prg Port Communication	Application Execution
ERR	Error	Red	On*	EXCEPTION	Restricted	NO
			Flashing (with RUN status LED Off)	INTERNAL ERROR	Restricted	NO
			Slow flash	Minor error detected ⁽²⁾	Yes	Depends on the RUN status LED
			1 single flash	No application	Yes	Yes
SD	SD Card Access, page 55	Green	On	Indicates that the SD card is being accessed.		
			Flashing	Indicates that an error was detected during the SD card operation.		
			Off	Indicates no access (idle) or no card is present.		
BAT	Battery, page 44	Red	On	Indicates that the battery needs to be replaced.		
			Flashing	Indicates that the battery charge is low.		
			Off	Indicates that the battery is OK.		
SL	Serial line 1, page 260	Green	On	Indicates the status of Serial line 1.		
			Flashing	Indicates activity on Serial line 1.		
			Off	Indicates no serial communication.		

* ERR LED is also On during booting process.

NOTE: For information about the LEDs integrated into the Ethernet connector, refer to Ethernet Status LEDs, page 260

(1) For more information about the controller state description, refer to the M221 Logic Controller - Programming Guide (see Modicon M221, Logic Controller, Programming Guide).

(2) The controller detected an error but remains in RUNNING state. The ERR LED on the controller flashes. For more information, refer to M221 Logic Controller - Programming Guide.

Dimensions

The following figure shows the external dimensions of the logic controllers:

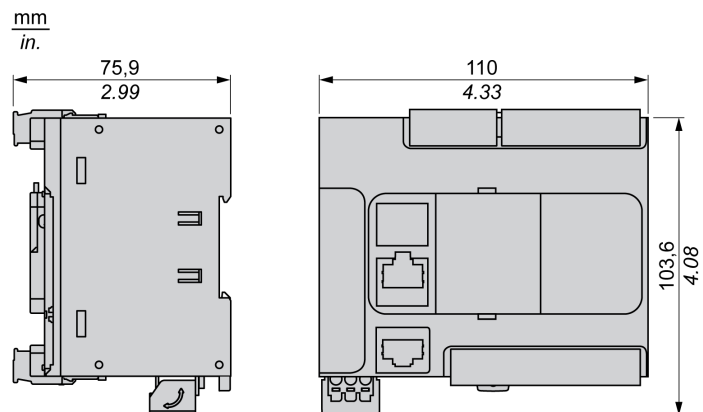

TM221CE24R

What's in This Chapter

TM221CE24R Presentation 110

Overview

This chapter describes the TM221CE24R logic controller.

TM221CE24R Presentation

Overview

The following features are integrated into the TM221CE24R logic controller:

- 14 digital inputs
 - 4 fast inputs (HSC)
 - 10 regular inputs
- 10 digital outputs
 - 10 relay outputs
- 2 analog inputs
- Communication ports
 - 1 serial line port
 - 1 USB mini-B programming port
 - 1 Ethernet port

Description

The following figure shows the different components of the logic controllers:

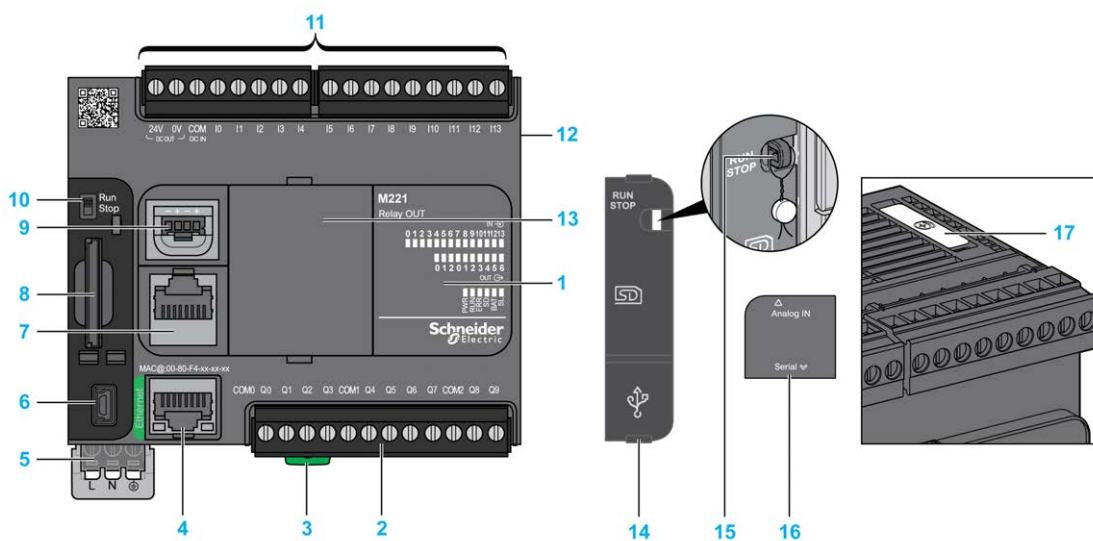

N°	Description	Refer to
1	Status LEDs	–
2	Output removable terminal block	Rules for Removable Screw Terminal Block, page 76

N°	Description	Refer to
3	Clip-on lock for 35 mm (1.38 in.) top hat section rail (DIN-rail)	DIN Rail
4	Ethernet port / RJ45 connector	Ethernet port, page 258
5	100...240 Vac power supply	Power supply, page 84
6	USB mini-B programming port / For terminal connection to a programming PC (EcoStruxure Machine Expert - Basic)	USB mini-B programming port , page 257
7	Serial line port 1 / RJ45 connector (RS-232 or RS-485)	Serial line 1, page 260
8	SD Card slot	SD Card Slot, page 55
9	2 analog inputs	Analog Inputs, page 174
10	Run/Stop switch	Run/Stop switch , page 53
11	Input removable terminal block and embedded power supply used for connecting sensors to the inputs. ⁽¹⁾	Rules for Removable Screw Terminal Block, page 76
12	I/O expansion connector	–
13	Cartridge slot	–
14	Protective cover (SD Card slot, Run/Stop switch and USB mini-B programming port)	–
15	Locking hook	–
16	Removable analog inputs cover	–
17	Battery holder	Installing and Replacing the Battery, page 45

(1) Embedded power supply characteristics:

- Voltage: 24 V -15%...+10% isolated
- I_{max}: 250 mA
- No protection and no overload detection

Refer to Embedded I/O Channels, page 147.

Status LEDs

The following figure shows the status LEDs:



The following table describes the status LEDs:

Label	Function Type	Color	Status	Description		
				Controller States ⁽¹⁾	Prg Port Communication	Application Execution
PWR	Power	Green	On	Indicates that power is applied.		
			Off	Indicates that power is removed.		
RUN	Machine Status	Green	On	Indicates that the controller is running a valid application.		
			Flashing	Indicates that the controller has a valid application that is stopped.		
			Off	Indicates that the controller is not programmed.		

Label	Function Type	Color	Status	Description		
				Controller States ⁽¹⁾	Prg Port Communication	Application Execution
ERR	Error	Red	On*	EXCEPTION	Restricted	NO
			Flashing (with RUN status LED Off)	INTERNAL ERROR	Restricted	NO
			Slow flash	Minor error detected ⁽²⁾	Yes	Depends on the RUN status LED
			1 single flash	No application	Yes	Yes
SD	SD Card Access, page 55	Green	On	Indicates that the SD card is being accessed.		
			Flashing	Indicates that an error was detected during the SD card operation.		
			Off	Indicates no access (idle) or no card is present.		
BAT	Battery, page 44	Red	On	Indicates that the battery needs to be replaced.		
			Flashing	Indicates that the battery charge is low.		
			Off	Indicates that the battery is OK.		
SL	Serial line 1, page 260	Green	On	Indicates the status of Serial line 1.		
			Flashing	Indicates activity on Serial line 1.		
			Off	Indicates no serial communication.		

* ERR LED is also On during booting process.

NOTE: For information about the LEDs integrated into the Ethernet connector, refer to Ethernet Status LEDs, page 260

(1) For more information about the controller state description, refer to the M221 Logic Controller - Programming Guide (see Modicon M221, Logic Controller, Programming Guide).

(2) The controller detected an error but remains in RUNNING state. The ERR LED on the controller flashes. For more information, refer to M221 Logic Controller - Programming Guide.

Dimensions

The following figure shows the external dimensions of the logic controllers:

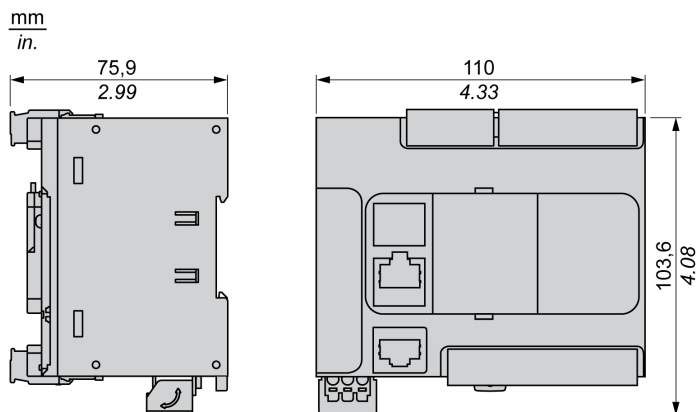

TM221C24T

What's in This Chapter

TM221C24T Presentation 113

Overview

This chapter describes the TM221C24T logic controller.

TM221C24T Presentation

Overview

The following features are integrated into the TM221C24T logic controller:

- 14 digital inputs
 - 4 fast inputs (HSC)
 - 10 regular inputs
- 10 digital outputs
 - 2 fast source transistor outputs
 - 8 regular source transistor outputs
- 2 analog inputs
- Communication ports
 - 1 serial line port
 - 1 USB mini-B programming port

Description

The following figure shows the different components of the logic controllers:

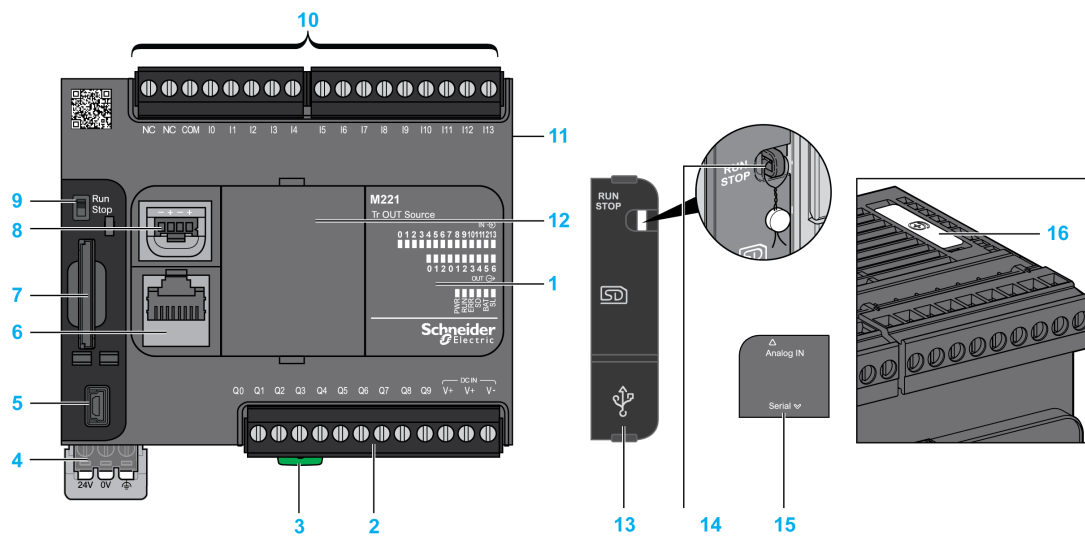

N°	Description	Refer to
1	Status LEDs	—
2	Output removable terminal block	Rules for Removable Screw Terminal Block, page 76

N°	Description	Refer to
3	Clip-on lock for 35 mm (1.38 in.) top hat section rail (DIN-rail)	DIN Rail
4	24 Vdc power supply	Power supply, page 79
5	USB mini-B programming port / For terminal connection to a programming PC (EcoStruxure Machine Expert - Basic)	USB mini-B programming port , page 257
6	Serial line port 1 / RJ45 connector (RS-232 or RS-485)	Serial line 1, page 260
7	SD Card slot	SD Card Slot, page 55
8	2 analog inputs	Analog Inputs, page 174
9	Run/Stop switch	Run/Stop switch , page 53
10	Input removable terminal block	Rules for Removable Screw Terminal Block, page 76
11	I/O expansion connector	–
12	Cartridge slot	–
13	Protective cover (SD Card slot, Run/Stop switch and USB mini-B programming port)	–
14	Locking hook	–
15	Removable analog inputs cover	–
16	Battery holder	Installing and Replacing the Battery, page 45

Status LEDs

The following figure shows the status LEDs:



The following table describes the status LEDs:

Label	Function Type	Color	Status	Description		
				Controller States ⁽¹⁾	Prg Port Communication	Application Execution
PWR	Power	Green	On	Indicates that power is applied.		
			Off	Indicates that power is removed.		
RUN	Machine Status	Green	On	Indicates that the controller is running a valid application.		
			Flashing	Indicates that the controller has a valid application that is stopped.		
			Off	Indicates that the controller is not programmed.		
ERR	Error	Red	On*	EXCEPTION	Restricted	NO
			Flashing (with RUN status LED Off)	INTERNAL ERROR	Restricted	NO
			Slow flash	Minor error detected ⁽²⁾	Yes	Depends on the RUN status LED
			1 single flash	No application	Yes	Yes

Label	Function Type	Color	Status	Description		
				Controller States ⁽¹⁾	Prg Port Communication	Application Execution
SD	SD Card Access, page 55	Green	On	Indicates that the SD card is being accessed.		
			Flashing	Indicates that an error was detected during the SD card operation.		
			Off	Indicates no access (idle) or no card is present.		
BAT	Battery, page 44	Red	On	Indicates that the battery needs to be replaced.		
			Flashing	Indicates that the battery charge is low.		
			Off	Indicates that the battery is OK.		
SL	Serial line 1, page 260	Green	On	Indicates the status of Serial line 1.		
			Flashing	Indicates activity on Serial line 1.		
			Off	Indicates no serial communication.		

* ERR LED is also On during booting process.

NOTE: For information about the LEDs integrated into the Ethernet connector, refer to Ethernet Status LEDs, page 260

(1) For more information about the controller state description, refer to the M221 Logic Controller - Programming Guide (see Modicon M221, Logic Controller, Programming Guide).

(2) The controller detected an error but remains in RUNNING state. The ERR LED on the controller flashes. For more information, refer to M221 Logic Controller - Programming Guide.

Dimensions

The following figure shows the external dimensions of the logic controllers:

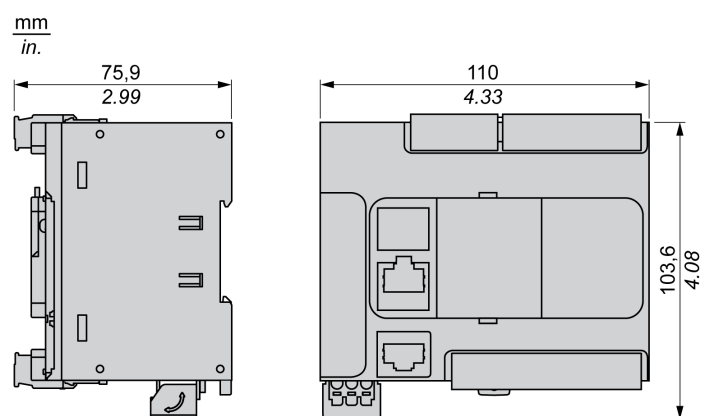

TM221CE24T

What's in This Chapter

TM221CE24T Presentation..... 116

Overview

This chapter describes the TM221CE24T logic controller.

TM221CE24T Presentation

Overview

The following features are integrated into the TM221CE24T logic controller:

- 14 digital inputs
 - 4 fast inputs (HSC)
 - 10 regular inputs
- 10 digital outputs
 - 2 fast source transistor outputs
 - 8 regular source transistor outputs
- 2 analog inputs
- Communication ports
 - 1 serial line port
 - 1 USB mini-B programming port
 - 1 Ethernet port

Description

The following figure shows the different components of the logic controllers:

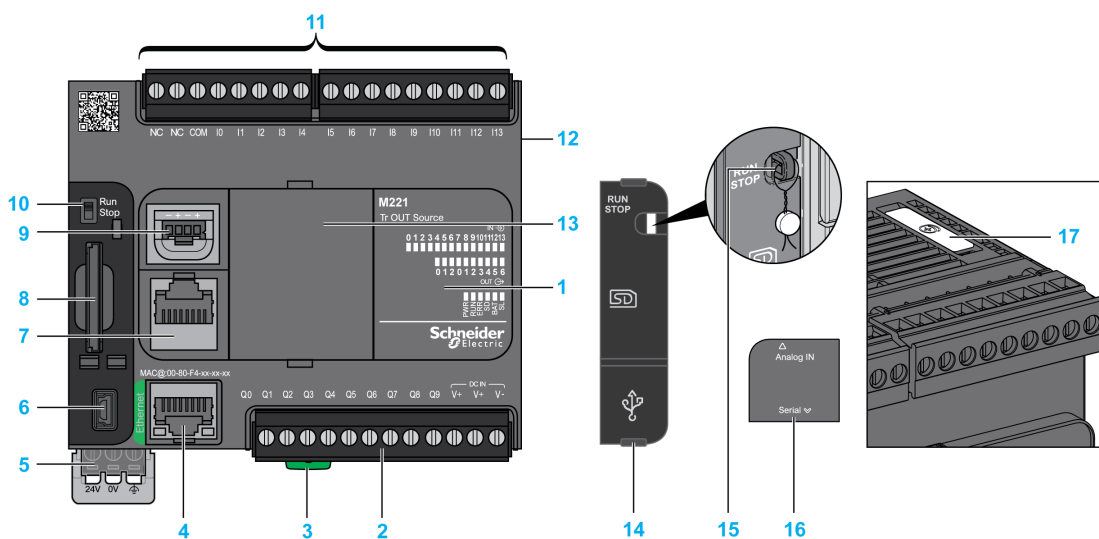

N°	Description	Refer to
1	Status LEDs	–
2	Output removable terminal block	Rules for Removable Screw Terminal Block, page 76
3	Clip-on lock for 35 mm (1.38 in.) top hat section rail (DIN-rail)	DIN Rail
4	Ethernet port / RJ45 connector	Ethernet port, page 258
5	24 Vdc power supply	Power supply, page 79
6	USB mini-B programming port / For terminal connection to a programming PC (EcoStruxure Machine Expert - Basic)	USB mini-B programming port , page 257
7	Serial line port 1 / RJ45 connector (RS-232 or RS-485)	Serial line 1, page 260
8	SD Card slot	SD Card Slot, page 55
9	2 analog inputs	Analog Inputs, page 174
10	Run/Stop switch	Run/Stop switch , page 53
11	Input removable terminal block	Rules for Removable Screw Terminal Block, page 76
12	I/O expansion connector	–
13	Cartridge slot	–
14	Protective cover (SD Card slot, Run/Stop switch and USB mini-B programming port)	–
15	Locking hook	–
16	Removable analog inputs cover	–
17	Battery holder	Installing and Replacing the Battery, page 45

Status LEDs

The following figure shows the status LEDs:



The following table describes the status LEDs:

Label	Function Type	Color	Status	Description		
				Controller States ⁽¹⁾	Prg Port Communication	Application Execution
PWR	Power	Green	On	Indicates that power is applied.		
			Off	Indicates that power is removed.		
RUN	Machine Status	Green	On	Indicates that the controller is running a valid application.		
			Flashing	Indicates that the controller has a valid application that is stopped.		
			Off	Indicates that the controller is not programmed.		

Label	Function Type	Color	Status	Description		
				Controller States ⁽¹⁾	Prg Port Communication	Application Execution
ERR	Error	Red	On*	EXCEPTION	Restricted	NO
			Flashing (with RUN status LED Off)	INTERNAL ERROR	Restricted	NO
			Slow flash	Minor error detected ⁽²⁾	Yes	Depends on the RUN status LED
			1 single flash	No application	Yes	Yes
SD	SD Card Access, page 55	Green	On	Indicates that the SD card is being accessed.		
			Flashing	Indicates that an error was detected during the SD card operation.		
			Off	Indicates no access (idle) or no card is present.		
BAT	Battery, page 44	Red	On	Indicates that the battery needs to be replaced.		
			Flashing	Indicates that the battery charge is low.		
			Off	Indicates that the battery is OK.		
SL	Serial line 1, page 260	Green	On	Indicates the status of Serial line 1.		
			Flashing	Indicates activity on Serial line 1.		
			Off	Indicates no serial communication.		

* ERR LED is also On during booting process.

NOTE: For information about the LEDs integrated into the Ethernet connector, refer to Ethernet Status LEDs, page 260

(1) For more information about the controller state description, refer to the M221 Logic Controller - Programming Guide (see Modicon M221, Logic Controller, Programming Guide).

(2) The controller detected an error but remains in RUNNING state. The ERR LED on the controller flashes. For more information, refer to M221 Logic Controller - Programming Guide.

Dimensions

The following figure shows the external dimensions of the logic controllers:

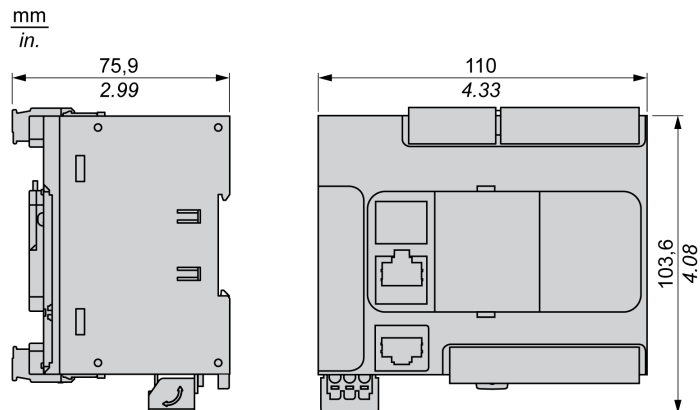

TM221C24U

What's in This Chapter

TM221C24U Presentation..... 119

Overview

This chapter describes the TM221C24• logic controller.

TM221C24U Presentation

Overview

The following features are integrated into the TM221C24U logic controller:

- 14 digital inputs
 - 4 fast inputs (HSC)
 - 10 regular inputs
- 10 digital outputs
 - 2 fast sink transistor outputs
 - 8 regular sink transistor outputs
- 2 analog inputs
- Communication ports
 - 1 serial line port
 - 1 USB mini-B programming port

Description

The following figure shows the different components of the logic controllers:

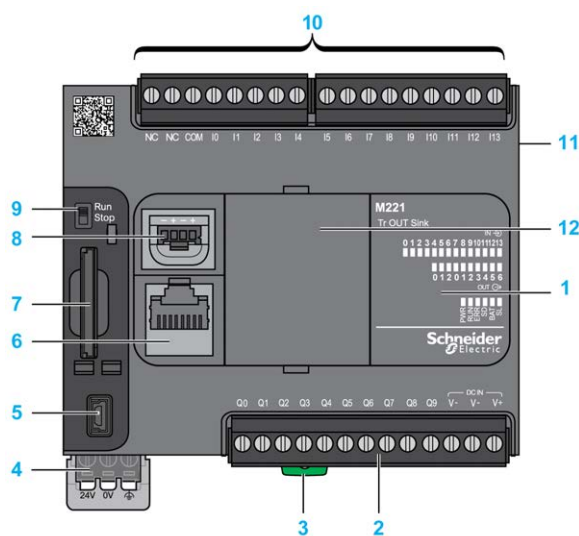

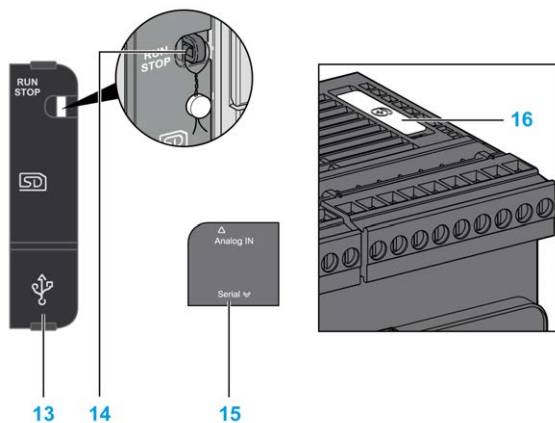

N°	Description	Refer to
1	Status LEDs	–
2	Output removable terminal block	Rules for Removable Screw Terminal Block, page 76
3	Clip-on lock for 35 mm (1.38 in.) top hat section rail (DIN-rail)	DIN Rail
4	24 Vdc power supply	Power supply, page 79
5	USB mini-B programming port / For terminal connection to a programming PC (EcoStruxure Machine Expert - Basic)	USB mini-B programming port , page 257
6	Serial line port 1 / RJ45 connector (RS-232 or RS-485)	Serial line 1, page 260
7	SD Card slot	SD Card Slot, page 55
8	2 analog inputs	Analog Inputs, page 174
9	Run/Stop switch	Run/Stop switch , page 53
10	Input removable terminal block	Rules for Removable Screw Terminal Block, page 76
11	I/O expansion connector	–
12	Cartridge slot	–
13	Protective cover (SD Card slot, Run/Stop switch and USB mini-B programming port)	–
14	Locking hook	–
15	Removable analog inputs cover	–
16	Battery holder	Installing and Replacing the Battery, page 45

Status LEDs

The following figure shows the status LEDs:



The following table describes the status LEDs:

Label	Function Type	Color	Status	Description		
				Controller States ⁽¹⁾	Prg Port Communication	Application Execution
PWR	Power	Green	On	Indicates that power is applied.		
			Off	Indicates that power is removed.		
RUN	Machine Status	Green	On	Indicates that the controller is running a valid application.		
			Flashing	Indicates that the controller has a valid application that is stopped.		
			Off	Indicates that the controller is not programmed.		
ERR	Error	Red	On*	EXCEPTION	Restricted	NO
			Flashing (with RUN status LED Off)	INTERNAL ERROR	Restricted	NO
			Slow flash	Minor error detected ⁽²⁾	Yes	Depends on the RUN status LED
			1 single flash	No application	Yes	Yes
SD	SD Card Access, page 55	Green	On	Indicates that the SD card is being accessed.		
			Flashing	Indicates that an error was detected during the SD card operation.		
			Off	Indicates no access (idle) or no card is present.		
BAT	Battery, page 44	Red	On	Indicates that the battery needs to be replaced.		
			Flashing	Indicates that the battery charge is low.		
			Off	Indicates that the battery is OK.		
SL	Serial line 1, page 260	Green	On	Indicates the status of Serial line 1.		
			Flashing	Indicates activity on Serial line 1.		
			Off	Indicates no serial communication.		

* ERR LED is also On during booting process.

NOTE: For information about the LEDs integrated into the Ethernet connector, refer to Ethernet Status LEDs, page 260

(1) For more information about the controller state description, refer to the M221 Logic Controller - Programming Guide (see Modicon M221, Logic Controller, Programming Guide).

(2) The controller detected an error but remains in RUNNING state. The ERR LED on the controller flashes. For more information, refer to M221 Logic Controller - Programming Guide.

Dimensions

The following figure shows the external dimensions of the logic controllers:

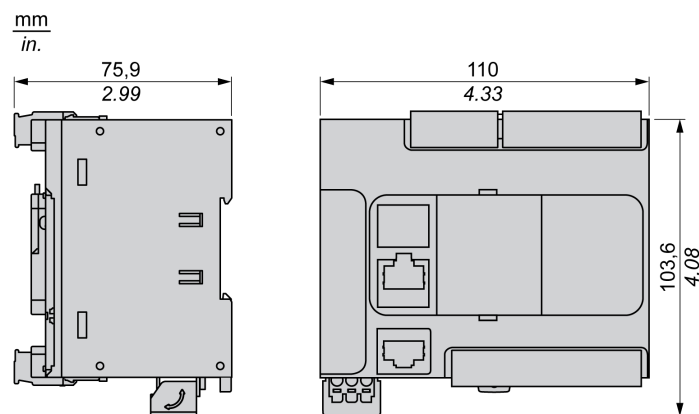

TM221CE24U

What's in This Chapter

TM221CE24U Presentation 122

Overview

This chapter describes the TM221CE24U logic controller.

TM221CE24U Presentation

Overview

The following features are integrated into the TM221CE24U logic controller:

- 14 digital inputs
 - 4 fast inputs (HSC)
 - 10 regular inputs
- 10 digital outputs
 - 2 fast sink transistor outputs
 - 8 regular sink transistor outputs
- 2 analog inputs
- Communication ports
 - 1 serial line port
 - 1 USB mini-B programming port
 - 1 Ethernet port

Description

The following figure shows the different components of the logic controllers:

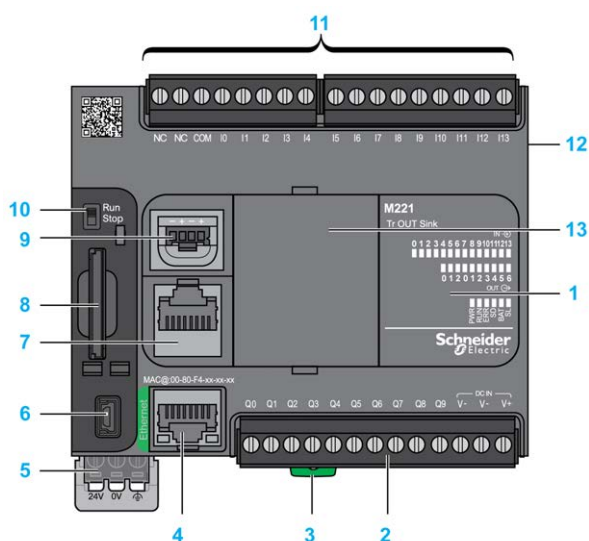

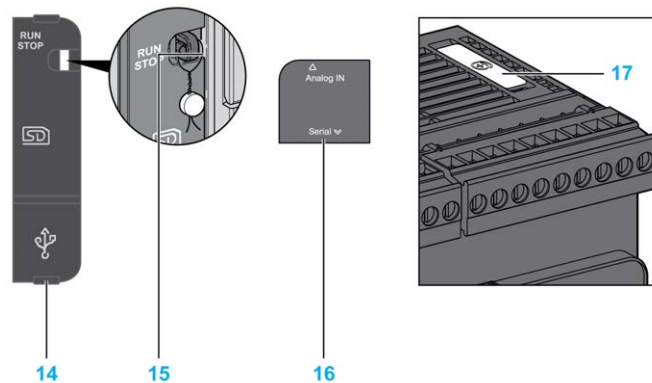

N°	Description	Refer to
1	Status LEDs	–
2	Output removable terminal block	Rules for Removable Screw Terminal Block, page 76
3	Clip-on lock for 35 mm (1.38 in.) top hat section rail (DIN-rail)	DIN Rail
4	Ethernet port / RJ45 connector	Ethernet port, page 258
5	24 Vdc power supply	Power supply, page 79
6	USB mini-B programming port / For terminal connection to a programming PC (EcoStruxure Machine Expert - Basic)	USB mini-B programming port , page 257
7	Serial line port 1 / RJ45 connector (RS-232 or RS-485)	Serial line 1, page 260
8	SD Card slot	SD Card Slot, page 55
9	2 analog inputs	Analog Inputs, page 174
10	Run/Stop switch	Run/Stop switch , page 53
11	Input removable terminal block	Rules for Removable Screw Terminal Block, page 76
12	I/O expansion connector	–
13	Cartridge slot	–
14	Protective cover (SD Card slot, Run/Stop switch and USB mini-B programming port)	–
15	Locking hook	–
16	Removable analog inputs cover	–
17	Battery holder	Installing and Replacing the Battery, page 45

Status LEDs

The following figure shows the status LEDs:



The following table describes the status LEDs:

Label	Function Type	Color	Status	Description		
				Controller States ⁽¹⁾	Prg Port Communication	Application Execution
PWR	Power	Green	On	Indicates that power is applied.		
			Off	Indicates that power is removed.		
RUN	Machine Status	Green	On	Indicates that the controller is running a valid application.		
			Flashing	Indicates that the controller has a valid application that is stopped.		
			Off	Indicates that the controller is not programmed.		
ERR	Error	Red	On*	EXCEPTION	Restricted	NO
			Flashing (with RUN status LED Off)	INTERNAL ERROR	Restricted	NO
			Slow flash	Minor error detected ⁽²⁾	Yes	Depends on the RUN status LED
			1 single flash	No application	Yes	Yes
SD	SD Card Access, page 55	Green	On	Indicates that the SD card is being accessed.		
			Flashing	Indicates that an error was detected during the SD card operation.		
			Off	Indicates no access (idle) or no card is present.		
BAT	Battery, page 44	Red	On	Indicates that the battery needs to be replaced.		
			Flashing	Indicates that the battery charge is low.		
			Off	Indicates that the battery is OK.		
SL	Serial line 1, page 260	Green	On	Indicates the status of Serial line 1.		
			Flashing	Indicates activity on Serial line 1.		
			Off	Indicates no serial communication.		

* ERR LED is also On during booting process.

NOTE: For information about the LEDs integrated into the Ethernet connector, refer to Ethernet Status LEDs, page 260

(1) For more information about the controller state description, refer to the M221 Logic Controller - Programming Guide (see Modicon M221, Logic Controller, Programming Guide).

(2) The controller detected an error but remains in RUNNING state. The ERR LED on the controller flashes. For more information, refer to M221 Logic Controller - Programming Guide.

Dimensions

The following figure shows the external dimensions of the logic controllers:

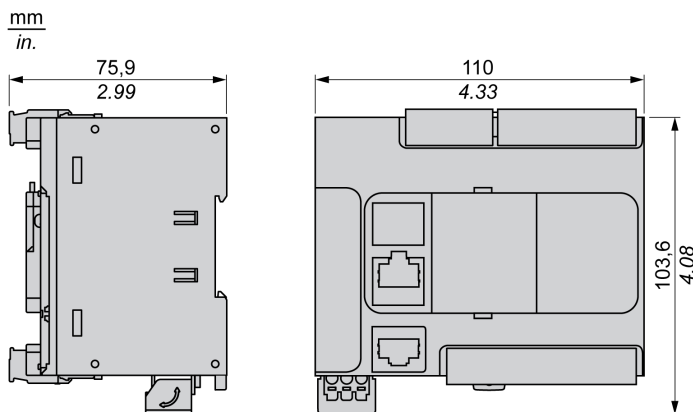

TM221C40R

What's in This Chapter

TM221C40R Presentation.....	125
-----------------------------	-----

Overview

This chapter describes the TM221C40R logic controller.

TM221C40R Presentation

Overview

The following features are integrated into the TM221C40R logic controllers:

- 24 digital inputs
 - 4 fast inputs (HSC)
 - 20 regular inputs
- 16 digital outputs
 - 16 relay outputs
- 2 analog inputs
- Communication ports
 - 1 serial line port
 - 1 USB mini-B programming port

Description

The following figure shows the different components of the logic controllers:

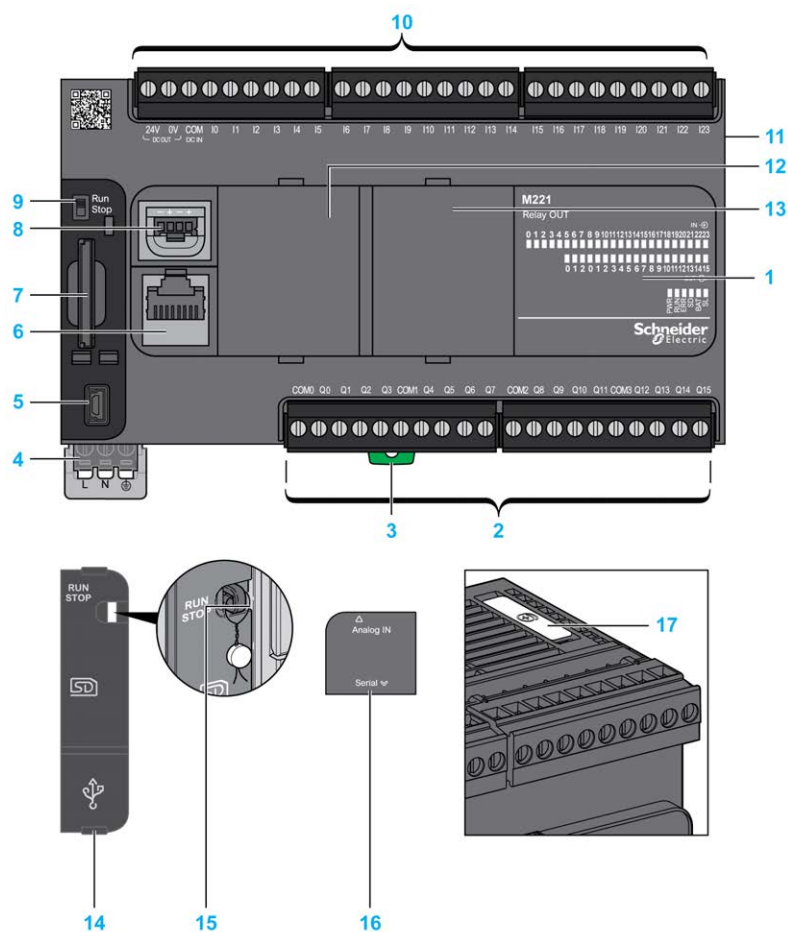

N°	Description	Refer to
1	Status LEDs	–
2	Output removable terminal block	Rules for Removable Screw Terminal Block, page 76
3	Clip-on lock for 35 mm (1.38 in.) top hat section rail (DIN-rail)	DIN Rail
4	100...240 Vac power supply	Power supply, page 84
5	USB mini-B programming port / For terminal connection to a programming PC (EcoStruxure Machine Expert - Basic)	USB mini-B programming port , page 257
6	Serial line port 1 / RJ45 connector (RS-232 or RS-485)	Serial line 1, page 260
7	SD Card slot	SD Card Slot, page 55
8	2 analog inputs	Analog Inputs, page 174
9	Run/Stop switch	Run/Stop switch , page 53
10	Input removable terminal block and embedded power supply used for connecting sensors to the inputs. ⁽¹⁾	Rules for Removable Screw Terminal Block, page 76
11	I/O expansion connector	–
12	Cartridge slot 1	–
13	Cartridge slot 2	–
14	Protective cover (SD Card slot, Run/Stop switch and USB mini-B programming port)	–
15	Locking hook	–
16	Removable analog inputs cover	–

N°	Description	Refer to
17	Battery holder	Installing and Replacing the Battery, page 45
<p>(1) Embedded power supply characteristics:</p> <ul style="list-style-type: none"> • Voltage: 24 V -15%...+10% isolated • I_{max}: 250 mA • No protection and no overload detection <p>Refer to Embedded I/O Channels, page 147.</p>		

Status LEDs

The following figure shows the status LEDs:

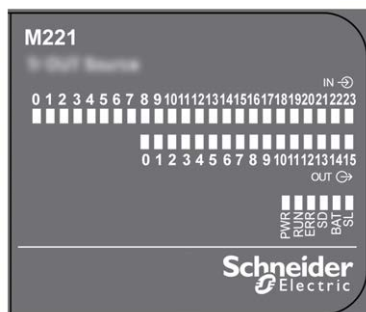

The following table describes the status LEDs:

Label	Function Type	Color	Status	Description		
				Controller States ⁽¹⁾	Prg Port Communication	Application Execution
PWR	Power	Green	On	Indicates that power is applied.		
			Off	Indicates that power is removed.		
RUN	Machine Status	Green	On	Indicates that the controller is running a valid application.		
			Flashing	Indicates that the controller has a valid application that is stopped.		
			Off	Indicates that the controller is not programmed.		
ERR	Error	Red	On*	EXCEPTION	Restricted	NO
			Flashing (with RUN status LED Off)	INTERNAL ERROR	Restricted	NO
			Slow flash	Minor error detected ⁽²⁾	Yes	Depends on the RUN status LED
			1 single flash	No application	Yes	Yes
SD	SD Card Access, page 55	Green	On	Indicates that the SD card is being accessed.		
			Flashing	Indicates that an error was detected during the SD card operation.		
			Off	Indicates no access (idle) or no card is present.		
BAT	Battery, page 44	Red	On	Indicates that the battery needs to be replaced.		
			Flashing	Indicates that the battery charge is low.		
			Off	Indicates that the battery is OK.		
SL	Serial line 1, page 260	Green	On	Indicates the status of Serial line 1.		
			Flashing	Indicates activity on Serial line 1.		
			Off	Indicates no serial communication.		

Label	Function Type	Color	Status	Description		
				Controller States ⁽¹⁾	Prg Port Communication	Application Execution
* ERR LED is also On during booting process.						
NOTE: For information about the LEDs integrated into the Ethernet connector, refer to Ethernet Status LEDs, page 260						
(1) For more information about the controller state description, refer to the M221 Logic Controller - Programming Guide (see Modicon M221, Logic Controller, Programming Guide).						
(2) The controller detected an error but remains in RUNNING state. The ERR LED on the controller flashes. For more information, refer to M221 Logic Controller - Programming Guide.						

Dimensions

The following figure shows the external dimensions of the logic controllers:

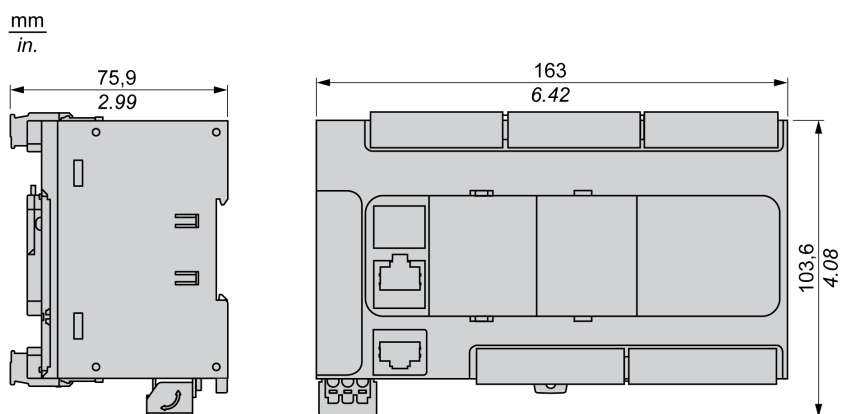

TM221CE40R

What's in This Chapter

TM221CE40R Presentation	129
-------------------------------	-----

Overview

This chapter describes the TM221CE40R logic controller.

TM221CE40R Presentation

Overview

The following features are integrated into the TM221CE40R logic controllers:

- 24 digital inputs
 - 4 fast inputs (HSC)
 - 20 regular inputs
- 16 digital outputs
 - 16 relay outputs
- 2 analog inputs
- Communication ports
 - 1 serial line port
 - 1 USB mini-B programming port
 - 1 Ethernet port

Description

The following figure shows the different components of the logic controllers:

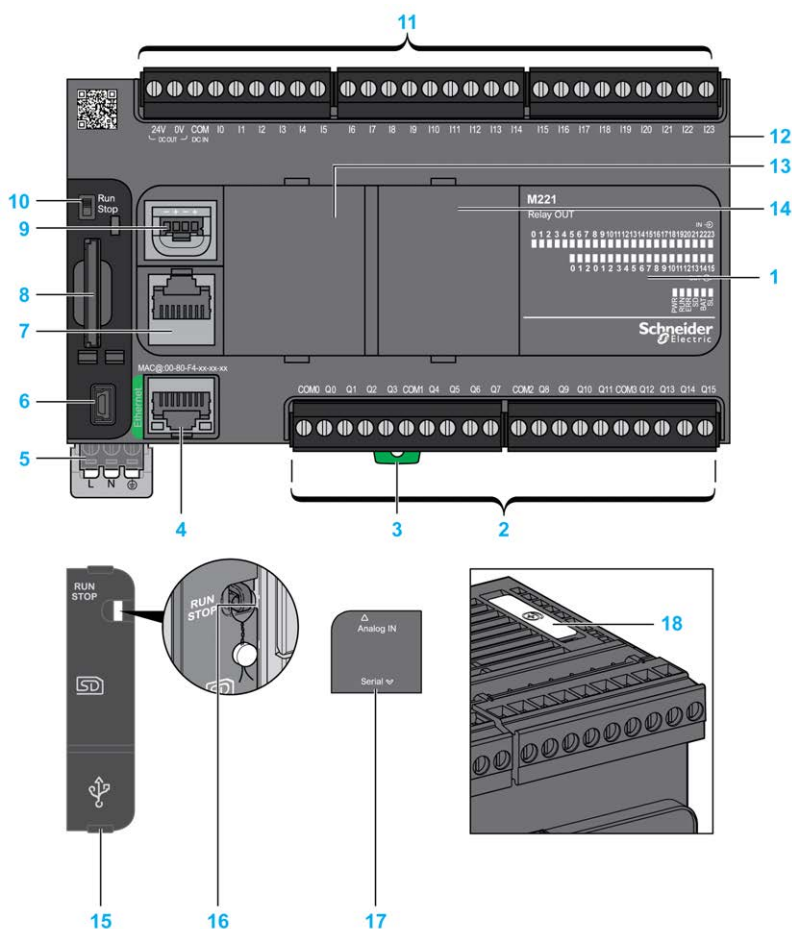

N°	Description	Refer to
1	Status LEDs	–
2	Output removable terminal block	Rules for Removable Screw Terminal Block, page 76
3	Clip-on lock for 35 mm (1.38 in.) top hat section rail (DIN-rail)	DIN Rail
4	Ethernet port / RJ45 connector	Ethernet port, page 258
5	100...240 Vac power supply	Power supply, page 84
6	USB mini-B programming port / For terminal connection to a programming PC (EcoStruxure Machine Expert - Basic)	USB mini-B programming port , page 257
7	Serial line port 1 / RJ45 connector (RS-232 or RS-485)	Serial line 1, page 260
8	SD Card slot	SD Card Slot, page 55
9	2 analog inputs	Analog Inputs, page 174
10	Run/Stop switch	Run/Stop switch , page 53
11	Input removable terminal block and embedded power supply used for connecting sensors to the inputs. ⁽¹⁾	Rules for Removable Screw Terminal Block, page 76
12	I/O expansion connector	–
13	Cartridge slot 1	–
14	Cartridge slot 2	–
15	Protective cover (SD Card slot, Run/Stop switch and USB mini-B programming port)	–
16	Locking hook	–
17	Removable analog inputs cover	–

N°	Description	Refer to
18	Battery holder	Installing and Replacing the Battery, page 45
<p>(1) Embedded power supply characteristics:</p> <ul style="list-style-type: none"> • Voltage: 24 V -15%...+10% isolated • I_{max}: 250 mA • No protection and no overload detection <p>Refer to Embedded I/O Channels, page 147.</p>		

Status LEDs

The following figure shows the status LEDs:

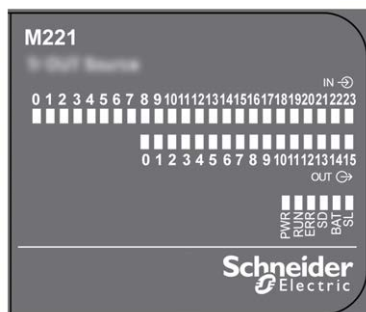

The following table describes the status LEDs:

Label	Function Type	Color	Status	Description		
				Controller States ⁽¹⁾	Prg Port Communication	Application Execution
PWR	Power	Green	On	Indicates that power is applied.		
			Off	Indicates that power is removed.		
RUN	Machine Status	Green	On	Indicates that the controller is running a valid application.		
			Flashing	Indicates that the controller has a valid application that is stopped.		
			Off	Indicates that the controller is not programmed.		
ERR	Error	Red	On*	EXCEPTION	Restricted	NO
			Flashing (with RUN status LED Off)	INTERNAL ERROR	Restricted	NO
			Slow flash	Minor error detected ⁽²⁾	Yes	Depends on the RUN status LED
			1 single flash	No application	Yes	Yes
SD	SD Card Access, page 55	Green	On	Indicates that the SD card is being accessed.		
			Flashing	Indicates that an error was detected during the SD card operation.		
			Off	Indicates no access (idle) or no card is present.		
BAT	Battery, page 44	Red	On	Indicates that the battery needs to be replaced.		
			Flashing	Indicates that the battery charge is low.		
			Off	Indicates that the battery is OK.		
SL	Serial line 1, page 260	Green	On	Indicates the status of Serial line 1.		
			Flashing	Indicates activity on Serial line 1.		
			Off	Indicates no serial communication.		

Label	Function Type	Color	Status	Description		
				Controller States ⁽¹⁾	Prg Port Communication	Application Execution
* ERR LED is also On during booting process.						
NOTE: For information about the LEDs integrated into the Ethernet connector, refer to Ethernet Status LEDs, page 260						
(1) For more information about the controller state description, refer to the M221 Logic Controller - Programming Guide (see Modicon M221, Logic Controller, Programming Guide).						
(2) The controller detected an error but remains in RUNNING state. The ERR LED on the controller flashes. For more information, refer to M221 Logic Controller - Programming Guide.						

Dimensions

The following figure shows the external dimensions of the logic controllers:

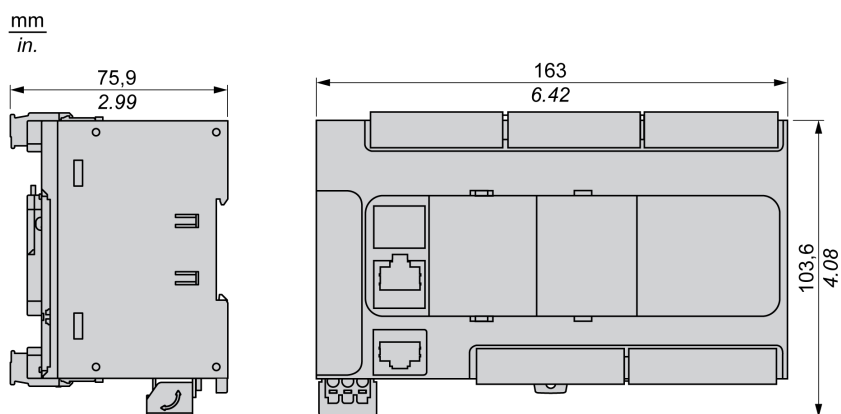

TM221C40T

What's in This Chapter

TM221C40T Presentation	133
------------------------------	-----

Overview

This chapter describes the TM221C40T logic controller.

TM221C40T Presentation

Overview

The following features are integrated into the TM221C40T logic controller:

- 24 digital inputs
 - 4 fast inputs (HSC)
 - 20 regular inputs
- 16 digital outputs
 - 2 fast source transistor outputs
 - 14 regular source transistor outputs
- 2 analog inputs
- Communication ports
 - 1 serial line port
 - 1 USB mini-B programming port

Description

The following figure shows the different components of the logic controllers:

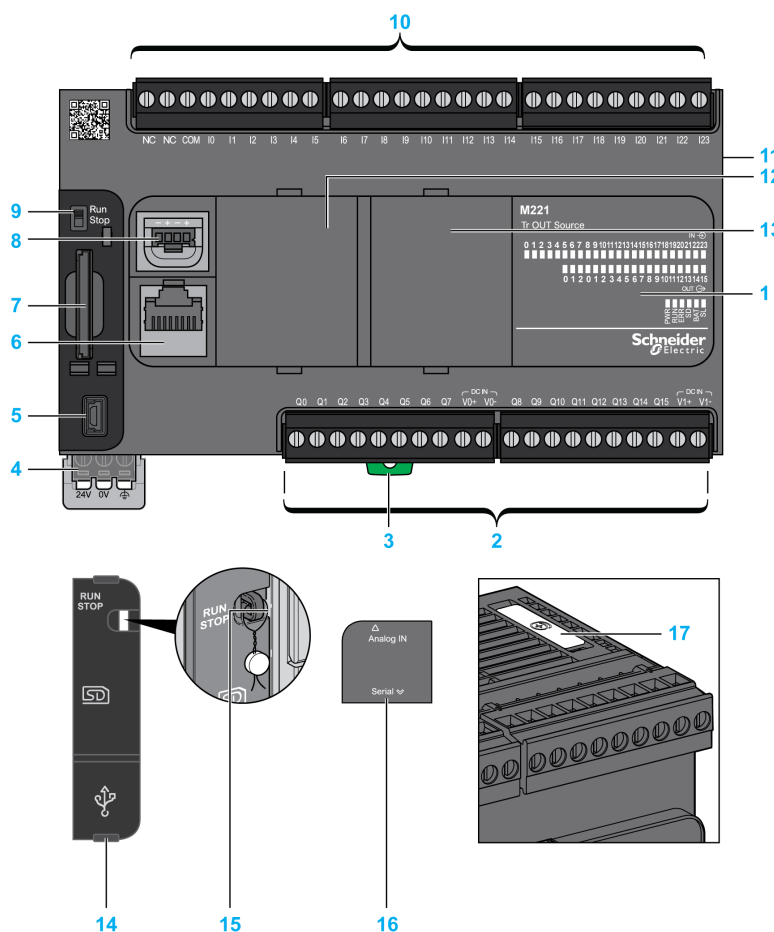

N°	Description	Refer to
1	Status LEDs	–
2	Output removable terminal block	Rules for Removable Screw Terminal Block, page 76
3	Clip-on lock for 35 mm (1.38 in.) top hat section rail (DIN-rail)	DIN Rail
4	24 Vdc power supply	Power supply, page 79
5	USB mini-B programming port / For terminal connection to a programming PC (EcoStruxure Machine Expert - Basic)	USB mini-B programming port , page 257
6	Serial line port 1 / RJ45 connector (RS-232 or RS-485)	Serial line 1, page 260
7	SD Card slot	SD Card Slot, page 55
8	2 analog inputs	Analog Inputs, page 174
9	Run/Stop switch	Run/Stop switch , page 53
10	Input removable terminal block	Rules for Removable Screw Terminal Block, page 76
11	I/O expansion connector	–
12	Cartridge slot 1	–
13	Cartridge slot 2	–
14	Protective cover (SD Card slot, Run/Stop switch and USB mini-B programming port)	–
15	Locking hook	–
16	Removable analog inputs cover	–
17	Battery holder	Installing and Replacing the Battery, page 45

Status LEDs

The following figure shows the status LEDs:

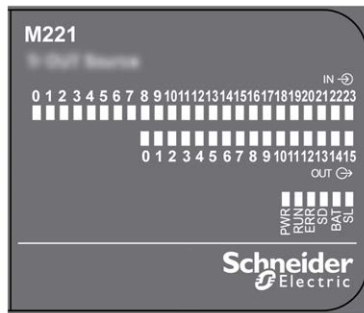

The following table describes the status LEDs:

Label	Function Type	Color	Status	Description		
				Controller States ⁽¹⁾	Prg Port Communication	Application Execution
PWR	Power	Green	On	Indicates that power is applied.		
			Off	Indicates that power is removed.		
RUN	Machine Status	Green	On	Indicates that the controller is running a valid application.		
			Flashing	Indicates that the controller has a valid application that is stopped.		
			Off	Indicates that the controller is not programmed.		
ERR	Error	Red	On*	EXCEPTION	Restricted	NO
			Flashing (with RUN status LED Off)	INTERNAL ERROR	Restricted	NO
			Slow flash	Minor error detected ⁽²⁾	Yes	Depends on the RUN status LED
			1 single flash	No application	Yes	Yes
SD	SD Card Access, page 55	Green	On	Indicates that the SD card is being accessed.		
			Flashing	Indicates that an error was detected during the SD card operation.		
			Off	Indicates no access (idle) or no card is present.		
BAT	Battery, page 44	Red	On	Indicates that the battery needs to be replaced.		
			Flashing	Indicates that the battery charge is low.		
			Off	Indicates that the battery is OK.		
SL	Serial line 1, page 260	Green	On	Indicates the status of Serial line 1.		
			Flashing	Indicates activity on Serial line 1.		
			Off	Indicates no serial communication.		

* ERR LED is also On during booting process.

NOTE: For information about the LEDs integrated into the Ethernet connector, refer to Ethernet Status LEDs, page 260

(1) For more information about the controller state description, refer to the M221 Logic Controller - Programming Guide (see Modicon M221, Logic Controller, Programming Guide).

(2) The controller detected an error but remains in RUNNING state. The ERR LED on the controller flashes. For more information, refer to M221 Logic Controller - Programming Guide.

Dimensions

The following figure shows the external dimensions of the logic controllers:

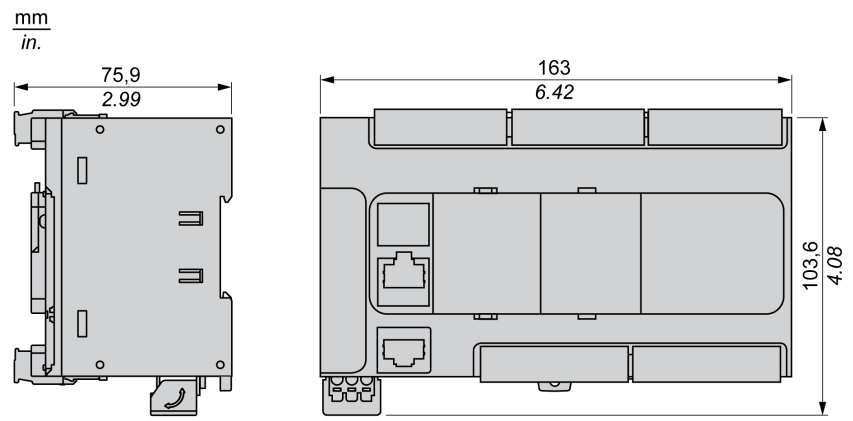

TM221CE40T

What's in This Chapter

TM221CE40T Presentation.....	137
------------------------------	-----

Overview

This chapter describes the TM221CE40T controller.

TM221CE40T Presentation

Overview

The following features are integrated into the TM221CE40T logic controllers:

- 24 digital inputs
 - 4 fast inputs (HSC)
 - 20 regular inputs
- 16 digital outputs
 - 2 fast source transistor outputs
 - 14 regular source transistor outputs
- 2 analog inputs
- Communication ports
 - 1 serial line port
 - 1 USB mini-B programming port
 - 1 Ethernet port

Description

The following figure shows the different components of the logic controllers:

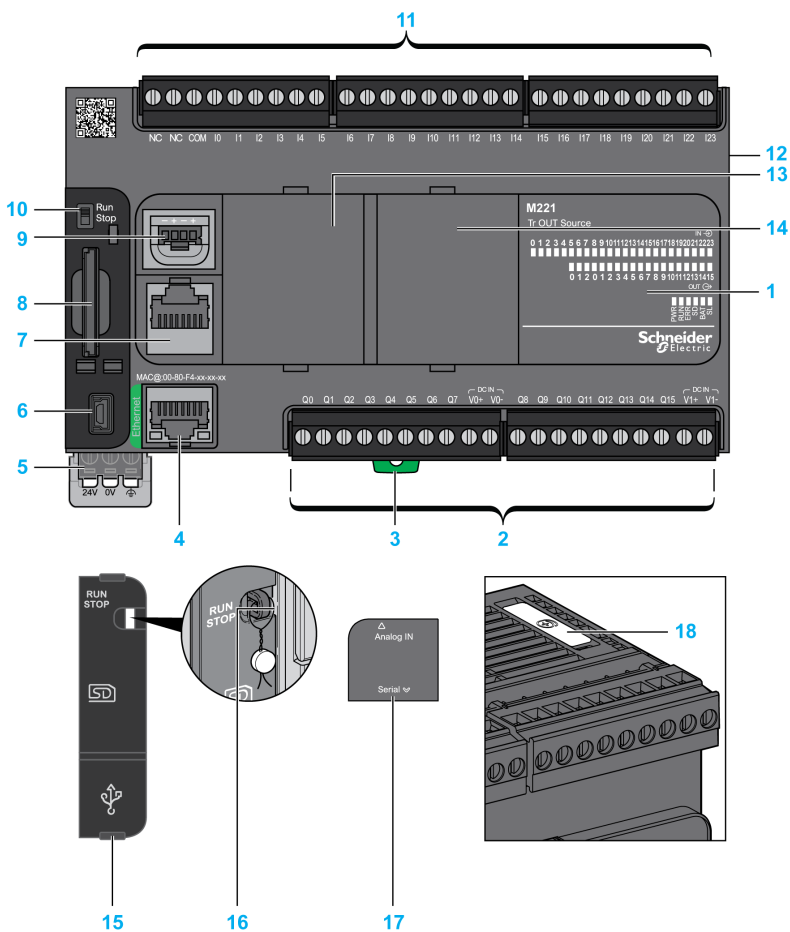

N°	Description	Refer to
1	Status LEDs	–
2	Output removable terminal block	Rules for Removable Screw Terminal Block, page 76
3	Clip-on lock for 35 mm (1.38 in.) top hat section rail (DIN-rail)	DIN Rail
4	Ethernet port / RJ45 connector	Ethernet port, page 258
5	24 Vdc power supply	Power supply, page 79
6	USB mini-B programming port / For terminal connection to a programming PC (EcoStruxure Machine Expert - Basic)	USB mini-B programming port , page 257
7	Serial line port 1 / RJ45 connector (RS-232 or RS-485)	Serial line 1, page 260
8	SD Card slot	SD Card Slot, page 55
9	2 analog inputs	Analog Inputs, page 174
10	Run/Stop switch	Run/Stop switch , page 53
11	Input removable terminal block	Rules for Removable Screw Terminal Block, page 76
12	I/O expansion connector	–
13	Cartridge slot 1	–
14	Cartridge slot 2	–
15	Protective cover (SD Card slot, Run/Stop switch and USB mini-B programming port)	–
16	Locking hook	–

N°	Description	Refer to
17	Removable analog inputs cover	–
18	Battery holder	Installing and Replacing the Battery, page 45

Status LEDs

The following figure shows the status LEDs:

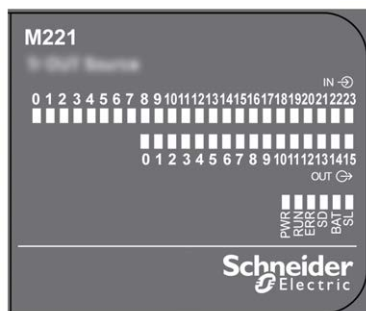

The following table describes the status LEDs:

Label	Function Type	Color	Status	Description		
				Controller States ⁽¹⁾	Prg Port Communication	Application Execution
PWR	Power	Green	On	Indicates that power is applied.		
			Off	Indicates that power is removed.		
RUN	Machine Status	Green	On	Indicates that the controller is running a valid application.		
			Flashing	Indicates that the controller has a valid application that is stopped.		
			Off	Indicates that the controller is not programmed.		
ERR	Error	Red	On*	EXCEPTION	Restricted	NO
			Flashing (with RUN status LED Off)	INTERNAL ERROR	Restricted	NO
			Slow flash	Minor error detected ⁽²⁾	Yes	Depends on the RUN status LED
			1 single flash	No application	Yes	Yes
SD	SD Card Access, page 55	Green	On	Indicates that the SD card is being accessed.		
			Flashing	Indicates that an error was detected during the SD card operation.		
			Off	Indicates no access (idle) or no card is present.		
BAT	Battery, page 44	Red	On	Indicates that the battery needs to be replaced.		
			Flashing	Indicates that the battery charge is low.		
			Off	Indicates that the battery is OK.		
SL	Serial line 1, page 260	Green	On	Indicates the status of Serial line 1.		
			Flashing	Indicates activity on Serial line 1.		
			Off	Indicates no serial communication.		

* ERR LED is also On during booting process.

NOTE: For information about the LEDs integrated into the Ethernet connector, refer to Ethernet Status LEDs, page 260

(1) For more information about the controller state description, refer to the M221 Logic Controller - Programming Guide (see Modicon M221, Logic Controller, Programming Guide).

(2) The controller detected an error but remains in RUNNING state. The ERR LED on the controller flashes. For more information, refer to M221 Logic Controller - Programming Guide.

Dimensions

The following figure shows the external dimensions of the logic controllers:

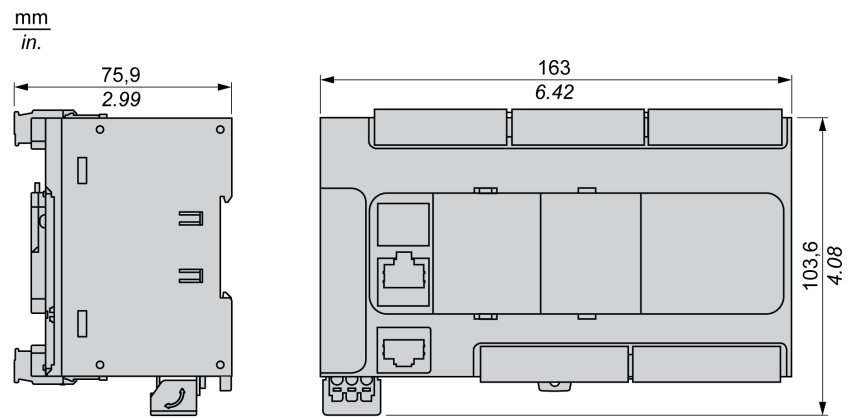

TM221C40U

What's in This Chapter

TM221C40U Presentation..... 141

Overview

This chapter describes the TM221C40U logic controller.

TM221C40U Presentation

Overview

The following features are integrated into the TM221C40U logic controller:

- 24 digital inputs
 - 4 fast inputs (HSC)
 - 20 regular inputs
- 16 digital outputs
 - 4 fast sink transistor outputs
 - 12 regular sink transistor outputs
- 2 analog inputs
- Communication ports
 - 1 serial line port
 - 1 USB mini-B programming port

Description

The following figure shows the different components of the logic controllers:

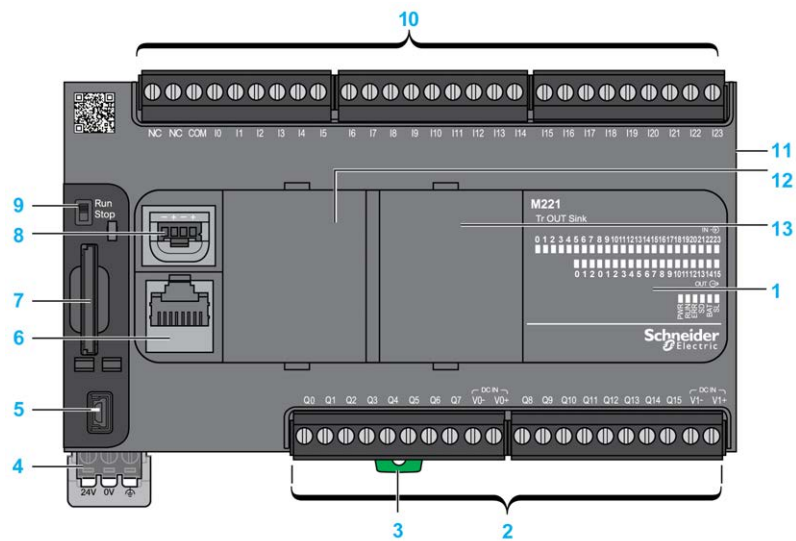

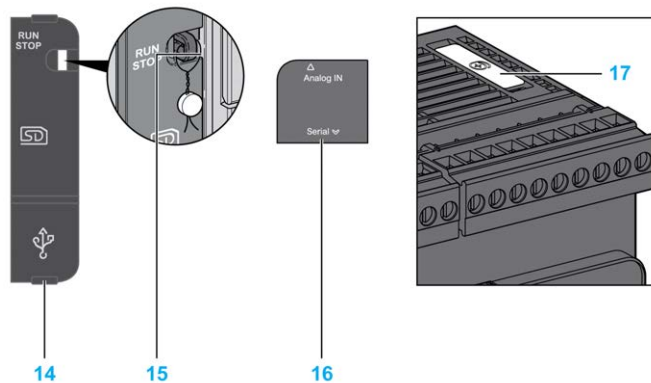

N°	Description	Refer to
1	Status LEDs	–
2	Output removable terminal block	Rules for Removable Screw Terminal Block, page 76
3	Clip-on lock for 35 mm (1.38 in.) top hat section rail (DIN-rail)	DIN Rail
4	24 Vdc power supply	Power supply, page 79
5	USB mini-B programming port / For terminal connection to a programming PC (EcoStruxure Machine Expert - Basic)	USB mini-B programming port , page 257
6	Serial line port 1 / RJ45 connector (RS-232 or RS-485)	Serial line 1, page 260
7	SD Card slot	SD Card Slot, page 55
8	2 analog inputs	Analog Inputs, page 174
9	Run/Stop switch	Run/Stop switch , page 53
10	Input removable terminal block	Rules for Removable Screw Terminal Block, page 76
11	I/O expansion connector	–
12	Cartridge slot 1	–
13	Cartridge slot 2	–
14	Protective cover (SD Card slot, Run/Stop switch and USB mini-B programming port)	–
15	Locking hook	–
16	Removable analog inputs cover	–
17	Battery holder	Installing and Replacing the Battery, page 45

Status LEDs

The following figure shows the status LEDs:

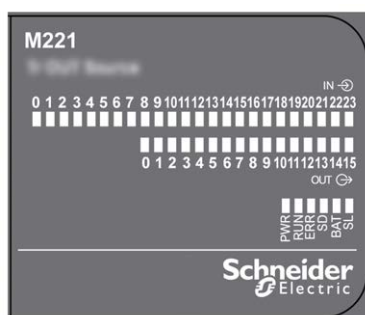

The following table describes the status LEDs:

Label	Function Type	Color	Status	Description		
				Controller States ⁽¹⁾	Prg Port Communication	Application Execution
PWR	Power	Green	On	Indicates that power is applied.		
			Off	Indicates that power is removed.		
RUN	Machine Status	Green	On	Indicates that the controller is running a valid application.		
			Flashing	Indicates that the controller has a valid application that is stopped.		
			Off	Indicates that the controller is not programmed.		
ERR	Error	Red	On*	EXCEPTION	Restricted	NO
			Flashing (with RUN status LED Off)	INTERNAL ERROR	Restricted	NO
			Slow flash	Minor error detected ⁽²⁾	Yes	Depends on the RUN status LED
			1 single flash	No application	Yes	Yes
SD	SD Card Access, page 55	Green	On	Indicates that the SD card is being accessed.		
			Flashing	Indicates that an error was detected during the SD card operation.		
			Off	Indicates no access (idle) or no card is present.		
BAT	Battery, page 44	Red	On	Indicates that the battery needs to be replaced.		
			Flashing	Indicates that the battery charge is low.		
			Off	Indicates that the battery is OK.		
SL	Serial line 1, page 260	Green	On	Indicates the status of Serial line 1.		
			Flashing	Indicates activity on Serial line 1.		
			Off	Indicates no serial communication.		

* ERR LED is also On during booting process.

NOTE: For information about the LEDs integrated into the Ethernet connector, refer to Ethernet Status LEDs, page 260

(1) For more information about the controller state description, refer to the M221 Logic Controller - Programming Guide (see Modicon M221, Logic Controller, Programming Guide).

(2) The controller detected an error but remains in RUNNING state. The ERR LED on the controller flashes. For more information, refer to M221 Logic Controller - Programming Guide.

Dimensions

The following figure shows the external dimensions of the logic controllers:

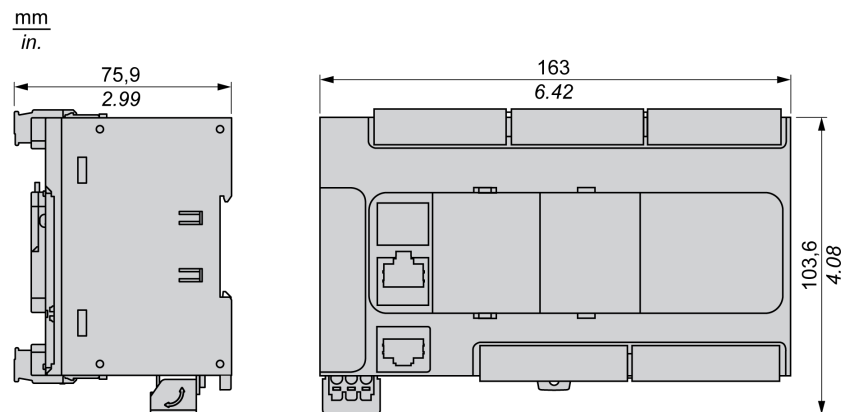

TM221CE40U

What's in This Chapter

TM221CE40U Presentation 144

Overview

This chapter describes the TM221CE40U logic controller.

TM221CE40U Presentation

Overview

The following features are integrated into the TM221CE40U logic controller:

- 24 digital inputs
 - 4 fast inputs (HSC)
 - 20 regular inputs
- 16 digital outputs
 - 4 fast sink transistor outputs
 - 12 regular sink transistor outputs
- 2 analog inputs
- Communication ports
 - 1 serial line port
 - 1 USB mini-B programming port
 - 1 Ethernet port

Description

The following figure shows the different components of the logic controllers:

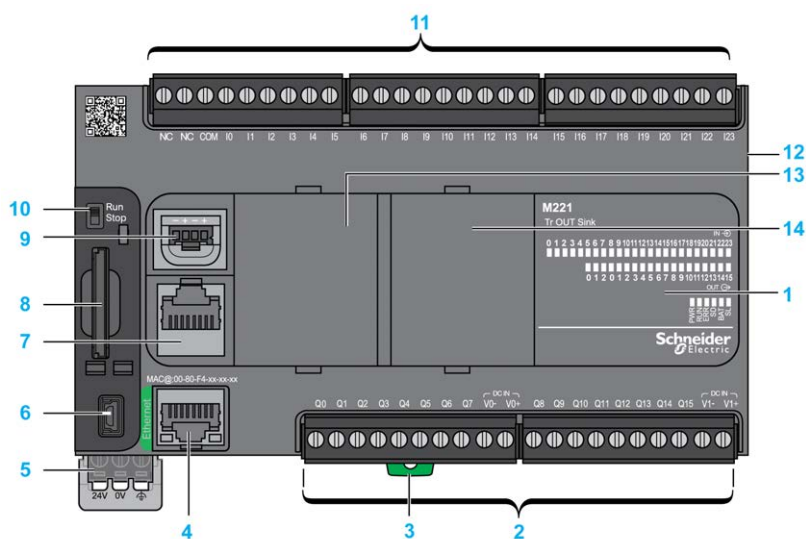

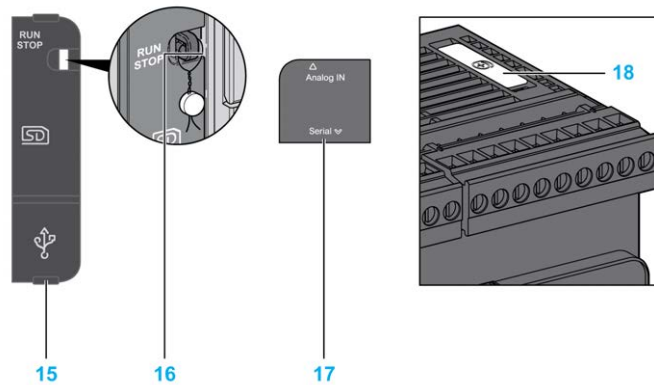

N°	Description	Refer to
1	Status LEDs	–
2	Output removable terminal block	Rules for Removable Screw Terminal Block, page 76
3	Clip-on lock for 35 mm (1.38 in.) top hat section rail (DIN-rail)	DIN Rail
4	Ethernet port / RJ45 connector	Ethernet port, page 258
5	24 Vdc power supply	Power supply, page 79
6	USB mini-B programming port / For terminal connection to a programming PC (EcoStruxure Machine Expert - Basic)	USB mini-B programming port , page 257
7	Serial line port 1 / RJ45 connector (RS-232 or RS-485)	Serial line 1, page 260
8	SD Card slot	SD Card Slot, page 55
9	2 analog inputs	Analog Inputs, page 174
10	Run/Stop switch	Run/Stop switch , page 53
11	Input removable terminal block	Rules for Removable Screw Terminal Block, page 76
12	I/O expansion connector	–
13	Cartridge slot 1	–
14	Cartridge slot 2	–
15	Protective cover (SD Card slot, Run/Stop switch and USB mini-B programming port)	–
16	Locking hook	–
17	Removable analog inputs cover	–
18	Battery holder	Installing and Replacing the Battery, page 45

Status LEDs

The following figure shows the status LEDs:

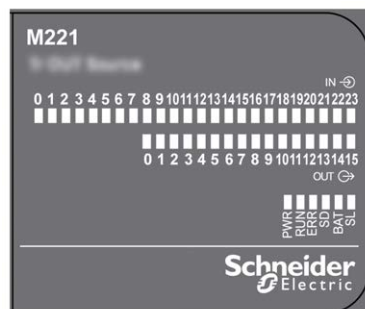

The following table describes the status LEDs:

Label	Function Type	Color	Status	Description		
				Controller States ⁽¹⁾	Prg Port Communication	Application Execution
PWR	Power	Green	On	Indicates that power is applied.		
			Off	Indicates that power is removed.		
RUN	Machine Status	Green	On	Indicates that the controller is running a valid application.		
			Flashing	Indicates that the controller has a valid application that is stopped.		
			Off	Indicates that the controller is not programmed.		
ERR	Error	Red	On*	EXCEPTION	Restricted	NO
			Flashing (with RUN status LED Off)	INTERNAL ERROR	Restricted	NO
			Slow flash	Minor error detected ⁽²⁾	Yes	Depends on the RUN status LED
			1 single flash	No application	Yes	Yes
SD	SD Card Access, page 55	Green	On	Indicates that the SD card is being accessed.		
			Flashing	Indicates that an error was detected during the SD card operation.		
			Off	Indicates no access (idle) or no card is present.		
BAT	Battery, page 44	Red	On	Indicates that the battery needs to be replaced.		
			Flashing	Indicates that the battery charge is low.		
			Off	Indicates that the battery is OK.		
SL	Serial line 1, page 260	Green	On	Indicates the status of Serial line 1.		
			Flashing	Indicates activity on Serial line 1.		
			Off	Indicates no serial communication.		

* ERR LED is also On during booting process.

NOTE: For information about the LEDs integrated into the Ethernet connector, refer to Ethernet Status LEDs, page 260

(1) For more information about the controller state description, refer to the M221 Logic Controller - Programming Guide (see Modicon M221, Logic Controller, Programming Guide).

(2) The controller detected an error but remains in RUNNING state. The ERR LED on the controller flashes. For more information, refer to M221 Logic Controller - Programming Guide.

Dimensions

The following figure shows the external dimensions of the logic controllers:

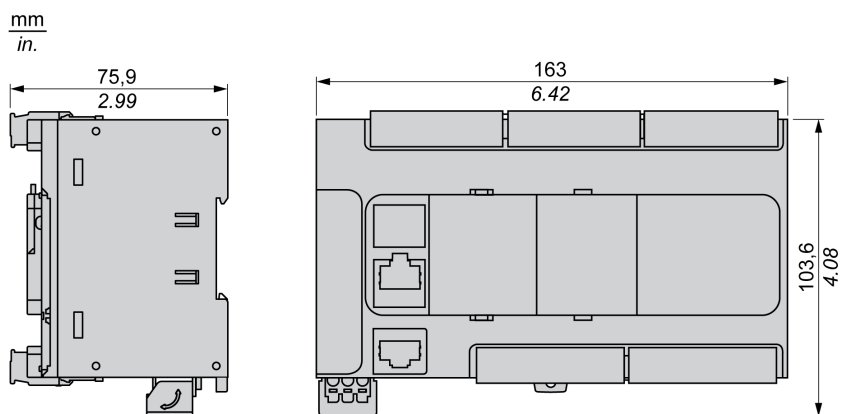

Embedded I/O Channels

What's in This Chapter

Digital Inputs..... 147
 Relay Outputs..... 160
 Regular and Fast Transistor Outputs..... 166
 Analog Inputs..... 174

Overview

This chapter describes the embedded I/O channels.

Digital Inputs

Overview

The Modicon TM221C Logic Controller has digital inputs embedded:

Reference	Total number of digital inputs	Fast inputs which can be used as 100 kHz HSC inputs	Regular inputs
TM221C16• TM221CE16•	9	4	5
TM221C24• TM221CE24•	14	4	10
TM221C40• TM221CE40•	24	4	20

For more information, refer to Input Management, page 48.

⚠ DANGER

FIRE HAZARD

- Use only the correct wire sizes for the maximum current capacity of the I/O channels and power supplies.
- For relay output (2 A) wiring, use conductors of at least 0.5 mm² (AWG 20) with a temperature rating of at least 80 °C (176 °F).
- For common conductors of relay output wiring (7 A), or relay output wiring greater than 2 A, use conductors of at least 1.0 mm² (AWG 16) with a temperature rating of at least 80 °C (176 °F).

Failure to follow these instructions will result in death or serious injury.

⚠ WARNING

UNINTENDED EQUIPMENT OPERATION

Do not exceed any of the rated values specified in the environmental and electrical characteristics tables.

Failure to follow these instructions can result in death, serious injury, or equipment damage.

Regular Input Characteristics

The following table describes the characteristics of the TM221C Logic Controller regular inputs:

Characteristic		Value		
		TM221C16• TM221CE16•	TM221C24• TM221CE24•	TM221C40• TM221CE40•
Number of regular inputs		5 inputs (I2, I3, I4, I5, I8)	10 inputs (I2...I5, I8...I13)	20 inputs (I2...I5, I8...I23)
Number of channel groups		1 common line for I0...I8	1 common line for I0...I13	1 common line for I0...I23
Input type		Type 1 (IEC/EN 61131-2)		
Logic type		Sink/Source		
Input voltage range		24 Vdc		
Rated input voltage		19.2...28.8 Vdc		
Rated input current		7 mA		
Input impedance		3.4 kΩ		
Input limit values	Voltage at state 1	> 15 Vdc (15...28.8 Vdc)		
	Voltage at state 0	< 5 Vdc (0...5 Vdc)		
	Current at state 1	> 2.5 mA		
	Current at state 0	< 1.0 mA		
Derating		See derating curves, page 150		
Turn on time	I2, I3, I4, I5	35 μs + filter value ⁽¹⁾		
	I8...I23	100 μs + filter value ⁽¹⁾		
Turn off time	I2, I3, I4, I5	35 μs + filter value ⁽¹⁾		
	I8...I23	100 μs + filter value ⁽¹⁾		
Isolation	Between input and internal logic	500 Vac		
Connection type		Removable screw terminal blocks		
Connector insertion/removal durability		Over 100 times		
Cable	Type	Unshielded		
	Length	Maximum 30 m (98 ft)		
(1) For more information, refer to Integrator Filter Principle, page 48				

Fast Input Characteristics

The following table describes the characteristics of the TM221C Logic Controller fast inputs:

Characteristic		Value
Number of fast inputs		4 inputs (I0, I1, I6, I7)
Number of channel groups		1 common line
Input type		Type 1 (IEC/EN 61131-2)
Logic type		Sink/Source
Rated input voltage		24 Vdc
Input voltage range		19.2...28.8 Vdc
Rated input current		5 mA
Input impedance		4.9 kΩ
Input limit values	Voltage at state 1	> 15 Vdc (15...28.8 Vdc)
	Voltage at state 0	< 5 Vdc (0...5 Vdc)
	Current at state 1	> 2.6 mA
	Current at state 0	< 0.6 mA
Derating		See derating curves, page 150
Turn on time		5 μs + filter value ⁽¹⁾
Turn off time		5 μs + filter value ⁽¹⁾
HSC maximum frequency	Dual Phase	100 kHz
	Single phase	100 kHz
	Frequency Meter	100 kHz
Supported HSC operation mode		<ul style="list-style-type: none"> • Dual Phase [Pulse / Direction] • Dual Phase [Quadrature X1] • Dual Phase [Quadrature X2] • Dual Phase [Quadrature X4] • Single Phase • Frequency Meter
Isolation	Between input and internal logic	500 Vac
	Between channel groups	500 Vac
Connection type		Removable screw terminal block
Connector insertion/removal durability		Over 100 times
Cable	Type	Shielded, including the 24 Vdc power supply
	Length	Maximum 10 m (32.8 ft)
(1) For more information, refer to Integrator Filter Principle, page 48		

Derating Curves (No Cartridge)

The following figures show the derating curves of the embedded digital inputs for a configuration without cartridge:

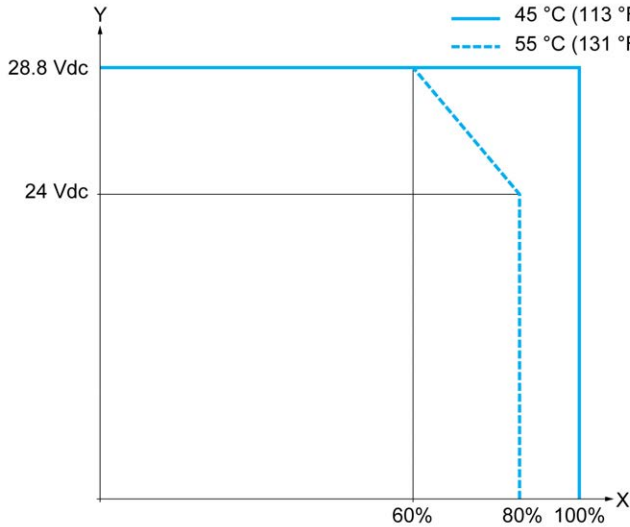

X Input simultaneous ON ratio
Y Input voltage

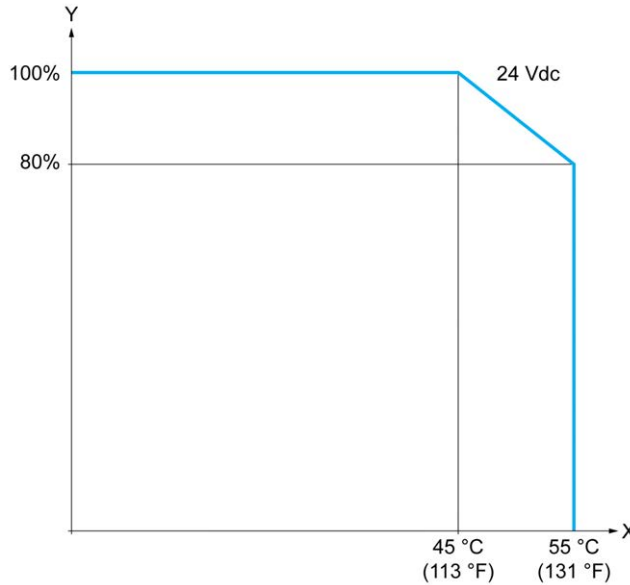

X Ambient temperature
Y Input simultaneous ON ratio

Derating Curves (with Cartridge)

The following figures show the derating curves of the embedded digital inputs for a configuration with cartridge:

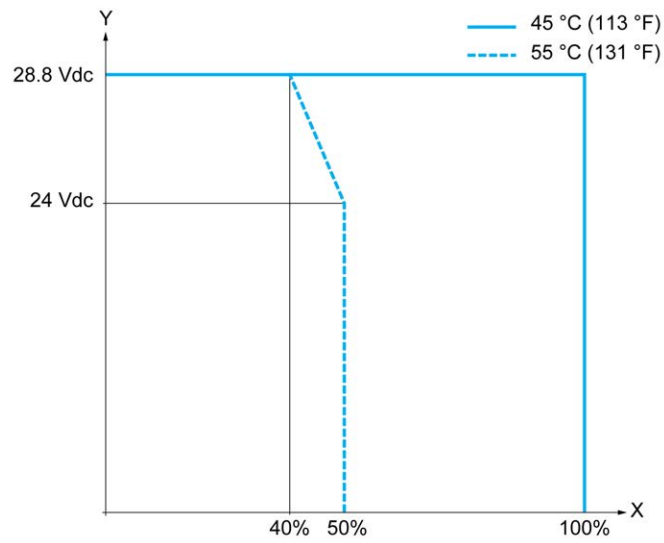

X Input simultaneous ON ratio

Y Input voltage

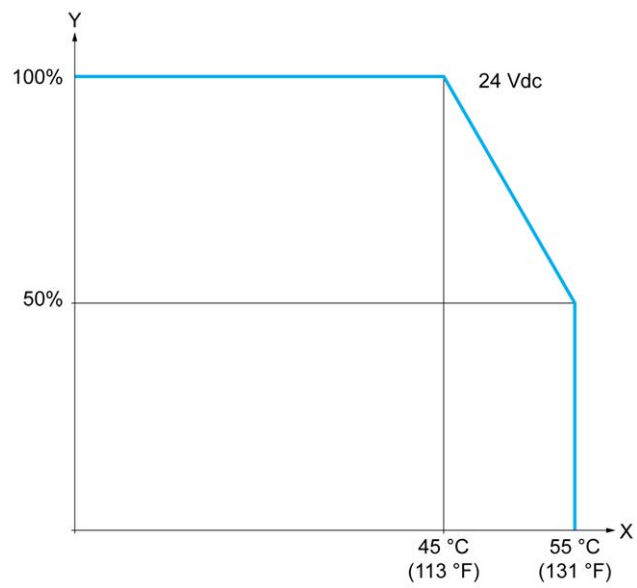

X Ambient temperature

Y Input simultaneous ON ratio

TM221C16R / TM221CE16R Wiring Diagrams

The following figure presents the sink wiring diagram (positive logic) of the inputs to the sensors for TM221C16R and TM221CE16R:

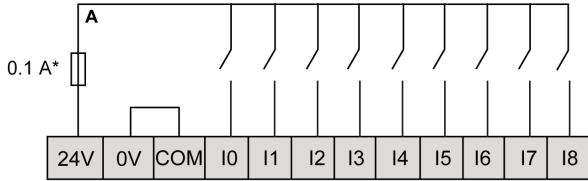

* Type T fuse

The following figure presents the source wiring diagram (negative logic) of the inputs to the sensors for TM221C16R and TM221CE16R:

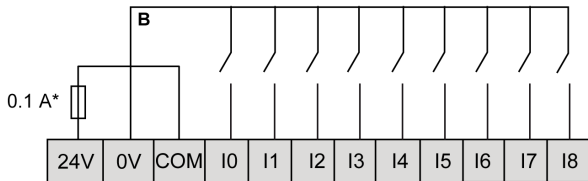

* Type T fuse

NOTE: The TM221C Logic Controller provides a 24 Vdc supply to the inputs.

The following figure presents the connection of the fast inputs:

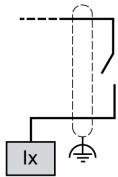

Ix I0, I1, I6, I7

TM221C24R / TM221CE24R Wiring Diagrams

The following figure presents the sink wiring diagram (positive logic) of the inputs to the sensors for TM221C24R and TM221CE24R:

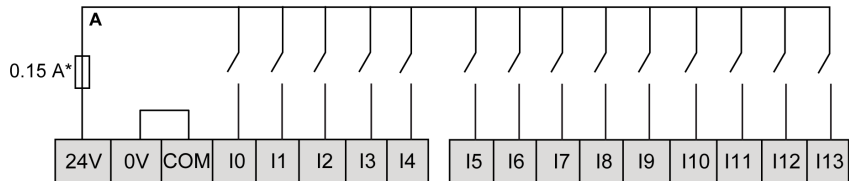

* Type T fuse

The following figure presents the source wiring diagram (negative logic) of the inputs to the sensors for TM221C24R and TM221CE24R:

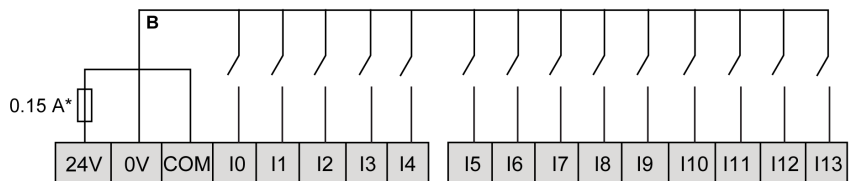

* Type T fuse

NOTE: The TM221C Logic Controller provides a 24 Vdc supply to the inputs.

The following figure presents the connection of the fast inputs:

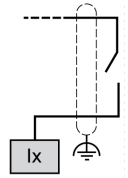

Ix I0, I1, I6, I7

TM221C40R / TM221CE40R Wiring Diagrams

The following figure presents the sink wiring diagram (positive logic) of the inputs to the sensors for TM221C40R and TM221CE40R:

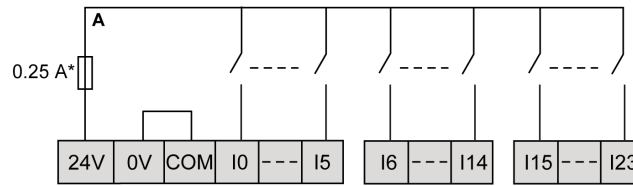

* Type T fuse

The following figure presents the source wiring diagram (negative logic) of the inputs to the sensors for TM221C40R and TM221CE40R:

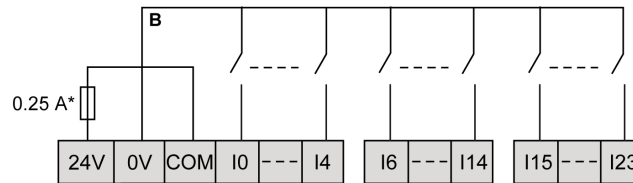

* Type T fuse

NOTE: The TM221C Logic Controller provides a 24 Vdc supply to the inputs.

The following figure presents the connection of the fast inputs:

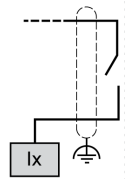

Ix I0, I1, I6, I7

TM221C••R / TM221CE••R Encoder Examples Wiring Diagrams

The following figures show four wiring examples for TM221C••R and TM221CE••R:

- dual-phase encoder without index
- dual-phase encoder with a limit switch and no index
- dual-phase encoder with index
- dual-phase encoder with index and PNP sensor

TM221C••R / TM221CE••R with a dual-phase encoder without index:

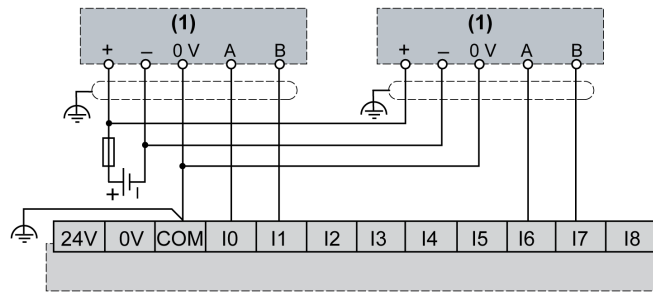

(1) Dual phase encoder without index

TM221C••R / TM221CE••R with a dual-phase encoder with a limit switch and no index:

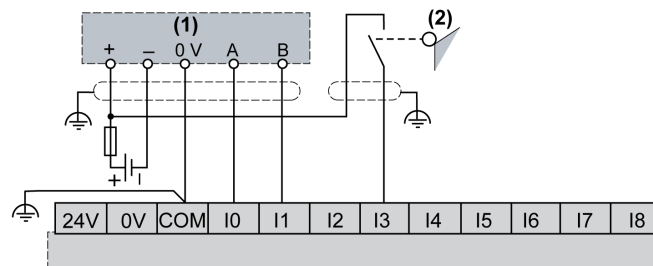

(1) Dual phase encoder without index

(2) Limit switch

TM221C••R / TM221CE••R with a dual-phase encoder with index:

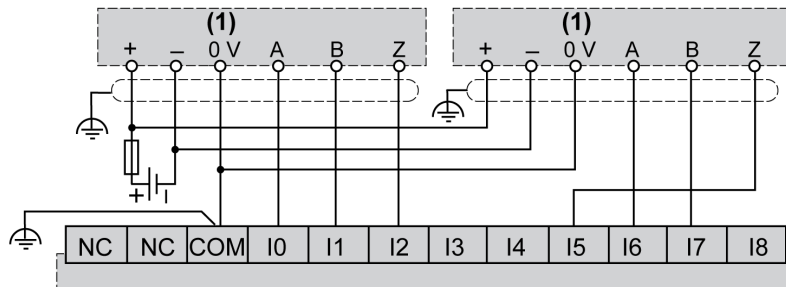

(1) Dual phase encoder with index

TM221C••R / TM221CE••R with a dual-phase encoder with index and PNP sensor:

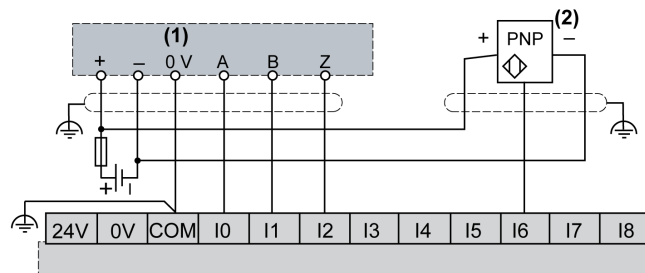

(1) Dual phase encoder with index

(2) PNP sensor

TM221C16T / TM221CE16T Wiring Diagrams

The following figure presents the connection of the inputs to the sensors for TM221C16T and TM221CE16T:

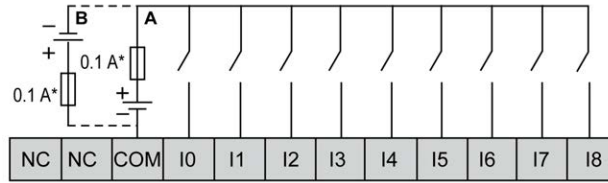

* Type T fuse

A Sink wiring (positive logic).

B Source wiring (negative logic).

The following figure presents the connection of the fast inputs:

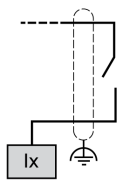

Ix 10, 11, 16, 17

⚠ WARNING

UNINTENDED EQUIPMENT OPERATION

Do not connect wires to unused terminals and/or terminals indicated as “No Connection (N.C.)”.

Failure to follow these instructions can result in death, serious injury, or equipment damage.

TM221C24T / TM221CE24T Wiring Diagrams

The following figure presents the connection of the inputs to the sensors for TM221C24T and TM221CE24T:

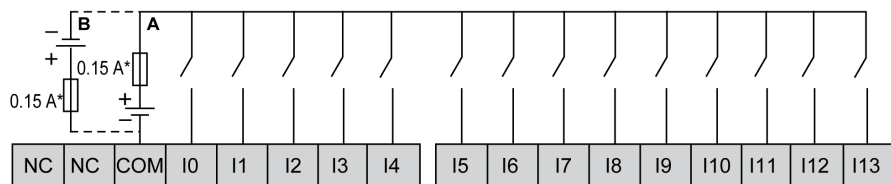

* Type T fuse

A Sink wiring (positive logic).

B Source wiring (negative logic).

The following figure presents the connection of the fast inputs:

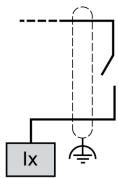

Ix I0, I1, I6, I7

⚠ WARNING
UNINTENDED EQUIPMENT OPERATION
Do not connect wires to unused terminals and/or terminals indicated as "No Connection (N.C.)".
Failure to follow these instructions can result in death, serious injury, or equipment damage.

TM221C40T / TM221CE40T Wiring Diagrams

The following figure presents the connection of the inputs to the sensors for TM221C40T and TM221CE40T:

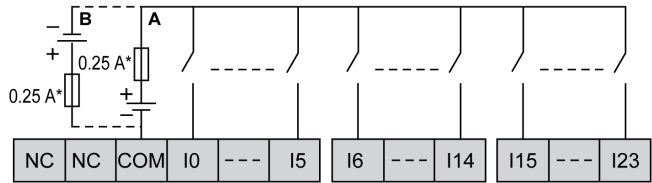

- * Type T fuse
- A** Sink wiring (positive logic).
- B** Source wiring (negative logic).

The following figure presents the connection of the fast inputs:

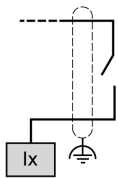

Ix I0, I1, I6, I7

⚠ WARNING
UNINTENDED EQUIPMENT OPERATION
Do not connect wires to unused terminals and/or terminals indicated as "No Connection (N.C.)".
Failure to follow these instructions can result in death, serious injury, or equipment damage.

TM221C••T / TM221CE••T Encoder Examples Wiring Diagrams

The following figures show four wiring examples for TM221C••T and TM221CE••T:

- dual-phase encoder without index
- dual-phase encoder with a limit switch and no index
- dual-phase encoder with index
- dual-phase encoder with index and PNP sensor

TM221C••T / TM221CE••T with a dual-phase encoder without index:

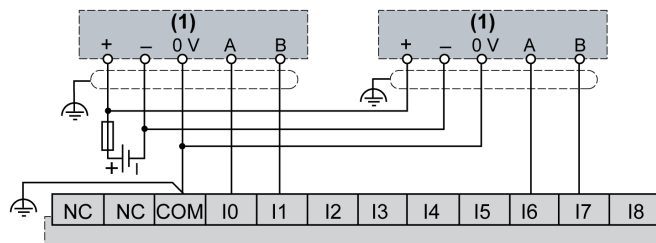

(1) Dual phase encoder without index

TM221C••T / TM221CE••T with a dual-phase encoder with a limit switch and no index:

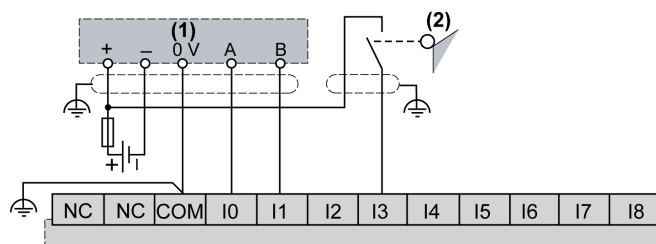

(1) Dual phase encoder without index

(2) Limit switch

TM221C••T / TM221CE••T with a dual-phase encoder with index:

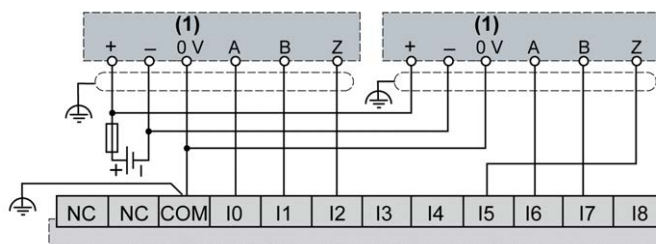

(1) Dual phase encoder with index

TM221C••T / TM221CE••T with a dual-phase encoder with index and PNP sensor:

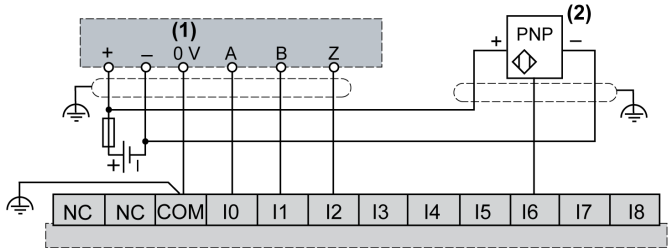

(1) Dual phase encoder with index

(2) PNP sensor

⚠ WARNING
UNINTENDED EQUIPMENT OPERATION
Do not connect wires to unused terminals and/or terminals indicated as "No Connection (N.C.)".
Failure to follow these instructions can result in death, serious injury, or equipment damage.

TM221C16U / TM221CE16U Wiring Diagrams

The following figure presents the connection of the inputs to the sensors for TM221C16U and TM221CE16U:

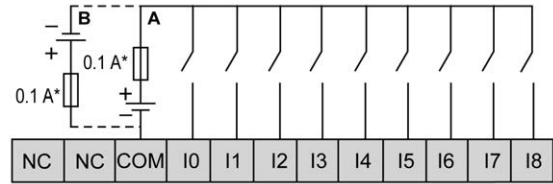

* Type T fuse

A Sink wiring (positive logic).

B Source wiring (negative logic).

The following figure presents the connection of the fast inputs:

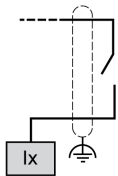

Ix I0, I1, I6, I7

⚠ WARNING
UNINTENDED EQUIPMENT OPERATION
Do not connect wires to unused terminals and/or terminals indicated as "No Connection (N.C.)".
Failure to follow these instructions can result in death, serious injury, or equipment damage.

TM221C24U / TM221CE24U Wiring Diagrams

The following figure presents the connection of the inputs to the sensors for TM221C24U and TM221CE24U:

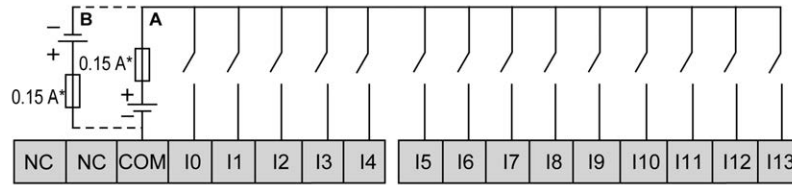

* Type T fuse

A Sink wiring (positive logic).

B Source wiring (negative logic).

The following figure presents the connection of the fast inputs:

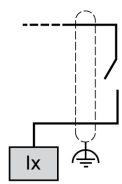

Ix I0, I1, I6, I7

⚠ WARNING

UNINTENDED EQUIPMENT OPERATION

Do not connect wires to unused terminals and/or terminals indicated as “No Connection (N.C.)”.

Failure to follow these instructions can result in death, serious injury, or equipment damage.

TM221C40U / TM221CE40U Wiring Diagrams

The following figure presents the connection of the inputs to the sensors for TM221C40U and TM221CE40U:

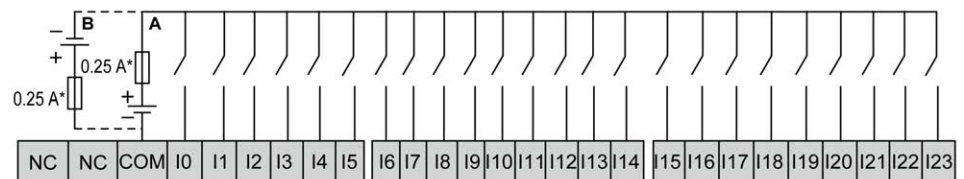

* Type T fuse

A Sink wiring (positive logic).

B Source wiring (negative logic).

The following figure presents the connection of the fast inputs:

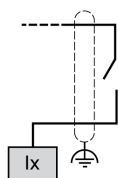

Ix I0, I1, I6, I7

⚠ WARNING	
UNINTENDED EQUIPMENT OPERATION	
Do not connect wires to unused terminals and/or terminals indicated as “No Connection (N.C.)”.	
Failure to follow these instructions can result in death, serious injury, or equipment damage.	

Relay Outputs

Overview

The Modicon TM221C Logic Controller has 7, 10 or 16 relay outputs embedded:

Reference	Number of relay outputs
TM221C16R / TM221CE16R	7
TM221C24R / TM221CE24R	10
TM221C40R / TM221CE40R	16

For more information, refer to Output Management, page 50.

⚠ DANGER	
FIRE HAZARD	
<ul style="list-style-type: none"> Use only the correct wire sizes for the maximum current capacity of the I/O channels and power supplies. For relay output (2 A) wiring, use conductors of at least 0.5 mm² (AWG 20) with a temperature rating of at least 80 °C (176 °F). For common conductors of relay output wiring (7 A), or relay output wiring greater than 2 A, use conductors of at least 1.0 mm² (AWG 16) with a temperature rating of at least 80 °C (176 °F). 	
Failure to follow these instructions will result in death or serious injury.	

⚠ WARNING	
UNINTENDED EQUIPMENT OPERATION	
Do not exceed any of the rated values specified in the environmental and electrical characteristics tables.	
Failure to follow these instructions can result in death, serious injury, or equipment damage.	

Relay Output Characteristics

The following table describes the characteristics of the TM221C Logic Controller with relay outputs:

Characteristic	Value		
	TM221C16R / TM221CE16R	TM221C24R / TM221CE24R	TM221C40R / TM221CE40R
Number of relay outputs	7 outputs	10 outputs	16 outputs
Number of channel groups	1 common line for Q0...Q3 1 common line for Q4...Q6	1 common line for Q0...Q3 1 common line for Q4...Q7 1 common line for Q8, Q9	1 common line for Q0...Q3 1 common line for Q4...Q7 1 common line for Q8...Q11 1 common line for Q12...Q15
Output type	Relay		
Contact type	NO (Normally Open)		
Rated output voltage	24 Vdc, 240 Vac		
Maximum voltage at 2 A	30 Vdc, 264 Vac		
Minimum switching load	5 Vdc at 10 mA		
Rated output current	2 A		
Maximum output current	2 A per output		
	7 A for common 0 (Q0...Q3) 6 A for common 1 (Q4...Q6)	7 A for common 0 (Q0...Q3) 7 A for common 1 (Q4...Q7) 4 A for common 2 (Q8, Q9)	7 A per common
Maximum output frequency with maximum load	20 operations per minute		
Derating	No derating		
Turn on time	Max. 10 ms		
Turn off time	Max. 10 ms		
Contact resistance	30 mΩ max		
Mechanical life	20 million operations		
Electrical life	Under resistive load	See power limitation, page 161	
	Under inductive load		
Protection against short circuit	No		
Isolation	Between output and internal logic	500 Vac	
	Between channel groups	500 Vac	
Connection type	Removable screw terminal blocks		
Connector insertion/removal durability	Over 100 times		
Cable	Type	Unshielded	
	Length	Max. 30 m (98 ft)	
NOTE: Refer to Protecting Outputs from Inductive Load Damage, page 78 for additional information concerning output protection.			

Power Limitation

The following table describes the power limitation of the relay outputs depending on the voltage, the type of load, and the number of operations required.

These controllers do not support capacitive loads.

⚠ WARNING

RELAY OUTPUTS WELDED CLOSED

- Always protect relay outputs from inductive alternating current load damage using an appropriate external protective circuit or device.
- Do not connect relay outputs to capacitive loads.

Failure to follow these instructions can result in death, serious injury, or equipment damage.

Power Limitations				
Voltage	24 Vdc	120 Vac	240 Vac	Number of operations
Power of resistive loads	–	240 VA	480 VA	100,000
AC-12		80 VA	160 VA	300,000
Power of inductive loads	–	60 VA	120 VA	100,000
AC-15 (cos ϕ = 0.35)		18 VA	36 VA	300,000
Power of inductive loads	–	120 VA	240 VA	100,000
AC-14 (cos ϕ = 0.7)		36 VA	72 VA	300,000
Power of resistive loads	48 W	–	–	100,000
DC-12	16 W			300,000
Power of inductive loads	24 W	–	–	100,000
DC-13 L/R = 7 ms	7.2 W			300,000

Relay Outputs Wiring Diagrams - Negative Logic (Sink)

The following figure presents the sink wiring diagram (negative logic) of the outputs to the load for the TM221C16R / TM221CE16R:

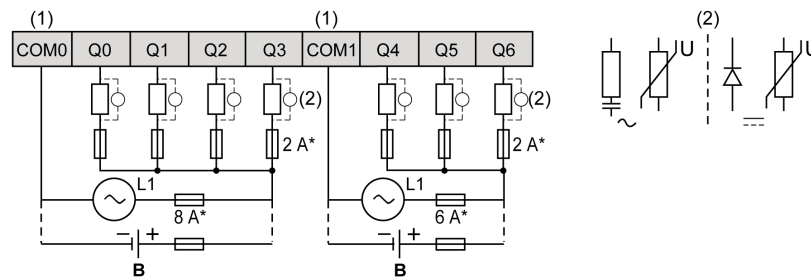

* Type T fuse

(1) The COM1 and COM2 terminals are **not** connected internally.

(2) To improve the life time of the contacts, and to protect from potential inductive load damage, you must connect a free wheeling diode in parallel to each inductive DC load or an RC snubber in parallel of each inductive AC load

B Sink wiring (negative logic)

The following figure presents the sink wiring diagram (negative logic) of the outputs to the load for the TM221C24R / TM221CE24R:

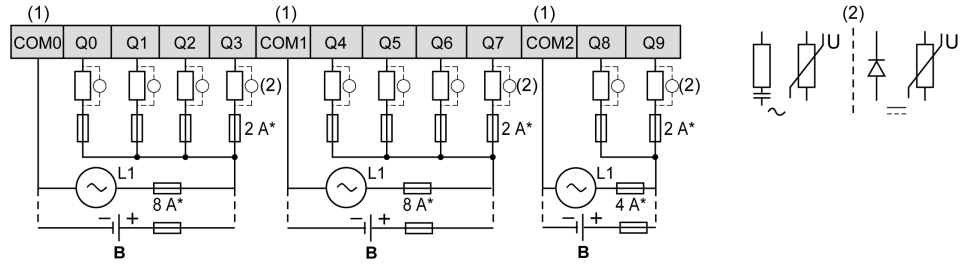

* Type T fuse

(1) The COM0, COM1 and COM2 terminals are **not** connected internally.

(2) To improve the life time of the contacts, and to protect from potential inductive load damage, you must connect a free wheeling diode in parallel to each inductive DC load or an RC snubber in parallel of each inductive AC load

B Sink wiring (negative logic)

The following figure presents the sink wiring diagram (negative logic) of the outputs to the load for the TM221C40R / TM221CE40R:

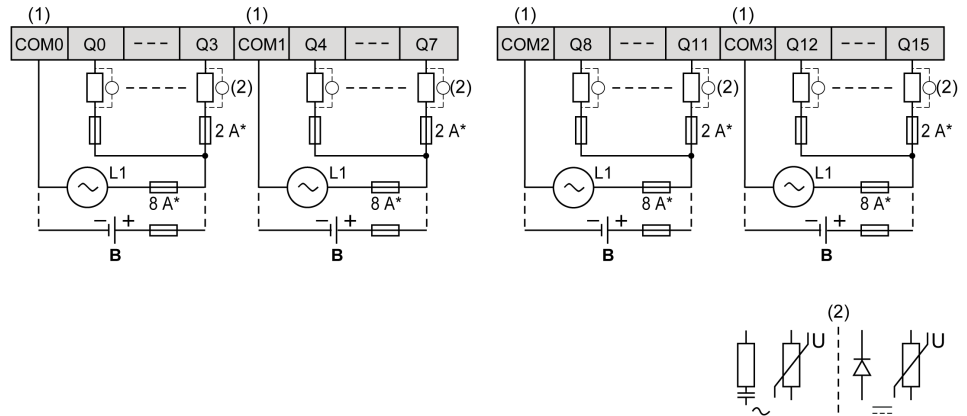

* Type T fuse

(1) The COM0, COM1, COM2 and COM3 terminals are **not** connected internally.

(2) To improve the life time of the contacts, and to protect from potential inductive load damage, you must connect a free wheeling diode in parallel to each inductive DC load or an RC snubber in parallel of each inductive AC load

B Sink wiring (negative logic)

NOTE: The assigned fuse values have been specified for the maximum current characteristics of the controller I/O and associated commons. You may have other considerations that are applicable based on the unique types of input and output devices you connect, and you should size your fuses accordingly.

Relay Outputs Wiring Diagrams - Positive Logic (Source)

The following figure presents the source wiring diagram (positive logic) of the outputs to the load for the TM221C16R / TM221CE16R:

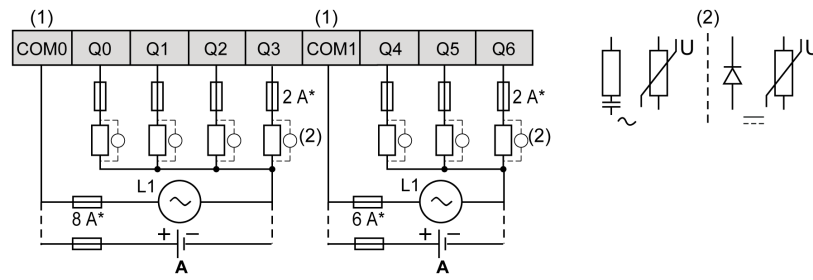

* Type T fuse

(1) The COM1 and COM2 terminals are **not** connected internally.

(2) To improve the life time of the contacts, and to protect from potential inductive load damage, you must connect a free wheeling diode in parallel to each inductive DC load or an RC snubber in parallel of each inductive AC load

A Source wiring (positive logic)

The following figure presents the source wiring diagram (positive logic) of the outputs to the load for the TM221C24R / TM221CE24R:

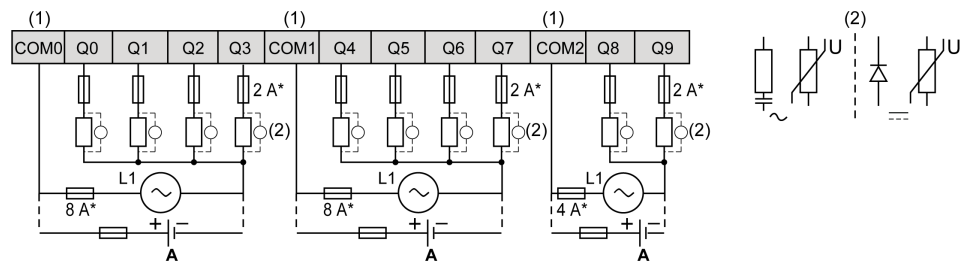

* Type T fuse

(1) The COM0, COM1 and COM2 terminals are **not** connected internally.

(2) To improve the life time of the contacts, and to protect from potential inductive load damage, you must connect a free wheeling diode in parallel to each inductive DC load or an RC snubber in parallel of each inductive AC load

A Source wiring (positive logic)

The following figure presents the source wiring diagram (positive logic) of the outputs to the load for the TM221C40R / TM221CE40R:

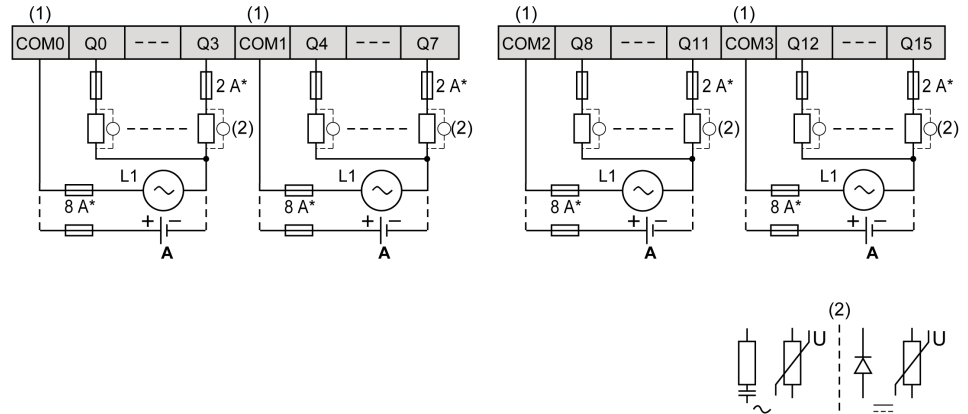

* Type T fuse

(1) The COM0, COM1, COM2 and COM3 terminals are **not** connected internally.

(2) To improve the life time of the contacts, and to protect from potential inductive load damage, you must connect a free wheeling diode in parallel to each inductive DC load or an RC snubber in parallel of each inductive AC load

A Source wiring (positive logic)

NOTE: The assigned fuse values have been specified for the maximum current characteristics of the controller I/O and associated commons. You may have other considerations that are applicable based on the unique types of input and output devices you connect, and you should size your fuses accordingly.

Regular and Fast Transistor Outputs

Overview

The Modicon TM221C Logic Controller has regular and fast transistor outputs embedded:

Reference	Total number of digital outputs	Transistor outputs	Fast outputs
TM221C16T / TM221CE16T	7	5	2
TM221C16U / TM221CE16U	7	5	2
TM221C24T / TM221CE24T	10	8	2
TM221C24U / TM221CE24U	10	8	2
TM221C40T / TM221CE40T	16	14	2
TM221C40U / TM221CE40U	16	12	4

For more information, refer to Output Management, page 50.

⚠ DANGER

FIRE HAZARD

- Use only the correct wire sizes for the maximum current capacity of the I/O channels and power supplies.
- For relay output (2 A) wiring, use conductors of at least 0.5 mm² (AWG 20) with a temperature rating of at least 80 °C (176 °F).
- For common conductors of relay output wiring (7 A), or relay output wiring greater than 2 A, use conductors of at least 1.0 mm² (AWG 16) with a temperature rating of at least 80 °C (176 °F).

Failure to follow these instructions will result in death or serious injury.

⚠ WARNING

UNINTENDED EQUIPMENT OPERATION

Do not exceed any of the rated values specified in the environmental and electrical characteristics tables.

Failure to follow these instructions can result in death, serious injury, or equipment damage.

Regular Transistor Output Characteristics

The following table describes the characteristics of the TM221C Logic Controller regular transistor outputs:

Characteristic	Value		
	TM221C16T / TM221CE16T / TM221C16U / TM221CE16U	TM221C24T / TM221CE24T / TM221C24U / TM221CE24U	TM221C40T / TM221CE40T / TM221C40U / TM221CE40U
Number of regular transistor outputs	5 outputs (Q2...Q6)	8 outputs (Q2...Q9)	14 outputs (Q2...Q15) (TM221C40T / TM221CE40T) 12 outputs (Q4...Q15) (TM221C40U / TM221CE40U)
Number of channel groups	1 common line for Q0...Q6	1 common line for Q0...Q9	1 common line for Q0...Q7 1 common line for Q8...Q15
Output type	Transistor		
Logic type	Source for TM221...T Sink for TM221...U		
Rated output voltage	24 Vdc		
Output voltage range	19.2...28.8 Vdc		
Rated output current	0.5 A		
Total output current	3.5 A for channel group Q0... Q6	5 A for channel group Q0...Q9	4 A for channel group Q0... Q7 4 A for channel group Q8... Q15
Voltage drop	1 Vdc max		
Leakage current when switched off	0.1 mA		
Maximum power of filament lamp	12 W max		
Derating	See derating curves, page 169		
Turn on time	Q2, Q3	Max. 50 µs	
	Other regular outputs	Max. 300 µs	
Turn off time	Q2, Q3	Max. 50 µs	
	Other regular outputs	Max. 300 µs	
Protection against short circuit	Yes (TM221C...T only)		
Short circuit output peak current	1.3 A		
Automatic rearming after short circuit or overload	Yes, every 1 s		
Clamping voltage	Max. 39 Vdc ± 1 Vdc		
Switching frequency	Under resistive load	100 Hz max.	
Isolation	Between output and internal logic	500 Vac	
Connection type	Removable screw terminal blocks		
Connector insertion/removal durability	Over 100 times		
Cable	Type	Unshielded	
	Length	Max 30 m (98 ft)	
NOTE: Refer to Protecting Outputs from Inductive Load Damage, page 78 for additional information concerning output protection.			

Fast Transistor Output Characteristics

The following table describes the characteristics of the TM221C Logic Controller fast transistor outputs:

Characteristic		Value
Number of fast transistor outputs		2 fast outputs (Q0, Q1) 4 fast outputs (Q0, Q1, Q2 and Q3) for TM221•••40U
Number of channel groups		1 common line
Output type		Transistor
Logic type		Source for TM221•••T Sink for TM221•••U
Rated output voltage		24 Vdc
Output voltage range		19.2...28.8 Vdc
Rated output current		0.5 A
Total output current	TM221C16T / TM221CE16T TM221C16U / TM221CE16U	3.5 A for channel group Q0...Q6
	TM221C24T / TM221CE24T TM221C24U / TM221CE24U	5 A for channel group Q0...Q9
	TM221C40T / TM221CE40T	4 A for channel group Q0...Q7
	TM221C40U / TM221CE40U	4 A for channel group Q8...Q15
Maximum power of filament lamp		12 W max
Derating		See derating curves, page 169
Turn on time (10 mA < output current < 100 mA)		Max. 5 μ s
Turn off time (10 mA < output current < 100 mA)		Max. 5 μ s
Protection against short circuit		Yes (TM221C•••T only)
Short circuit output peak current		1.3 A max.
Automatic rearming after short circuit or overload		Yes, every 1 s
Protection against reverse polarity		Yes
Clamping voltage		Typ. 39 Vdc +/- 1 Vdc
Maximum output frequency	PLS/PWM/PTO/FREQGEN	100 kHz
Isolation	Between output and internal logic	500 Vac
Connection type		Removable screw terminal blocks
Connector insertion/removal durability		Over 100 times
Cable	Type	Shielded, including 24 Vdc power supply
	Length	Maximum 3 m (9.84 ft)
<p>NOTE: Refer to Protecting Outputs from Inductive Load Damage, page 78 for additional information concerning output protection.</p>		

Derating Curves (No Cartridge)

The following figures show the derating curves of the embedded digital outputs for a configuration without cartridge:

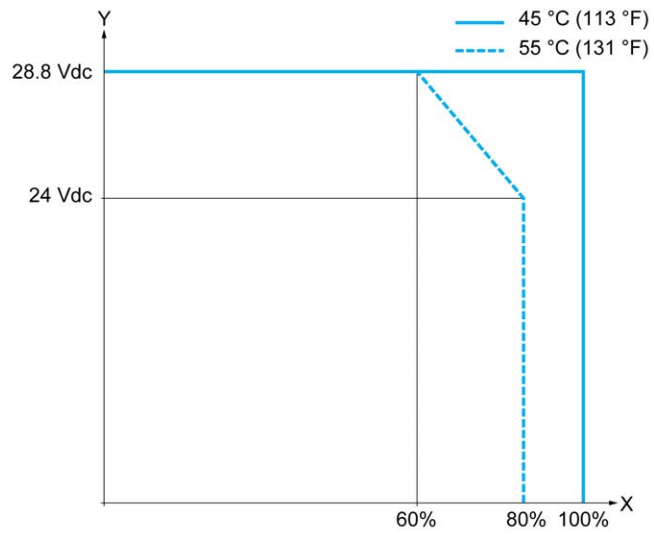

X Output simultaneous ON ratio

Y Output voltage

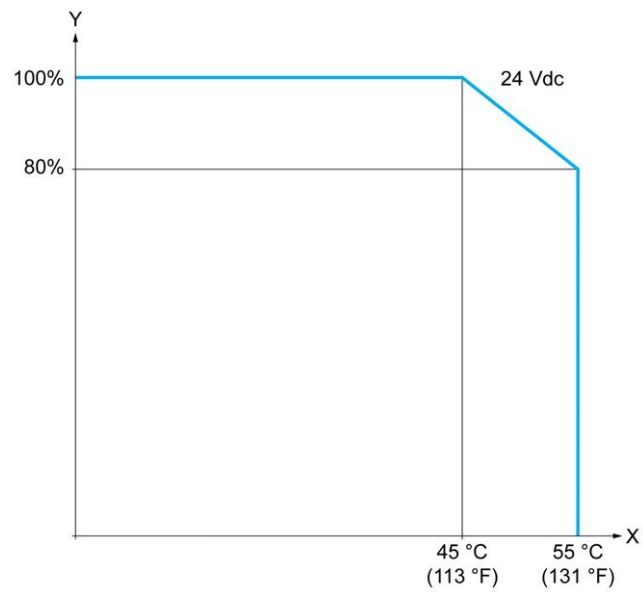

X Ambient temperature

Y Output simultaneous ON ratio

Derating Curves (with Cartridge)

The following figures show the derating curves of the embedded digital outputs for a configuration with cartridge:

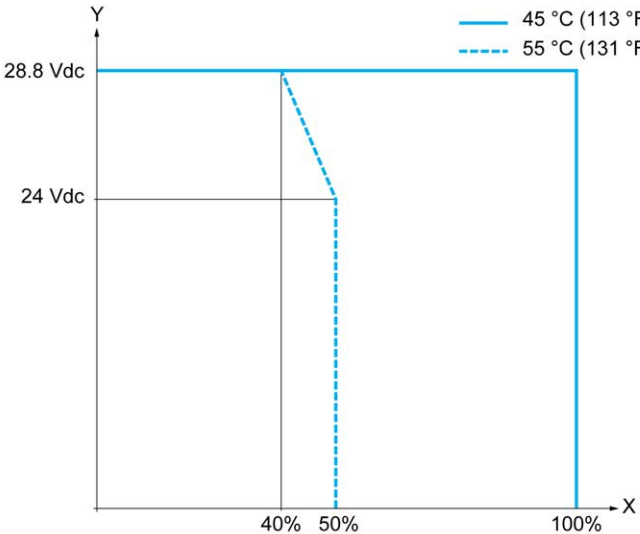

X Output simultaneous ON ratio

Y Output voltage

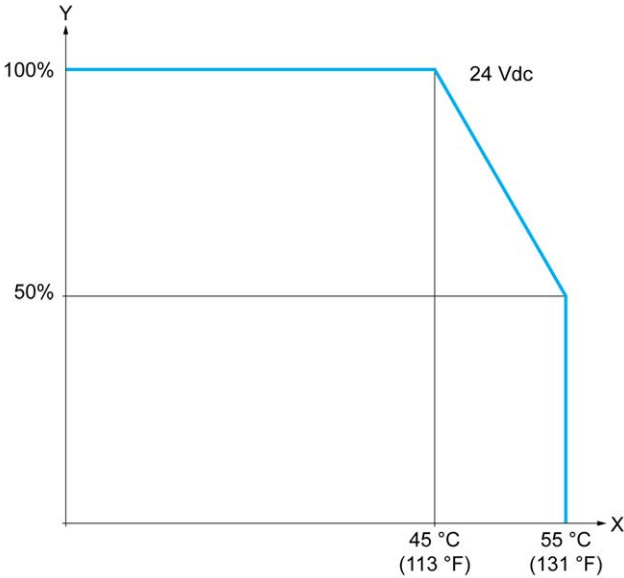

X Ambient temperature

Y Output simultaneous ON ratio

Transistor Outputs Wiring Diagrams

The following figure presents the connection of the outputs to the load for the TM221C16T / TM221CE16T:

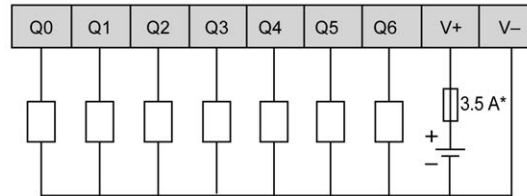

* Type T fuse

The following figure presents the connection of the fast outputs:

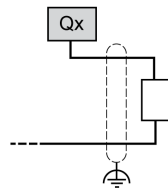

Qx Q0, Q1

The following figure presents the connection of the outputs to the load for the TM221C24T / TM221CE24T:

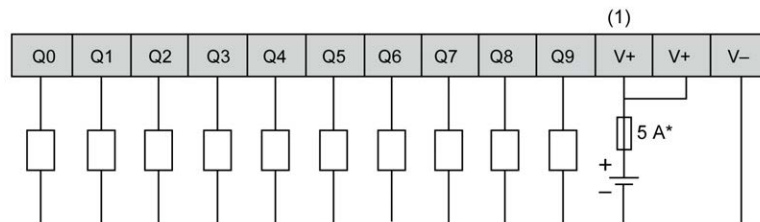

* Type T fuse

(1) The V+ terminals are connected internally.

The following figure presents the connection of the fast outputs:

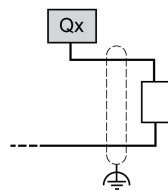

Qx Q0, Q1

The following figure presents the connection of the outputs to the load for the TM221C40T / TM221CE40T:

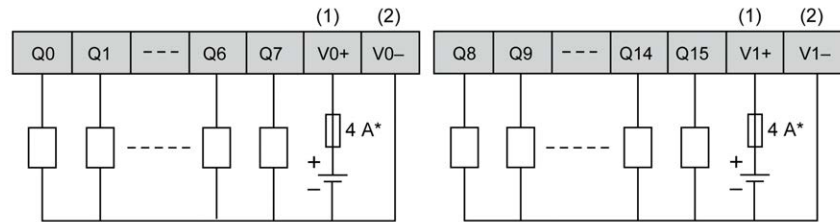

* Type T fuse

(1) The V0+ and V1+ terminals are **not** connected internally.

(2) The V0- and V1- terminals are **not** connected internally.

The following figure presents the connection of the fast outputs:

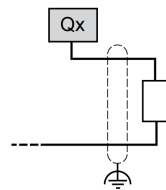

Qx Q0, Q1

Sink Transistor Outputs Wiring Diagrams

The following figure presents the connection of the outputs to the load for the TM221C16U / TM221CE16U:

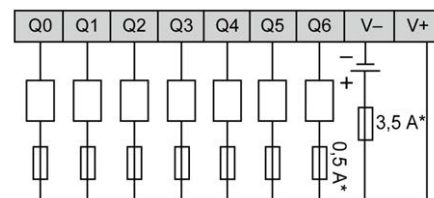

* Type T fuse

The following figure presents the connection of the fast outputs:

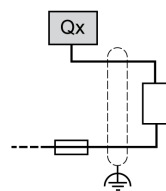

Qx Q0, Q1

The following figure presents the connection of the outputs to the load for the TM221C24U / TM221CE24U:

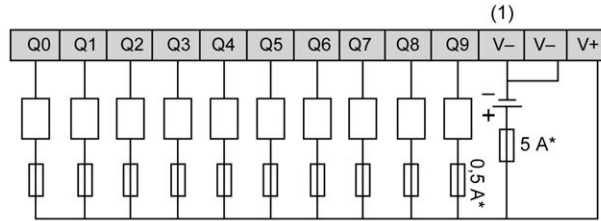

* Type T fuse

(1) The V- terminals are connected internally.

The following figure presents the connection of the fast outputs:

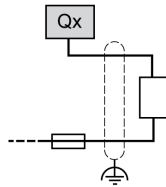

Qx Q0, Q1

The following figure presents the connection of the outputs to the load for the TM221C40U / TM221CE40U:

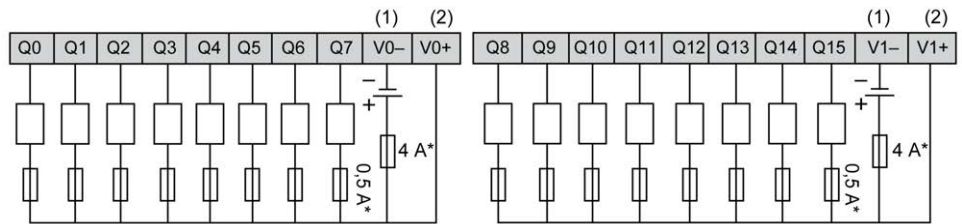

* Type T fuse

(1) The V0- and V1- terminals are **not** connected internally.

(2) The V0+ and V1+ terminals are **not** connected internally.

The following figure presents the connection of the fast outputs:

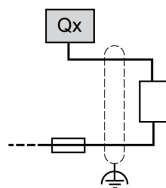

Qx Q0, Q1, Q2, Q3

Analog Inputs

Overview

The Modicon M221 Logic Controller has 2 analog inputs embedded.

⚠ DANGER

FIRE HAZARD

- Use only the correct wire sizes for the maximum current capacity of the I/O channels and power supplies.
- For relay output (2 A) wiring, use conductors of at least 0.5 mm² (AWG 20) with a temperature rating of at least 80 °C (176 °F).
- For common conductors of relay output wiring (7 A), or relay output wiring greater than 2 A, use conductors of at least 1.0 mm² (AWG 16) with a temperature rating of at least 80 °C (176 °F).

Failure to follow these instructions will result in death or serious injury.

⚠ WARNING

UNINTENDED EQUIPMENT OPERATION

Do not exceed any of the rated values specified in the environmental and electrical characteristics tables.

Failure to follow these instructions can result in death, serious injury, or equipment damage.

Mounting the Analog Cables

The following procedure describes how to mount the analog cables:

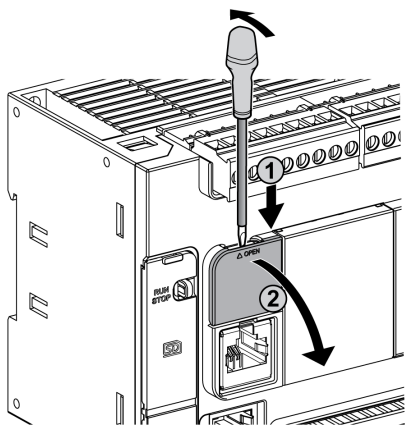
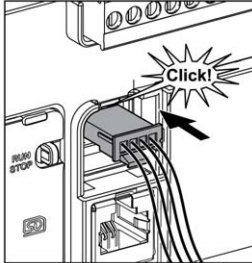
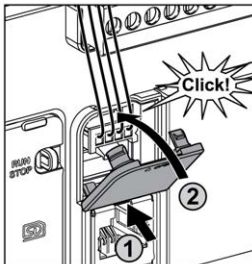
Step	Action
1	<p>Use a screw-driver to remove the protective cover.</p> 
2	<p>Push until you hear it "click".</p> 
3	<p>Replace the protective cover.</p> 

Analog Input Characteristics

The following table describes the characteristics of the M221 Logic Controller with analog inputs:

Characteristic		Voltage Input
Number of maximum inputs		2 inputs
Input type		Single-ended
Rated input range		0...+10 Vdc
Digital resolution		10 bits
Input value of LSB		10 mV
Input impedance		100 kΩ
Input delay time		12 ms
Sample duration time		1 ms per channel + 1 scan time
Accuracy		± 1 % of the full scale
Noise resistance - maximum temporary deviation during perturbations		± 5 % maximum of the full scale when EMC perturbation is applied to the power and I/O wiring
Isolation	Between input and internal logic	Not isolated
Connection type		Specific connector and cable (supplied)
Connector insertion/removal durability		Over 100 times
Cable	Type	Proprietary (supplied)
	Length	1 m (3.3 ft)

Analog Inputs Wiring Diagram

The following figure shows the wiring diagram of the M221 Logic Controller analog inputs:

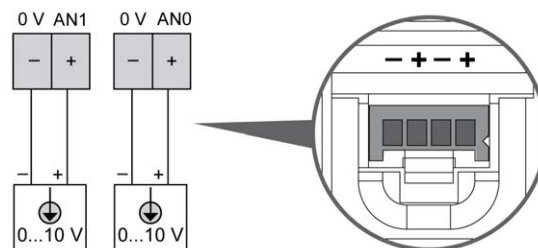

The (-) poles are connected internally.

Pin	Wire Color
0 V	Black
AN1	Red
0 V	Black
AN0	Red

For more information, refer to the Wiring Best Practices, page 74.

Modicon TM221M Logic Controller

What's in This Part

TM221M16R / TM221M16RG	178
TM221ME16R / TM221ME16RG	190
TM221M16T / TM221M16TG	202
TM221ME16T / TM221ME16TG	216
TM221M32TK	229
TM221ME32TK	242

TM221M16R / TM221M16RG

What's in This Chapter

TM221M16R / TM221M16RG Presentation	178
TM221M16R / TM221M16RG Digital Inputs	181
TM221M16R / TM221M16RG Digital Outputs	184
TM221M16R / TM221M16RG Analog Inputs	187

Overview

This chapter describes the TM221M16R / TM221M16RG controllers.

TM221M16R / TM221M16RG Presentation

Overview

The following features are integrated into the TM221M16R (screw) and TM221M16RG (spring) controllers:

- 8 digital inputs
 - 4 regular inputs
 - 4 fast inputs (HSC)
- 8 digital outputs
 - 8 relay outputs
- 2 analog inputs
- Communication port
 - 2 serial line ports
 - 1 USB mini-B programming port

Description

The following figure shows the different components of the controllers:

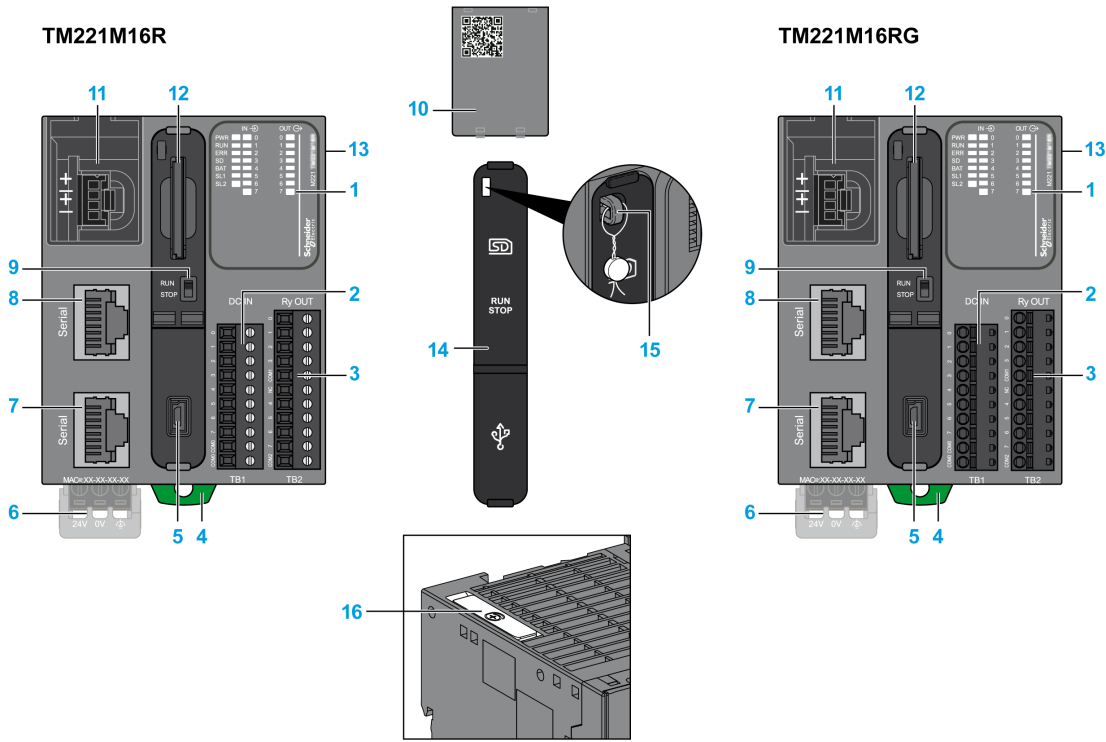

N°	Description	Refer to
1	Status LEDs	–
2	Input removable terminal block	Rules for Removable Screw Terminal Block, page 76
3	Output removable terminal block	Rules for Removable Spring Terminal Block, page 77
4	Clip-on lock for 35 mm (1.38 in.) top hat section rail (DIN-rail)	DIN Rail
5	USB mini-B programming port / For terminal connection to a programming PC (EcoStruxure Machine Expert - Basic)	USB mini-B programming port , page 257
6	24 Vdc power supply	Power supply, page 79
7	Serial line port 2 / RJ45 connector (RS-485)	Serial line 2, page 263
8	Serial line port 1 / RJ45 connector (RS-232 or RS-485)	Serial line 1, page 260
9	Run/Stop switch	Run/Stop switch , page 53
10	Removable analog inputs cover	–
11	2 analog inputs	Analog Inputs, page 187
12	SD Card slot	SD Card Slot, page 55
13	I/O expansion connector	–
14	Protective cover (SD Card slot, Run/Stop switch and USB mini-B programming port)	–
15	Locking hook	–
16	Battery holder	Installing and Replacing the Battery, page 45

Status LEDs

The following figure shows the status LEDs:

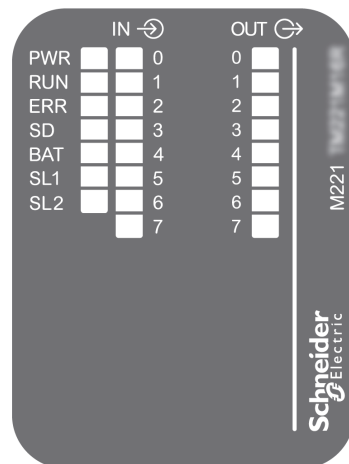

The following table describes the status LEDs:

Label	Function Type	Color	Status	Description		
				Controller States ⁽¹⁾	Prg Port Communication	Application Execution
PWR	Power	Green	On	Indicates that power is applied.		
			Off	Indicates that power is removed.		
RUN	Machine Status	Green	On	Indicates that the controller is running a valid application.		
			Flashing	Indicates that the controller has a valid application that is stopped.		
			Off	Indicates that the controller is not programmed.		
ERR	Error	Red	On*	EXCEPTION	Restricted	NO
			Flashing (with RUN status LED Off)	INTERNAL ERROR	Restricted	NO
			Slow flashing	Minor error detected ⁽²⁾	Yes	Depends on the RUN status LED
			1 single flash	No application	Yes	Yes
SD	SD Card Access, page 55	Green	On	Indicates that the SD card is being accessed.		
			Flashing	Indicates that an error was detected during the SD card operation.		
			Off	Indicates no access (idle) or no card is present.		
BAT	Battery, page 44	Red	On	Indicates that the battery needs to be replaced.		
			Flashing	Indicates that the battery charge is low.		
			Off	Indicates that the battery is OK.		
SL1	Serial line 1, page 260	Green	On	Indicates the status of Serial line 1.		
			Flashing	Indicates activity on Serial line 1.		
			Off	Indicates no serial communication.		
SL2	Serial line 2, page 263	Green	On	Indicates the status of Serial line 2.		
			Flashing	Indicates activity on Serial line 2.		
			Off	Indicates no serial communication.		

Label	Function Type	Color	Status	Description		
				Controller States ⁽¹⁾	Prg Port Communication	Application Execution
* ERR LED is also On during booting process.						
(1) For more information about the controller state description, refer to the M221 Logic Controller - Programming Guide (see Modicon M221, Logic Controller, Programming Guide).						
(2) The controller detected an error but remains in RUNNING state. The ERR LED on the controller flashes. For more information, refer to M221 Logic Controller - Programming Guide.						

Dimensions

The following figure shows the external dimensions of the controllers:

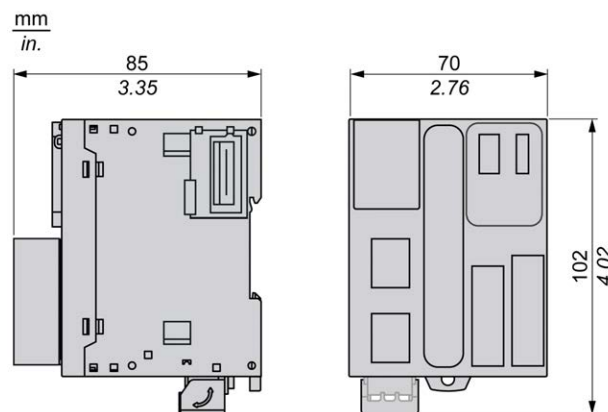

TM221M16R / TM221M16RG Digital Inputs

Overview

This M221 Logic Controller has embedded digital inputs:

- 4 regular inputs
- 4 fast inputs which can be used as 100 kHz HSC inputs

For more information, refer to Input Management, page 48.

⚠ DANGER

FIRE HAZARD

- Use only the correct wire sizes for the maximum current capacity of the I/O channels and power supplies.
- For relay output (2 A) wiring, use conductors of at least 0.5 mm² (AWG 20) with a temperature rating of at least 80 °C (176 °F).
- For common conductors of relay output wiring (7 A), or relay output wiring greater than 2 A, use conductors of at least 1.0 mm² (AWG 16) with a temperature rating of at least 80 °C (176 °F).

Failure to follow these instructions will result in death or serious injury.

⚠ WARNING**UNINTENDED EQUIPMENT OPERATION**

Do not exceed any of the rated values specified in the environmental and electrical characteristics tables.

Failure to follow these instructions can result in death, serious injury, or equipment damage.

Regular Input Characteristics

The following table describes the characteristics of the TM221M Logic Controller regular inputs:

Characteristic		Value
Number of regular inputs		4 inputs (I2, I3, I4, I5)
Number of channel groups		1 common line for I0...I7
Input type		Type 1 (IEC/EN 61131-2)
Logic type		Sink/Source
Input voltage range		24 Vdc
Rated input voltage		19.2...28.8 Vdc
Rated input current		7 mA
Input impedance		3.4 kΩ
Input limit values	Voltage at state 1	> 15 Vdc (15...28.8 Vdc)
	Voltage at state 0	< 5 Vdc (0...5 Vdc)
	Current at state 1	> 2.5 mA
	Current at state 0	< 1.0 mA
Derating		No derating
Turn on time		35 μs + filter value ⁽¹⁾
Turn off time		35 μs + filter value ⁽¹⁾
Isolation	Between input and internal logic	500 Vac
Connection type	TM221M16R	Removable screw terminal blocks
	TM221M16RG	Removable spring terminal blocks
Connector insertion/removal durability		Over 100 times
Cable	Type	Unshielded
	Length	Maximum 30 m (98 ft)
(1) For more information, refer to Integrator Filter Principle, page 48		

Fast Input Characteristics

The following table describes the characteristics of the TM221M Logic Controller fast inputs:

Characteristic		Value
Number of fast inputs		4 inputs (I0, I1, I6, I7)
Number of channel groups		1 common line for I0...I7
Input type		Type 1 (IEC/EN 61131-2)
Logic type		Sink/Source
Rated input voltage		24 Vdc
Input voltage range		19.2...28.8 Vdc
Rated input current		4.5 mA
Input impedance		4.9 kΩ
Input limit values	Voltage at state 1	> 15 Vdc (15...28.8 Vdc)
	Voltage at state 0	< 5 Vdc (0...5 Vdc)
	Current at state 1	> 2.5 mA
	Current at state 0	< 1.0 mA
Derating		No derating
Turn on time		5 μs + filter value ⁽¹⁾
Turn off time		5 μs + filter value ⁽¹⁾
HSC maximum frequency	Dual Phase	100 kHz
	Single phase	100 kHz
	Frequency Meter	100 kHz
HSC supported operation mode		<ul style="list-style-type: none"> • Dual Phase [Pulse / Direction] • Dual Phase [Quadrature X1] • Dual Phase [Quadrature X2] • Dual Phase [Quadrature X4] • Single Phase • Frequency Meter
Isolation	Between input and internal logic	500 Vac
Connection type	TM221M16R	Removable screw terminal block
	TM221M16RG	Removable spring terminal block
Connector insertion/removal durability		Over 100 times
Cable	Type	Shielded, including the 24 Vdc power supply
	Length	Maximum 10 m (32.8 ft)
(1) For more information, refer to Integrator Filter Principle, page 48		

Wiring Diagram

The following figure presents the connection of the inputs to the sensors:

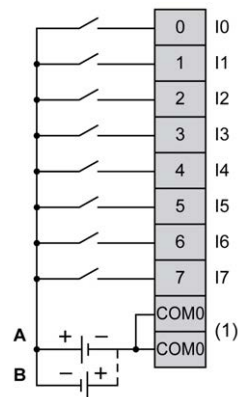

(1) The COM0 terminals are connected internally.

A Sink wiring (positive logic).

B Source wiring (negative logic).

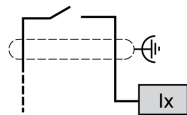

Ix I0, I1, I6, I7

TM221M16R / TM221M16RG Digital Outputs

Overview

M221 Logic Controller with 8 relay outputs embedded.

For more information on Output Management, page 50.

⚠ DANGER

FIRE HAZARD

- Use only the correct wire sizes for the maximum current capacity of the I/O channels and power supplies.
- For relay output (2 A) wiring, use conductors of at least 0.5 mm² (AWG 20) with a temperature rating of at least 80 °C (176 °F).
- For common conductors of relay output wiring (7 A), or relay output wiring greater than 2 A, use conductors of at least 1.0 mm² (AWG 16) with a temperature rating of at least 80 °C (176 °F).

Failure to follow these instructions will result in death or serious injury.

⚠ WARNING

UNINTENDED EQUIPMENT OPERATION

Do not exceed any of the rated values specified in the environmental and electrical characteristics tables.

Failure to follow these instructions can result in death, serious injury, or equipment damage.

Relay Output Characteristics

The following table describes the characteristics of the TM221M Logic Controller with relay outputs:

Characteristic		Value
Number of relay outputs		8 outputs
Number of channel groups		1 common line for Q0...Q3 1 common line for Q4...Q7
Output type		Relay
Contact type		NO (Normally Open)
Rated output voltage		24 Vdc, 240 Vac
Maximum voltage at 2 A		30 Vdc, 264 Vac
Minimum switching load		5 Vdc at 10 mA
Rated output current		2 A
Maximum output current		2 A per output
		7 A per common
Maximum output frequency with maximum load		20 operations per minute
Derating		No derating
Turn on time		Max. 10 ms
Turn off time		Max. 10 ms
Contact resistance		30 mΩ max
Mechanical life		20 million operations
Electrical life	Under resistive load	See power limitation, page 185
	Under inductive load	
Protection against short circuit		No
Isolation	Between output and internal logic	500 Vac
	Between channel groups	500 Vac
Connection type	TM221M16R	Removable screw terminal blocks
	TM221M16RG	Removable spring terminal blocks
Connector insertion/removal durability		Over 100 times
Cable	Type	Unshielded
	Length	Max. 30 m (98 ft)
<p>NOTE: Refer to Protecting Outputs from Inductive Load Damage, page 78 for additional information concerning output protection.</p>		

Power Limitation

The following table describes the power limitation of the TM221M16R / TM221M16RG relay outputs depending on the voltage, the type of load, and the number of operations required.

These controllers do not support capacitive loads.

⚠ WARNING

RELAY OUTPUTS WELDED CLOSED

- Always protect relay outputs from inductive alternating current load damage using an appropriate external protective circuit or device.
- Do not connect relay outputs to capacitive loads.

Failure to follow these instructions can result in death, serious injury, or equipment damage.

Power Limitations				
Voltage	24 Vdc	120 Vac	240 Vac	Number of operations
Power of resistive loads	–	240 VA	480 VA	100,000
AC-12		80 VA	160 VA	300,000
Power of inductive loads	–	60 VA	120 VA	100,000
AC-15 (cos φ = 0.35)		18 VA	36 VA	300,000
Power of inductive loads	–	120 VA	240 VA	100,000
AC-14 (cos φ = 0.7)		36 VA	72 VA	300,000
Power of resistive loads	48 W	–	–	100,000
DC-12	16 W			300,000
Power of inductive loads	24 W	–	–	100,000
DC-13 L/R = 7 ms	7.2 W			300,000

Wiring Diagram

The following figure presents the connection of the outputs to the load:

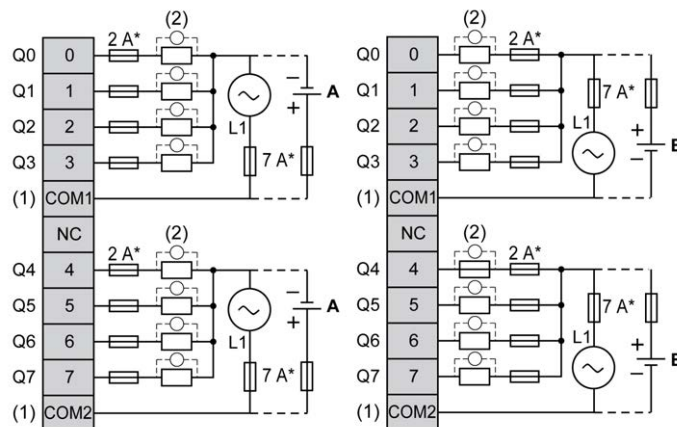

* Type T fuse

(1) The COM1 and COM2 terminals are **not** connected internally.

(2) To improve the life time of the contacts, and to protect from potential inductive load damage, you must connect a free wheeling diode in parallel to each inductive DC load or an RC snubber in parallel of each inductive AC load

A Source wiring (positive logic).

B Sink wiring (negative logic).

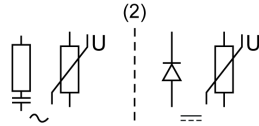

NOTE: The assigned fuse values have been specified for the maximum current characteristics of the controller I/O and associated commons. You may have other considerations that are applicable based on the unique types of input and output devices you connect, or conformance to local, national or applicable certification regulations and standards, and you should size your fuses accordingly.

⚠ WARNING
UNINTENDED EQUIPMENT OPERATION
Do not connect wires to unused terminals and/or terminals indicated as “No Connection (N.C.)”.
Failure to follow these instructions can result in death, serious injury, or equipment damage.

TM221M16R / TM221M16RG Analog Inputs

Overview

The M221 Logic Controllers have 2 analog inputs embedded.

⚠ DANGER
FIRE HAZARD
<ul style="list-style-type: none"> • Use only the correct wire sizes for the maximum current capacity of the I/O channels and power supplies. • For relay output (2 A) wiring, use conductors of at least 0.5 mm² (AWG 20) with a temperature rating of at least 80 °C (176 °F). • For common conductors of relay output wiring (7 A), or relay output wiring greater than 2 A, use conductors of at least 1.0 mm² (AWG 16) with a temperature rating of at least 80 °C (176 °F).
Failure to follow these instructions will result in death or serious injury.

⚠ WARNING
UNINTENDED EQUIPMENT OPERATION
Do not exceed any of the rated values specified in the environmental and electrical characteristics tables.
Failure to follow these instructions can result in death, serious injury, or equipment damage.

The following procedure describes how to mount the analog cables:

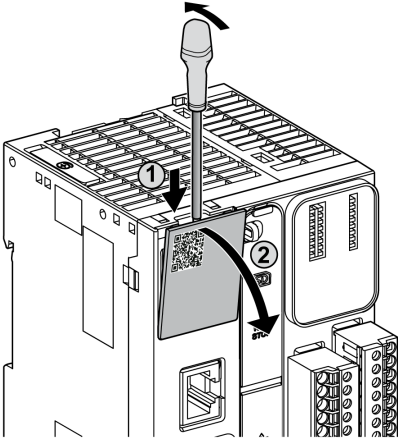
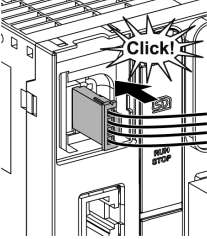
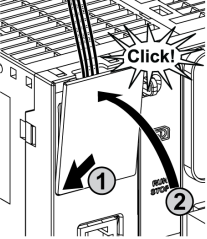
Step	Action
1	Use a screw-driver to remove the protective cover. 
2	Push until you hear it "click". 
3	Replace the protective cover. 

Analog Input Characteristics

The following table describes the characteristics of the M221 Logic Controller with analog inputs:

Characteristic	Voltage Input
Number of maximum inputs	2 inputs
Input type	Single-ended
Rated input range	0...+10 Vdc
Digital resolution	10 bits
Input value of LSB	10 mV
Input impedance	100 k Ω
Input delay time	12 ms
Sample duration time	1 ms per channel + 1 scan time
Accuracy	$\pm 1\%$ of the full scale

Characteristic		Voltage Input
Noise resistance - maximum temporary deviation during perturbations		± 5 % maximum of the full scale when EMC perturbation is applied to the power and I/O wiring
Isolation	Between input and internal logic	Not isolated
Connection type		Specific connector and cable (supplied)
Connector insertion/removal durability		Over 100 times
Cable	Type	Proprietary (supplied)
	Length	1 m (3.3 ft)

Wiring Diagram

The following figure shows the wiring diagram of the M221 Logic Controller analog inputs:

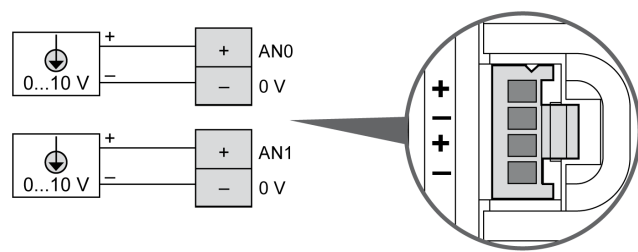

The (-) poles are connected internally.

Pin	Wire Color
AN0	Red
0 V	Black
AN1	Red
0 V	Black

For more information, refer to the *Wiring Best Practices*, page 74.

TM221ME16R / TM221ME16RG

What's in This Chapter

TM221ME16R / TM221ME16RG Presentation	190
TM221ME16R / TM221ME16RG Digital Inputs	193
TM221ME16R / TM221ME16RG Digital Outputs	196
TM221ME16R / TM221ME16RG Analog Inputs.....	199

Overview

This chapter describes the TM221ME16R / TM221ME16RG controllers.

TM221ME16R / TM221ME16RG Presentation

Overview

The following features are integrated into the TM221ME16R (screw) and TM221ME16RG (spring) controllers:

- 8 digital inputs
 - 4 regular inputs
 - 4 fast inputs (HSC)
- 8 digital outputs
 - 8 relay outputs
- 2 analog inputs
- Communication port
 - 1 serial line port
 - 1 USB mini-B programming port
 - 1 Ethernet port

Description

The following figure shows the different components of the controllers:

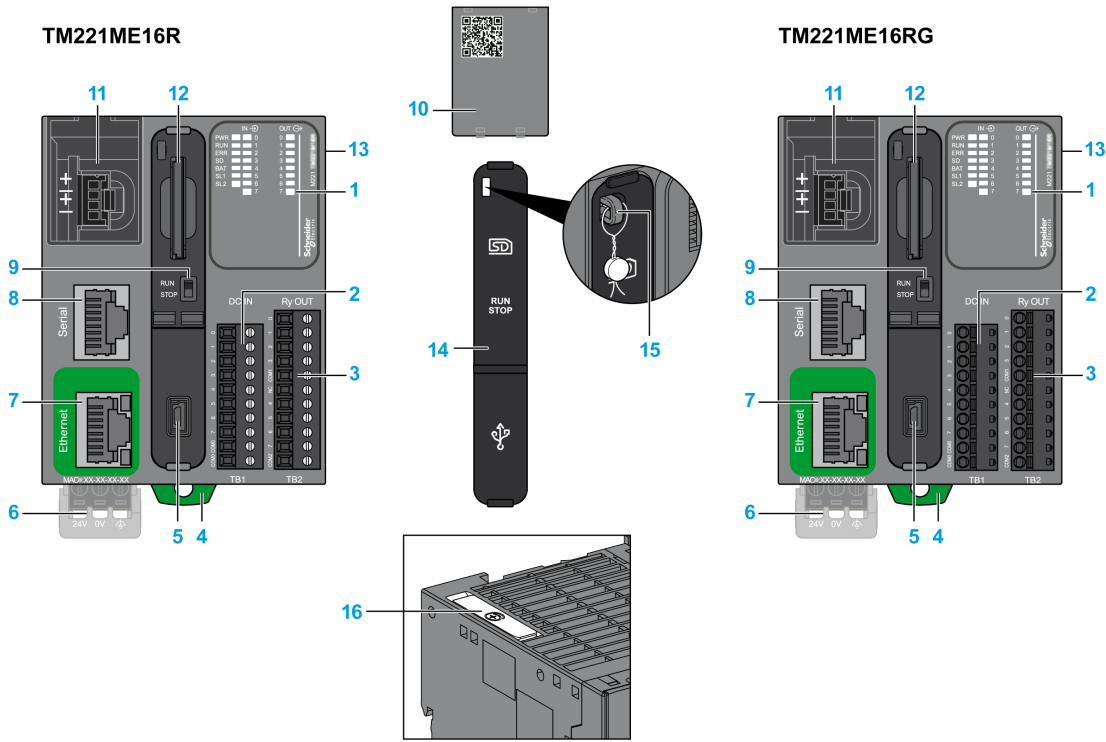

N°	Description	Refer to
1	Status LEDs	—
2	Input removable terminal block	Rules for Removable Screw Terminal Block, page 76
3	Output removable terminal block	Rules for Removable Spring Terminal Block, page 77
4	Clip-on lock for 35 mm (1.38 in.) top hat section rail (DIN-rail)	DIN Rail
5	USB mini-B programming port / For terminal connection to a programming PC (EcoStruxure Machine Expert - Basic)	USB mini-B programming port , page 257
6	24 Vdc power supply	Power supply, page 79
7	Ethernet port / RJ45 connector	Ethernet port, page 258
8	Serial line port 1 / RJ45 connector (RS-232 or RS-485)	Serial line 1, page 260
9	Run/Stop switch	Run/Stop switch , page 53
10	Removable analog inputs cover	—
11	2 analog inputs	Analog Inputs, page 199
12	SD Card slot	SD Card Slot, page 55
13	I/O expansion connector	—
14	Protective cover (SD Card slot, Run/Stop switch and USB mini-B programming port)	—
15	Locking hook	—
16	Battery holder	Installing and Replacing the Battery, page 45

Status LEDs

The following figure shows the status LEDs:

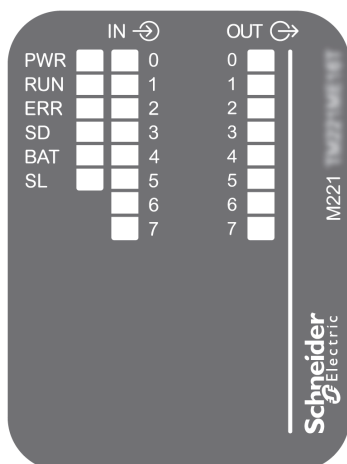

The following table describes the status LEDs:

Label	Function Type	Color	Status	Description		
				Controller States ⁽¹⁾	Prg Port Communication	Application Execution
PWR	Power	Green	On	Indicates that power is applied.		
			Off	Indicates that power is removed.		
RUN	Machine Status	Green	On	Indicates that the controller is running a valid application.		
			Flashing	Indicates that the controller has a valid application that is stopped.		
			Off	Indicates that the controller is not programmed.		
ERR	Error	Red	On*	EXCEPTION	Restricted	NO
			Flashing (with RUN status LED Off)	INTERNAL ERROR	Restricted	NO
			Slow flash	Minor error detected ⁽²⁾	Yes	Depends on the RUN status LED
			1 single flash	No application	Yes	Yes
SD	SD Card Access, page 55	Green	On	Indicates that the SD card is being accessed.		
			Flashing	Indicates that an error was detected during the SD card operation.		
			Off	Indicates no access (idle) or no card is present.		
BAT	Battery, page 44	Red	On	Indicates that the battery needs to be replaced.		
			Flashing	Indicates that the battery charge is low.		
			Off	Indicates that the battery is OK.		
SL	Serial line 1, page 260	Green	On	Indicates the status of Serial line 1.		
			Flashing	Indicates activity on Serial line 1.		
			Off	Indicates no serial communication.		
<p>* ERR LED is also On during booting process.</p> <p>NOTE: For information about the LEDs integrated into the Ethernet connector, refer to Ethernet Status LEDs, page 260</p> <p>(1) For more information about the controller state description, refer to the M221 Logic Controller - Programming Guide (see Modicon M221, Logic Controller, Programming Guide).</p> <p>(2) The controller detected an error but remains in RUNNING state. The ERR LED on the controller flashes. For more information, refer to M221 Logic Controller - Programming Guide.</p>						

Dimensions

The following figure shows the external dimensions of the controllers:

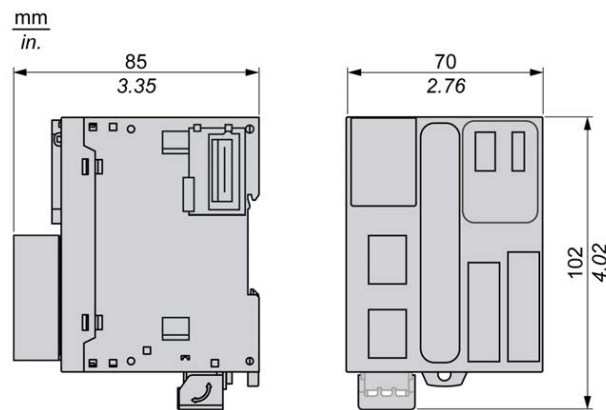

TM221ME16R / TM221ME16RG Digital Inputs

Overview

This M221 Logic Controller has embedded digital inputs:

- 4 regular inputs
- 4 fast inputs which can be used as 100 kHz HSC inputs

For more information, refer to Input Management, page 48.

⚠ DANGER

FIRE HAZARD

- Use only the correct wire sizes for the maximum current capacity of the I/O channels and power supplies.
- For relay output (2 A) wiring, use conductors of at least 0.5 mm² (AWG 20) with a temperature rating of at least 80 °C (176 °F).
- For common conductors of relay output wiring (7 A), or relay output wiring greater than 2 A, use conductors of at least 1.0 mm² (AWG 16) with a temperature rating of at least 80 °C (176 °F).

Failure to follow these instructions will result in death or serious injury.

⚠ WARNING

UNINTENDED EQUIPMENT OPERATION

Do not exceed any of the rated values specified in the environmental and electrical characteristics tables.

Failure to follow these instructions can result in death, serious injury, or equipment damage.

Regular Input Characteristics

The following table describes the characteristics of the TM221M Logic Controller regular inputs:

Characteristic		Value
Number of regular inputs		4 inputs (I2, I3, I4, I5)
Number of channel groups		1 common line for I0...I7
Input type		Type 1 (IEC/EN 61131-2)
Logic type		Sink/Source
Input voltage range		24 Vdc
Rated input voltage		19.2...28.8 Vdc
Rated input current		7 mA
Input impedance		3.4 k Ω
Input limit values	Voltage at state 1	> 15 Vdc (15...28.8 Vdc)
	Voltage at state 0	< 5 Vdc (0...5 Vdc)
	Current at state 1	> 2.5 mA
	Current at state 0	< 1.0 mA
Derating		No derating
Turn on time		35 μ s + filter value ⁽¹⁾
Turn off time		35 μ s + filter value ⁽¹⁾
Isolation	Between input and internal logic	500 Vac
Connection type	TM221ME16R	Removable screw terminal blocks
	TM221ME16RG	Removable spring terminal blocks
Connector insertion/removal durability		Over 100 times
Cable	Type	Unshielded
	Length	Maximum 30 m (98 ft)
(1) For more information, refer to Integrator Filter Principle, page 48		

Fast Input Characteristics

The following table describes the characteristics of the TM221M Logic Controller fast inputs:

Characteristic		Value
Number of fast inputs		4 inputs (I0, I1, I6, I7)
Number of channel groups		1 common line for I0...I7
Input type		Type 1 (IEC/EN 61131-2)
Logic type		Sink/Source
Rated input voltage		24 Vdc
Input voltage range		19.2...28.8 Vdc
Rated input current		4.5 mA
Input impedance		4.9 k Ω

Characteristic		Value
Input limit values	Voltage at state 1	> 15 Vdc (15...28.8 Vdc)
	Voltage at state 0	< 5 Vdc (0...5 Vdc)
	Current at state 1	> 2.5 mA
	Current at state 0	< 1.0 mA
Derating		No derating
Turn on time		5 μs + filter value ⁽¹⁾
Turn off time		5 μs + filter value ⁽¹⁾
HSC maximum frequency	Dual Phase	100 kHz
	Single phase	100 kHz
	Frequency Meter	100 kHz
HSC supported operation mode		<ul style="list-style-type: none"> • Dual Phase [Pulse / Direction] • Dual Phase [Quadrature X1] • Dual Phase [Quadrature X2] • Dual Phase [Quadrature X4] • Single Phase • Frequency Meter
Isolation	Between input and internal logic	500 Vac
	Between channel groups	500 Vac
Connection type	TM221ME16R	Removable screw terminal block
	TM221ME16RG	Removable spring terminal block
Connector insertion/removal durability		Over 100 times
Cable	Type	Shielded, including the 24 Vdc power supply
	Length	Maximum 10 m (32.8 ft)
(1) For more information, refer to Integrator Filter Principle, page 48		

Wiring Diagram

The following figure presents the connection of the inputs to the sensors:

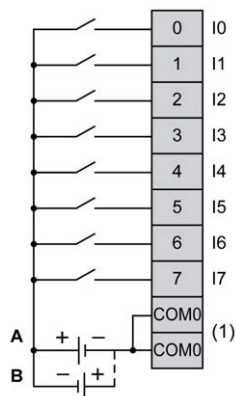

(1) The COM0 terminals are connected internally.

A Sink wiring (positive logic).

B Source wiring (negative logic).

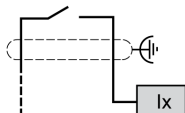

Ix I0, I1, I6, I7

TM221ME16R / TM221ME16RG Digital Outputs

Overview

M221 Logic Controller with 8 relay outputs embedded.

For more information on Output Management, page 50.

⚠ DANGER

FIRE HAZARD

- Use only the correct wire sizes for the maximum current capacity of the I/O channels and power supplies.
- For relay output (2 A) wiring, use conductors of at least 0.5 mm² (AWG 20) with a temperature rating of at least 80 °C (176 °F).
- For common conductors of relay output wiring (7 A), or relay output wiring greater than 2 A, use conductors of at least 1.0 mm² (AWG 16) with a temperature rating of at least 80 °C (176 °F).

Failure to follow these instructions will result in death or serious injury.

⚠ WARNING

UNINTENDED EQUIPMENT OPERATION

Do not exceed any of the rated values specified in the environmental and electrical characteristics tables.

Failure to follow these instructions can result in death, serious injury, or equipment damage.

Relay Output Characteristics

The following table describes the characteristics of the TM221M Logic Controller with relay outputs:

Characteristic	Value
Number of relay outputs	8 outputs
Number of channel groups	1 common line for Q0...Q3 1 common line for Q4...Q7
Output type	Relay
Contact type	NO (Normally Open)
Rated output voltage	24 Vdc, 240 Vac
Maximum voltage at 2 A	30 Vdc, 264 Vac
Minimum switching load	5 Vdc at 1 mA
Rated output current	2 A
Maximum output current	2 A per output

Characteristic		Value
		7 A per common
Maximum output frequency with maximum load		20 operations per minute
Derating		No derating
Turn on time		Max. 10 ms
Turn off time		Max. 10 ms
Contact resistance		30 mΩ max
Mechanical life		20 million operations
Electrical life	Under resistive load	See power limitation, page 197
	Under inductive load	
Protection against short circuit		No
Isolation	Between output and internal logic	500 Vac
	Between channel groups	500 Vac
Connection type	TM221ME16R	Removable screw terminal blocks
	TM221ME16RG	Removable spring terminal blocks
Connector insertion/removal durability		Over 100 times
Cable	Type	Unshielded
	Length	Max. 30 m (98 ft)
<p>NOTE: Refer to Protecting Outputs from Inductive Load Damage, page 78 for additional information concerning output protection.</p>		

Power Limitation

The following table describes the power limitation of the TM221ME16R / TM221ME16RG relay outputs controllers depending on the voltage, the type of load, and the number of operations required.

These controllers do not support capacitive loads.

⚠ WARNING
<p>RELAY OUTPUTS WELDED CLOSED</p> <ul style="list-style-type: none"> Always protect relay outputs from inductive alternating current load damage using an appropriate external protective circuit or device. Do not connect relay outputs to capacitive loads. <p>Failure to follow these instructions can result in death, serious injury, or equipment damage.</p>

Power Limitations				
Voltage	24 Vdc	120 Vac	240 Vac	Number of operations
Power of resistive loads AC-12	–	240 VA	480 VA	100,000
		80 VA	160 VA	300,000
Power of inductive loads AC-15 (cos φ = 0.35)	–	60 VA	120 VA	100,000
		18 VA	36 VA	300,000
Power of inductive loads AC-14 (cos φ = 0.7)	–	120 VA	240 VA	100,000
		36 VA	72 VA	300,000

Power Limitations				
Power of resistive loads	48 W	–	–	100,000
DC-12	16 W			300,000
Power of inductive loads	24 W	–	–	100,000
DC-13 L/R = 7 ms	7.2 W			300,000

Wiring Diagram

The following figure presents the connection of the outputs to the load:

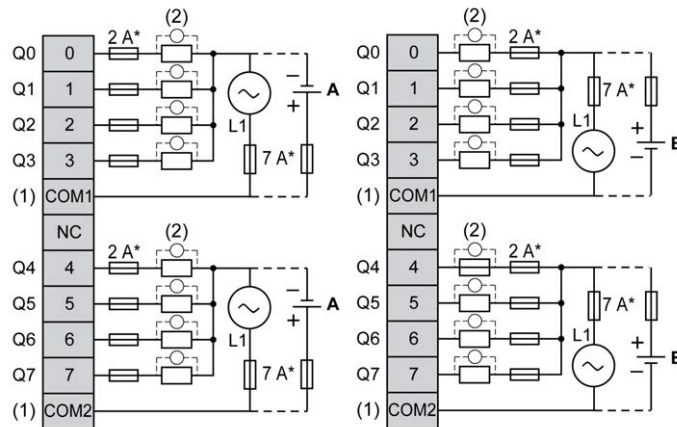

* Type T fuse

(1) The COM1 and COM2 terminals are **not** connected internally.

(2) To improve the life time of the contacts, and to protect from potential inductive load damage, you must connect a free wheeling diode in parallel to each inductive DC load or an RC snubber in parallel of each inductive AC load

A Source wiring (positive logic).

B Sink wiring (negative logic).

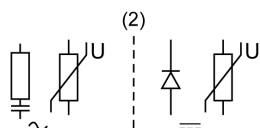

NOTE: The assigned fuse values have been specified for the maximum current characteristics of the controller I/O and associated commons. You may have other considerations that are applicable based on the unique types of input and output devices you connect, or conformance to local, national or applicable certification regulations and standards, and you should size your fuses accordingly.

⚠ WARNING

UNINTENDED EQUIPMENT OPERATION

Do not connect wires to unused terminals and/or terminals indicated as “No Connection (N.C.)”.

Failure to follow these instructions can result in death, serious injury, or equipment damage.

TM221ME16R / TM221ME16RG Analog Inputs

Overview

The M221 Logic Controllers have 2 analog inputs embedded.

DANGER

FIRE HAZARD

- Use only the correct wire sizes for the maximum current capacity of the I/O channels and power supplies.
- For relay output (2 A) wiring, use conductors of at least 0.5 mm² (AWG 20) with a temperature rating of at least 80 °C (176 °F).
- For common conductors of relay output wiring (7 A), or relay output wiring greater than 2 A, use conductors of at least 1.0 mm² (AWG 16) with a temperature rating of at least 80 °C (176 °F).

Failure to follow these instructions will result in death or serious injury.

WARNING

UNINTENDED EQUIPMENT OPERATION

Do not exceed any of the rated values specified in the environmental and electrical characteristics tables.

Failure to follow these instructions can result in death, serious injury, or equipment damage.

The following procedure describes how to mount the analog cables:

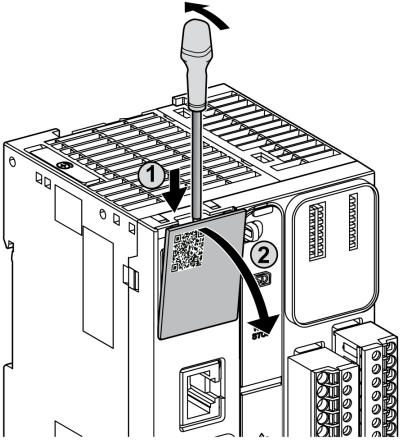
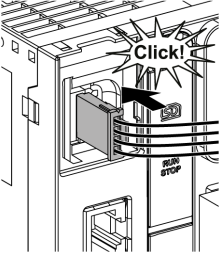
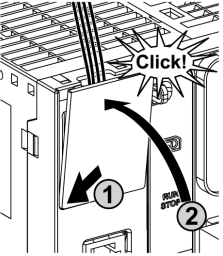
Step	Action
1	Use a screw-driver to remove the protective cover. 
2	Push until you hear it "click". 
3	Replace the protective cover. 

Analog Input Characteristics

The following table describes the characteristics of the M221 Logic Controller with analog inputs:

Characteristic	Voltage Input
Number of maximum inputs	2 inputs
Input type	Single-ended
Rated input range	0...+10 Vdc
Digital resolution	10 bits
Input value of LSB	10 mV
Input impedance	100 kΩ
Input delay time	12 ms
Sample duration time	1 ms per channel + 1 scan time
Accuracy	± 1 % of the full scale

Characteristic		Voltage Input
Noise resistance - maximum temporary deviation during perturbations		± 5 % maximum of the full scale when EMC perturbation is applied to the power and I/O wiring
Isolation	Between input and internal logic	Not isolated
Connection type		Specific connector and cable (supplied)
Connector insertion/removal durability		Over 100 times
Cable	Type	Proprietary (supplied)
	Length	1 m (3.3 ft)

Wiring Diagram

The following figure shows the wiring diagram of the Modicon M221 Logic Controller analog inputs:

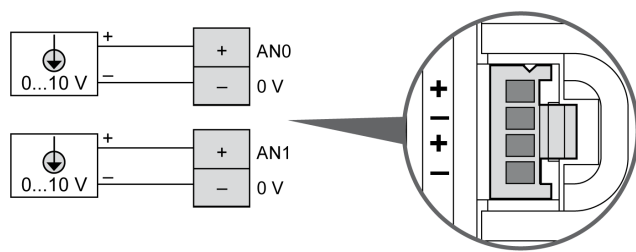

The (-) poles are connected internally.

Pin	Wire Color
AN0	Red
0 V	Black
AN1	Red
0 V	Black

For more information, refer to the *Wiring Best Practices*, page 74.

TM221M16T / TM221M16TG

What's in This Chapter

TM221M16T / TM221M16TG Presentation	202
TM221M16T / TM221M16TG Digital Inputs	205
TM221M16T / TM221M16TG Digital Outputs	209
TM221M16T / TM221M16TG Analog Inputs	213

Overview

This chapter describes the TM221M16T / TM221M16TG controllers.

TM221M16T / TM221M16TG Presentation

Overview

The following features are integrated into the TM221M16T (screw) and TM221M16TG (spring) controllers:

- 8 digital inputs
 - 4 regular inputs
 - 4 fast inputs (HSC)
- 8 digital outputs
 - 6 regular transistor outputs
 - 2 fast transistor outputs
- 2 analog inputs
- Communication port
 - 2 serial line ports
 - 1 USB mini-B programming port

Description

The following figure shows the different components of the controllers:

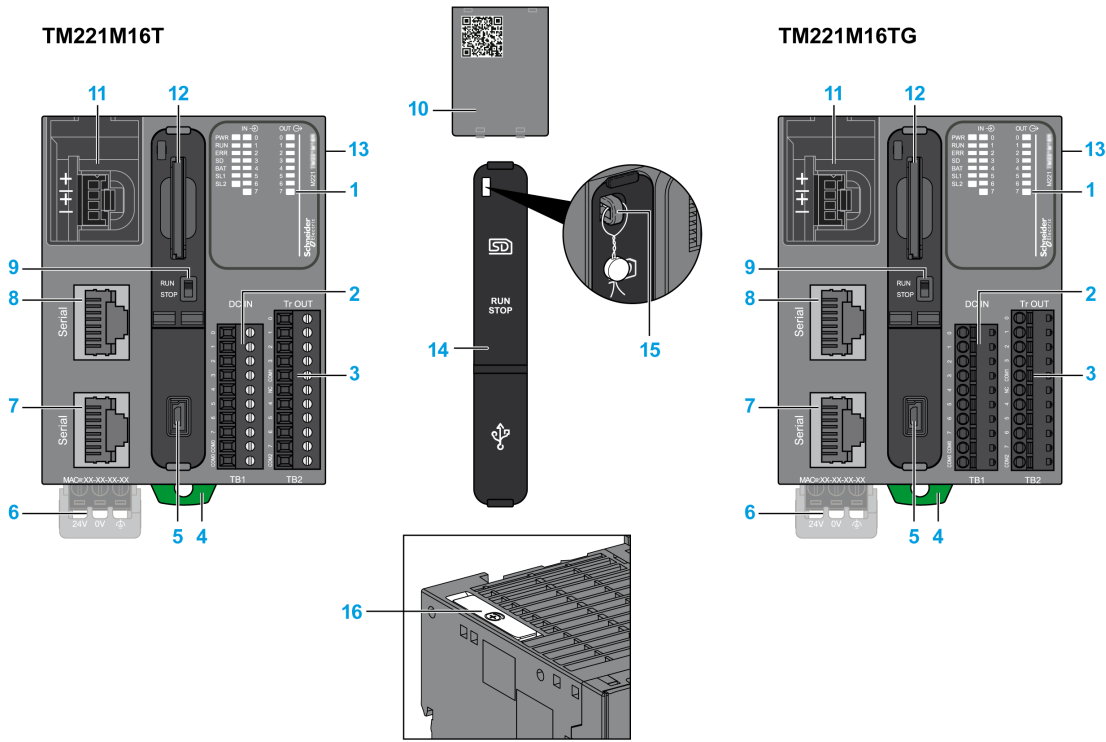

N°	Description	Refer to
1	Status LEDs	–
2	Input removable terminal block	Rules for Removable Screw Terminal Block, page 76
3	Output removable terminal block	Rules for Removable Spring Terminal Block, page 77
4	Clip-on lock for 35 mm (1.38 in.) top hat section rail (DIN-rail)	DIN Rail
5	USB mini-B programming port / For terminal connection to a programming PC (EcoStruxure Machine Expert - Basic)	USB mini-B programming port , page 257
6	24 Vdc power supply	Power supply, page 79
7	Serial line port 2 / RJ45 connector (RS-485)	Serial line 2, page 263
8	Serial line port 1 / RJ45 connector (RS-232 or RS-485)	Serial line 1, page 260
9	Run/Stop switch	Run/Stop switch , page 53
10	Removable analog inputs cover	–
11	2 analog inputs	Analog Inputs, page 213
12	SD Card slot	SD Card Slot, page 55
13	I/O expansion connector	–
14	Protective cover (SD Card slot, Run/Stop switch and USB mini-B programming port)	–
15	Locking hook	–
16	Battery holder	Installing and Replacing the Battery, page 45

Status LEDs

The following figure shows the status LEDs:

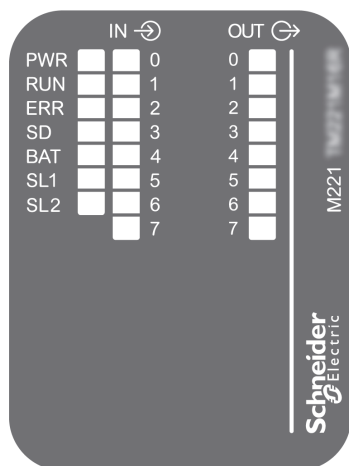

The following table describes the status LEDs:

Label	Function Type	Color	Status	Description		
				Controller States ⁽¹⁾	Prg Port Communication	Application Execution
PWR	Power	Green	On	Indicates that power is applied.		
			Off	Indicates that power is removed.		
RUN	Machine Status	Green	On	Indicates that the controller is running a valid application.		
			Flashing	Indicates that the controller has a valid application that is stopped.		
			Off	Indicates that the controller is not programmed.		
ERR	Error	Red	On*	EXCEPTION	Restricted	NO
			Flashing (with RUN status LED Off)	INTERNAL ERROR	Restricted	NO
			Slow flashing	Minor error detected ⁽²⁾	Yes	Depends on the RUN status LED
			1 single flash	No application	Yes	Yes
SD	SD Card Access, page 55	Green	On	Indicates that the SD card is being accessed.		
			Flashing	Indicates that an error was detected during the SD card operation.		
			Off	Indicates no access (idle) or no card is present.		
BAT	Battery, page 44	Red	On	Indicates that the battery needs to be replaced.		
			Flashing	Indicates that the battery charge is low.		
			Off	Indicates that the battery is OK.		
SL1	Serial line 1, page 260	Green	On	Indicates the status of Serial line 1.		
			Flashing	Indicates activity on Serial line 1.		
			Off	Indicates no serial communication.		
SL2	Serial line 2, page 263	Green	On	Indicates the status of Serial line 2.		
			Flashing	Indicates activity on Serial line 2.		
			Off	Indicates no serial communication.		

Label	Function Type	Color	Status	Description		
				Controller States ⁽¹⁾	Prg Port Communication	Application Execution
* ERR LED is also On during booting process.						
(1) For more information about the controller state description, refer to the M221 Logic Controller - Programming Guide (see Modicon M221, Logic Controller, Programming Guide).						
(2) The controller detected an error but remains in RUNNING state. The ERR LED on the controller flashes. For more information, refer to M221 Logic Controller - Programming Guide.						

Dimensions

The following figure shows the external dimensions of the controllers:

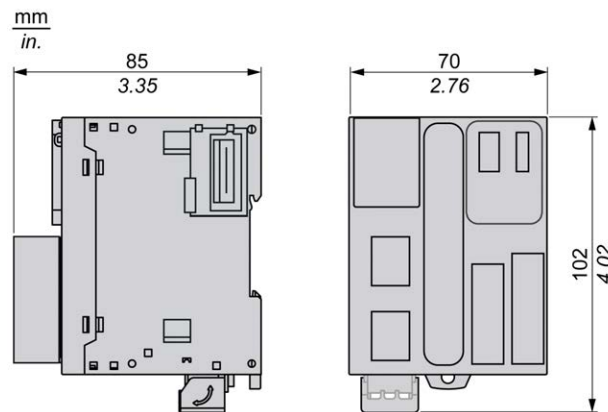

TM221M16T / TM221M16TG Digital Inputs

Overview

This M221 Logic Controller has embedded digital inputs:

- 4 regular inputs
- 4 fast inputs which can be used as 100 kHz HSC inputs

For more information, refer to Input Management, page 48.

⚠ DANGER

FIRE HAZARD

- Use only the correct wire sizes for the maximum current capacity of the I/O channels and power supplies.
- For relay output (2 A) wiring, use conductors of at least 0.5 mm² (AWG 20) with a temperature rating of at least 80 °C (176 °F).
- For common conductors of relay output wiring (7 A), or relay output wiring greater than 2 A, use conductors of at least 1.0 mm² (AWG 16) with a temperature rating of at least 80 °C (176 °F).

Failure to follow these instructions will result in death or serious injury.

⚠ WARNING**UNINTENDED EQUIPMENT OPERATION**

Do not exceed any of the rated values specified in the environmental and electrical characteristics tables.

Failure to follow these instructions can result in death, serious injury, or equipment damage.

Regular Input Characteristics

The following table describes the characteristics of the TM221M Logic Controller regular inputs:

Characteristic		Value
Number of regular inputs		4 inputs (I2, I3, I4, I5)
Number of channel groups		1 common line for I0...I7
Input type		Type 1 (IEC/EN 61131-2)
Logic type		Sink/Source
Input voltage range		24 Vdc
Rated input voltage		19.2...28.8 Vdc
Rated input current		7 mA
Input impedance		3.4 kΩ
Input limit values	Voltage at state 1	> 15 Vdc (15...28.8 Vdc)
	Voltage at state 0	< 5 Vdc (0...5 Vdc)
	Current at state 1	> 2.5 mA
	Current at state 0	< 1.0 mA
Derating		see Derating Curve, page 208
Turn on time		35 μs + filter value ⁽¹⁾
Turn off time		35 μs + filter value ⁽¹⁾
Isolation	Between input and internal logic	500 Vac
Connection type	TM221M16T	Removable screw terminal blocks
	TM221M16TG	Removable spring terminal blocks
Connector insertion/removal durability		Over 100 times
Cable	Type	Unshielded
	Length	Maximum 30 m (98 ft)
(1) For more information, refer to Integrator Filter Principle, page 48		

Fast Input Characteristics

The following table describes the characteristics of the TM221M Logic Controller fast inputs:

Characteristic		Value
Number of fast inputs		4 inputs (I0, I1, I6, I7)
Number of channel groups		1 common line for I0...I7
Input type		Type 1 (IEC/EN 61131-2)
Logic type		Sink/Source
Rated input voltage		24 Vdc
Input voltage range		19.2...28.8 Vdc
Rated input current		4.5 mA
Input impedance		4.9 kΩ
Input limit values	Voltage at state 1	> 15 Vdc (15...28.8 Vdc)
	Voltage at state 0	< 5 Vdc (0...5 Vdc)
	Current at state 1	2.6 mA
	Current at state 0	< 1.0 mA
Derating		see Derating Curve, page 208
Turn on time		5 μs + filter value ⁽¹⁾
Turn off time		5 μs + filter value ⁽¹⁾
HSC maximum frequency	Dual Phase	100 kHz
	Single phase	100 kHz
	Frequency Meter	100 kHz
HSC supported operation mode		<ul style="list-style-type: none"> • Dual Phase [Pulse / Direction] • Dual Phase [Quadrature X1] • Dual Phase [Quadrature X2] • Dual Phase [Quadrature X4] • Single Phase • Frequency Meter
Isolation	Between input and internal logic	500 Vac
	Between channel groups	500 Vac
Connection type	TM221M16T	Removable screw terminal block
	TM221M16TG	Removable spring terminal block
Connector insertion/removal durability		Over 100 times
Cable	Type	Shielded, including the 24 Vdc power supply
	Length	Maximum 10 m (32.8 ft)
(1) For more information, refer to Integrator Filter Principle, page 48		

Derating Curves

The following figures show the derating curves of the embedded digital inputs:

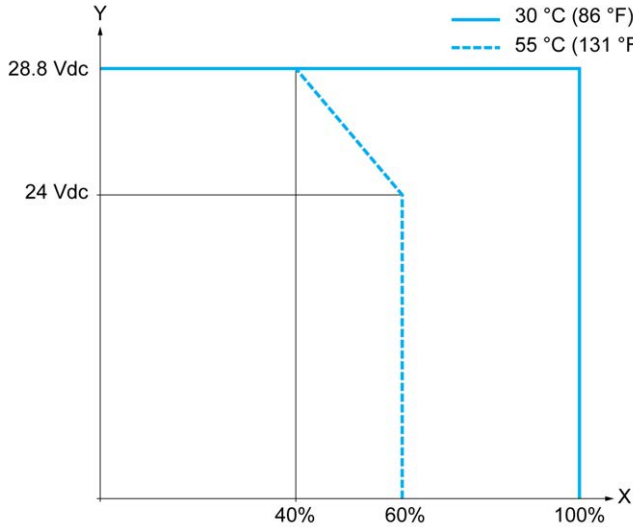

X Input simultaneous ON ratio

Y Input voltage

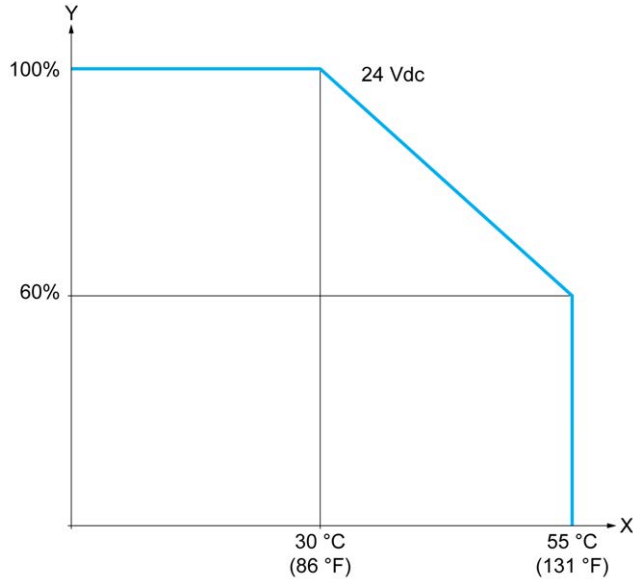

X Ambient temperature

Y Input simultaneous ON ratio

Wiring Diagram

The following figure presents the connection of the inputs to the sensors:

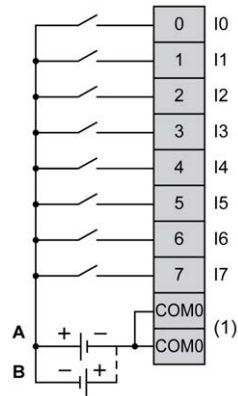

(1) The COM0 terminals are connected internally.

A Sink wiring (positive logic).

B Source wiring (negative logic).

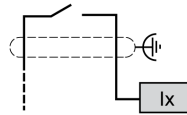

Ix I0, I1, I6, I7

TM221M16T / TM221M16TG Digital Outputs

Overview

The TM221M16T and TM221M16TG have digital outputs embedded:

- 6 regular transistor outputs
- 2 fast transistor outputs

For more information, refer to [Output Management](#), page 50.

⚠ DANGER

FIRE HAZARD

- Use only the correct wire sizes for the maximum current capacity of the I/O channels and power supplies.
- For relay output (2 A) wiring, use conductors of at least 0.5 mm² (AWG 20) with a temperature rating of at least 80 °C (176 °F).
- For common conductors of relay output wiring (7 A), or relay output wiring greater than 2 A, use conductors of at least 1.0 mm² (AWG 16) with a temperature rating of at least 80 °C (176 °F).

Failure to follow these instructions will result in death or serious injury.

⚠ WARNING**UNINTENDED EQUIPMENT OPERATION**

Do not exceed any of the rated values specified in the environmental and electrical characteristics tables.

Failure to follow these instructions can result in death, serious injury, or equipment damage.

Regular Transistor Output Characteristics

The following table describes the characteristics of the TM221M Logic Controller regular transistor outputs:

Characteristic		Value
Number of regular transistor outputs		6 regular outputs (Q2...Q7)
Number of channel groups		1 common line for Q0...Q7
Output type		Transistor
Logic type		Source
Rated output voltage		24 Vdc
Output voltage range		19.2...28.8 Vdc
Rated output current		0.5 A
Total output current		4 A
Voltage drop		1 Vdc max
Leakage current when switched off		0.1 mA
Maximum power of filament lamp		12 W max
Derating		see Derating Curve, page 212
Turn on time	Q2...Q3	Max. 50 μ s
	Q4...Q7	Max. 300 μ s
Turn off time	Q2...Q3	Max. 50 μ s
	Q4...Q7	Max. 300 μ s
Protection against short circuit		Yes
Short circuit output peak current		1.3 A
Automatic rearming after short circuit or overload		Yes, every 1 s
Clamping voltage		Max. 39 Vdc \pm 1 Vdc
Switching frequency	Under resistive load	100 Hz max.
Isolation	Between output and internal logic	500 Vac
Connection type	TM221M16T	Removable screw terminal blocks
	TM221M16TG	Removable spring terminal blocks
Connector insertion/removal durability		Over 100 times
Cable	Type	Unshielded
	Length	Max 30 m (98 ft)
<p>NOTE: Refer to Protecting Outputs from Inductive Load Damage, page 78 for additional information concerning output protection.</p>		

Fast Transistor Output Characteristics

The following table describes the characteristics of the TM221M Logic Controller fast transistor outputs:

Characteristic		Value
Number of fast transistor outputs		2 outputs (Q0, Q1)
Number of channel groups		1 common line for Q0...Q7
Output type		Transistor
Logic type		Source
Rated output voltage		24 Vdc
Output voltage range		19.2...28.8 Vdc
Rated output current		0.5 A
Total output current		4 A
Maximum power of filament lamp		12 W max
Derating		see Derating Curve, page 212
Turn on time (10 mA < output current < 100 mA)		Max. 5 μ s
Turn off time (10 mA < output current < 100 mA)		Max. 5 μ s
Protection against short circuit		Yes
Short circuit output peak current		1.3 A max.
Automatic rearming after short circuit or overload		Yes, every 1 s
Protection against reverse polarity		Yes
Clamping voltage		Typ. 39 Vdc +/- 1 Vdc
Maximum output frequency	PLS/PWM/PTO/FREQGEN	100 kHz
Isolation	Between output and internal logic	500 Vac
Connection type	TM221M16T	Removable screw terminal blocks
	TM221M16TG	Removable spring terminal blocks
Connector insertion/removal durability		Over 100 times
Cable	Type	Shielded, including 24 Vdc power supply
	Length	Maximum 3 m (9.84 ft)
<p>NOTE: Refer to Protecting Outputs from Inductive Load Damage, page 78 for additional information concerning output protection.</p>		

Derating Curves

The following figures show the derating curves of the embedded digital outputs:

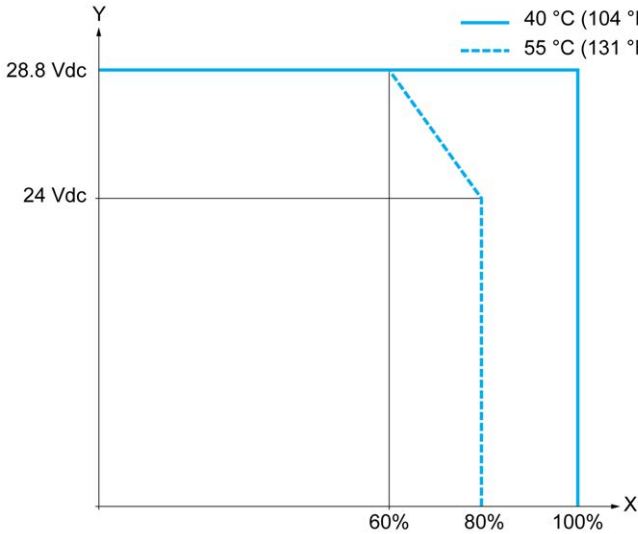

X Output simultaneous ON ratio

Y Output voltage

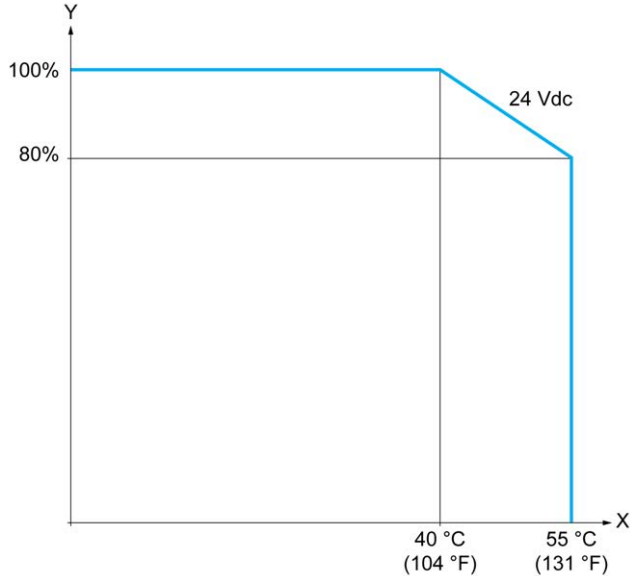

X Ambient temperature

Y Output simultaneous ON ratio

Wiring Diagram

The following figure presents the connection of the outputs to the load:

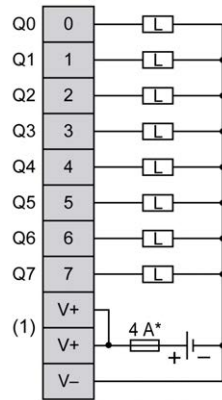

* Type T fuse

(1) The V+ terminals are connected internally.

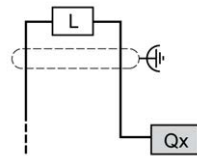

Qx Q0, Q1

TM221M16T / TM221M16TG Analog Inputs

Overview

The M221 Logic Controllers have 2 analog inputs embedded.

⚠ DANGER

FIRE HAZARD

- Use only the correct wire sizes for the maximum current capacity of the I/O channels and power supplies.
- For relay output (2 A) wiring, use conductors of at least 0.5 mm² (AWG 20) with a temperature rating of at least 80 °C (176 °F).
- For common conductors of relay output wiring (7 A), or relay output wiring greater than 2 A, use conductors of at least 1.0 mm² (AWG 16) with a temperature rating of at least 80 °C (176 °F).

Failure to follow these instructions will result in death or serious injury.

⚠ WARNING

UNINTENDED EQUIPMENT OPERATION

Do not exceed any of the rated values specified in the environmental and electrical characteristics tables.

Failure to follow these instructions can result in death, serious injury, or equipment damage.

The following procedure describes how to mount the analog cables:

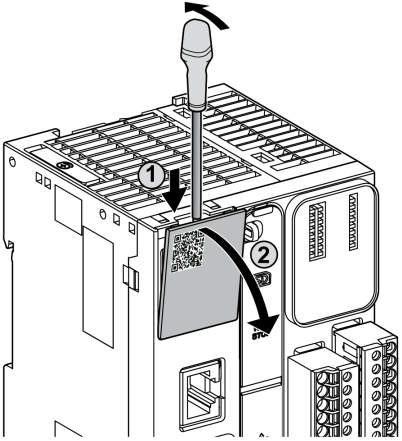
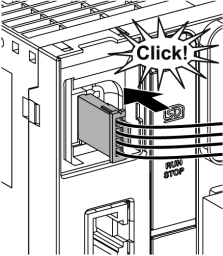
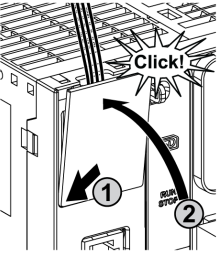
Step	Action
1	Use a screw-driver to remove the protective cover. 
2	Push until you hear it "click". 
3	Replace the protective cover. 

Analog Input Characteristics

The following table describes the characteristics of the M221 Logic Controller with analog inputs:

Characteristic	Voltage Input
Number of maximum inputs	2 inputs
Input type	Single-ended
Rated input range	0...+10 Vdc
Digital resolution	10 bits
Input value of LSB	10 mV
Input impedance	100 k Ω
Input delay time	12 ms
Sample duration time	1 ms per channel + 1 scan time
Accuracy	$\pm 1\%$ of the full scale

Characteristic		Voltage Input
Noise resistance - maximum temporary deviation during perturbations		± 5 % maximum of the full scale when EMC perturbation is applied to the power and I/O wiring
Isolation	Between input and internal logic	Not isolated
Connection type		Specific connector and cable (supplied)
Connector insertion/removal durability		Over 100 times
Cable	Type	Proprietary (supplied)
	Length	1 m (3.3 ft)

Wiring Diagram

The following figure shows the wiring diagram of the Modicon M221 Logic Controller analog inputs:

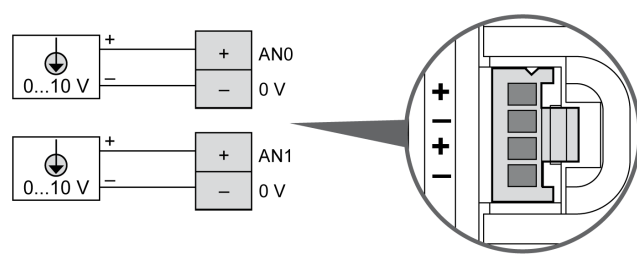

The (-) poles are connected internally.

Pin	Wire Color
AN0	Red
0 V	Black
AN1	Red
0 V	Black

For more information, refer to the *Wiring Best Practices*, page 74.

TM221ME16T / TM221ME16TG

What's in This Chapter

TM221ME16T / TM221ME16TG Presentation	216
TM221ME16T / TM221ME16TG Digital Inputs.....	219
TM221ME16T / TM221ME16TG Digital Outputs	223
TM221ME16T / TM221ME16TG Analog Inputs	226

Overview

This chapter describes the TM221ME16T / TM221ME16TG controllers.

TM221ME16T / TM221ME16TG Presentation

Overview

The following features are integrated into the TM221ME16T (screw) and TM221ME16TG (spring) controllers:

- 8 digital inputs
 - 4 regular inputs
 - 4 fast inputs (HSC)
- 8 digital outputs
 - 6 regular transistor outputs
 - 2 fast transistor outputs
- 2 analog inputs
- Communication port
 - 1 serial line port
 - 1 USB mini-B programming port
 - 1 Ethernet port

Description

The following figure shows the different components of the controllers:

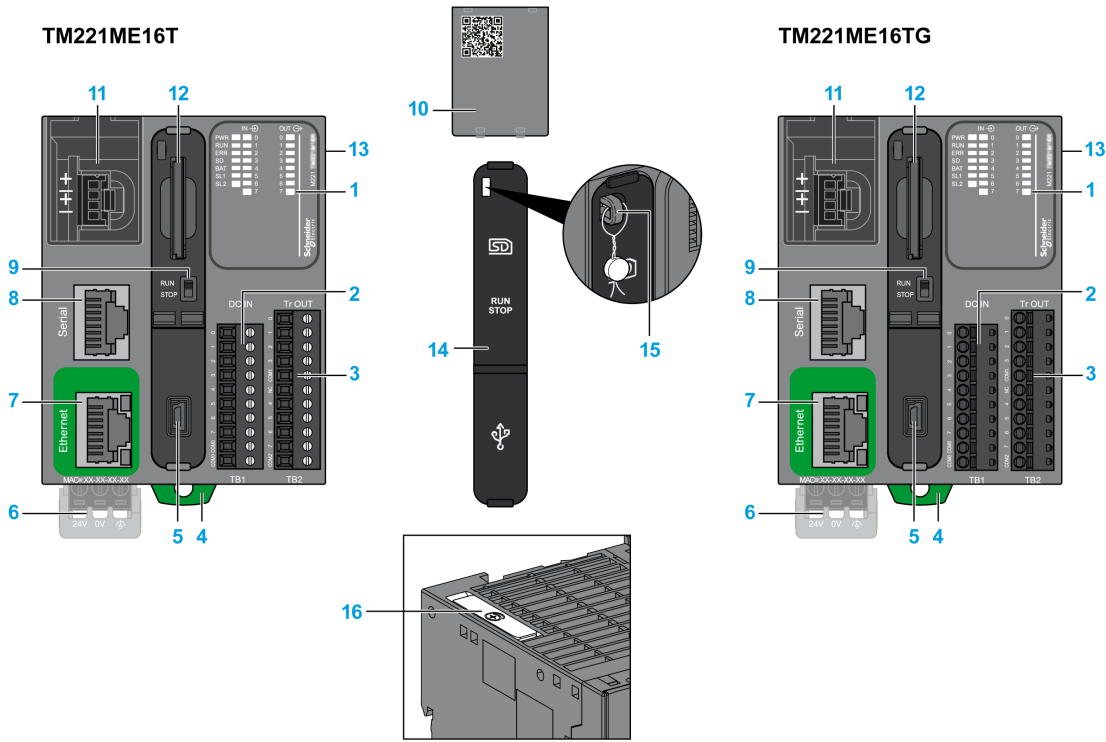

N°	Description	Refer to
1	Status LEDs	–
2	Input removable terminal block	Rules for Removable Screw Terminal Block, page 76
3	Output removable terminal block	Rules for Removable Spring Terminal Block, page 77
4	Clip-on lock for 35 mm (1.38 in.) top hat section rail (DIN-rail)	DIN Rail
5	USB mini-B programming port / For terminal connection to a programming PC (EcoStruxure Machine Expert - Basic)	USB mini-B programming port , page 257
6	24 Vdc power supply	Power supply, page 79
7	Ethernet port / RJ45 connector	Ethernet port, page 258
8	Serial line port 1 / RJ45 connector (RS-232 or RS-485)	Serial line 1, page 260
9	Run/Stop switch	Run/Stop switch , page 53
10	Removable analog inputs cover	–
11	2 analog inputs	Analog Inputs, page 226
12	SD Card slot	SD Card Slot, page 55
13	I/O expansion connector	–
14	Protective cover (SD Card slot, Run/Stop switch and USB mini-B programming port)	–
15	Locking hook	–
16	Battery holder	Installing and Replacing the Battery, page 45

Status LEDs

The following figure shows the status LEDs:

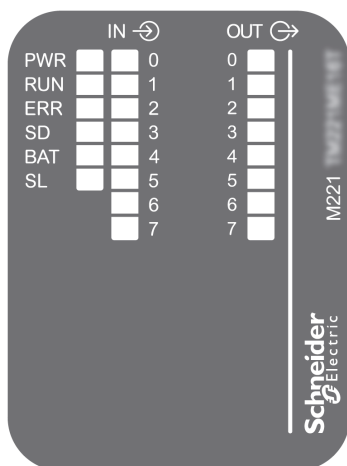

The following table describes the status LEDs:

Label	Function Type	Color	Status	Description		
				Controller States ⁽¹⁾	Prg Port Communication	Application Execution
PWR	Power	Green	On	Indicates that power is applied.		
			Off	Indicates that power is removed.		
RUN	Machine Status	Green	On	Indicates that the controller is running a valid application.		
			Flashing	Indicates that the controller has a valid application that is stopped.		
			Off	Indicates that the controller is not programmed.		
ERR	Error	Red	On*	EXCEPTION	Restricted	NO
			Flashing (with RUN status LED Off)	INTERNAL ERROR	Restricted	NO
			Slow flash	Minor error detected ⁽²⁾	Yes	Depends on the RUN status LED
			1 single flash	No application	Yes	Yes
SD	SD Card Access, page 55	Green	On	Indicates that the SD card is being accessed.		
			Flashing	Indicates that an error was detected during the SD card operation.		
			Off	Indicates no access (idle) or no card is present.		
BAT	Battery, page 44	Red	On	Indicates that the battery needs to be replaced.		
			Flashing	Indicates that the battery charge is low.		
			Off	Indicates that the battery is OK.		
SL	Serial line 1, page 260	Green	On	Indicates the status of Serial line 1.		
			Flashing	Indicates activity on Serial line 1.		
			Off	Indicates no serial communication.		

* ERR LED is also On during booting process.

NOTE: For information about the LEDs integrated into the Ethernet connector, refer to Ethernet Status LEDs, page 260

(1) For more information about the controller state description, refer to the M221 Logic Controller - Programming Guide (see Modicon M221, Logic Controller, Programming Guide).

(2) The controller detected an error but remains in RUNNING state. The ERR LED on the controller flashes. For more information, refer to M221 Logic Controller - Programming Guide.

Dimensions

The following figure shows the external dimensions of the controllers:

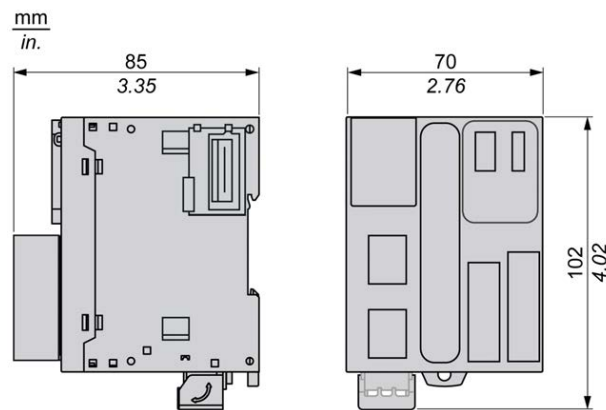

TM221ME16T / TM221ME16TG Digital Inputs

Overview

This M221 Logic Controller has embedded digital inputs:

- 4 regular inputs
- 4 fast inputs which can be used as 100 kHz HSC inputs

For more information, refer to Input Management, page 48.

⚠ DANGER

FIRE HAZARD

- Use only the correct wire sizes for the maximum current capacity of the I/O channels and power supplies.
- For relay output (2 A) wiring, use conductors of at least 0.5 mm² (AWG 20) with a temperature rating of at least 80 °C (176 °F).
- For common conductors of relay output wiring (7 A), or relay output wiring greater than 2 A, use conductors of at least 1.0 mm² (AWG 16) with a temperature rating of at least 80 °C (176 °F).

Failure to follow these instructions will result in death or serious injury.

⚠ WARNING

UNINTENDED EQUIPMENT OPERATION

Do not exceed any of the rated values specified in the environmental and electrical characteristics tables.

Failure to follow these instructions can result in death, serious injury, or equipment damage.

Regular Input Characteristics

The following table describes the characteristics of the TM221M Logic Controller with transistor regular inputs:

Characteristic		Value
Number of regular inputs		4 inputs (I2, I3, I4, I5)
Number of channel groups		1 common line for I0...I7
Input type		Type 1 (IEC/EN 61131-2)
Logic type		Sink/Source
Rated input voltage		24 Vdc
Input voltage range		19.2...28.8 Vdc
Rated input current		7 mA
Input impedance		3.4 k Ω
Input limit values	Voltage at state 1	> 15 Vdc (15...28.8 Vdc)
	Voltage at state 0	< 5 Vdc (0...5 Vdc)
	Current at state 1	> 2.5 mA
	Current at state 0	< 1.0 mA
Derating		see Derating Curve, page 221
Turn on time		35 μ s + filter value ⁽¹⁾
Turn off time		35 μ s + filter value ⁽¹⁾
Isolation	Between input and internal logic	500 Vac
Connection type	TM221ME16T	Removable screw terminal blocks
	TM221ME16TG	Removable spring terminal blocks
Connector insertion/removal durability		Over 100 times
Cable	Type	Unshielded
	Length	Maximum 30 m (98 ft)
(1) For more information, refer to Integrator Filter Principle, page 48		

Fast Input Characteristics

The following table describes the characteristics of the TM221M Logic Controller fast inputs:

Characteristic		Value
Number of fast inputs		4 inputs (I0, I1, I6, I7)
Number of channel groups		1 common line for I0...I7
Input type		Type 1 (IEC/EN 61131-2)
Logic type		Sink/Source
Rated input voltage		24 Vdc
Input voltage range		19.2...28.8 Vdc
Rated input current		4.5 mA
Input impedance		4.9 k Ω

Characteristic		Value
Input limit values	Voltage at state 1	> 15 Vdc (15...28.8 Vdc)
	Voltage at state 0	< 5 Vdc (0...5 Vdc)
	Current at state 1	> 2.5 mA
	Current at state 0	< 1.0 mA
Derating		see Derating Curve, page 221
Turn on time		5 μs + filter value ⁽¹⁾
Turn off time		5 μs + filter value ⁽¹⁾
HSC maximum frequency	Dual Phase	100 kHz
	Single phase	100 kHz
	Frequency Meter	100 kHz
HSC supported operation mode		<ul style="list-style-type: none"> • Dual Phase [Pulse / Direction] • Dual Phase [Quadrature X1] • Dual Phase [Quadrature X2] • Dual Phase [Quadrature X4] • Single Phase • Frequency Meter
Isolation	Between input and internal logic	500 Vac
	Between channel groups	500 Vac
Connection type	TM221ME16T	Removable screw terminal block
	TM221ME16TG	Removable spring terminal block
Connector insertion/removal durability		Over 100 times
Cable	Type	Shielded, including the 24 Vdc power supply
	Length	Maximum 10 m (32.8 ft)
(1) For more information, refer to Integrator Filter Principle, page 48		

Derating Curves

The following figures show the derating curves of the embedded digital inputs:

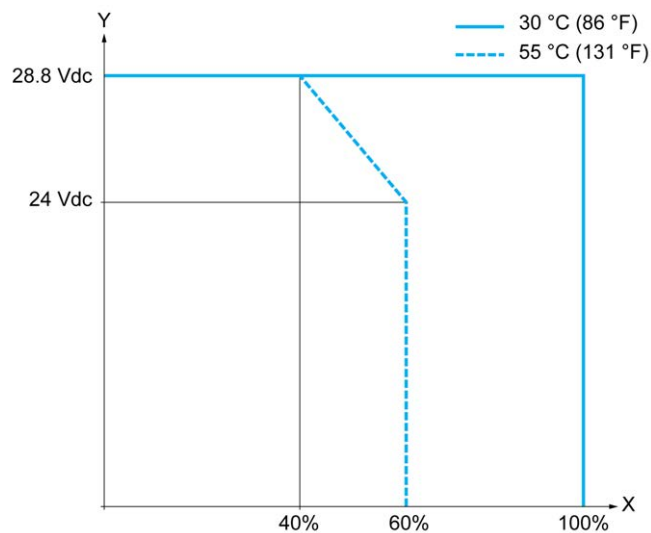

X Input simultaneous ON ratio

Y Input voltage

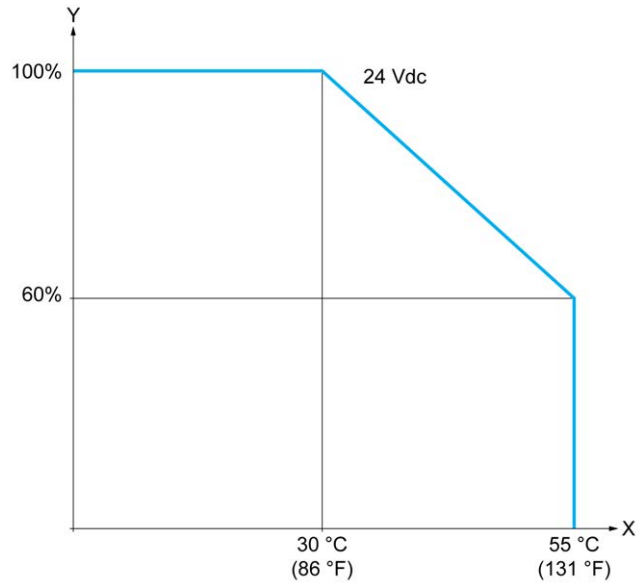

X Ambient temperature

Y Input simultaneous ON ratio

Wiring Diagram

The following figure presents the connection of the inputs to the sensors:

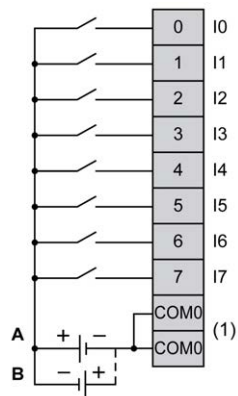

(1) The COM0 terminals are connected internally.

A Sink wiring (positive logic).

B Source wiring (negative logic).

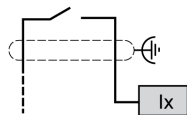

I_x I0, I1, I6, I7

TM221ME16T / TM221ME16TG Digital Outputs

Overview

The TM221ME16T and TM221ME16TG have 8 digital outputs embedded:

- 6 regular transistor outputs
- 2 fast transistor outputs

For more information, refer to [Output Management](#), page 50.

⚠ DANGER
<p>FIRE HAZARD</p> <ul style="list-style-type: none"> • Use only the correct wire sizes for the maximum current capacity of the I/O channels and power supplies. • For relay output (2 A) wiring, use conductors of at least 0.5 mm² (AWG 20) with a temperature rating of at least 80 °C (176 °F). • For common conductors of relay output wiring (7 A), or relay output wiring greater than 2 A, use conductors of at least 1.0 mm² (AWG 16) with a temperature rating of at least 80 °C (176 °F). <p>Failure to follow these instructions will result in death or serious injury.</p>

⚠ WARNING
<p>UNINTENDED EQUIPMENT OPERATION</p> <p>Do not exceed any of the rated values specified in the environmental and electrical characteristics tables.</p> <p>Failure to follow these instructions can result in death, serious injury, or equipment damage.</p>

Regular Transistor Output Characteristics

The following table describes the characteristics of the TM221M Logic Controller regular transistor outputs:

Characteristic	Value	
Number of regular transistor outputs	6 regular outputs (Q2...Q7)	
Number of channel groups	1 common line for Q0...Q7	
Output type	Transistor	
Logic type	Source	
Rated output voltage	24 Vdc	
Output voltage range	19.2...28.8 Vdc	
Rated output current	0.5 A	
Total output current	3 A	
Voltage drop	1 Vdc max	
Leakage current when switched off	0.1 mA	
Maximum power of filament lamp	12 W max	
Derating	see Derating Curve, page 225	
Turn on time	Q2...Q3	Max. 50 µs
	Q4...Q7	Max. 300 µs

Characteristic		Value
Turn off time	Q2...Q3	Max. 50 μ s
	Q4...Q7	Max. 300 μ s
Protection against short circuit		Yes
Short circuit output peak current		1.3 A
Automatic rearming after short circuit or overload		Yes, every 1 s
Clamping voltage		Max. 39 Vdc \pm 1 Vdc
Switching frequency	Under resistive load	100 Hz max.
Isolation	Between output and internal logic	500 Vac
Connection type	TM221ME16T	Removable screw terminal blocks
	TM221ME16TG	Removable spring terminal blocks
Connector insertion/removal durability		Over 100 times
Cable	Type	Unshielded
	Length	Max 30 m (98 ft)
NOTE: Refer to Protecting Outputs from Inductive Load Damage, page 78 for additional information concerning output protection.		

Fast Transistor Output Characteristics

The following table describes the characteristics of the TM221M Logic Controller fast transistor outputs:

Characteristic		Value
Number of fast transistor outputs		2 outputs (Q0, Q1)
Number of channel groups		1 common line for Q0...Q7
Output type		Transistor
Logic type		Source
Rated output voltage		24 Vdc
Output voltage range		19.2...28.8 Vdc
Rated output current		0.5 A
Total output current		4 A
Maximum power of filament lamp		12 W max
Derating		see Derating Curve, page 225
Turn on time (10 mA < output current < 100 mA)		Max. 5 μ s
Turn off time (10 mA < output current < 100 mA)		Max. 5 μ s
Protection against short circuit		Yes
Short circuit output peak current		1.3 A max.
Automatic rearming after short circuit or overload		Yes, every 1 s
Protection against reverse polarity		Yes
Clamping voltage		Typ. 39 Vdc \pm 1 Vdc
Maximum output frequency	PLS/PWM/PTO/ FREQGEN	100 kHz
Isolation	Between output and internal logic	500 Vac

Characteristic		Value
Connection type	TM221ME16T	Removable screw terminal blocks
	TM221ME16TG	Removable spring terminal blocks
Connector insertion/removal durability		Over 100 times
Cable	Type	Shielded, including 24 Vdc power supply
	Length	Maximum 3 m (9.84 ft)
<p>NOTE: Refer to Protecting Outputs from Inductive Load Damage, page 78 for additional information concerning output protection.</p>		

Derating Curves

The following figures show the derating curves of the embedded digital outputs:

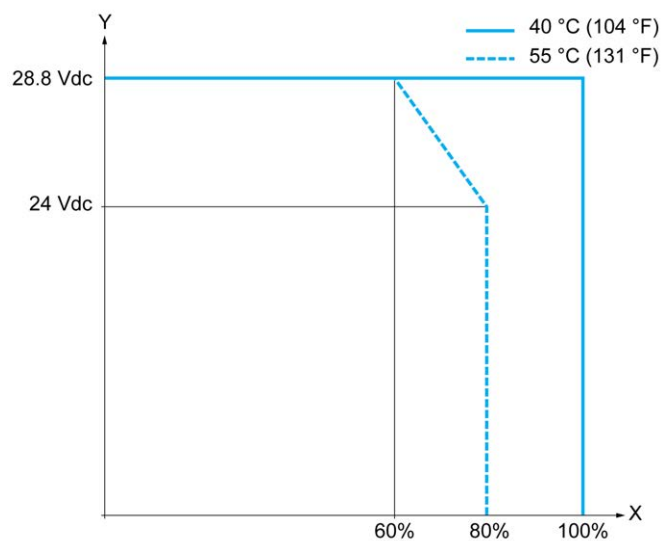

X Output simultaneous ON ratio

Y Output voltage

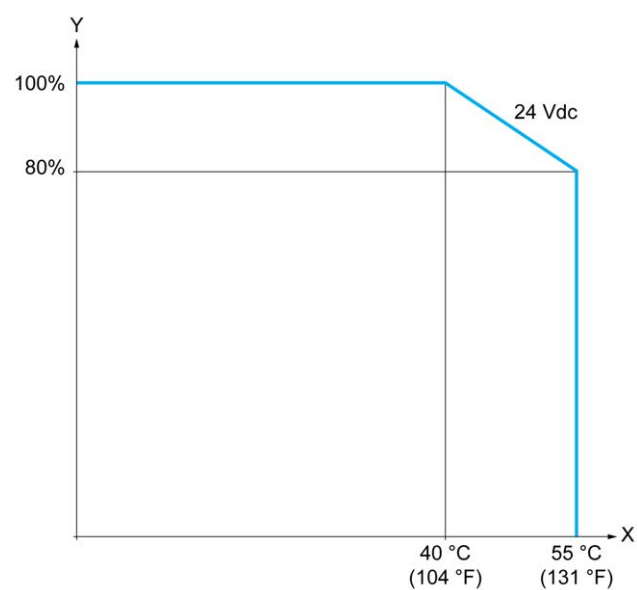

X Ambient temperature

Y Output simultaneous ON ratio

Wiring Diagram

The following figure presents the connection of the outputs to the load:

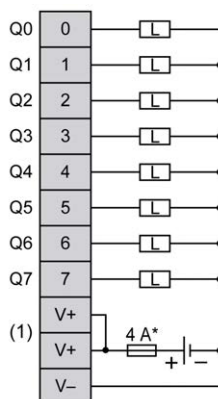

* Type T fuse

(1) The V+ terminals are connected internally.

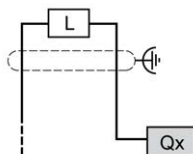

Qx Q0, Q1

TM221ME16T / TM221ME16TG Analog Inputs

Overview

The M221 Logic Controllers have 2 analog inputs embedded.

⚠ DANGER

FIRE HAZARD

- Use only the correct wire sizes for the maximum current capacity of the I/O channels and power supplies.
- For relay output (2 A) wiring, use conductors of at least 0.5 mm² (AWG 20) with a temperature rating of at least 80 °C (176 °F).
- For common conductors of relay output wiring (7 A), or relay output wiring greater than 2 A, use conductors of at least 1.0 mm² (AWG 16) with a temperature rating of at least 80 °C (176 °F).

Failure to follow these instructions will result in death or serious injury.

⚠ WARNING

UNINTENDED EQUIPMENT OPERATION

Do not exceed any of the rated values specified in the environmental and electrical characteristics tables.

Failure to follow these instructions can result in death, serious injury, or equipment damage.

The following procedure describes how to mount the analog cables:

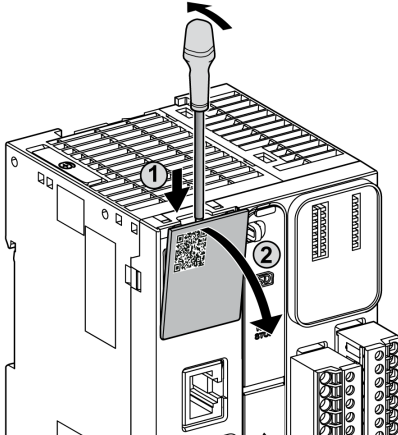
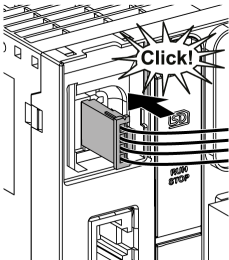
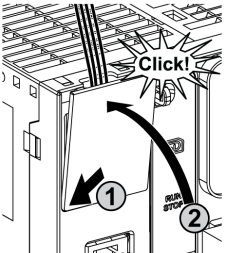
Step	Action
1	Use a screw-driver to remove the protective cover. 
2	Push until you hear it "click". 
3	Replace the protective cover. 

Analog Input Characteristics

The following table describes the characteristics of the M221 Logic Controller with analog inputs:

Characteristic	Voltage Input
Number of maximum inputs	2 inputs
Input type	Single-ended
Rated input range	0...+10 Vdc
Digital resolution	10 bits
Input value of LSB	10 mV
Input impedance	100 kΩ
Input delay time	12 ms
Sample duration time	1 ms per channel + 1 scan time
Accuracy	± 1 % of the full scale

Characteristic		Voltage Input
Noise resistance - maximum temporary deviation during perturbations		± 5 % maximum of the full scale when EMC perturbation is applied to the power and I/O wiring
Isolation	Between input and internal logic	Not isolated
Connection type		Specific connector and cable (supplied)
Connector insertion/removal durability		Over 100 times
Cable	Type	Proprietary (supplied)
	Length	1 m (3.3 ft)

Wiring Diagram

The following figure shows the wiring diagram of the Modicon M221 Logic Controller analog inputs:

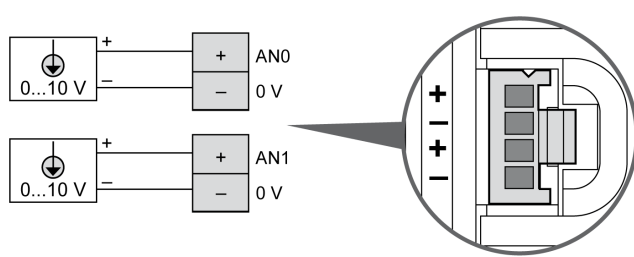

The (-) poles are connected internally.

Pin	Wire Color
AN0	Red
0 V	Black
AN1	Red
0 V	Black

For more information, refer to the Wiring Best Practices, page 74.

TM221M32TK

What's in This Chapter

TM221M32TK Presentation 229
 TM221M32TK Digital Inputs 232
 TM221M32TK Digital Outputs 235
 TM221M32TK Analog Inputs 239

Overview

This chapter describes the TM221M32TK controllers.

TM221M32TK Presentation

Overview

The following features are integrated into the TM221M32TK (HE10) controllers:

- 16 digital inputs
 - 12 regular inputs
 - 4 fast inputs (HSC)
- 16 digital outputs
 - 14 regular transistor outputs
 - 2 fast transistor outputs
- 2 analog inputs
- Communication port
 - 2 serial line ports
 - 1 USB mini-B programming port

Description

The following figure shows the different components of the controller:

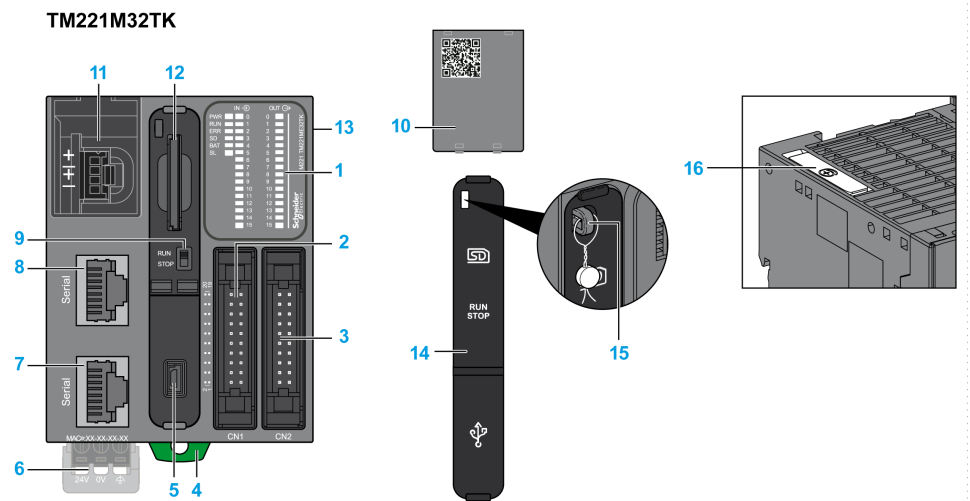

N°	Description	Refer to
1	Status LEDs	–
2	Input HE10 (MIL20) connector	HE10 (MIL 20) connector cable list
3	Output HE10 (MIL20) connector	
4	Clip-on lock for 35 mm (1.38 in.) top hat section rail (DIN-rail)	DIN Rail
5	USB mini-B programming port / For terminal connection to a programming PC (EcoStruxure Machine Expert - Basic)	USB mini-B programming port , page 257
6	24 Vdc power supply	Power supply, page 79
7	Serial line port 2 / RJ45 connector (RS-485)	Serial line 2, page 263
8	Serial line port 1 / RJ45 connector (RS-232 or RS-485)	Serial line 1, page 260
9	Run/Stop switch	Run/Stop switch , page 53
10	Removable analog inputs cover	–
11	2 analog inputs	Analog Inputs, page 239
12	SD Card slot	SD Card Slot, page 55
13	I/O expansion connector	–
14	Protective cover (SD Card slot, Run/Stop switch and USB mini-B programming port)	–
15	Locking hook	–
16	Battery holder	Installing and Replacing the Battery, page 45

Status LEDs

The following figure shows the status LEDs:

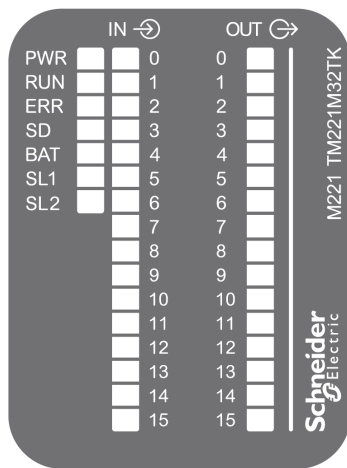

The following table describes the status LEDs:

Label	Function Type	Color	Status	Description		
				Controller States ⁽¹⁾	Prg Port Communication	Application Execution
PWR	Power	Green	On	Indicates that power is applied.		
			Off	Indicates that power is removed.		
RUN	Machine Status	Green	On	Indicates that the controller is running a valid application.		
			Flashing	Indicates that the controller has a valid application that is stopped.		
			Off	Indicates that the controller is not programmed.		

Label	Function Type	Color	Status	Description		
				Controller States ⁽¹⁾	Prg Port Communication	Application Execution
ERR	Error	Red	On*	EXCEPTION	Restricted	NO
			Flashing (with RUN status LED Off)	INTERNAL ERROR	Restricted	NO
			Slow flashing	Minor error detected ⁽²⁾	Yes	Depends on the RUN status LED
			1 single flash	No application	Yes	Yes
SD	SD Card Access, page 55	Green	On	Indicates that the SD card is being accessed.		
			Flashing	Indicates that an error was detected during the SD card operation.		
			Off	Indicates no access (idle) or no card is present.		
BAT	Battery, page 44	Red	On	Indicates that the battery needs to be replaced.		
			Flashing	Indicates that the battery charge is low.		
			Off	Indicates that the battery is OK.		
SL1	Serial line 1, page 260	Green	On	Indicates the status of Serial line 1.		
			Flashing	Indicates activity on Serial line 1.		
			Off	Indicates no serial communication.		
SL2	Serial line 2, page 263	Green	On	Indicates the status of Serial line 2.		
			Flashing	Indicates activity on Serial line 2.		
			Off	Indicates no serial communication.		

* ERR LED is also On during booting process.

(1) For more information about the controller state description, refer to the M221 Logic Controller - Programming Guide (see Modicon M221, Logic Controller, Programming Guide).

(2) The controller detected an error but remains in RUNNING state. The ERR LED on the controller flashes. For more information, refer to M221 Logic Controller - Programming Guide.

Dimensions

The following figure shows the external dimensions of the controller:

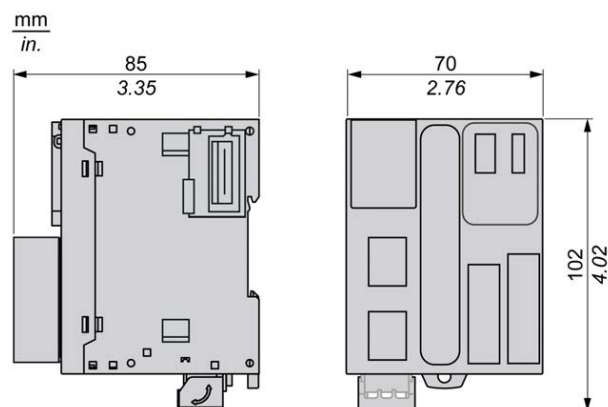

TM221M32TK Digital Inputs

Overview

This M221 Logic Controller has embedded digital inputs:

- 12 regular inputs
- 4 fast inputs which can be used as 100 kHz HSC inputs

For more information, refer to Input Management, page 48.

⚠ DANGER

FIRE HAZARD

- Use only the correct wire sizes for the maximum current capacity of the I/O channels and power supplies.
- For relay output (2 A) wiring, use conductors of at least 0.5 mm² (AWG 20) with a temperature rating of at least 80 °C (176 °F).
- For common conductors of relay output wiring (7 A), or relay output wiring greater than 2 A, use conductors of at least 1.0 mm² (AWG 16) with a temperature rating of at least 80 °C (176 °F).

Failure to follow these instructions will result in death or serious injury.

⚠ WARNING

UNINTENDED EQUIPMENT OPERATION

Do not exceed any of the rated values specified in the environmental and electrical characteristics tables.

Failure to follow these instructions can result in death, serious injury, or equipment damage.

Regular Input Characteristics

The following table describes the characteristics of the TM221M Logic Controller regular inputs:

Characteristic	Value	
Number of regular inputs	12 inputs	
Number of channel groups	1 common line for I0...I7 1 common line for I8...I15	
Input type	Type 1 (IEC/EN 61131-2)	
Logic type	Sink/Source	
Rated input voltage	24 Vdc	
Input voltage range	19.2...28.8 Vdc	
Rated input current	7 mA	
Input impedance	3.4 kΩ	
Input limit values	Voltage at state 1	> 15 Vdc (15...28.8 Vdc)
	Voltage at state 0	< 5 Vdc (0...5 Vdc)
	Current at state 1	> 2.5 mA
	Current at state 0	< 1.0 mA
Derating	see Derating Curve, page 234	

Characteristic		Value
Turn on time		35 μ s + filter value ⁽¹⁾
Turn off time		35 μ s + filter value ⁽¹⁾
Isolation	Between input and internal logic	500 Vac
Connection type		HE10 (MIL 20) connectors
Connector insertion/removal durability		Over 100 times
Cable	Type	Unshielded
	Length	Maximum 30 m (98 ft)
(1) For more information, refer to Integrator Filter Principle, page 48		

Fast Input Characteristics

The following table describes the characteristics of the TM221M Logic Controller fast inputs:

Characteristic		Value
Number of fast inputs		4 inputs (I0, I1, I6, I7)
Number of channel groups		1 common line for I0...I7
Input type		Type 1 (IEC/EN 61131-2)
Logic type		Sink/Source
Rated input voltage		24 Vdc
Input voltage range		19.2...28.8 Vdc
Rated input current		4.5 mA
Input impedance		4.9 k Ω
Input limit values	Voltage at state 1	> 15 Vdc (15...28.8 Vdc)
	Voltage at state 0	< 5 Vdc (0...5 Vdc)
	Current at state 1	> 2.5 mA
	Current at state 0	< 1.0 mA
Derating		see Derating Curve, page 234
Turn on time		5 μ s + filter value ⁽¹⁾
Turn off time		5 μ s + filter value ⁽¹⁾
HSC maximum frequency	Dual Phase	100 kHz
	Single phase	100 kHz
	Frequency Meter	100 kHz
HSC supported operation mode		<ul style="list-style-type: none"> • Dual Phase [Pulse / Direction] • Dual Phase [Quadrature X1] • Dual Phase [Quadrature X2] • Dual Phase [Quadrature X4] • Single Phase • Frequency Meter
Isolation	Between input and internal logic	500 Vac
	Between channel groups	500 Vac
Connection type	TM221M32TK	HE10 (MIL 20) connector
Connector insertion/removal durability		Over 100 times

Characteristic		Value
Cable	Type	Shielded, including the 24 Vdc power supply
	Length	Maximum 10 m (32.8 ft)

(1) For more information, refer to Integrator Filter Principle, page 48

Derating Curves

The following figures show the derating curves of the embedded digital inputs:

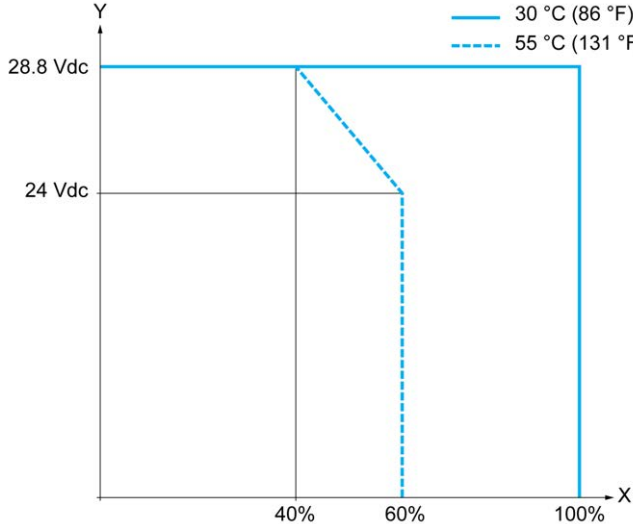

X Input simultaneous ON ratio

Y Input voltage

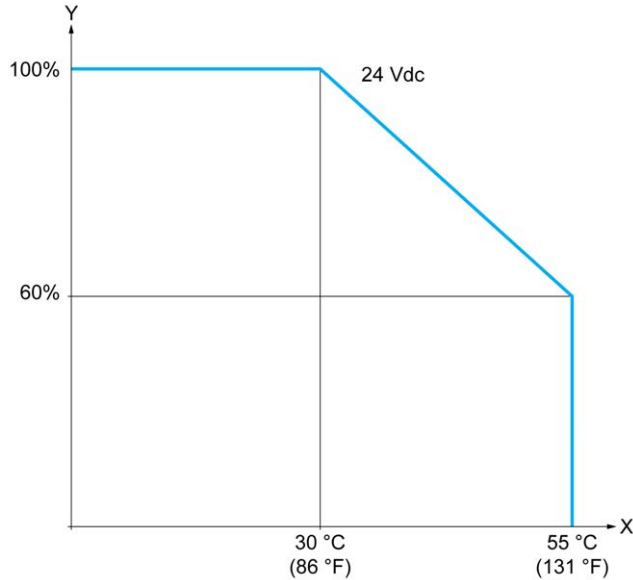

X Ambient temperature

Y Input simultaneous ON ratio

Wiring Diagram with Free-Wire Cable

The following figure presents the connection of the inputs to the sensors:

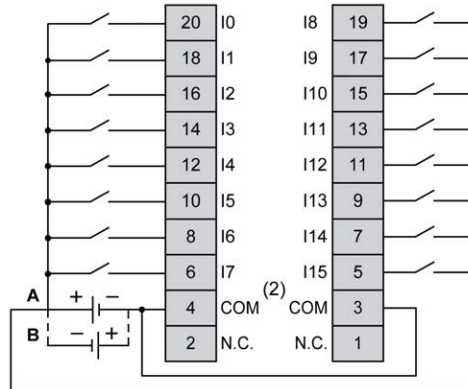

(1) The COM terminals are **not** connected internally.

A Sink wiring (positive logic).

B Source wiring (negative logic).

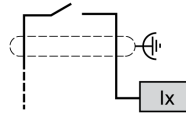

Ix I0, I1, I6, I7

For more information on the cable color for TWDFCW30K/TWDFCW50K, refer to TWDFCW•K Cable Description, page 42.

TM221M32TK Digital Outputs

Overview

The TM221M32TK has 16 digital outputs embedded:

- 14 regular transistor outputs
- 2 fast transistor outputs

For more information, refer to Output Management, page 50.

⚠ DANGER

FIRE HAZARD

- Use only the correct wire sizes for the maximum current capacity of the I/O channels and power supplies.
- For relay output (2 A) wiring, use conductors of at least 0.5 mm² (AWG 20) with a temperature rating of at least 80 °C (176 °F).
- For common conductors of relay output wiring (7 A), or relay output wiring greater than 2 A, use conductors of at least 1.0 mm² (AWG 16) with a temperature rating of at least 80 °C (176 °F).

Failure to follow these instructions will result in death or serious injury.

⚠ WARNING**UNINTENDED EQUIPMENT OPERATION**

Do not exceed any of the rated values specified in the environmental and electrical characteristics tables.

Failure to follow these instructions can result in death, serious injury, or equipment damage.

Regular Transistor Output Characteristics

The following table describes the characteristics of the TM221M Logic Controller regular transistor outputs:

Characteristic		Value
Number of regular transistor outputs		14 regular outputs (Q2...Q15)
Number of channel groups		1 common line for Q0...Q15
Output type		Transistor
Logic type		Source
Rated output voltage		24 Vdc
Output voltage range		19.2...28.8 Vdc
Rated output current		0.1 A
Total output current (Q0...Q15)		1.6 A
Voltage drop		1 Vdc max
Leakage current when switched off		0.1 mA
Maximum power of filament lamp		2.4 W max
Derating		See Derating Curves, page 238
Turn on time	Q2...Q3	Max. 50 μ s
	Q4...Q15	Max. 300 μ s
Turn off time	Q2...Q3	Max. 50 μ s
	Q4...Q15	Max. 300 μ s
Protection against short circuit		Yes
Short circuit output peak current		0.25 A
Automatic rearming after short circuit or overload		Yes, every 1 s
Clamping voltage		Max. 39 Vdc \pm 1 Vdc
Switching frequency	Under resistive load	100 Hz max.
Isolation	Between output and internal logic	500 Vac
Connection type	TM221M32TK	HE10 (MIL 20) connectors
Connector insertion/removal durability		Over 100 times
Cable	Type	Unshielded
	Length	Max 30 m (98 ft)
<p>NOTE: Refer to Protecting Outputs from Inductive Load Damage, page 78 for additional information concerning output protection.</p>		

Fast Transistor Output Characteristics

The following table describes the characteristics of the TM221M Logic Controller fast transistor outputs:

Characteristic		Value
Number of fast transistor outputs		2 outputs (Q0, Q1)
Number of channel groups		1 common line for Q0...Q15
Output type		Transistor
Logic type		Source
Rated output voltage		24 Vdc
Output voltage range		19.2...28.8 Vdc
Rated output current		0.1 A
Total output current (Q0...Q15)		1.6 A
Maximum power of filament lamp		2.4 W max
Derating		See Derating Curves, page 238
Turn on time (10 mA < output current < 100 mA)		Max. 5 μ s
Turn off time (10 mA < output current < 100 mA)		Max. 5 μ s
Protection against short circuit		Yes
Short circuit output peak current		1.3 A max.
Automatic rearming after short circuit or overload		Yes, every 1 s
Protection against reverse polarity		Yes
Clamping voltage		Typ. 39 Vdc +/- 1 Vdc
Maximum output frequency	PWM	100 kHz
	PLS	100 kHz
Isolation	Between output and internal logic	500 Vac
Connection type	TM221M32TK	HE10 (MIL 20) connectors
Connector insertion/removal durability		Over 100 times
Cable	Type	Shielded, including 24 Vdc power supply
	Length	Maximum 3 m (9.84 ft)
<p>NOTE: Refer to Protecting Outputs from Inductive Load Damage, page 78 for additional information concerning output protection.</p>		

Derating Curves

The following figures show the derating curves of the embedded digital outputs:

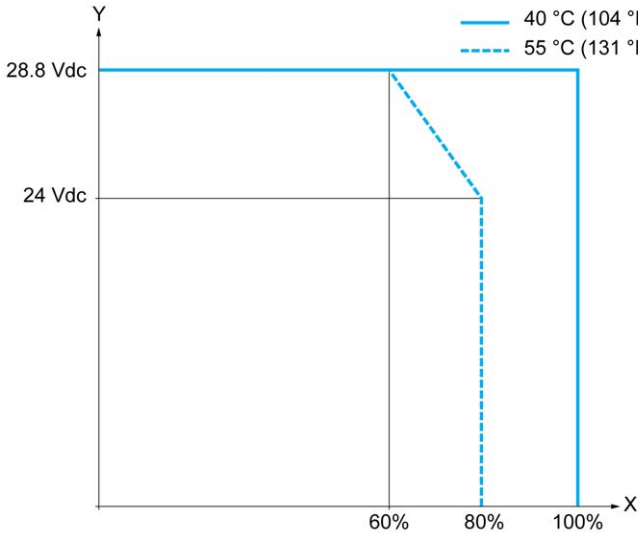

X Output simultaneous ON ratio

Y Output voltage

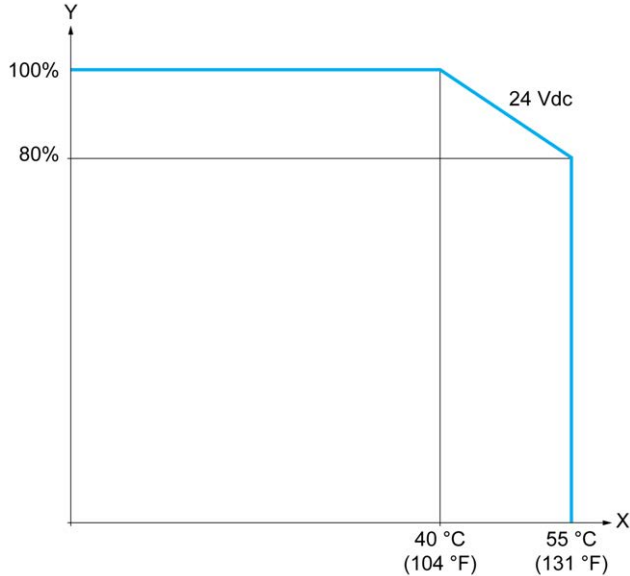

X Ambient temperature

Y Output simultaneous ON ratio

Wiring Diagram with Free-Wire Cable

The following figure presents the connection of the outputs to the load:

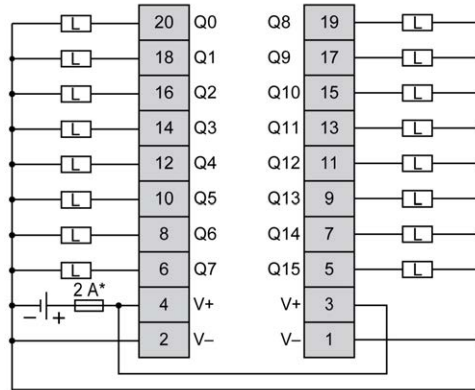

* Type T fuse

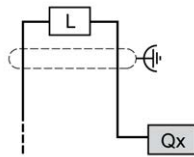

Qx Q0, Q1

For more information on the cable color for TWDFCW30K/TWDFCW50K, refer to TWDFCW••K Cable Description, page 42.

TM221M32TK Analog Inputs

Overview

The M221 Logic Controllers have 2 analog inputs embedded.

⚠ DANGER

FIRE HAZARD

- Use only the correct wire sizes for the maximum current capacity of the I/O channels and power supplies.
- For relay output (2 A) wiring, use conductors of at least 0.5 mm² (AWG 20) with a temperature rating of at least 80 °C (176 °F).
- For common conductors of relay output wiring (7 A), or relay output wiring greater than 2 A, use conductors of at least 1.0 mm² (AWG 16) with a temperature rating of at least 80 °C (176 °F).

Failure to follow these instructions will result in death or serious injury.

⚠ WARNING

UNINTENDED EQUIPMENT OPERATION

Do not exceed any of the rated values specified in the environmental and electrical characteristics tables.

Failure to follow these instructions can result in death, serious injury, or equipment damage.

The following procedure describes how to mount the analog cables:

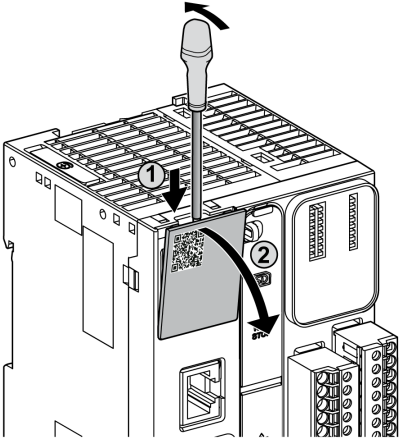
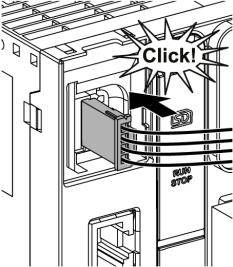
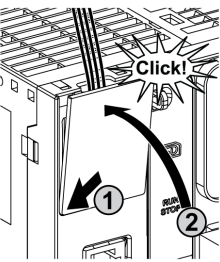
Step	Action
1	Use a screw-driver to remove the protective cover. 
2	Push until you hear it "click". 
3	Replace the protective cover. 

Analog Input Characteristics

The following table describes the characteristics of the M221 Logic Controller with analog inputs:

Characteristic	Voltage Input
Number of maximum inputs	2 inputs
Input type	Single-ended
Rated input range	0...+10 Vdc
Digital resolution	10 bits
Input value of LSB	10 mV
Input impedance	100 kΩ
Input delay time	12 ms
Sample duration time	1 ms per channel + 1 scan time
Accuracy	± 1 % of the full scale

Characteristic		Voltage Input
Noise resistance - maximum temporary deviation during perturbations		± 5 % maximum of the full scale when EMC perturbation is applied to the power and I/O wiring
Isolation	Between input and internal logic	Not isolated
Connection type		Specific connector and cable (supplied)
Connector insertion/removal durability		Over 100 times
Cable	Type	Proprietary (supplied)
	Length	1 m (3.3 ft)

Wiring Diagram

The following figure shows the wiring diagram of the Modicon M221 Logic Controller analog inputs:

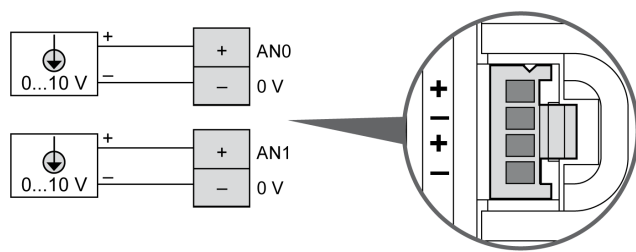

The (-) poles are connected internally.

Pin	Wire Color
AN0	Red
0 V	Black
AN1	Red
0 V	Black

For more information, refer to the *Wiring Best Practices*, page 74.

TM221ME32TK

What's in This Chapter

TM221ME32TK Presentation	242
TM221ME32TK Digital Inputs.....	245
TM221ME32TK Digital Outputs	249
TM221ME32TK Analog Inputs.....	253

Overview

This chapter describes the TM221ME32TK controller.

TM221ME32TK Presentation

Overview

The following features are integrated into the TM221ME32TK (HE 10) controllers:

- 16 digital inputs
 - 12 regular inputs
 - 4 fast inputs (HSC)
- 16 digital outputs
 - 14 regular transistor outputs
 - 2 fast transistor outputs
- 2 analog inputs
- Communication port
 - 1 serial line port
 - 1 USB mini-B programming port
 - 1 Ethernet port

Description

The following figure shows the different components of the controller:

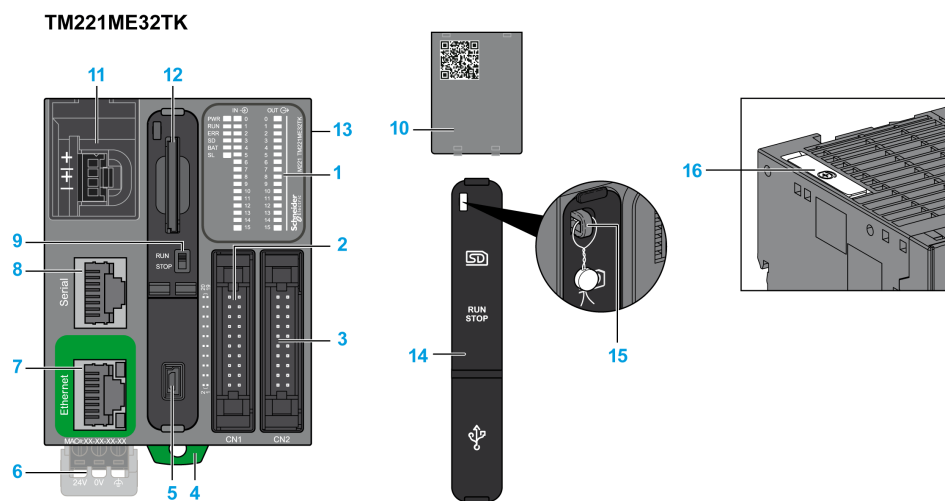

N°	Description	Refer to
1	Status LEDs	–
2	Input HE10 (MIL20) connector	HE10 (MIL 20) connector cable list
3	Output HE10 (MIL20) connector	
4	Clip-on lock for 35 mm (1.38 in.) top hat section rail (DIN-rail)	DIN Rail
5	USB mini-B programming port / For terminal connection to a programming PC (EcoStruxure Machine Expert - Basic)	USB mini-B programming port , page 257
6	24 Vdc power supply	Power supply, page 79
7	Ethernet port / RJ45 connector	Ethernet port, page 258
8	Serial line port 1 / RJ45 connector (RS-232 or RS-485)	Serial line 1, page 260
9	Run/Stop switch	Run/Stop switch , page 53
10	Removable analog inputs cover	–
11	2 analog inputs	Analog Inputs, page 253
12	SD Card slot	SD Card Slot, page 55
13	I/O expansion connector	–
14	Protective cover (SD Card slot, Run/Stop switch and USB mini-B programming port)	–
15	Locking hook	–
16	Battery holder	Installing and Replacing the Battery, page 45

Status LEDs

The following figure shows the status LEDs:

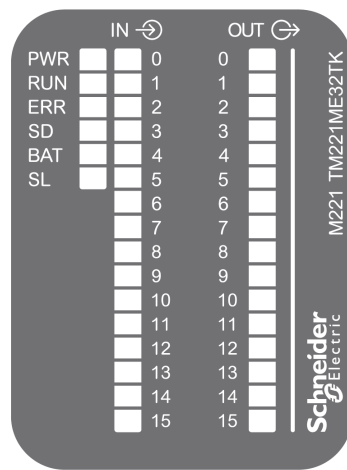

The following table describes the status LEDs:

Label	Function Type	Color	Status	Description		
				Controller States ⁽¹⁾	Prg Port Communication	Application Execution
PWR	Power	Green	On	Indicates that power is applied.		
			Off	Indicates that power is removed.		
RUN	Machine Status	Green	On	Indicates that the controller is running a valid application.		
			Flashing	Indicates that the controller has a valid application that is stopped.		
			Off	Indicates that the controller is not programmed.		
ERR	Error	Red	On*	EXCEPTION	Restricted	NO
			Flashing (with RUN status LED Off)	INTERNAL ERROR	Restricted	NO
			Slow flash	Minor error detected ⁽²⁾	Yes	Depends on the RUN status LED
			1 single flash	No application	Yes	Yes
SD	SD Card Access, page 55	Green	On	Indicates that the SD card is being accessed.		
			Flashing	Indicates that an error was detected during the SD card operation.		
			Off	Indicates no access (idle) or no card is present.		
BAT	Battery, page 44	Red	On	Indicates that the battery needs to be replaced.		
			Flashing	Indicates that the battery charge is low.		
			Off	Indicates that the battery is OK.		
SL	Serial line 1, page 260	Green	On	Indicates the status of Serial line 1.		
			Flashing	Indicates activity on Serial line 1.		
			Off	Indicates no serial communication.		

* ERR LED is also On during booting process.

NOTE: For information about the LEDs integrated into the Ethernet connector, refer to Ethernet Status LEDs, page 260

(1) For more information about the controller state description, refer to the M221 Logic Controller - Programming Guide (see Modicon M221, Logic Controller, Programming Guide).

(2) The controller detected an error but remains in RUNNING state. The ERR LED on the controller flashes. For more information, refer to M221 Logic Controller - Programming Guide.

Dimensions

The following figure shows the external dimension controller:

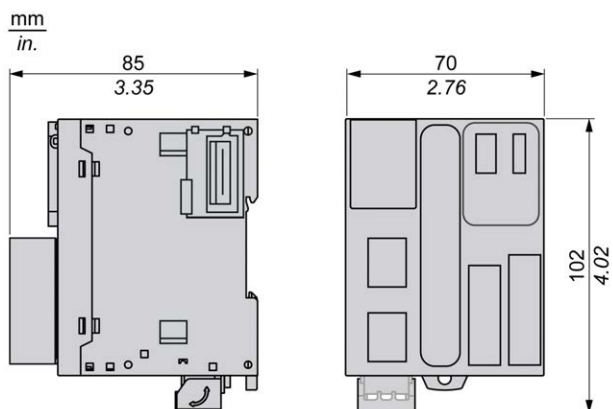

TM221ME32TK Digital Inputs

Overview

This M221 Logic Controller has embedded digital inputs:

- 12 regular inputs
- 4 fast inputs which can be used as 100 kHz HSC inputs

For more information, refer to Input Management, page 48.

DANGER

FIRE HAZARD

- Use only the correct wire sizes for the maximum current capacity of the I/O channels and power supplies.
- For relay output (2 A) wiring, use conductors of at least 0.5 mm² (AWG 20) with a temperature rating of at least 80 °C (176 °F).
- For common conductors of relay output wiring (7 A), or relay output wiring greater than 2 A, use conductors of at least 1.0 mm² (AWG 16) with a temperature rating of at least 80 °C (176 °F).

Failure to follow these instructions will result in death or serious injury.

WARNING

UNINTENDED EQUIPMENT OPERATION

Do not exceed any of the rated values specified in the environmental and electrical characteristics tables.

Failure to follow these instructions can result in death, serious injury, or equipment damage.

Regular Input Characteristics

The following table describes the characteristics of the TM221M Logic Controller regular inputs:

Characteristic		Value
Number of regular inputs		12 inputs
Number of channel groups		1 common line for I0...I7 1 common line for I8...I15
Input type		Type 1 (IEC/EN 61131-2)
Logic type		Sink/Source
Rated input voltage		24 Vdc
Input voltage range		19.2...28.8 Vdc
Rated input current		7 mA
Input impedance		3.4 k Ω
Input limit values	Voltage at state 1	> 15 Vdc (15...28.8 Vdc)
	Voltage at state 0	< 5 Vdc (0...5 Vdc)
	Current at state 1	> 2.5 mA
	Current at state 0	< 1.0 mA
Derating		see Derating Curve, page 247
Turn on time		35 μ s + filter value ⁽¹⁾
Turn off time		I2...I5: 35 μ s ⁽¹⁾ I8...I15: 100 μ s ⁽¹⁾
Isolation	Between input and internal logic	500 Vac
Connection type		HE10 (MIL 20) connectors
Connector insertion/removal durability		Over 100 times
Cable	Type	Unshielded
	Length	Maximum 30 m (98 ft)
(1) For more information, refer to Integrator Filter Principle, page 48		

Fast Input Characteristics

The following table describes the characteristics of the TM221M Logic Controller fast inputs:

Characteristic		Value
Number of fast inputs		4 inputs (I0, I1, I6, I7)
Number of channel groups		1 common line for I0...I7
Input type		Type 1 (IEC/EN 61131-2)
Logic type		Sink/Source
Rated input voltage		24 Vdc
Input voltage range		19.2...28.8 Vdc
Rated input current		4.5 mA
Input impedance		4.9 kΩ
Input limit values	Voltage at state 1	> 15 Vdc (15...28.8 Vdc)
	Voltage at state 0	< 5 Vdc (0...5 Vdc)
	Current at state 1	> 2.5 mA
	Current at state 0	< 1.0 mA
Derating		see Derating Curve, page 248
Turn on time		5 μs + filter value ⁽¹⁾
Turn off time		5 μs + filter value ⁽¹⁾
HSC maximum frequency	Dual Phase	100 kHz
	Single phase	100 kHz
	Frequency Meter	100 kHz
HSC supported operation mode		<ul style="list-style-type: none"> • Dual Phase [Pulse / Direction] • Dual Phase [Quadrature X1] • Dual Phase [Quadrature X2] • Dual Phase [Quadrature X4] • Single Phase • Frequency Meter
Isolation	Between input and internal logic	500 Vac
	Between channel groups	500 Vac
Connection type	TM221ME32TK	HE10 (MIL 20) connector
Connector insertion/removal durability		Over 100 times
Cable	Type	Shielded, including the 24 Vdc power supply
	Length	Maximum 10 m (32.8 ft)
(1) For more information, refer to Integrator Filter Principle, page 48		

Derating Curves

The following figures show the derating curves of the embedded digital inputs:

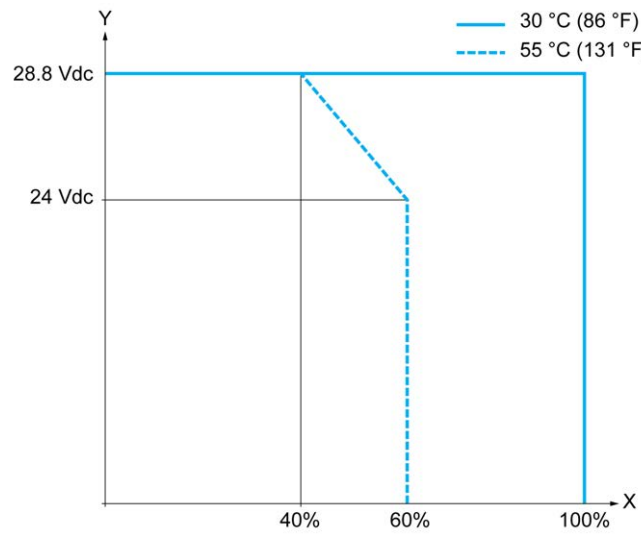

X Input simultaneous ON ratio

Y Input voltage

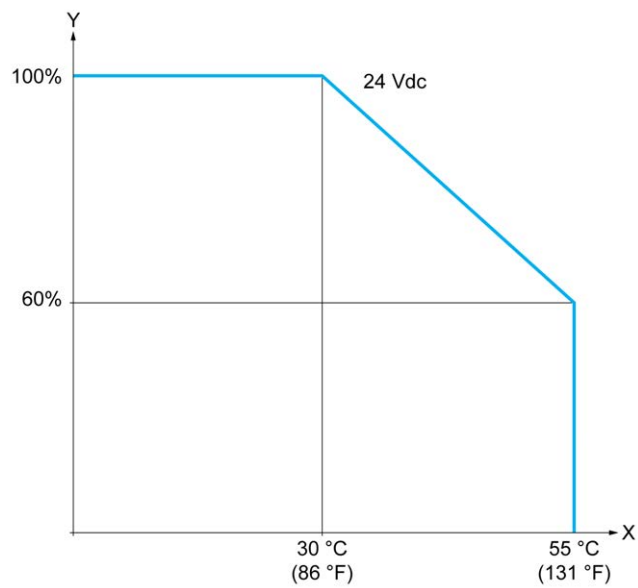

X Ambient temperature

Y Input simultaneous ON ratio

Wiring Diagram with Free-Wire Cable

The following figure presents the connection of the inputs to the sensors:

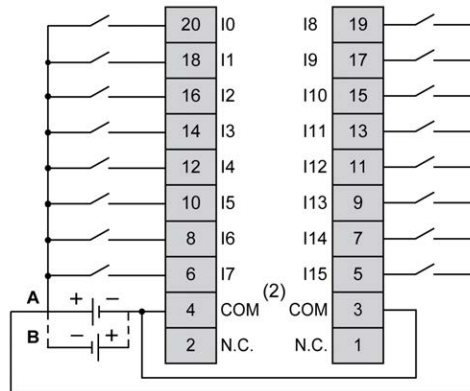

(1) The COM terminals are **not** connected internally.

A Sink wiring (positive logic).

B Source wiring (negative logic).

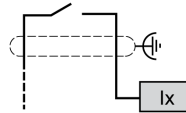

Ix I0, I1, I6, I7

For more information on the cable color for TWDFCW30K/TWDFCW50K, refer to TWDFCW•K Cable Description, page 43.

TM221ME32TK Digital Outputs

Overview

The TM221ME32TK has 16 digital outputs embedded:

- 14 regular transistor outputs
- 2 fast transistor outputs

For more information, refer to Output Management, page 50.

⚠ DANGER

FIRE HAZARD

- Use only the correct wire sizes for the maximum current capacity of the I/O channels and power supplies.
- For relay output (2 A) wiring, use conductors of at least 0.5 mm² (AWG 20) with a temperature rating of at least 80 °C (176 °F).
- For common conductors of relay output wiring (7 A), or relay output wiring greater than 2 A, use conductors of at least 1.0 mm² (AWG 16) with a temperature rating of at least 80 °C (176 °F).

Failure to follow these instructions will result in death or serious injury.

⚠ WARNING**UNINTENDED EQUIPMENT OPERATION**

Do not exceed any of the rated values specified in the environmental and electrical characteristics tables.

Failure to follow these instructions can result in death, serious injury, or equipment damage.

Regular Transistor Output Characteristics

The following table describes the characteristics of the TM221M Logic Controller regular transistor outputs:

Characteristic		Value
Number of regular transistor outputs		14 regular outputs (Q2...Q15)
Number of channel groups		1 common line for Q0...Q15
Output type		Transistor
Logic type		Source
Rated output voltage		24 Vdc
Output voltage range		19.2...28.8 Vdc
Rated output current		0.1 A
Total output current (Q0...Q15)		1.6 A
Voltage drop		1 Vdc max
Leakage current when switched off		0.1 mA
Maximum power of filament lamp		2.4 W max
Derating		See Derating Curves, page 252
Turn on time	Q2...Q3	Max. 50 μ s
	Q4...Q15	Max. 300 μ s
Turn off time	Q2...Q3	Max. 50 μ s
	Q4...Q15	Max. 300 μ s
Protection against short circuit		Yes
Short circuit output peak current		0.25 A
Automatic rearming after short circuit or overload		Yes, every 1 s
Clamping voltage		Max. 39 Vdc \pm 1 Vdc
Switching frequency	Under resistive load	100 Hz max.
Isolation	Between output and internal logic	500 Vac
Connection type	TM221ME32TK	HE10 (MIL 20) connectors
Connector insertion/removal durability		Over 100 times
Cable	Type	Unshielded
	Length	Max 30 m (98 ft)
<p>NOTE: Refer to Protecting Outputs from Inductive Load Damage, page 78 for additional information concerning output protection.</p>		

Fast Transistor Output Characteristics

The following table describes the characteristics of the TM221M Logic Controller fast transistor outputs:

Characteristic		Value
Number of fast transistor outputs		2 outputs (Q0, Q1)
Number of channel groups		1 common line for Q0...Q15
Output type		Transistor
Logic type		Source
Rated output voltage		24 Vdc
Output voltage range		19.2...28.8 Vdc
Rated output current		0.1 A
Total output current (Q0...Q15)		1.6 A
Maximum power of filament lamp		2.4 W max
Derating		See Derating Curves, page 252
Turn on time (10 mA < output current < 100 mA)		Max. 5 μ s
Turn off time (10 mA < output current < 100 mA)		Max. 5 μ s
Protection against short circuit		Yes
Short circuit output peak current		1.3 A max.
Automatic rearming after short circuit or overload		Yes, every 1 s
Protection against reverse polarity		Yes
Clamping voltage		Typ. 39 Vdc +/- 1 Vdc
Maximum output frequency	PLS/PWM/PTO/ FREQGEN	100 kHz
Isolation	Between output and internal logic	500 Vac
Connection type	TM221ME32TK	HE10 (MIL 20) connectors
Connector insertion/removal durability		Over 100 times
Cable	Type	Shielded, including 24 Vdc power supply
	Length	Maximum 3 m (9.84 ft)
<p>NOTE: Refer to Protecting Outputs from Inductive Load Damage, page 78 for additional information concerning output protection.</p>		

Derating Curves

The following figures show the derating curves of the embedded digital outputs:

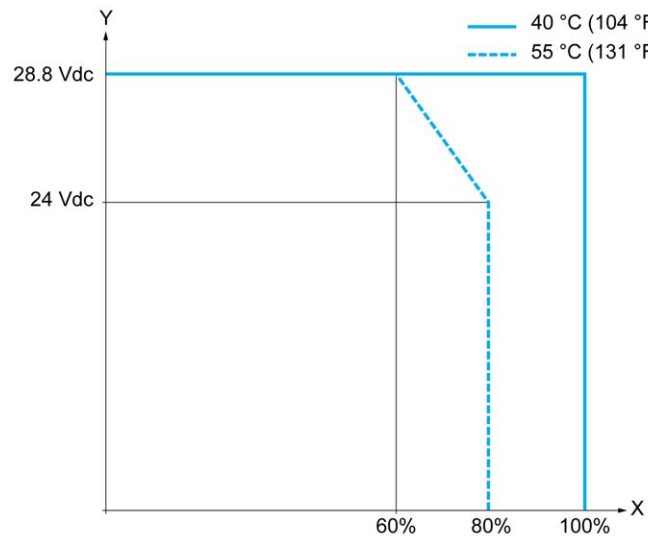

X Output simultaneous ON ratio

Y Output voltage

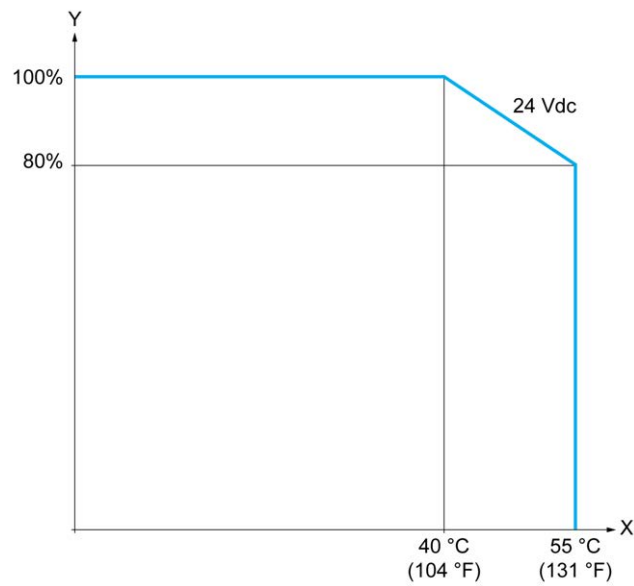

X Ambient temperature

Y Output simultaneous ON ratio

Wiring Diagram with Free-Wire Cable

The following figure presents the connection of the outputs to the load:

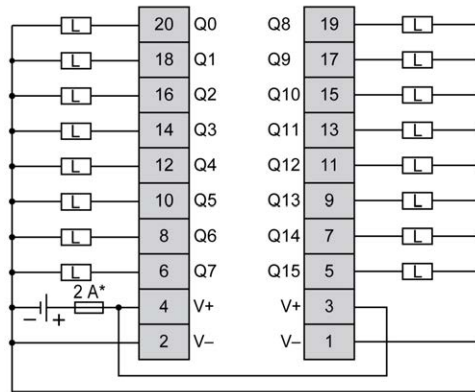

* Type T fuse

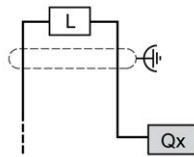

Qx Q0, Q1

For more information on the cable color for TWDFCW30K/TWDFCW50K, refer to TWDFCW••K Cable Description, page 42.

TM221ME32TK Analog Inputs

Overview

The M221 Logic Controllers have 2 analog inputs embedded.

⚠ DANGER

FIRE HAZARD

- Use only the correct wire sizes for the maximum current capacity of the I/O channels and power supplies.
- For relay output (2 A) wiring, use conductors of at least 0.5 mm² (AWG 20) with a temperature rating of at least 80 °C (176 °F).
- For common conductors of relay output wiring (7 A), or relay output wiring greater than 2 A, use conductors of at least 1.0 mm² (AWG 16) with a temperature rating of at least 80 °C (176 °F).

Failure to follow these instructions will result in death or serious injury.

⚠ WARNING

UNINTENDED EQUIPMENT OPERATION

Do not exceed any of the rated values specified in the environmental and electrical characteristics tables.

Failure to follow these instructions can result in death, serious injury, or equipment damage.

The following procedure describes how to mount the analog cables:

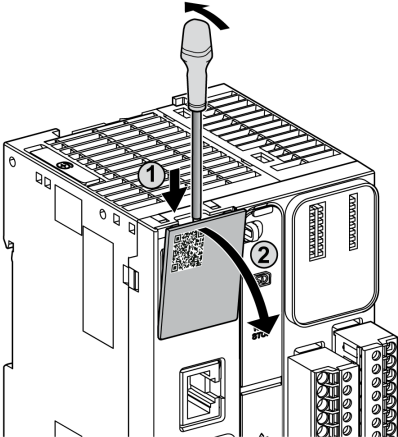
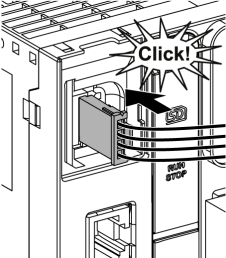
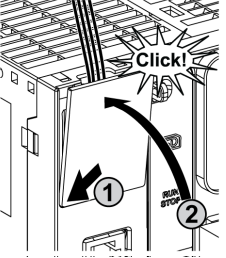
Step	Action
1	Use a screw-driver to remove the protective cover. 
2	Push until you hear it "click". 
3	Replace the protective cover. 

Analog Input Characteristics

The following table describes the characteristics of the M221 Logic Controller with analog inputs:

Characteristic	Voltage Input
Number of maximum inputs	2 inputs
Input type	Single-ended
Rated input range	0...+10 Vdc
Digital resolution	10 bits
Input value of LSB	10 mV
Input impedance	100 kΩ
Input delay time	12 ms
Sample duration time	1 ms per channel + 1 scan time
Accuracy	± 1 % of the full scale

Characteristic		Voltage Input
Noise resistance - maximum temporary deviation during perturbations		± 5 % maximum of the full scale when EMC perturbation is applied to the power and I/O wiring
Isolation	Between input and internal logic	Not isolated
Connection type		Specific connector and cable (supplied)
Connector insertion/removal durability		Over 100 times
Cable	Type	Proprietary (supplied)
	Length	1 m (3.3 ft)

Wiring Diagram

The following figure shows the wiring diagram of the Modicon M221 Logic Controller analog inputs:

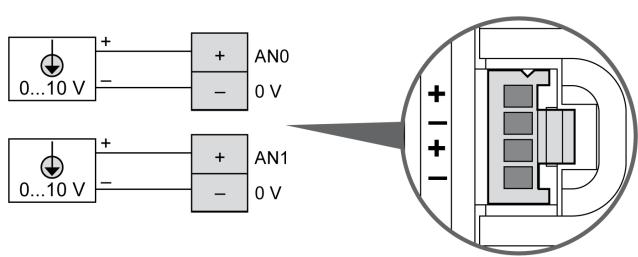

The (-) poles are connected internally.

Pin	Wire Color
AN0	Red
0 V	Black
AN1	Red
0 V	Black

For more information, refer to the *Wiring Best Practices*, page 74.

Modicon M221 Logic Controller Communication

What's in This Part

Integrated Communication Ports	257
Connecting the M221 Logic Controller to a PC.....	266

Integrated Communication Ports

What's in This Chapter

USB Mini-B Programming Port	257
Ethernet Port	258
Serial Line 1	260
Serial Line 2	263

USB Mini-B Programming Port

Overview

The USB Mini-B Port is the programming port you can use to connect a PC with a USB host port using EcoStruxure Machine Expert - Basic software. Using a typical USB cable, this connection is suitable for quick updates of the program or short duration connections to perform maintenance and inspect data values. It is not suitable for long-term connections such as commissioning or monitoring without the use of specially adapted cables to help minimize electromagnetic interference.

⚠ WARNING

UNINTENDED EQUIPMENT OPERATION OR INOPERABLE EQUIPMENT

- You must use a shielded USB cable such as a BMX XCAUSBH0•• secured to the functional ground (FE) of the system for any long-term connection.
- Do not connect more than one controller or bus coupler at a time using USB connections.
- Do not use the USB port(s), if so equipped, unless the location is known to be non-hazardous.

Failure to follow these instructions can result in death, serious injury, or equipment damage.

The following figure shows the location of the USB Mini-B programming port on the TM221C Logic Controller:

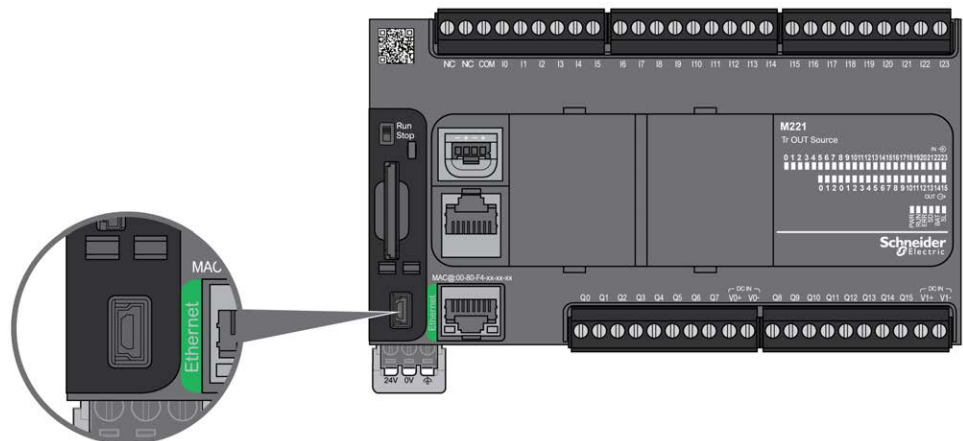

The following figure shows the location of the USB Mini-B programming port on the TM221M Logic Controller:

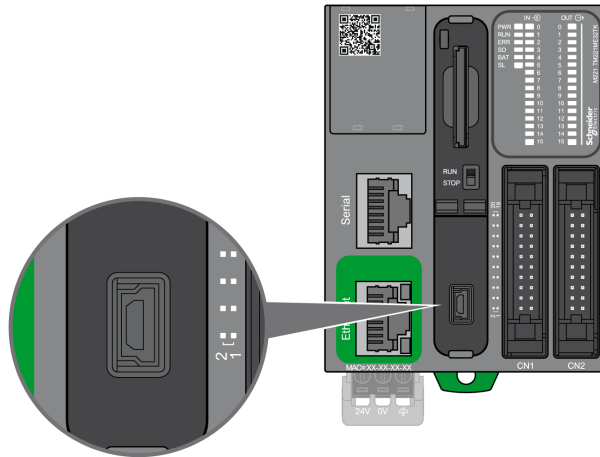

Characteristics

This table describes the characteristics of the USB Mini-B programming port:

Parameter	USB Programming Port
Function	Compatible with USB 2.0
Connector type	Mini-B
Isolation	None
Cable type	Shielded

Ethernet Port

Overview

The TM221•E•••• are equipped with an Ethernet communication port.

The following figure presents the location of the Ethernet port on the TM221C Logic Controller:

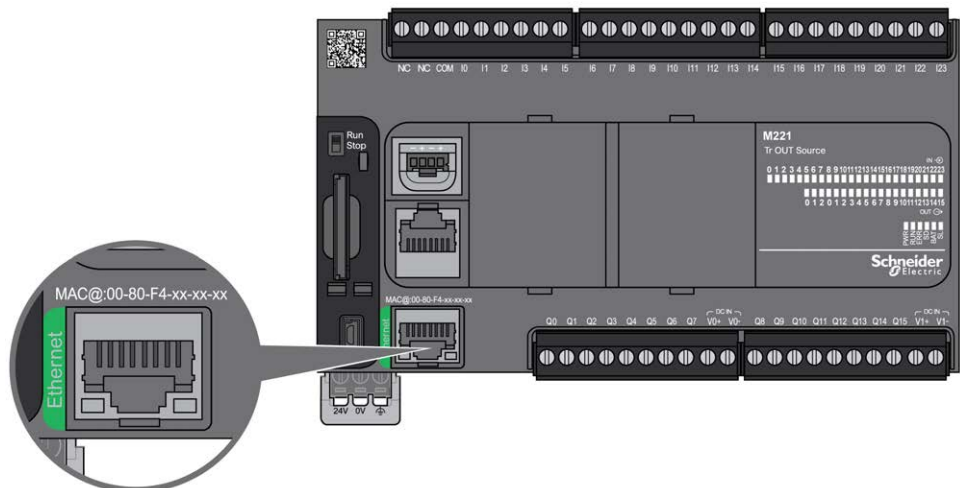

The following figure presents the location of the Ethernet port on the TM221M Logic Controller:

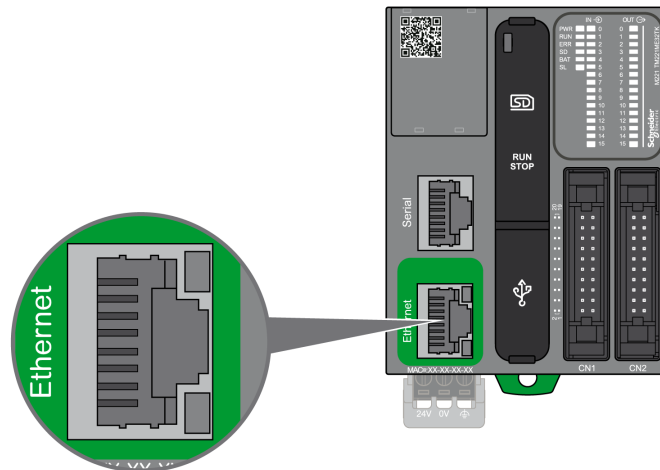

Characteristics

The following table describes Ethernet characteristics:

Characteristic	Description
Function	Modbus TCP/IP
Connector type	RJ45
Driver	<ul style="list-style-type: none"> 10 M half duplex (auto negotiation) 100 M full duplex (auto negotiation)
Cable type	Shielded
Automatic cross-over detection	Yes

Pin Assignment

The following figure presents the RJ45 Ethernet connector pin assignment:

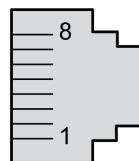

The following table describes the RJ45 Ethernet connector pins:

Pin N°	Signal
1	TD+
2	TD-
3	RD+
4	-
5	-
6	RD-
7	-
8	-

NOTE: The controller supports the MDI/MDIX auto-crossover cable function. It is not necessary to use special Ethernet crossover cables to connect devices directly to this port (connections without an Ethernet hub or switch).

Status LEDs

The following figures show the RJ45 connector status LEDs:

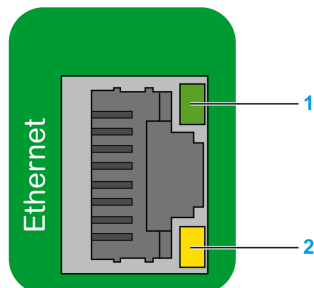

The following table describes the Ethernet status LEDs:

Label	Description	LED		
		Color	Status	Description
1: ACT	Ethernet activity	Green	Off	No activity, or logic controller is connected to a hub.
			Flashing	Activity
2: LINK	Ethernet link	Yellow	Off	No link
			On	Link

A change in the value of system bits %S34, %S35, or %S36 may provoke a reinitialization of the Ethernet channel. As a consequence, the Ethernet channel may not be available for several seconds after a change in the values of these System Bits.

Serial Line 1

Overview

The serial line 1:

- can be used to communicate with devices supporting the Modbus protocol as either master or slave, ASCII protocol (printer, modem...).
- provides a 5 Vdc power distribution.

The following figure shows the location of the serial line 1 port on the TM221C Logic Controller:

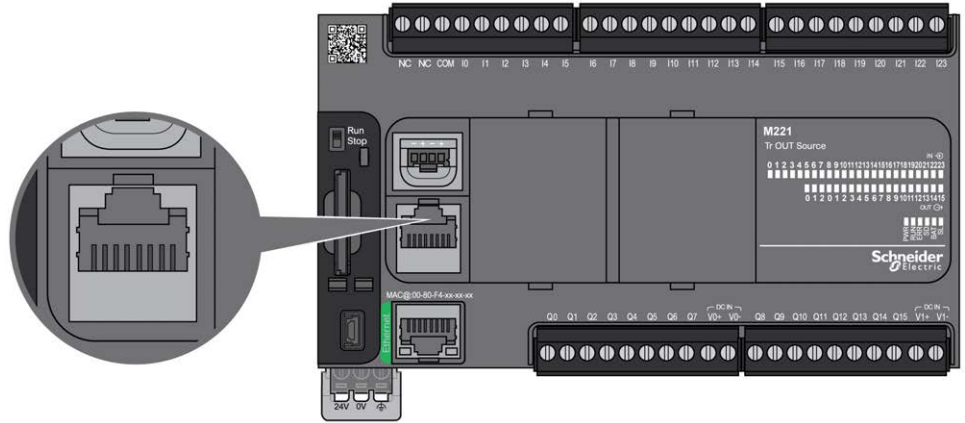

The following figure shows the location of the serial line 1 port on the TM221M Logic Controller:

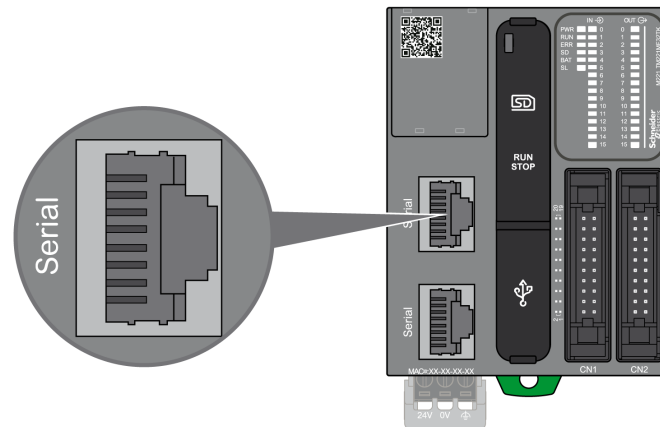

Characteristics

Characteristic		Description
Function		RS485 or RS232 software configured
Connector type		RJ45
Isolation		Non-isolated
Maximum baud rate		1200 up to 115 200 bps
Cable	Type	Shielded
	Maximum length (between the controller and an isolated junction box)	15 m (49 ft) for RS485 3 m (9.84 ft) for RS232
Polarization		No ⁽¹⁾
5 Vdc power supply for RS485		Yes
<p>(1) TM221 embedded SL1 and embedded SL2 contains fixed internal high impedance bias network resistors (4.7 kΩ). Do not use external line termination resistors (standard 150 Ω) without additional external low impedance line polarization resistors (standard 450 Ω...650 Ω) to secure a proper idle voltage state of minimum 200 mV between the D1 and D0 data lines.</p>		

NOTE: Some devices provide voltage on RS485 serial connections. Do not connect these voltage lines to your controller as they may damage the controller serial port electronics and render the serial port inoperable.

NOTICE**INOPERABLE EQUIPMENT**

Use only the VW3A8306R** serial cable to connect RS485 devices to your controller.

Failure to follow these instructions can result in equipment damage.

Pin Assignment

The following figure shows the pins of the RJ45 connector:

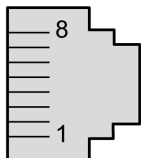

The table below describes the pin assignment of the RJ45 connector:

Pin	RS232	RS485
1	RxD	N.C.
2	TxD	N.C.
3	RTS	N.C.
4	N.C.	D1
5	N.C.	D0
6	CTS	N.C.
7	N.C.*	5 Vdc
8	Common	Common

* 5 Vdc delivered by the controller. Do not connect.

CTS: Clear To Send

N.C.: No Connection

RTS: Ready To Send

RxD: Received Data

TxD: Transmitted Data

⚠ WARNING**UNINTENDED EQUIPMENT OPERATION**

Do not connect wires to unused terminals and/or terminals indicated as "No Connection (N.C.)".

Failure to follow these instructions can result in death, serious injury, or equipment damage.

Status LED

The following figure shows the serial line 1 status LED of the TM221C Logic Controller:



The following figure shows the serial line 1 status LED of the TM221M Logic Controller:

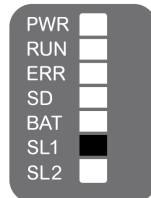

The table below describes the status LED of the serial line 1:

Label	Description	LED		
		Color	Status	Description
SL1	Serial Line 1	Green	On	Indicates the activity of the serial line 1
			Off	Indicates no serial communication

Serial Line 2

Overview

The serial line 2 is used to communicate with devices supporting the Modbus protocol as either a master or slave and ASCII Protocol (printer, modem...) and supports RS485 and terminal block.

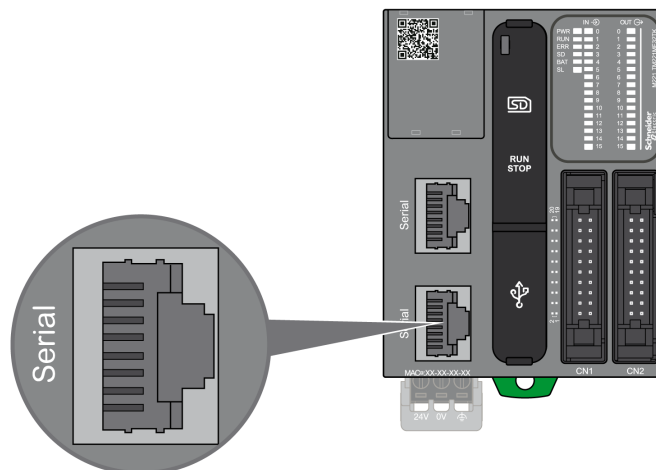

Characteristics

Characteristic		Description
Function		RS485 software configured
Connector type		RJ45
Isolation		Non-isolated
Maximum baud rate		1200 up to 115 200 bps
Cable	Type	Shielded
	Maximum length	15 m (49 ft) for RS485
Polarization		No ⁽¹⁾
5 Vdc power supply for RS485		No
<p>(1) TM221 embedded SL1 and embedded SL2 contains fixed internal high impedance bias network resistors (4.7 kΩ). Do not use external line termination resistors (standard 150 Ω) without additional external low impedance line polarization resistors (standard 450 Ω...650 Ω) to secure a proper idle voltage state of minimum 200 mV between the D1 and D0 data lines.</p>		

Pin Assignment

The following figure presents the pins of the RJ45 connector:

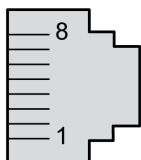

The table below describes the pin assignment for RS485:

Pin	RS485	Description
1	N.C.	No connection
2	N.C.	No connection
3	N.C.	No connection
4	D1	Modbus SL: D1 (+/B) RS-485 2-wire
5	D0	Modbus SL: D0 (-/A) RS-485 2-wire
6	N.C.	No connection
7	N.C.	No connection
8	Common	Common

⚠ WARNING

UNINTENDED EQUIPMENT OPERATION

Do not connect wires to unused terminals and/or terminals indicated as “No Connection (N.C.)”.

Failure to follow these instructions can result in death, serious injury, or equipment damage.

Status LED

The following graphic presents the status LED:

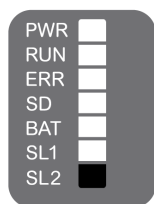

The table below describes the serial line 2 status LED:

Label	Description	LED		
		Color	Status	Description
SL2	Serial Line 2	Green	On	Indicates the activity of the serial line 2.
			Off	Indicates no serial communication.

Connecting the M221 Logic Controller to a PC

What's in This Chapter

Connecting the Controller to a PC..... 266

Connecting the Controller to a PC

Overview

To transfer, run, and monitor the applications, connect the controller to a computer, that has EcoStruxure Machine Expert - Basic 1.0 or later installed, using either a USB cable or an Ethernet connection (for those references that support an Ethernet port).

NOTICE

INOPERABLE EQUIPMENT

Always connect the communication cable to the PC before connecting it to the controller.

Failure to follow these instructions can result in equipment damage.

USB Mini-B Port Connection

Cable Reference	Details
BMXXCAUSBH018	Grounded and shielded, this USB cable is suitable for long duration connections.
TCSXCNAMUM3P	This USB cable is suitable for short duration connections such as quick updates or retrieving data values.

NOTE: You can only connect 1 controller or any other device associated with EcoStruxure Machine Expert - Basic and its component to the PC at any one time.

⚠ WARNING

INSUFFICIENT POWER FOR USB DOWNLOAD

Do not use a USB cable longer than 3 m (9.8 ft) for USB powered download.

Failure to follow these instructions can result in death, serious injury, or equipment damage.

The USB Mini-B Port is the programming port you can use to connect a PC with a USB host port using EcoStruxure Machine Expert - Basic software. Using a typical USB cable, this connection is suitable for quick updates of the program or short duration connections to perform maintenance and inspect data values. It is not suitable for long-term connections such as commissioning or monitoring without the use of specially adapted cables to help minimize electromagnetic interference.

⚠ WARNING

UNINTENDED EQUIPMENT OPERATION OR INOPERABLE EQUIPMENT

- You must use a shielded USB cable such as a BMX XCAUSBH0•• secured to the functional ground (FE) of the system for any long-term connection.
- Do not connect more than one controller or bus coupler at a time using USB connections.
- Do not use the USB port(s), if so equipped, unless the location is known to be non-hazardous.

Failure to follow these instructions can result in death, serious injury, or equipment damage.

The communication cable should be connected to the PC first to minimize the possibility of electrostatic discharge affecting the controller.

The following illustration shows the USB connection to a PC on a TM221C Logic Controller:

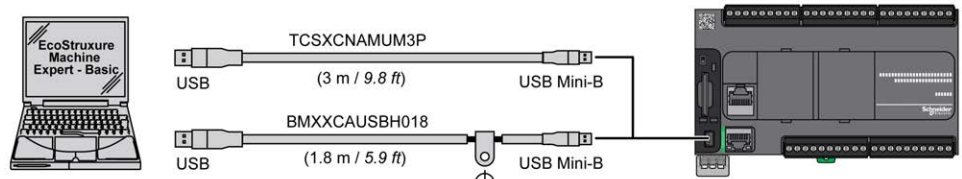

The following illustration shows the USB connection to a PC on a TM221M Logic Controller:

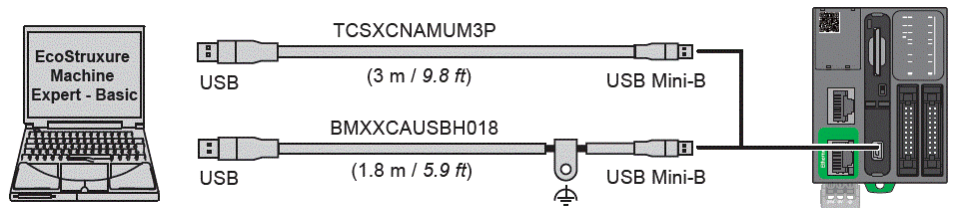

To connect the USB cable to your controller, follow the steps below:

Step	Action
1	<p>1a. If making a long-term connection using the cable BMXXCAUSBH018, or other cable with a ground shield connection, be sure to securely connect the shield connector to the functional ground (FE) or protective ground (PE) of your system before connecting the cable to your controller and your PC.</p> <p>1b. If making a short-term connection using the cable TCSXCNAMUM3P or other non-grounded USB cable, proceed to step 2.</p>
2	Connect your USB cable to the computer.
3	Open the protective cover for the USB Mini-B slot on the controller.
4	Connect the Mini-B connector of your USB cable to the controller USB connector.

Ethernet Port Connection

You can also connect the controller to a PC using an Ethernet cable.

The following illustration shows the Ethernet connection to a PC on a TM221C Logic Controller:

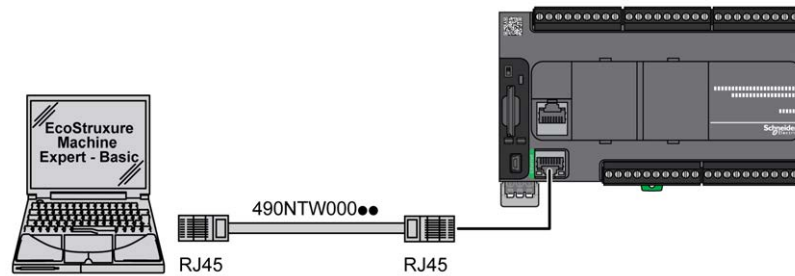

The following illustration shows the Ethernet connection to a PC on a TM221M Logic Controller:

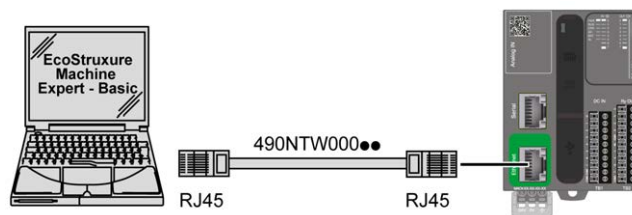

To connect the controller to the PC, do the following:

Step	Action
1	Connect your Ethernet cable to the PC.
2	Connect your Ethernet cable to the Ethernet port on the controller.

Glossary

A

analog input:

Converts received voltage or current levels into numerical values. You can store and process these values within the logic controller.

ASCII:

(American standard code for Information Interchange) A protocol for representing alphanumeric characters (letters, numbers, certain graphics, and control characters).

B

bps:

(bit per second) A definition of transmission rate, also given in conjunction with multiplier kilo (kbps) and mega (mbps).

C

CFC:

(continuous function chart) A graphical programming language (an extension of the IEC 61131-3 standard) based on the function block diagram language that works like a flowchart. However, no networks are used and free positioning of graphic elements is possible, which allows feedback loops. For each block, the inputs are on the left and the outputs on the right. You can link the block outputs to the inputs of other blocks to create complex expressions.

continuous function chart language:

A graphical programming language (an extension of the IEC61131-3 standard) based on the function block diagram language that works like a flowchart. However, no networks are used and free positioning of graphic elements is possible, which allows feedback loops. For each block, the inputs are on the left and the outputs on the right. You can link the block outputs to inputs of other blocks to create complex expressions.

CTS:

(clear to send) A data transmission signal and acknowledges the RDS signal from the transmitting station.

CW/CCW:

ClockWise / Counter ClockWise

D

DIN:

(Deutsches Institut für Normung) A German institution that sets engineering and dimensional standards.

E

EIA rack:

(electronic industries alliance rack) A standardized (EIA 310-D, IEC 60297, and DIN 41494 SC48D) system for mounting various electronic modules in a stack or rack that is 19 inches (482.6 mm) wide.

EN:

EN identifies one of many European standards maintained by CEN (*European Committee for Standardization*), CENELEC (*European Committee for Electrotechnical Standardization*), or ETSI (*European Telecommunications Standards Institute*).

F**FBD:**

(*function block diagram*) One of 5 languages for logic or control supported by the standard IEC 61131-3 for control systems. Function block diagram is a graphically oriented programming language. It works with a list of networks, where each network contains a graphical structure of boxes and connection lines, which represents either a logical or arithmetic expression, the call of a function block, a jump, or a return instruction.

FE:

(*functional Earth*) A common grounding connection to enhance or otherwise allow normal operation of electrically sensitive equipment (also referred to as functional ground in North America).

In contrast to a protective Earth (protective ground), a functional earth connection serves a purpose other than shock protection, and may normally carry current. Examples of devices that use functional earth connections include surge suppressors and electromagnetic interference filters, certain antennas, and measurement instruments.

FreqGen:

(*frequency generator*) A function that generates a square wave signal with programmable frequency.

G**GRAFCET:**

The functioning of a sequential operation in a structured and graphic form.

This is an analytical method that divides any sequential control system into a series of steps, with which actions, transitions, and conditions are associated.

H**HE10:**

Rectangular connector for electrical signals with frequencies below 3 MHz, complying with IEC 60807-2.

HSC:

(*high-speed counter*) A function that counts pulses on the controller or on expansion module inputs.

I**IEC 61131-3:**

Part 3 of a 3-part IEC standard for industrial automation equipment. IEC 61131-3 is concerned with controller programming languages and defines 2 graphical and 2 textual programming language standards. The graphical programming languages are ladder diagram and function block diagram. The textual programming languages include structured text and instruction list.

IEC:

(international electrotechnical commission) A non-profit and non-governmental international standards organization that prepares and publishes international standards for electrical, electronic, and related technologies.

IL:

(instruction list) A program written in the language that is composed of a series of text-based instructions executed sequentially by the controller. Each instruction includes a line number, an instruction code, and an operand (refer to IEC 61131-3).

instruction list language:

A program written in the instruction list language that is composed of a series of text-based instructions executed sequentially by the controller. Each instruction includes a line number, an instruction code, and an operand (see IEC 61131-3).

IP 20:

(ingress protection) The protection classification according to IEC 60529 offered by an enclosure, shown by the letter IP and 2 digits. The first digit indicates 2 factors: helping protect persons and for equipment. The second digit indicates helping protect against water. IP 20 devices help protect against electric contact of objects larger than 12.5 mm, but not against water.

L**ladder diagram language:**

A graphical representation of the instructions of a controller program with symbols for contacts, coils, and blocks in a series of rungs executed sequentially by a controller (see IEC 61131-3).

LD:

(ladder diagram) A graphical representation of the instructions of a controller program with symbols for contacts, coils, and blocks in a series of rungs executed sequentially by a controller (refer to IEC 61131-3).

M**Modbus:**

The protocol that allows communications between many devices connected to the same network.

N**NEMA:**

(national electrical manufacturers association) The standard for the performance of various classes of electrical enclosures. The NEMA standards cover corrosion resistance, ability to help protect from rain, submersion, and so on. For IEC member countries, the IEC 60529 standard classifies the ingress protection rating for enclosures.

P**PE:**

(Protective Earth) A common grounding connection to help avoid the hazard of electric shock by keeping any exposed conductive surface of a device at earth potential. To avoid possible voltage drop, no current is allowed to flow in this conductor (also referred to as *protective ground* in North America or as an equipment grounding conductor in the US national electrical code).

PTO:

(pulse train outputs) A fast output that oscillates between off and on in a fixed 50-50 duty cycle, producing a square wave form. PTO is especially well suited for applications such as stepper motors, frequency converters, and servo motor control, among others.

PWM:

(pulse width modulation) A fast output that oscillates between off and on in an adjustable duty cycle, producing a rectangular wave form (though you can adjust it to produce a square wave).

R**RJ45:**

A standard type of 8-pin connector for network cables defined for Ethernet.

RS-232:

A standard type of serial communication bus, based on 3 wires (also known as EIA RS-232C or V.24).

RS-485:

A standard type of serial communication bus, based on 2 wires (also known as EIA RS-485).

RTS:

(request to send) A data transmission signal and CTS signal that acknowledges the RTS from the destination node.

RxD:

The line that receives data from one source to another.

S**SFC:**

(sequential function chart) A language that is composed of steps with associated actions, transitions with associated logic condition, and directed links between steps and transitions. (The SFC standard is defined in IEC 848. It is IEC 61131-3 compliant.)

ST:

(structured text) A language that includes complex statements and nested instructions (such as iteration loops, conditional executions, or functions). ST is compliant with IEC 61131-3.

T**terminal block:**

(terminal block) The component that mounts in an electronic module and provides electrical connections between the controller and the field devices.

TxD:

The line that sends data from one source to another.

Index

A

accessories 41

B

bus coupler
specifications 39

C

certifications and standards 62
Communication Ports 257
 Ethernet Port 258
 Serial Line 1 260
 Serial Line 2 263
 USB Programming Port 257
connecting the controller to a PC 266

D

DIN rail 69

E

Electrical Requirements
 Installation 74
Electromagnetic Susceptibility 62
Environmental Characteristics 60

F

fallback
 configuring modes 52
Filter
 Bounce Filter 48

G

grounding 85

I

inductive load 78
Input Management 48
Installation 60
 Electrical Requirements 74
 Logic Controller Installation 63
intended use 8

L

Latching 48
Logic Controller Installation
 Installation 63

M

M221
 TM221C16R 89
 TM221C16T 95

TM221C16U 101
TM221C24R 107
TM221C24T 113
TM221C24U 119
TM221C40R 125
TM221C40T 133
TM221C40U 141
TM221CE16R 92
TM221CE16T 98
TM221CE16U 104
TM221CE24R 110
TM221CE24T 116
TM221CE24U 122
TM221CE40R 129
TM221CE40T 137
TM221CE40U 144
TM221M16R / TM221M16RG 178
TM221M16T 202
TM221M32TK 229
TM221ME16R / TM221ME16RG 190
TM221ME16T / TM221ME16TG 216
TM221ME32TK 242
mounting positions 64, 66

O

output management 50
output protection 78

P

Power Supply 79, 82
presentation
 TM221M16R / TM221M16RG 178
 TM221M16T / TM221M16TG 202
 TM221M32TK 229
 TM221ME16R / TM221ME16RG 190
 TM221ME16T / TM221ME16TG 216
 TM221ME32TK 242

Q

qualification of personnel 7

R

real time clock 44
Run/Stop 53

S

SD Card 55
Serial Line 1
 Communication Ports 260
Serial Line 2
 Communication Ports 263
short-circuit or over-current on relay outputs 53
short-circuit or over-current on sink transistor
 outputs 53
short-circuit or over-current on source transistor
 outputs 52
specifications
 modules 37

T

Tesys modules	
specifications	37
TM221C features	17
TM221C16R	89
TM221C16T	95
TM221C16U	101
TM221C24R	107
TM221C24T	113
TM221C24U	119
TM221C40R	125
TM221C40T	133
TM221C40U	141
TM221CE16R	92
TM221CE16T	98
TM221CE16U	104
TM221CE24R	110
TM221CE24T	116
TM221CE24U	122
TM221CE40R	129
TM221CE40T	137
TM221CE40U	144
TM221M features	21
TMC2 cartridges	40

U

USB Programming Port	
Communication Ports	257

W

wiring	74
--------------	----

Schneider Electric
35 rue Joseph Monier
92500 Rueil Malmaison
France

+ 33 (0) 1 41 29 70 00

www.se.com

As standards, specifications, and design change from time to time,
please ask for confirmation of the information given in this publication.

© 2024 Schneider Electric. All rights reserved.

EIO0000003313.03

Modicon TMH2GDB

Remote Graphic Display

User Guide

09/2020



The information provided in this documentation contains general descriptions and/or technical characteristics of the performance of the products contained herein. This documentation is not intended as a substitute for and is not to be used for determining suitability or reliability of these products for specific user applications. It is the duty of any such user or integrator to perform the appropriate and complete risk analysis, evaluation and testing of the products with respect to the relevant specific application or use thereof. Neither Schneider Electric nor any of its affiliates or subsidiaries shall be responsible or liable for misuse of the information contained herein. If you have any suggestions for improvements or amendments or have found errors in this publication, please notify us.

You agree not to reproduce, other than for your own personal, noncommercial use, all or part of this document on any medium whatsoever without permission of Schneider Electric, given in writing. You also agree not to establish any hypertext links to this document or its content. Schneider Electric does not grant any right or license for the personal and noncommercial use of the document or its content, except for a non-exclusive license to consult it on an "as is" basis, at your own risk. All other rights are reserved.

All pertinent state, regional, and local safety regulations must be observed when installing and using this product. For reasons of safety and to help ensure compliance with documented system data, only the manufacturer should perform repairs to components.

When devices are used for applications with technical safety requirements, the relevant instructions must be followed.

Failure to use Schneider Electric software or approved software with our hardware products may result in injury, harm, or improper operating results.

Failure to observe this information can result in injury or equipment damage.

© 2020 Schneider Electric. All rights reserved.

Table of Contents



	Safety Information	5
	About the Book	7
Chapter 1	Presentation	13
	Description	14
	Technical Presentation	16
	Certifications and Standards	18
	Compatibility of The Remote Graphic Display	19
Chapter 2	Installation	21
	Installation and Maintenance Requirements	22
	Dimensions and Clearances	24
	Mounting	26
	Connecting the Remote Graphic Display	29
	Updating the Firmware	35
Chapter 3	How to Use the Remote Graphic Display	37
	Description	38
	Navigation	39
	Password Protection	41
Chapter 4	Setup Menu Functionality	43
	Setup Menu Presentation	44
	Controller Setup Menu	45
	Controller State Menu	47
	Alarm Menu	49
	Data Table Menu	51
Chapter 5	Creating an Operator Interface with EcoStruxure Machine Expert - Basic	55
	Prerequisite	56
	EcoStruxure Machine Expert - Basic Display Tab	58
	General Properties	60
	Add/Delete a Page	62

Configure a Page	71
Export/Import a Page	74
Actions	75
Alarm Definition	77
Glossary	79
Index	83

Safety Information



Important Information

NOTICE

Read these instructions carefully, and look at the equipment to become familiar with the device before trying to install, operate, service, or maintain it. The following special messages may appear throughout this documentation or on the equipment to warn of potential hazards or to call attention to information that clarifies or simplifies a procedure.



The addition of this symbol to a “Danger” or “Warning” safety label indicates that an electrical hazard exists which will result in personal injury if the instructions are not followed.



This is the safety alert symbol. It is used to alert you to potential personal injury hazards. Obey all safety messages that follow this symbol to avoid possible injury or death.

DANGER

DANGER indicates a hazardous situation which, if not avoided, **will result in death** or serious injury.

WARNING

WARNING indicates a hazardous situation which, if not avoided, **could result in death** or serious injury.

CAUTION

CAUTION indicates a hazardous situation which, if not avoided, **could result** in minor or moderate injury.

NOTICE

NOTICE is used to address practices not related to physical injury.

PLEASE NOTE

Electrical equipment should be installed, operated, serviced, and maintained only by qualified personnel. No responsibility is assumed by Schneider Electric for any consequences arising out of the use of this material.

A qualified person is one who has skills and knowledge related to the construction and operation of electrical equipment and its installation, and has received safety training to recognize and avoid the hazards involved.

About the Book



At a Glance

Document Scope

Use this document to learn how to:

- Connect your Remote Graphic Display to your controller.
- Commission and maintain your Remote Graphic Display.
- Operate your Remote Graphic Display interface with EcoStruxure Machine Expert - Basic.

NOTE: Read and understand this document and all related documents before installing, operating, or maintaining your Remote Graphic Display.

Validity Note

This document has been updated for the release of EcoStruxure™ Machine Expert - Basic V1.1. For product compliance and environmental information (RoHS, REACH, PEP, EOL, etc.), go to www.schneider-electric.com/green-premium.

The technical characteristics of the devices described in the present document also appear online. To access the information online:

Step	Action
1	Go to the Schneider Electric home page www.schneider-electric.com .
2	In the Search box type the reference of a product or the name of a product range. <ul style="list-style-type: none">• Do not include blank spaces in the reference or product range.• To get information on grouping similar modules, use asterisks (*).
3	If you entered a reference, go to the Product Datasheets search results and click on the reference that interests you. If you entered the name of a product range, go to the Product Ranges search results and click on the product range that interests you.
4	If more than one reference appears in the Products search results, click on the reference that interests you.
5	Depending on the size of your screen, you may need to scroll down to see the data sheet.
6	To save or print a data sheet as a .pdf file, click Download XXX product datasheet .

The characteristics that are presented in the present document should be the same as those characteristics that appear online. In line with our policy of constant improvement, we may revise content over time to improve clarity and accuracy. If you see a difference between the document and online information, use the online information as your reference.

Related Documents

Title of Documentation	Reference Number
EcoStruxure Machine Expert - Basic - Operating Guide	<u>EIO0000003281 (ENG)</u> <u>EIO0000003282 (FRE)</u> <u>EIO0000003283 (GER)</u> <u>EIO0000003284 (SPA)</u> <u>EIO0000003285 (ITA)</u> <u>EIO0000003286 (CHS)</u> <u>EIO0000003287 (POR)</u> <u>EIO0000003288 (TUR)</u>
EcoStruxure Machine Expert - Basic Generic Functions - Library Guide	<u>EIO0000003289 (ENG)</u> <u>EIO0000003290 (FRE)</u> <u>EIO0000003291 (GER)</u> <u>EIO0000003292 (SPA)</u> <u>EIO0000003293 (ITA)</u> <u>EIO0000003294 (CHS)</u> <u>EIO0000003295 (POR)</u> <u>EIO0000003296 (TUR)</u>

You can download these technical publications and other technical information from our website at <https://www.se.com/ww/en/download/> .

Product Related Information

DANGER

HAZARD OF ELECTRIC SHOCK, EXPLOSION OR ARC FLASH

- Disconnect all power from all equipment including connected devices prior to removing any covers or doors, or installing or removing any accessories, hardware, cables, or wires except under the specific conditions specified in the appropriate hardware guide for this equipment.
- Always use a properly rated voltage sensing device to confirm the power is off where and when indicated.
- Replace and secure all covers, accessories, hardware, cables, and wires and confirm that a proper ground connection exists before applying power to the unit.
- Use only the specified voltage when operating this equipment and any associated products.

Failure to follow these instructions will result in death or serious injury.

This equipment has been designed to operate outside of any hazardous location. Only install this equipment in zones known to be free of a hazardous atmosphere.

DANGER

POTENTIAL FOR EXPLOSION

Install and use this equipment in non-hazardous locations only.

Failure to follow these instructions will result in death or serious injury.

WARNING

LOSS OF CONTROL

- The designer of any control scheme must consider the potential failure modes of control paths and, for certain critical control functions, provide a means to achieve a safe state during and after a path failure. Examples of critical control functions are emergency stop and overtravel stop, power outage and restart.
- Separate or redundant control paths must be provided for critical control functions.
- System control paths may include communication links. Consideration must be given to the implications of unanticipated transmission delays or failures of the link.
- Observe all accident prevention regulations and local safety guidelines.¹
- Each implementation of this equipment must be individually and thoroughly tested for proper operation before being placed into service.

Failure to follow these instructions can result in death, serious injury, or equipment damage.

¹ For additional information, refer to NEMA ICS 1.1 (latest edition), "Safety Guidelines for the Application, Installation, and Maintenance of Solid State Control" and to NEMA ICS 7.1 (latest edition), "Safety Standards for Construction and Guide for Selection, Installation and Operation of Adjustable-Speed Drive Systems" or their equivalent governing your particular location.

WARNING

UNINTENDED EQUIPMENT OPERATION

- Only use software approved by Schneider Electric for use with this equipment.
- Update your application program every time you change the physical hardware configuration.

Failure to follow these instructions can result in death, serious injury, or equipment damage.

Terminology Derived from Standards

The technical terms, terminology, symbols and the corresponding descriptions in this manual, or that appear in or on the products themselves, are generally derived from the terms or definitions of international standards.

In the area of functional safety systems, drives and general automation, this may include, but is not limited to, terms such as *safety*, *safety function*, *safe state*, *fault*, *fault reset*, *malfunction*, *failure*, *error*, *error message*, *dangerous*, etc.

Among others, these standards include:

Standard	Description
EN 61131-2:2007	Programmable controllers, part 2: Equipment requirements and tests.
ISO 13849-1:2008	Safety of machinery: Safety related parts of control systems. General principles for design.
EN 61496-1:2013	Safety of machinery: Electro-sensitive protective equipment. Part 1: General requirements and tests.
ISO 12100:2010	Safety of machinery - General principles for design - Risk assessment and risk reduction
EN 60204-1:2006	Safety of machinery - Electrical equipment of machines - Part 1: General requirements
EN 1088:2008 ISO 14119:2013	Safety of machinery - Interlocking devices associated with guards - Principles for design and selection
ISO 13850:2006	Safety of machinery - Emergency stop - Principles for design
EN/IEC 62061:2005	Safety of machinery - Functional safety of safety-related electrical, electronic, and electronic programmable control systems
IEC 61508-1:2010	Functional safety of electrical/electronic/programmable electronic safety-related systems: General requirements.
IEC 61508-2:2010	Functional safety of electrical/electronic/programmable electronic safety-related systems: Requirements for electrical/electronic/programmable electronic safety-related systems.
IEC 61508-3:2010	Functional safety of electrical/electronic/programmable electronic safety-related systems: Software requirements.
IEC 61784-3:2008	Digital data communication for measurement and control: Functional safety field buses.
2006/42/EC	Machinery Directive
2014/30/EU	Electromagnetic Compatibility Directive
2014/35/EU	Low Voltage Directive

In addition, terms used in the present document may tangentially be used as they are derived from other standards such as:

Standard	Description
IEC 60034 series	Rotating electrical machines
IEC 61800 series	Adjustable speed electrical power drive systems
IEC 61158 series	Digital data communications for measurement and control – Fieldbus for use in industrial control systems

Finally, the term *zone of operation* may be used in conjunction with the description of specific hazards, and is defined as it is for a *hazard zone* or *danger zone* in the *Machinery Directive (2006/42/EC)* and *ISO 12100:2010*.

NOTE: The aforementioned standards may or may not apply to the specific products cited in the present documentation. For more information concerning the individual standards applicable to the products described herein, see the characteristics tables for those product references.

Chapter 1

Presentation

Introduction

This chapter provides information related to the description, technical presentation, certifications and standards of the Remote Graphic Display.

What Is in This Chapter?

This chapter contains the following topics:

Topic	Page
Description	14
Technical Presentation	16
Certifications and Standards	18
Compatibility of The Remote Graphic Display	19

Description

Overview

The Remote Graphic Display is a local control unit. It is used in conjunction with the Modicon M221 Logic Controller for monitoring, commissioning, operating, and maintenance activities.

System Description

When connecting the Remote Graphic Display to your logic controller, you can access the **Setup menu** (*see page 43*) page.

You can also define customized pages (*see page 55*) with EcoStruxure Machine Expert - Basic.

The Remote Graphic Display can be connected to your logic controller by the serial line (**Serial** or **Serial 1**). For more information, refer to Connecting the Remote Graphic Display (*see page 29*).

Physical Description

This illustration presents the delivery content for a Remote Graphic Display:

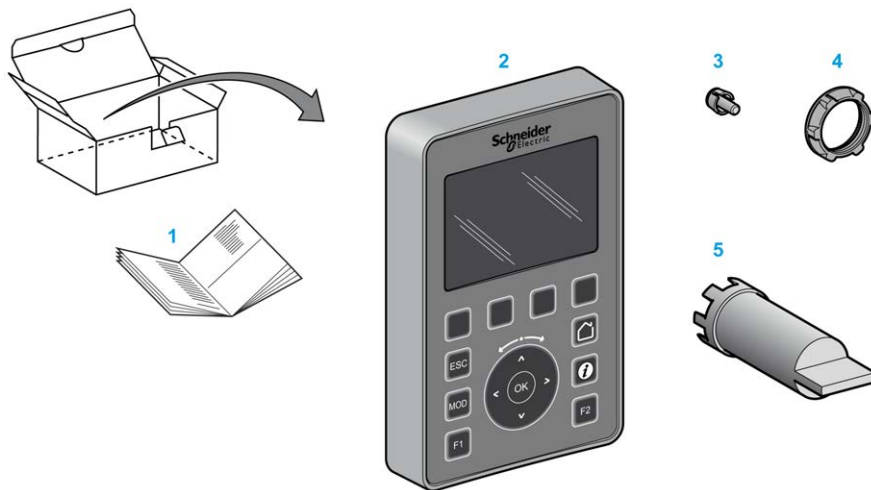

- 1 Remote Graphic Display Instruction Sheet
- 2 Remote Graphic Display
- 3 Anti-rotation tee
- 4 Installation nut
- 5 Socket wrench (ZB5AZ905), tightening tool for the installation nut

Remote Graphic Display Description

This illustration presents the Remote Graphic Display:

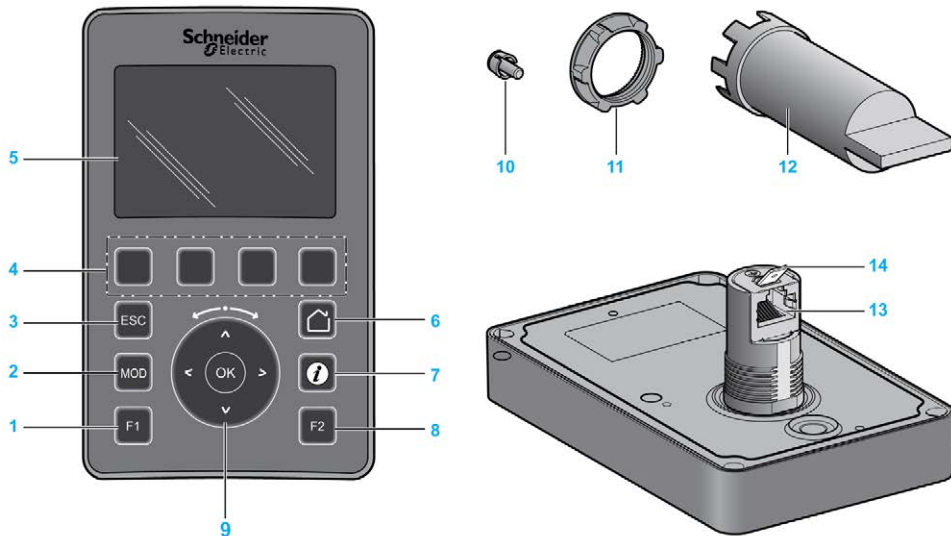

- 1 **F1** key
- 2 **MOD** key
- 3 **ESC** key
- 4 **R1 to R4** keys
- 5 **Graphic screen**
- 6 **Home** key
- 7 **Information** key
- 8 **F2** key
- 9 Touch wheel/**OK**/Arrows
- 10 Anti-rotation tee
- 11 Installation nut
- 12 Socket wrench (ZB5AZ905)
- 13 RJ45 serial line (RS-485)
- 14 Connector for functional ground (earth)

Technical Presentation

Enclosure Requirements

The Remote Graphic Display components are designed as Zone B, Class A industrial equipment according to IEC/CISPR Publication 11. If they are used in environments other than those described in these standards, or in environments that do not meet the specifications in this manual, the ability to meet electromagnetic compatibility requirements in the presence of conducted and/or radiated interference may be reduced.

All Remote Graphic Display components meet European Community (CE) requirements for open equipment as defined by IEC/EN 61131-2.

Environmental Characteristics

This equipment meets CE requirements as indicated in the table below. This equipment is intended for use in a pollution degree 2 industrial environment.

⚠ WARNING
UNINTENDED EQUIPMENT OPERATION
Do not exceed any of the rated values specified in the environmental and electrical characteristics tables.
Failure to follow these instructions can result in death, serious injury, or equipment damage.

Characteristic		Specification
Standard compliance	IEC/EN 61131-2 IEC/EN 61010-2-201	
Ambient operating temperature		-15...50 °C (5...122 °F)
Storage temperature		-40...70 °C (-40...158 °F)
Relative humidity	Transport and storage	95 % (non-condensing)
	Operation	
Pollution degree	IEC/EN 60664-1	2
Protection degree	IEC/EN 61131-2	Front face: IP65 (when properly installed as instructed) Back face: IP20
Corrosion immunity		Atmosphere free from corrosive gases
Operating altitude		0...2000 m (0...6560 ft)
Storage altitude		0...2000 m (0...6560 ft)
Vibration resistance		2 g 3...150 hz maximum 1.5 mm
Mechanical shock resistance		147 m/s ² (482.285 ft/s ²), 15 g for 11 ms duration

Electromagnetic Susceptibility

The Remote Graphic Display components meet electromagnetic susceptibility specifications as indicated in this table:

Characteristic	Designed to specification	Range	
Electrostatic discharge	IEC/EN 61000-4-2	8 kV (air discharge) 4 kV (contact discharge)	
Radiated electromagnetic field	IEC/EN 61000-4-3	10 V/m (80 MHz...1 GHz) 3 V/m (1.4 GHz...2 GHz) 1 V/m (2...3 GHz)	
Magnetic field	IEC/EN 61000-4-8	30 A/m 50 Hz, 60 Hz	
Fast transient burst	IEC/EN 61000-4-4	1 kV	
Surge immunity	IEC/EN 61000-4-5 IEC/EN 61131-2	CM ⁽¹⁾	DM ⁽²⁾
		0.5 kV	0.5 kV
Induced electromagnetic field	IEC/EN 61000-4-6	10 Vrms (0.15...80 MHz)	
Conducted emission	IEC/EN 55011 (IEC/CISPR Publication 11)	DC power line: <ul style="list-style-type: none"> ● 10...150 kHz: 120...69 dBμV/m QP ● 150...1500 kHz: 79...63 dBμV/m QP ● 1.5...30 MHz: 63 dBμV/m QP 	
Radiated emission	IEC/EN 55011 (IEC/CISPR Publication 11)	Class A, 10 m distance: <ul style="list-style-type: none"> ● 30...230 MHz: 40 dBμV/m QP ● 230 MHz...1 GHz: 47 dBμV/m QP 	
(1) Common mode			
(2) Differential mode			

Certifications and Standards

Introduction

The Remote Graphic Display is designed to conform to the main national and international standards concerning electronic industrial control devices:

- IEC/EN 61131-2
- UL 508C

The Remote Graphic Display has obtained the following conformity marks:

- CE
- UL

Compatibility of The Remote Graphic Display

Overview

Before using the Remote Graphic Display, verify the compatibility of the Remote Graphic Display with the version of EcoStruxure Machine Expert - Basic, the controller firmware version, and the functional level of the application.

Compatibility With EcoStruxure Machine Expert - Basic

The installed version of EcoStruxure Machine Expert - Basic must be equal to or greater than 1.0.

NOTE: To display the installed version of EcoStruxure Machine Expert - Basic, click **About** on the **Start Menu**.

Compatibility with the Controller Firmware

The firmware version of the M221 Logic Controller must be equal to or greater than 1.3.x.y.

NOTE: To display the firmware version, click **Commissioning** → **Connect**, select **M221 Logic Controller**, and click **Login**. Under **Selected Controller**, the firmware version and controller are identified.

You can update the firmware using one of the following methods:

- Controller Updates (*see EcoStruxure Machine Expert - Basic, Operating Guide*) in EcoStruxure Machine Expert - Basic
- ExecLoader (Updating Firmware using Executive Loader Wizard (*see Modicon M221, Logic Controller, Programming Guide*))
- SD card (Firmware Management (*see Modicon M221, Logic Controller, Programming Guide*))

Compatibility with the Functional Level of the Application

The functional level of the application must be equal to or greater than level 3.0.

NOTE: For more information, refer to functional level (*see EcoStruxure Machine Expert - Basic, Operating Guide*).

Incompatibility Detection

If an incompatibility is detected between Remote Graphic Display and the functional level of the application, the following use cases occur:

Logic Controller Firmware Version	Remote Graphic Display Firmware Version	Consequence	System Object Updates
>= V1.4.x.y	<ul style="list-style-type: none"> ● V1.1IE40 for M221 is displayed on TMH2GDB at power-up ● %SW185 = 0100 hex 	<ul style="list-style-type: none"> ● The Remote Graphic Display shows the Incompatible device or incompatible application level screen. ● %SW182 = 4: Remote Graphic Display firmware update required⁽¹⁾ ● %SW183 = 2: Incompatible version of the display⁽¹⁾ 	Update of the Remote Graphic Display firmware is not possible with this Remote Graphic Display firmware version.
>=V1.4.x.y	<ul style="list-style-type: none"> ● V1.3IEx for M221 is displayed on TMH2GDB at power-up ● %SW185 = 0103 hex 	<ul style="list-style-type: none"> ● The Remote Graphic Display shows the Incompatible device or incompatible application level screen. ● %SW182 = 4: Remote Graphic Display firmware update required⁽¹⁾ ● %SW183 = 2: Incompatible version of the display⁽¹⁾ 	Updating the Remote Graphic Display firmware is possible by using an SD card script.

⁽¹⁾ Refer to %SW182 and %SW183 for more details.

Chapter 2

Installation

Introduction

This chapter provides information related to the installation of the Remote Graphic Display.

What Is in This Chapter?

This chapter contains the following topics:

Topic	Page
Installation and Maintenance Requirements	22
Dimensions and Clearances	24
Mounting	26
Connecting the Remote Graphic Display	29
Updating the Firmware	35

Installation and Maintenance Requirements

Before Starting

Read and understand this chapter before beginning the installation of your system.

The use and application of the information contained herein require expertise in the design and programming of automated control systems. Only you, the user, machine builder or integrator, can be aware of all the conditions and factors present during installation and setup, operation, and maintenance of the machine or process, and can therefore determine the automation and associated equipment and the related safeties and interlocks which can be effectively and properly used. When selecting automation and control equipment, and any other related equipment or software, for a particular application, you must also consider any applicable local, regional, or national standards and/or regulations.

Pay particular attention in conforming to any safety information, different electrical requirements, and normative standards that would apply to your machine or process in the use of this equipment.

DANGER

HAZARD OF ELECTRIC SHOCK, EXPLOSION OR ARC FLASH

Replace and secure all covers, accessories, hardware, cables, and wires and confirm that a proper ground connection exists before applying power to the unit.

Failure to follow these instructions will result in death or serious injury.

Programming Considerations

WARNING

UNINTENDED EQUIPMENT OPERATION

- Only use software approved by Schneider Electric for use with this equipment.
- Update your application program every time you change the physical hardware configuration.

Failure to follow these instructions can result in death, serious injury, or equipment damage.

Operating Environment

This equipment has been designed to operate outside of any hazardous location. Only install this equipment in zones known to be free of a hazardous atmosphere.

DANGER

POTENTIAL FOR EXPLOSION

Install and use this equipment in non-hazardous locations only.

Failure to follow these instructions will result in death or serious injury.

WARNING

UNINTENDED EQUIPMENT OPERATION

Install and operate this equipment according to the conditions described in the section Technical Presentation.

Failure to follow these instructions can result in death, serious injury, or equipment damage.

Installation Considerations

WARNING

UNINTENDED EQUIPMENT OPERATION

- Use appropriate safety interlocks where personnel and/or equipment hazards exist.
- Do not use this equipment in safety-critical machine functions unless the equipment is otherwise designated as functional safety equipment and conforming to applicable regulations and standards.
- Do not disassemble, repair, or modify this equipment.
- Do not connect any wiring to reserved, unused connections, or to connections designated as No Connection (N.C.).

Failure to follow these instructions can result in death, serious injury, or equipment damage.

Dimensions and Clearances

Introduction

This section describes the dimensions and the mounting clearances for the Remote Graphic Display.

Dimensions

This illustration describes the external dimensions of the Remote Graphic Display:

$\frac{\text{mm}}{\text{in.}}$

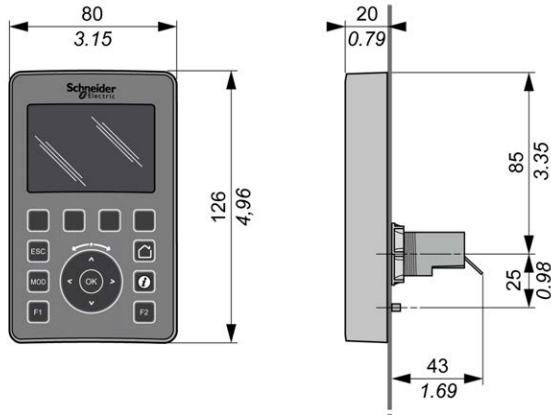

Minimum Clearances

⚠ WARNING

UNINTENDED EQUIPMENT OPERATION

- Place devices dissipating the most heat at the top of the cabinet and ensure adequate ventilation.
- Avoid placing this equipment next to or above devices that might cause overheating.
- Install the equipment in a location providing the minimum clearances from all adjacent structures and equipment as directed in this document.
- Install all equipment in accordance with the specifications in the related documentation.

Failure to follow these instructions can result in death, serious injury, or equipment damage.

The Remote Graphic Display has been designed as an IP65 product when properly installed, excluding the RJ45 connector. The Remote Graphic Display must be installed on the front panel of the cabinet or enclosure to achieve the IP65 rating. Clearances must be respected when installing the product.

There are four types of clearances between:

- The Remote Graphic Display and all sides of the cabinet (including the panel door).
- The Remote Graphic Display connector and the wiring ducts. This distance reduces electromagnetic interference between the Remote Graphic Display and the wiring ducts.
- The Remote Graphic Display and other heat generating devices installed in the same cabinet.
- The Remote Graphic Display and other Remote Graphic Display on the same panel door.

This illustration describes the minimum clearances:

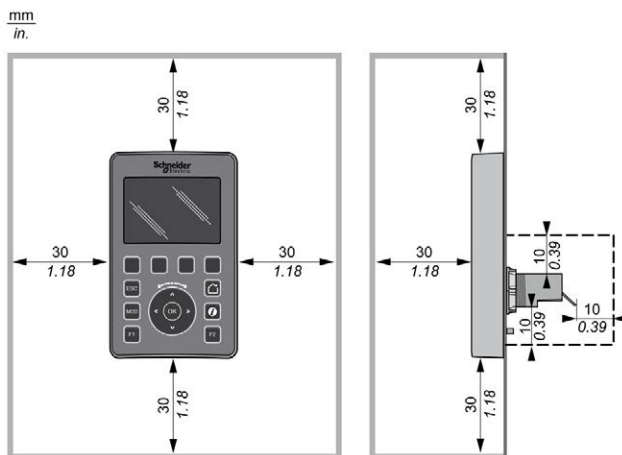

NOTE: Keep adequate spacing for proper ventilation and to maintain the operating temperature specified in the Environmental Characteristics ([see page 16](#)).

Mounting

Overview

This section presents how to install the Remote Graphic Display on the cabinet panel.

Mounting Hole Layout

This diagram presents the drilling template for the Remote Graphic Display:

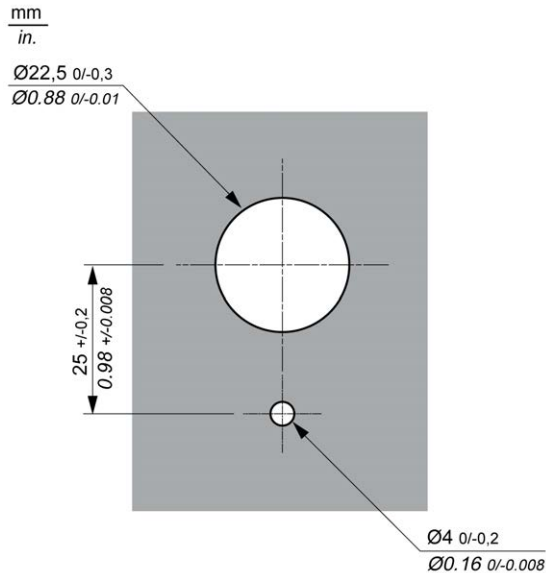

Prerequisites Before Installing the Remote Graphic Display

Before installing the Remote Graphic Display, verify that:

- The gasket must be uniform and undamaged.
- The installation panel or cabinet surface must be flat and smooth, with a tolerance of 0.5 mm (0.019 in).
- The panel thickness must be between 1.5 mm and 6 mm if the cabinet panel is steel sheeting, or between 3 mm and 6 mm if the cabinet panel is glass fiber reinforced plastic.

Installing the Remote Graphic Display

This procedure describes how to install the Remote Graphic Display:

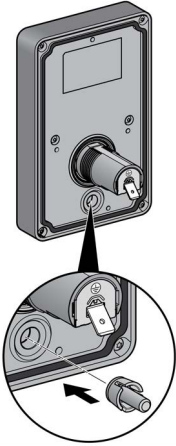
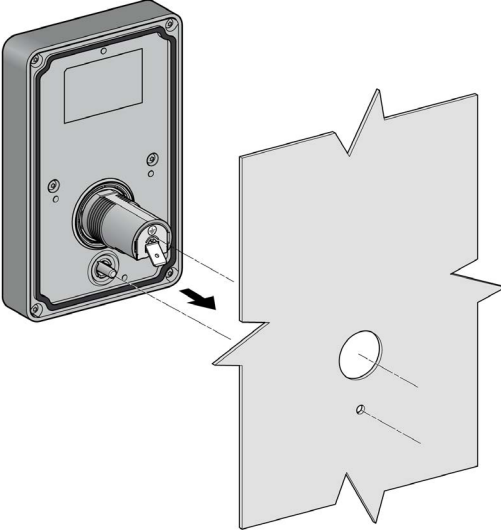
Step	Action
1	<p data-bbox="353 285 916 310">Insert the anti-rotation tee into the Remote Graphic Display.</p>  <p data-bbox="353 813 1215 862">NOTE: The rotating torque that can be supported by the Remote Graphic Display is 6 N.m (53.10 in-lb).</p>
2	<p data-bbox="353 878 883 902">Insert the Remote Graphic Display on the cabinet panel.</p> 

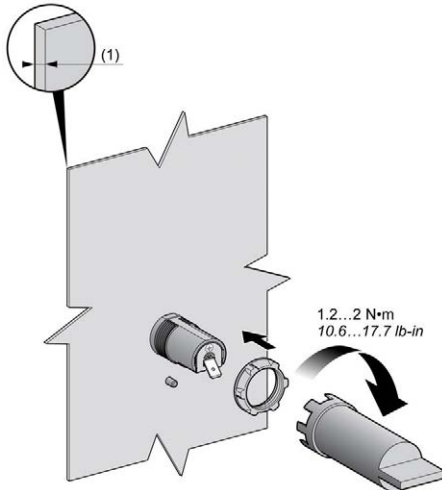
Step	Action
3	<p>Install the nut and tighten it with the socket wrench (ZB5AZ905).</p>  <p>(1) 1,5...6 mm (0.06...0.24 in) if steel sheet or 3...6 mm (0.12...0.24 in) if glass fiber reinforced plastic (minimum GF30)</p>

Cleaning the Remote Graphic Display

When the front panel of the Remote Graphic Display needs cleaning, wipe it with a soft cloth. If necessary, use a neutral detergent.

NOTICE

INOPERABLE EQUIPMENT

Do not use any liquids containing acids, organic solvents, alcohol, or abrasive materials to clean the unit.

Failure to follow these instructions can result in equipment damage.

Care must be taken when wiping the surface of the Remote Graphic Display. Inadvertently pressing the keys while doing so may unintendedly engage programmed machine operations.

⚠ WARNING

UNINTENDED EQUIPMENT OPERATION

Do not press any of the keys while cleaning the surface of the equipment.

Failure to follow these instructions can result in death, serious injury, or equipment damage.

Connecting the Remote Graphic Display

Overview

The Remote Graphic Display must be connected only to the **Serial** or **Serial 1** port of the logic controller. These serial ports of the logic controllers provide the 5 Vdc power supply of the Remote Graphic Display. The Remote Graphic Display must be the only device connected to these serial ports (do not use a Tap-off box). The connection between the Remote Graphic Display and the logic controller is RS-485 (Modbus protocol).

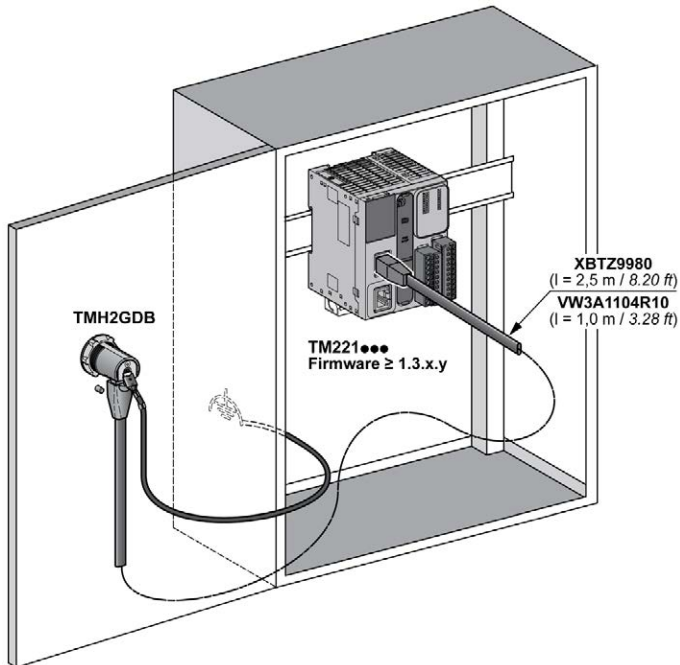

Logic Controller Connection

The following graphics present the location of the **Serial** or **Serial 1** port, depending on the logic controller reference:

TM221C●●R
TM221C●●T

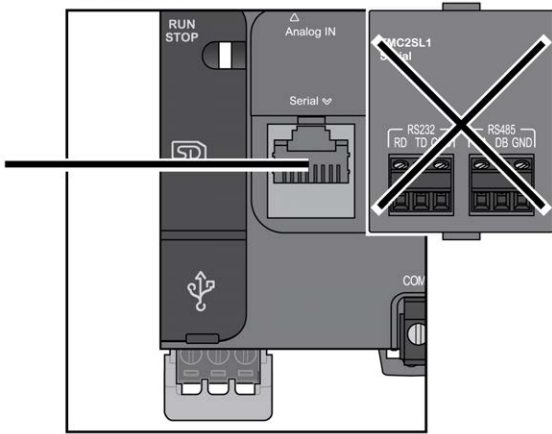

TM221CE●●R
TM221CE●●T

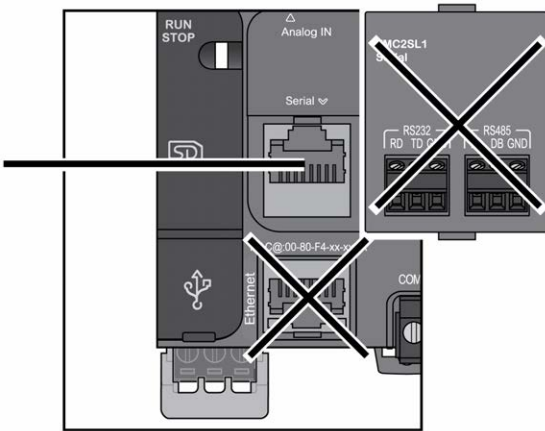

TM221M16●/G
TM221M32TK

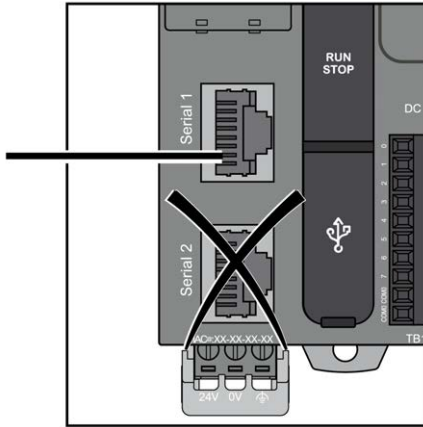

TM221ME16●/G
TM221ME32TK

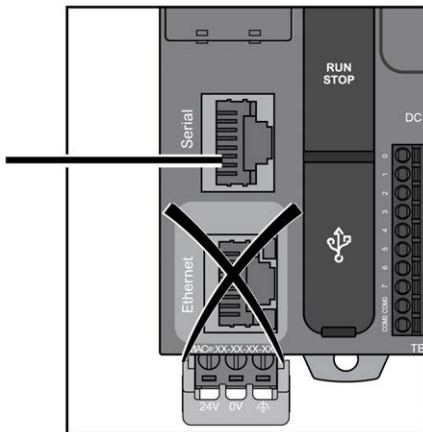

Pin Assignment

This illustration presents the pin assignment of the RJ45 connector:

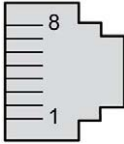

Pin	Signal	Description
1	N.C.	No connection
2	N.C.	No connection
3	N.C.	No connection
4	D1	Modbus SL: D1 (+/B) RS-485 2-wire
5	D0	Modbus SL: D0 (-/A) RS-485 2-wire
6	N.C.	No connection
7	5 Vdc	Power delivered by the logic controller
8	0 Vdc	-

⚠ WARNING

UNINTENDED EQUIPMENT OPERATION

Do not connect wires to unused terminals and/or terminals indicated as “No Connection (N.C.)”.

Failure to follow these instructions can result in death, serious injury, or equipment damage.

Grounding

The grounding lug of the Remote Graphic Display must be connected to the ground terminal screw of the cabinet.

This table presents the characteristics of the grounding connection:

Characteristic	Description
Minimum wire gauge	2.5 mm ² (AWG 14)
Lug size	6.35 x 0.81 mm (0.25 x 0.032 in)
Connection	Female spade terminal (AMP 6392-1 or similar)

Connecting Cables

You can use the following cable for connecting the Remote Graphic Display to the logic controller:

Reference	Description	Length
XBTZ9980	Modbus serial link cable (2 RJ45 male connectors)	2.5 m (8.20 ft)
VW3A1104R10	Modbus serial link cable (2 RJ45 male connectors)	1.0 m (3.28 ft)

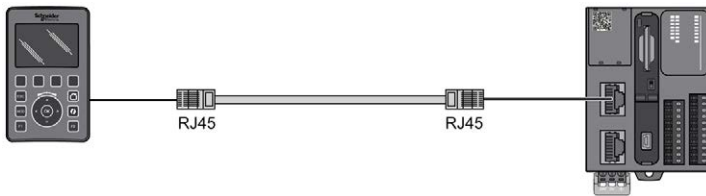

This illustration presents the internal wiring of the RJ45 connection:

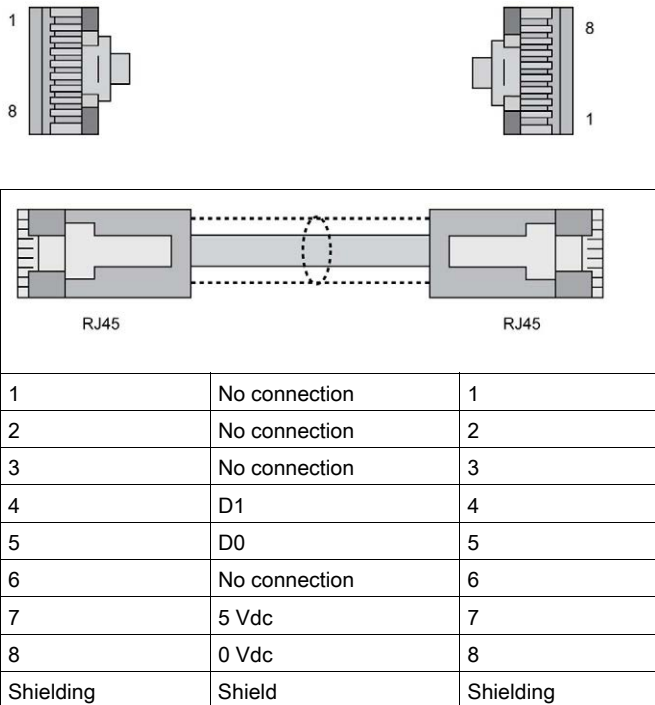

 **WARNING**

UNINTENDED EQUIPMENT OPERATION

Do not connect wires to unused terminals and/or terminals indicated as “No Connection (N.C.)”.

Failure to follow these instructions can result in death, serious injury, or equipment damage.

Updating the Firmware

Presentation

Firmware updates can be downloaded to the Remote Graphic Display from the PC that is running EcoStruxure Machine Expert - Basic.

For details, refer to Downloading Firmware to the Remote Graphic Display (*see Modicon M221, Logic Controller, Programming Guide*).

Chapter 3

How to Use the Remote Graphic Display

Introduction

This chapter provides information related to the graphic screen presentations, the navigation, and the password protection of the Remote Graphic Display.

What Is in This Chapter?

This chapter contains the following topics:

Topic	Page
Description	38
Navigation	39
Password Protection	41

Description

Graphic Screen Description

This is a graphic screen example of the Remote Graphic Display:

Alarm	Setup Menu	01/01/2012 00:45:29	1
Controller Info			
Controller Setup			2
Display Setup			
Controller State			
Controller Status			
Select	Alarm		3
		Back	

This table describes the areas of the graphic screen:

Item	Name	Label	Description
1	Header	Alarm	<p>Informs you that at least 1 alarm is active on the Alarm View page (see page 49).</p> <p>NOTE: This field is empty if no alarm is active or if no Alarm View (see page 77) page has been defined.</p>
		Page title	–
		Date and time	–
2	Menus or Pages	–	Menus, submenus, parameters, values, or other content are displayed in scrolling window format on five displayed lines.
3	Footer	R1 to R4	Labels corresponding to actions if configured at a page level. For more information, refer to Actions (see page 75).

Home Page

After connecting the Remote Graphic Display, it displays the home page that has been chosen in EcoStruxure Machine Expert - Basic ([see page 55](#)).

The default home page is the **Setup Menu** that allows you to configure and monitor the general parameters of your logic controller ([see page 43](#)).

Navigation

Overview

This table describes the navigation controls of the Remote Graphic Display:

Name	Function	Comment
F1 key	Executes actions defined with EcoStruxure Machine Expert - Basic for that key.	For more information, refer to Actions (see page 75).
MOD key	Moves to the next selectable object.	In a page with a scroll bar, this key is disabled.
ESC key	Goes back to the previous page.	You can go back up to 12 pages.
R1 to R4 keys	Execute an action.	The actions are either fixed, such as those found in Setup pages, or defined/assigned with EcoStruxure Machine Expert - Basic for Operator Interface pages. For more information, refer to Actions (see page 75).
Home key	Goes back to the Home page.	For more information, refer to Home Page (see page 38).
Information key	Displays a contextual help page.	The help pages are either fixed, such as those found in Setup pages, or defined/assigned with EcoStruxure Machine Expert - Basic for Operator Interface pages. For more information on help pages, refer to the Template Pages (see page 62).
F2 key	Executes actions defined with EcoStruxure Machine Expert - Basic for that key.	For more information, refer to Actions (see page 75).
Touch wheel Up/down arrows	Depending on the page, it can either: <ul style="list-style-type: none"> ● Select the next/previous elements displayed ● Increment/decrement the selected object 	–
Right/left arrows	Select the next/previous selectable object.	In a page with a scroll bar, right/left arrows are disabled.
OK	<ul style="list-style-type: none"> ● Opens a menu, submenu, or page. ● Enables modification for the numerical value of a parameter. 	For more information, refer to Edit Pages (see page 46).

NOTICE

INOPERABLE EQUIPMENT

Do not use hard or pointed objects to operate the device.

Failure to follow these instructions can result in equipment damage.

Access Protection

The access to some pages can be restricted by a password. For more information, refer to Password Protection (*see page 41*).

Password Protection

Overview

You can use EcoStruxure Machine Expert - Basic software to define a password. If enabled, this unique password helps to protect:

- the selected page(s) of the **Operator Interface**
- The **Setup** pages that can perform an action on the logic controller:
 - **Controller Setup**
 - **Controller State**
 - **Data Table**
 - **Alarm Reset**

For more information, refer to Set General Parameters (*see page 60*).

Password Management in the Remote Graphic Display

When you try to access a protected page on the Remote Graphic Display, you need to enter the password:

If...	Then ...	Comment
The entered password is correct	You can consult the pages.	The password is valid for 10 minutes or until you press the Home key.
The entered password is incorrect	An error message appears.	When leaving the error page, you can enter the password again. If you cancel, the Home page is displayed.

Chapter 4

Setup Menu Functionality

Introduction

This chapter provides information related to the menus present in the **Setup** of the Remote Graphic Display.

What Is in This Chapter?

This chapter contains the following topics:

Topic	Page
Setup Menu Presentation	44
Controller Setup Menu	45
Controller State Menu	47
Alarm Menu	49
Data Table Menu	51

Setup Menu Presentation

Menu Structure

This table lists the menu and submenus present in the **Setup Menu** of the Remote Graphic Display:

Menu	Submenu	Comment
Controller Information	Device Name Firmware Version Last MAST cycle Min. MAST cycle Max. MAST cycle	–
Controller Setup	Date and Time Serial 2 Ethernet	For more information, refer to the Controller Setup Menu (<i>see page 45</i>).
Display Setup	Language Contrast Backlight timeout	The language, the contrast and backlight timeout values are saved inside the Remote Graphic Display. The default backlight timeout is 10 minutes, it can be set from 0 (no timeout) to 10 minutes maximum.
Controller State	–	For more information, refer to the Controller State Menu (<i>see page 47</i>).
Controller Status	Application Boot App IO Bus Cartridge	Each status can have these values: <ul style="list-style-type: none"> • OK • Not OK
Alarm Menu	View History Delete History	For more information, refer to the Alarm Menu (<i>see page 49</i>).
Data Table	–	For more information, refer to the Data Table Menu (<i>see page 51</i>).
SD Card Information	–	It is a help page that explains how to transfer firmware, application, and post configuration from: <ul style="list-style-type: none"> • The logic controller to the SD card • The SD card to the logic controller

NOTE: Keeping the backlight ON continuously reduces the lifetime of the device.

NOTICE

INOPERABLE EQUIPMENT

Set the Backlight timeout of the device between 1 and 10 minutes.

Failure to follow these instructions can result in equipment damage.

Controller Setup Menu

Overview

This table lists the submenus that are present in the **Controller Setup** menu of the **Setup**:

Submenu	Function	Comment
Date and Time	Allows you to set the logic controller internal date and time.	The format of date and time can only be configured in EcoStruxure Machine Expert - Basic. Refer to Set the General Parameters (<i>see page 60</i>).
Serial 2 (depending on the logic controller reference)	Allows you to configure the Serial 2 parameters ⁽¹⁾ : <ul style="list-style-type: none"> ● Physical Medium ● Baud rate ● Parity ● Format ● Stop Bits ● Modbus Address ● Polarization 	Serial 1 cannot be configured as it interrupts the ongoing communication with the Remote Graphic Display.
Ethernet (depending on the logic controller reference)	Allows you to configure the Ethernet parameter ⁽¹⁾ : <ul style="list-style-type: none"> ● IP Mode ● IP Address ● Mask ● Gateway ● Device Name 	If the IP Address and Mask are incorrect, your logic controller is automatically configured with the default values.
(1) The entered parameters are saved into the Post Configuration file. The parameters are retained after a power cycle.		

NOTE: For more information on how to modify the **Serial 2** or **Ethernet** parameters, refer to Edit Pages (*see page 46*).

Edit Pages

This graphic presents the **Edit IP** page:

Alarm	Edit IP	23/03/2015 11:00:00
<p>IP Address</p> <p>10 . 10 . 255 . 51</p>		
Valid		Cancel

This procedure explains how to modify selected parameters in the **Serial 2** and **Ethernet** submenus:

Step	Action
1	Select Setup → Controller Setup .
2	Select Serial 2 or Ethernet . Result: The Serial 2 or Ethernet page is displayed.
3	Select the parameter with the touch wheel and press OK to modify it. Result: One of these pages is displayed: <ul style="list-style-type: none"> ● Edit Parameter ● Edit IP ● Edit Name
4	Select the digit using the MOD key or right/left arrows.
5	Increment or decrement the selected digit using the touch wheel or up/down arrows. Turn the touch wheel in the same direction for more than 2 seconds to accelerate the scrolling of digits.
6	Press: <ul style="list-style-type: none"> ● R1 (Valid) to apply the modification. ● R4 (Cancel) to discard the modification. <p>NOTE: Press the ESC key to discard the modification and go back to the previous page.</p>

Controller State Menu

Overview

The **Controller State** menu allows you to see the present state of your logic controller and perform commands in the logic controller.

Remote Control Considerations

Care must be taken and provisions made for use of this product as a control device to avoid inadvertent consequences of commanded machine operation, state changes, or alteration of data memory or machine operating parameters.

WARNING

UNINTENDED EQUIPMENT OPERATION

- Place operator devices of the control system near the machine or in a place where you have full view of the machine.
- Protect operator commands against unauthorized access.
- If remote control is a necessary design aspect of the application, ensure that there is a local, competent, and qualified observer present when operating from a remote location.
- Configure and install the Run/Stop input, if so equipped, or, other external means within the application, so that local control over the starting or stopping of the device can be maintained regardless of the remote commands sent to it.

Failure to follow these instructions can result in death, serious injury, or equipment damage.

WARNING

UNINTENDED MACHINE OR PROCESS START-UP

- Verify the state of security of your machine or process environment before applying power to the Run/Stop input.
- Use the Run/Stop input to help prevent the unintentional start-up from a remote location.

Failure to follow these instructions can result in death, serious injury, or equipment damage.

Logic Controller Commands

This procedure explains how to perform the logic controller commands:

Step	Action
1	Select Setup → Controller State .
2	Press: <ul style="list-style-type: none">● R1 (Run) to start the logic controller● R2 (Stop) to stop the logic controller● R3 (Init) to initialize the logic controller
3	When a confirmation page is displayed, select Yes or No .
4	Press: <ul style="list-style-type: none">● R1 (Valid)● R4 (Cancel)

For more information, refer to the Controller States and Behaviors part of your logic controller programming guide.

Alarm Menu

Overview

The **Alarm Menu** contains these submenus:

- **View**
- **History**
- **Delete History**

Alarm View

The **Alarm View** page displays the active alarms. Alarm messages are configured in EcoStruxure Machine Expert - Basic. For more information, refer to the alarm definition (*see page 77*).

Alarms are associated with specific memory bits within the logic controller. Those bits are monitored and, when **TRUE**, are included in the **Alarm View**.

When system bit %S122 is set to 1, the **Alarm View** page is displayed automatically when a rising edge is detected on an alarm bit.

When system bit %S123 is set to 1, the backlight on the Remote Graphic Display turns red when an alarm is active. For more information, refer to system bit (%S122 and %S123) description (*see Modicon M221, Logic Controller, Programming Guide*).

NOTE: Alarm bit must be ON for at least 50 ms before it is included in the **Alarm View**.

NOTE: Alarms are not saved when the controller goes through a power cycle.

Alarm History

Alarm History		09/03/2015 10:01:11
Power is OFF	▼	09/03/2015 09:54:24
Power is OFF	▲	09/03/2015 09:54:22
Machine door open	▼	09/03/2015 09:54:19
Machine door open	▲	09/03/2015 09:54:15
Alarm	Delete	Back

The **History** page displays a maximum of 40 alarm messages with the date and time when the alarm either became active or was resolved, along with an up arrow to indicate when the alarm became active and a down arrow when it is resolved. The most recent alarm is at the top of the list.

Alarm Reset

The **Alarm Reset** page is used to clear the alarm history:

Step	Action
1	Select Setup → Alarm Menu → Delete History . Result: The Alarm Reset page is opened.
2	Press R1 (Delete) to clear the alarm history. Result: The Alarm History page is empty.

Data Table Menu

Overview

In the **Data Table** page, you can add/delete or modify the value of a variable:

- Memory objects
- System objects
- I/O objects

A maximum of 20 entries is displayed in this page.

NOTE: This table is not saved after a power cycle of your logic controller.

Remote Control Considerations

Care must be taken and provisions made for use of this product as a control device to avoid inadvertent consequences of commanded machine operation, state changes, or alteration of data memory or machine operating parameters.

WARNING

UNINTENDED EQUIPMENT OPERATION

- Place operator devices of the control system near the machine or in a place where you have full view of the machine.
- Protect operator commands against unauthorized access.
- If remote control is a necessary design aspect of the application, ensure that there is a local, competent, and qualified observer present when operating from a remote location.
- Configure and install the Run/Stop input, if so equipped, or, other external means within the application, so that local control over the starting or stopping of the device can be maintained regardless of the remote commands sent to it.

Failure to follow these instructions can result in death, serious injury, or equipment damage.

Object Types

These memory objects are available:

- System bit (%S)
- System word (%SW)
- Memory bit (%M)
- Memory word (%MW)
- Constant word (%KW)
- Memory double word (%MD)

These I/O objects are available:

- Input bit (%I)
- Output bit (%Q)
- Input word (%IW)
- Output word (%QW)
- Input status word (%IWS)
- Output status word (%QWS)

Add/Delete a Variable

This procedure explains how to add a variable in the **Data Table** page:

Step	Action
1	Select Setup → Data Table .
2	Press R1 (Add) . Result: The Object Type page is displayed.
3	Select the object types. For more information on object types, refer to the list (<i>see page 52</i>).
4	Press R1 (Select) .
5	Enter: <ul style="list-style-type: none"> ● The address for a memory object. ● The module and channel values for an I/O object.
6	Press R3 (Edit) or use the touch wheel.
7	Select the displayed representation (Decimal or hexadecimal).
8	Press R1 (Add) to add the variable in the data table.
9	Repeat steps 2 to 8 to add another variable to your monitoring list.

NOTE: You can delete a variable from the table by pressing **R2 (Delete)**.

Edit a Variable

You can modify the value of an existing variable.

NOTE: Editing a variable is not allowed when the logic controller state is `EMPTY`.

Follow the procedures below when editing:

- A word or double word variable
- A memory bit variable
- An I/O bit variable

Edit a Word or a Double Word Variable

This procedure explains how to modify the value of a word or a double word variable in the **Data Table** page:

Step	Action
1	Select Setup → Data Table .
2	Select the word or double word variable to modify.
3	Press R3 (Edit) to modify the variable. Result: The Edit Word or Edit DWord page is displayed.
4	Select the digit using the MOD key or right/left arrows.
5	Increment or decrement the selected digit using the touch wheel or up/down arrows.
6	Press: <ul style="list-style-type: none"> • R1 (Apply) to apply the modification. • R4 (Cancel) to discard the modification. NOTE: Press the ESC key to discard the modification and go back to the previous page.
7	Repeat steps 2 to 6 to modify another word or double word variable.

Edit a Memory Bit Variable

This procedure explains how to modify the value of a memory bit variable in the **Data Table** page:

Step	Action
1	Select Setup → Data Table .
2	Select the memory bit variable to modify.
3	Press R3 (Edit) to modify the variable. Result: The Edit bit page is displayed.
4	Select Off or On using the touch wheel or up/down arrows.
5	Press: <ul style="list-style-type: none"> • R1 (Apply) to apply the modification. • R4 (Cancel) to discard the modification. NOTE: Press the ESC key to discard the modification and go back to the previous page.
6	Repeat steps 2 to 5 to modify another memory bit variable.

Edit an I/O Bit Variable

Forcing input and output values in a running logic controller can have serious consequences to the operation of a machine or process. Only those who understand the implications in the controlling logic, and who understand the consequences of forced I/O on the machine or process, should attempt to use this function.

WARNING

UNINTENDED EQUIPMENT OPERATION

You must have prior knowledge of the process and the controlled equipment before attempting to force logic controller physical inputs/outputs, or writing values to logic controller memory locations.

Failure to follow these instructions can result in death, serious injury, or equipment damage.

This procedure explains how to modify the value of an I/O bit variable in the **Data Table** page:

Step	Action
1	Select Setup → Data Table .
2	Select the I/O bit variable to modify.
3	Press R3 (Edit) to modify the variable. Result: The Edit I/O bit page is displayed.
4	Select Off or On using the touch wheel or up/down arrows.
5	Press: <ul style="list-style-type: none"> ● R1 (Apply) to apply the modification. ● R2 (Force) to force the I/O value. ● R3 (Unforce) to unforce the I/O value. ● R4 (Cancel) to discard the modification. <p>NOTE: Press the ESC key to discard the modification and go back to the previous page.</p>
6	Repeat steps 2 to 5 to modify another I/O bit variable.

Chapter 5

Creating an Operator Interface with EcoStruxure Machine Expert - Basic

Introduction

This chapter provides information on how to build an **Operator Interface** in the **Display** tab of EcoStruxure Machine Expert - Basic.

What Is in This Chapter?

This chapter contains the following topics:

Topic	Page
Prerequisite	56
EcoStruxure Machine Expert - Basic Display Tab	58
General Properties	60
Add/Delete a Page	62
Configure a Page	71
Export/Import a Page	74
Actions	75
Alarm Definition	77

Prerequisite

Serial Line Configuration

To configure the **Serial/Serial 1** line in EcoStruxure Machine Expert - Basic:

Step	Action
1	Select the Configuration tab.
2	Click the SL1 (Serial Line) node in the hardware tree.
3	<p>Select TMH2GDB in the Protocol field. The Remote Graphic Display uses fixed serial line communication parameters:</p> <div data-bbox="326 492 1108 1015" style="border: 1px solid gray; padding: 10px;"> <p>Serial line configuration</p> <p>Protocol Settings</p> <p>Protocol TMH2GDB ▾</p> <hr/> <p>Serial line settings</p> <p>Baud rate 19200</p> <p>Parity Even</p> <p>Data bits 8</p> <p>Stop bits 1</p> <p>Physical medium</p> <p><input checked="" type="radio"/> RS-485 Polarization No</p> <p><input type="radio"/> RS-232</p> <p style="text-align: right;">Apply Cancel</p> </div>
4	<p>Click Apply.</p> <p>Result: The serial line is configured to communicate with your Remote Graphic Display and the Display tab is activated.</p>
5	Click the Display node that appears below the SL1 (Serial Line) node in the hardware tree to display device settings.

This graphic presents the **Device settings** in the **Configuration** tab of EcoStruxure Machine Expert - Basic:

Device settings

Device

Protocol Settings

Transmission mode RTU ASCII

Addressing Slave Master Address [1...247]

Response timeout (x 100 ms)

Time between frames (ms)

EcoStruxure Machine Expert - Basic Display Tab

Overview

The **Operator Interface** is a component of the application.

- For more information on creating projects, refer to Creating Projects With EcoStruxure Machine Expert - Basic (see *EcoStruxure Machine Expert - Basic, Operating Guide*).
- For more information on transferring applications, refer to Downloading and Uploading Applications (see *EcoStruxure Machine Expert - Basic, Operating Guide*).



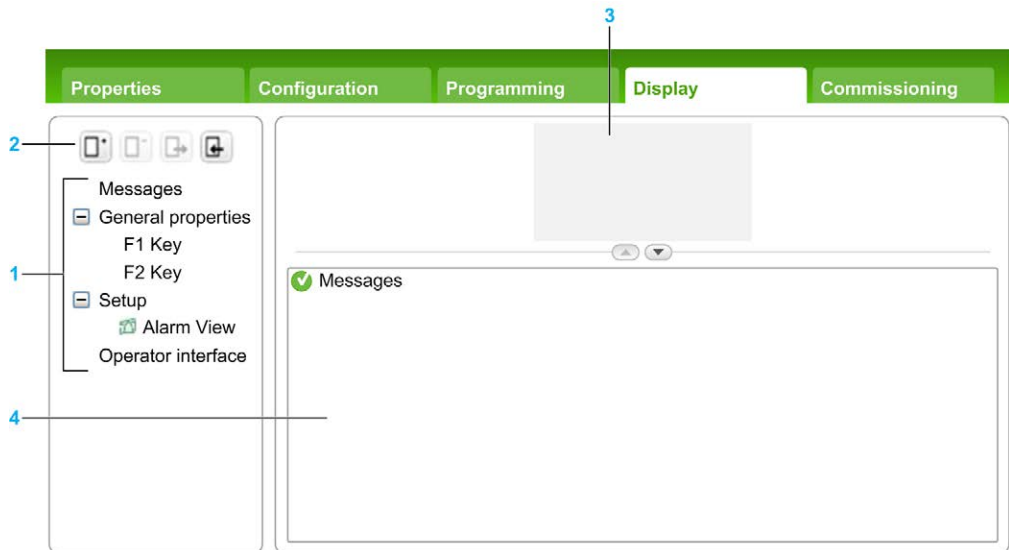

The **Operator Interface** is built with the **Display** tab in EcoStruxure Machine Expert - Basic:



- 1 Tree
- 2 Buttons
- 3 Visualization area
- 4 Editable area

Button Description

The buttons apply to the pages of the **Operator Interface**:

Button	Menu	Function
	AddPage	Add a page (<i>see page 62</i>).
	DeletePage	Delete a customized page (<i>see page 70</i>).
	ExportPage	Export a page (<i>see page 74</i>).
	ImportPage	Import a page (<i>see page 74</i>).

Tree Description

This table lists the menus and submenus present in the tree in the **Display** tab:

Menu	Submenu	Comment
Messages	–	If there is an error detected, a message is displayed.
General Properties	F1 Key F2 Key	To set the general parameters (<i>see page 60</i>).
Setup	Alarm View	To define a set of alarms (<i>see page 77</i>).
Operator Interface	–	To create customized menus, submenus and pages with the predefined templates (<i>see page 62</i>).

General Properties

Overview

The **General Properties** node allows you to set the general parameters of the Remote Graphic Display.

General properties

Date format dd/mm/yyyy ▾

Time format 24 hh/mm/ss ▾

Password 6037

Password protect Setup

Home page Setup menu (112) ▾

You may select time and date formats, the home page for the Operator Interface that you have defined, and the password used for the Remote Graphic Display. The password is effective in helping to protect the Operator pages that you have selected to be protected, and, if you choose, the Setup pages that affect the logic controller state and data.

NOTE: The page defined as the home page cannot be protected by password. Setting a page protected by password as the home page automatically removes its password protection. A password, randomly selected, is automatically assigned as a default every time you create a new application. In addition, the **Password protect Setup** option is selected by default.

Set General Properties

This procedure explains how to set the general properties of the **Display** tab:

Step	Action	Comments
1	Select the General Properties node in the tree.	–
2	Select the date format in the Date format field.	The date and time formats are used in the standard header and in the alarm history.
3	Select the time format in the Time format field.	
4	Enter a password to protect the selected Operator Interface pages and, optionally, the Setup .	NOTE: You may change the default password, or unselect the optional Setup protection.
5	Activate the Password protect Setup check box to use the password to protect the Setup .	For more information, refer to Password Protection (see page 41).
6	Select the home page. The home page is the first page displayed once your application has been downloaded into the controller and also when you press the Home button on the Remote Graphic Display.	The Setup menu page is selected by default. Any other operator interface pages you have created can also be selected. For more information, refer to Add a page (see page 62).

F1 and F2 Key Assignments

This procedure explains how to assign actions to **F1 Key** and **F2 Key**:

Step	Action
1	Select the F1 Key or F2 Key node in the tree.
2	Select the Action type that you want to associate with the key. For more information, refer to Action (<i>see page 75</i>).

Add/Delete a Page

Overview

To build your **Operator Interface**, you need to create pages in the **Display** tab by using templates.

Add a Page

This table explains how to add a page in the **Operator Interface**:

Step	Action
1	 <p>Click the AddPage button. Result: The Select a page template window is displayed.</p>
2	<p>Select the template page:</p> <ul style="list-style-type: none"> ● Menu template (<i>see page 63</i>) ● Monitor template (<i>see page 64</i>) ● Control table template (<i>see page 65</i>) ● Bargraph template (<i>see page 66</i>) ● Double bargraph template (<i>see page 67</i>) ● VU meter template (<i>see page 68</i>) ● Toggle control table template (<i>see page 69</i>)
3	<p>Click OK to validate. Result: The page is added in the tree (<i>see page 59</i>).</p>
4	<p>Configure the properties of the page as described in Configure a page (<i>see page 71</i>).</p>
5	<p>Repeat steps 1 to 3 to add another page in your Operator Interface.</p>

Menu Template

A menu page allows the user to navigate between several pages.

The user can press Select (**R1**) button to display the selected page.

To configure a menu page:

Step	Action
1	Select the Elements node in the tree.
2	Enter the text to display.
3	Select a Destination page .
4	Click Add .
5	Repeat steps 2 to 4 to configure other destination pages. You can add a maximum of 30 elements to the page.
6	Configure the R2, R3, and R4 Key assignments (<i>see page 73</i>).

TMH2GDB example:

	MENU	14/09/2015 03:57:47
FILTERING TIME SHOCK TREATMENT PRESSURE VISU.		
Select	Alarm	R3 R4

Elements node in EcoStruxure Machine Expert - Basic example:

Text	Destination page
FILTERING TIME	FILTER
SHOCK TREATMENT	MAINTEN
PRESSURE VISU.	Controller Info

Monitor Template

A monitor page allows the user to monitor memory or I/O variables.

If the **Write access** is activated, the user can press Edit (**R1**) button to modify the selected variable value.

To configure the monitor page:

Step	Action
1	Select the Elements node in the tree.
2	Enter the text to display.
3	Enter the variable to monitor. Refer to the available variable type (<i>see page 72</i>) or refer to the text that is displayed when the pointer is on Variable .
4	Click Add .
5	On the created line, activate the Write access check box to allow the user to modify the variable value.
6	Repeat steps 2 to 5 to configure other variables to monitor. You can add a maximum of 30 elements to the page.
7	Configure the R2, R3, and R4 Key assignments (<i>see page 73</i>).

TMH2GDB view:

	TEMPERATURE	14/09/2015 23:45:22
ENTRY		19
CORRIDOR		18
MEETING ROOM 1		20
MEETING ROOM 2		16
LOCKER ROOM		22
Edit	Alarm	+20°C +17°C

Elements node in EcoStruxure Machine Expert - Basic example:

	Text	Variable:	Write access
▶	ENTRY	%MW0	<input checked="" type="checkbox"/>
	CORRIDOR	%MW1	<input checked="" type="checkbox"/>
	MEETING ROOM 1	%MW2	<input checked="" type="checkbox"/>
	MEETING ROOM 2	%MW3	<input checked="" type="checkbox"/>
	LOCKER ROOM	%MW4	<input checked="" type="checkbox"/>

Control Table Template

A control page allows the user to control memory or I/O bit values.

This page allows you to associate a text string to each bit value.

If the **Write access** is activated, the user can press On (**R1**) or Off (**R2**) buttons to change the selected bit value.

To configure the control page:

Step	Action
1	Select the Elements node in the tree.
2	Enter the variable to control. Refer to the available variable type (<i>see page 72</i>) or refer to the text that is displayed when the pointer is on Variable .
3	Enter the Text when value is TRUE .
4	Enter the Text when value is FALSE .
5	Click Add .
6	On the created line, activate the Write access check box to allow the user to modify the variable value.
7	Repeat steps 2 to 6 to configure other variables to monitor. You can add a maximum of 30 elements to the page.
8	Configure the R3 and R4 Key assignments (<i>see page 73</i>).

TMH2GDB view:

GATE CONTROL		14/09/2015 23:23:58	
DOOR OPEN			
LIGHT OFF			
BARRING			
On	Off	LIGHT	Alarm

Elements node in EcoStruxure Machine Expert - Basic example:

Variable:	Text when value is TRUE	Text when value is FALSE	Write access
%M0	DOOR OPEN	DOOR CLOSED	<input checked="" type="checkbox"/>
%M1	LIGHT ON	LIGHT OFF	<input checked="" type="checkbox"/>
%M2	BARRING		<input checked="" type="checkbox"/>
%M3	OVERCAPACITY		<input checked="" type="checkbox"/>

Bargraph Template

A bargraph page allows the user to control a memory or I/O variable value with a bargraph representation of the variable value.

If the **Write access** is activated, the user can press Edit (**R1**) button to change the value.

To configure the bargraph page:

Step	Action
1	Select the Elements node in the tree.
2	Enter the variable to control. Refer to the available variable type (<i>see page 72</i>) or refer to the text that is displayed when the pointer is on Variable .
3	Enter the Unit .
4	Enter the Minimum scale value.
5	Enter the Maximum scale value.
6	Activate the Write access check box to allow the user to modify the variable value.
7	Configure the R2, R3, and R4 Key assignments (<i>see page 73</i>).

TMH2GDB view:

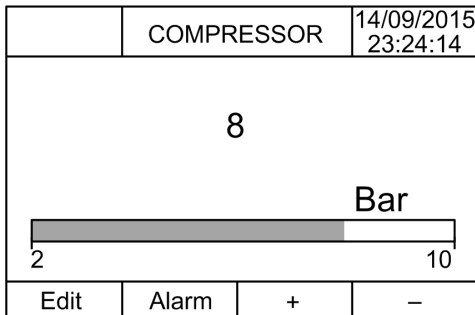

Elements node in EcoStruxure Machine Expert - Basic example:

Elements

Variable

Unit

Minimum

Maximum

Write access

Double Bargraph Template

A double bargraph page allows the user to control 2 memory or I/O variables value with a bar graph representation for each variable value.

If the **Write access** is activated, the user can edit the BarGraph1 variable with the Edit.1 (**R1**) button and the BarGraph2 variable with Edit.2 (**R2**)

To configure the double bargraph page:

Step	Action
1	Select the Elements node in the tree.
2	Enter the variable to control. Refer to the available variable type (<i>see page 72</i>) or refer to the text that is displayed when the pointer is on Variable .
3	Enter the Unit .
4	Enter the Minimum scale value.
5	Enter the Maximum scale value.
6	Activate the Write access check box to allow the user to modify the variable value.
7	Repeat steps 2 to 6 to configure the second variable. You can add a maximum of 30 elements to the page.
8	Configure the R3 and R4 Key assignments (<i>see page 73</i>).

TMH2GDB view:

	WATER SUPPLY	14/09/2015 23:26:13
3		m
0		10
9		m3
0		10
Edit1	Edit2	Alarm Home

Elements node in EcoStruxure Machine Expert - Basic example:

Elements	
Bargraph 1	
Variable	<input type="text" value="%MW6"/>
Unit	<input type="text" value="m"/>
Minimum	<input type="text" value="0"/>
Maximum	<input type="text" value="10"/>
Write access	<input checked="" type="checkbox"/>
Bargraph 2	
Variable	<input type="text" value="%MW7"/>
Unit	<input type="text" value="m3"/>
Minimum	<input type="text" value="0"/>
Maximum	<input type="text" value="10"/>
Write access	<input checked="" type="checkbox"/>

VU Meter Template

A VU meter page allows the user to control a memory or I/O variable value with a VU meter representation of the variable value.

If the **Write access** is activated, the user can press Edit (**R1**) button to change the value.

To configure the VU meter page:

Step	Action
1	Select the Elements node in the tree.
2	Enter the variable to control. Refer to the available variable type (<i>see page 72</i>) or refer to the text that is displayed when the pointer is on Variable .
3	Enter the Unit .
4	Enter the Minimum scale value.
5	Enter the Maximum scale value.
6	Activate the Write access check box to allow the user to modify the variable value.
7	Configure the R2, R3, and R4 Key assignments (<i>see page 73</i>).

TMH2GDB view:

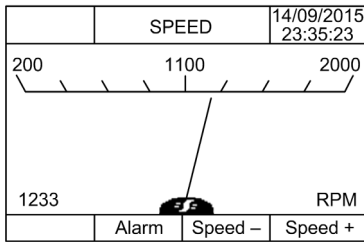

Elements node in EcoStruxure Machine Expert - Basic example:

Elements	
Variable	<input type="text" value="%MW8"/>
Unit	<input type="text" value="RPM"/>
Minimum	<input type="text" value="200"/>
Maximum	<input type="text" value="2000"/>
Write access	<input checked="" type="checkbox"/>

Toggle Control Table Template

A toggle control page allows the user to control memory or I/O bit value.

This page allows you to associate a text string to each bit value.

If the **Write access** is activated, the user can press Not (**R1**) button to toggle the selected bit (TRUE to FALSE or FALSE to TRUE).

To configure the toggle control page:

Step	Action
1	Select the Elements node in the tree.
2	Enter the variable to control. Refer to the available variable type (<i>see page 72</i>) or refer to the text that is displayed when the pointer is on Variable .
3	Enter the Text when value is TRUE .
4	Enter the Text when value is FALSE .
5	Click Add .
6	On the created line, activate the Write access check box to allow the user to modify the variable value.
7	Repeat steps 2 to 6 to configure other variables to control. You can add a maximum of 30 elements to the page.
8	Configure the R2, R3, and R4 Key assignments (<i>see page 73</i>).

TMH2GDB view:

	CRANE CONTROL	14/09/2015 23:35:37	
UP			
LEFT			
POWER OFF			
Not	Light	Power	Alarm

Elements node in EcoStruxure Machine Expert - Basic example:

	Variable:	Text when value is TRUE	Text when value is FALSE	Write access
▶	%Q0.5	UP		<input checked="" type="checkbox"/>
	%Q0.6	DOWN		<input checked="" type="checkbox"/>
	%Q0.7	LEFT		<input checked="" type="checkbox"/>
	%Q0.4	RIGHT		<input checked="" type="checkbox"/>
	%I0.0	POWER ON	POWER OFF	<input type="checkbox"/>

Delete a Page

This table explains how to delete a page in the **Display** tab:

Step	Action
1	Click the page that you want to delete under the Operator Interface node in the tree.
2	 <p>Click the (Delete Page) button, or right-click and choose Delete page. Result: A confirmation window appears.</p>
3	<p>Click Yes. Result: The page is deleted.</p>

Configure a Page

Overview

In the tree, the added page is represented as follows:

- Page ID
 - Elements
 - R1 key (if available)
 - R2 key (if available)
 - R3 key
 - R4 key (if available)

Page Properties

This procedure explains how to define the **Page properties**:

Step	Action	Comment
1	Click the page ID node in the tree. Result: The Page properties appear.	You can rename the page ID by double-clicking or right-clicking and choosing Rename page .
2	Enter a page title in the Title field.	–
3	Enter a help text in the Help text field if needed.	The help text is displayed when pressing the Information key on the Remote Graphic Display. ⁽¹⁾
4	Activate/deactivate the Password protect check box to protect this page with the password or to exclude this page from the protection.	For more information, refer to Password Protection (<i>see page 41</i>).
(1) If no text is entered, the Information key has no effect on this page.		

The **Page index** displayed is automatically generated by EcoStruxure Machine Expert - Basic and can be written in a user program to display the page, or read in a user program to detect the page currently being displayed.

For more information, refer to system word (%SW184) description (*see Modicon M221, Logic Controller, Programming Guide*).

Elements

The configuration of elements depends on the template.

Enter customized text and/or appropriate values according to each template. For more information, refer to Template Pages ([see page 62](#)).

You can add a maximum of 30 elements to a page.

This table describes the object types that can be entered in the **Variable**, **Unit**, **Minimum**, and **Maximum** fields for the template:

	%I	%Q	%IW	%QW	%IWS	%QWS	%M or %MWI. Xk	%S	%MW	%KW	%MD	%SW	Numeric value	Text
Variable/Variable1														
Monitor	x	x	x	x	x	x	x	x	x	x	x	x	-	-
Control table	x	x	-	-	-	-	x	x	-	-	-	-	-	-
Toggle Control table	x	x	-	-	-	-	x	x	-	-	-	-	-	-
Bargraph	-	-	x	x	-	-	-	-	x	-	x	x	-	-
Double Bargraph	-	-	x	x	-	-	-	-	x	-	x	x	-	-
VU meter	-	-	x	x	-	-	-	-	x	-	x	x	-	-
Variable/Variable2														
Double Bargraph	-	-	x	x	-	-	-	-	x	-	x	x	-	-
Unit														
Bargraph	-	-	-	-	-	-	-	-	-	-	-	-	-	x
Double Bargraph	-	-	-	-	-	-	-	-	-	-	-	-	-	x
VU meter	-	-	-	-	-	-	-	-	-	-	-	-	-	x

	%I	%Q	%IW	%QW	%IWS	%QWS	%M or %MWi. Xk	%S	%MW	%KW	%MD	%SW	Numeric value	Text
Minimum/Maximum														
Bargraph	-	-	-	-	-	-	-	-	-	-	-	-	x	-
Double Bargraph	-	-	-	-	-	-	-	-	-	-	-	-	x	-
VU meter	-	-	-	-	-	-	-	-	-	-	-	-	x	-

Fill in the fields following the rules described in Language Objects (*see EcoStruxure Machine Expert - Basic, Generic Functions Library Guide*).

R1, R2, R3, and R4 Key Assignments

When a key appears in the tree, you can assign an action and a label to it:

Step	Action
1	Select the key node in the tree.
2	Select the Action type that you want to associate with the key. For more information, refer to action (<i>see page 75</i>).
3	You can optionally rename the default label that is displayed above the corresponding key of the Remote Graphic Display. To do so, double-click the node or right-click and choose Rename .

NOTE: The templates have a key configured by default to go to the **Alarm View** page. You can choose to change the default action and the label of this key.

Export/Import a Page

Overview

Any page of the **Operator Interface** can be:

- Exported to the PC
- Imported from the PC

Export a Page

To export a page, click the  (**ExportPage**) button.
The page is saved in a specific format on your PC.

Import a Page

To import a page, click the  (**ImportPage**) button.
The page can then be imported in the same application, or in another application, with EcoStruxure Machine Expert - Basic.

Actions

Overview

An action can be associated to some keys:

- **R1, R2, R3, or R4 Key** (when available) for each page. Refer to R1, R2, R3, and R4 Key Assignments (*see page 73*).
- **F1 Key or F2 Key** for all the pages. Refer to F1 and F2 Key Assignments (*see page 61*).

The action is executed when pressing the keys.

Defining Actions

There are two types of actions:

- **Function**
- **Navigation**

Function

Forcing input and output values in a running logic controller can have serious consequences to the operation of a machine or process. Only those who understand the implications in the controlling logic, and who understand the consequences of forced I/O on the machine or process, should attempt to use this function.

WARNING

UNINTENDED EQUIPMENT OPERATION

You must have prior knowledge of the process and the controlled equipment before attempting to force logic controller physical inputs/outputs, or writing values to logic controller memory locations.

Failure to follow these instructions can result in death, serious injury, or equipment damage.

These functions are available:

- **WRITE_VALUE**
- **FORCE**
- **UNFORCE**
- **INCREMENT**
- **NOT**

This graphic presents an example of a function in the **Display** tab:

Key action assignment

Action type: Function

Function: FORCE

Variable: %Q0.5

Value: 0

Function Object Types

This table describes the object types that can be entered in the **Variable**, **Value**, **Increment Step**, **Minimum** and **Maximum** fields for the functions, when appropriate:

	%I	%Q	%IW	%QW	%IWS	%QWS	%M or %MWi. Xk	%S	%MW	%KW	%MD	%SW	Nu- meric value	Text
Variable														
WRITE_VALUE	-	x	-	x	-	-	x	x	x	-	x	x	-	-
FORCE	x	x	-	-	-	-	-	-	-	-	-	-	-	-
UNFORCE	x	x	-	-	-	-	-	-	-	-	-	-	-	-
INCREMENT	-	-	-	x	-	-	-	-	x	-	x	-	-	-
NOT	-	x	-	-	-	-	x	x	-	-	-	-	-	-
Value														
WRITE_VALUE	x	x	x	x	x	x	x	x	x	x	x	x	x	-
Increment Step														
INCREMENT	-	-	-	-	-	-	-	-	x	-	-	-	x	-
Minimum/Maximum														
INCREMENT	-	-	-	-	-	-	-	-	-	-	-	-	x	-

Fill in the fields following the rules described in the part Language Objects (*see EcoStruxure Machine Expert - Basic, Generic Functions Library Guide*).

Navigation

The **Navigation** action allows you to go to another page.

In a dropdown list, you can choose a **Destination page** that corresponds to:

- Any page defined in your **Operator Interface**
- A page from the **Setup**

Alarm Definition

Overview

The **Alarm View** page allows you to define a customized set of alarm messages associated with memory or I/O bits. The text of the alarm is then displayed on the Remote Graphic Display when a rising edge of the associated bit is detected. You can define a maximum of 20 alarm messages.

NOTE: Alarms are not saved when the controller goes through a power cycle.

For more information on the alarm in the Remote Graphic Display, refer to the Alarm Menu (*see page 49*).

Alarms have to be first configured in the **Alarm View > Elements** page of the **Display** tab in EcoStruxure Machine Expert - Basic.

Alarm Configuration

This graphic presents the **Alarm View > Elements** page of the **Display** tab:

Alarm View		dd/mm/yyyy HH:mm:ss
%I0.0:Machine door is open		
%I0.1:Power is OFF		
History		Back

Elements		
Variable	Alarm text	
<input type="text"/>	<input type="text"/>	<input type="button" value="Add"/>
%I0.0	Machine door is open	
%I0.1	Power is OFF	

Enter customized **Alarm text** and **Variable** values.

The object types that can be entered in the **Variable** field are:

- %I
- %Q
- %M
- %S
- %MWi.Xk

Fill in the field following the rules described in the part Language Objects (*see EcoStruxure Machine Expert - Basic, Generic Functions Library Guide*).



!

%I

According to the IEC standard, %I represents an input bit (for example, a language object of type digital IN).

%IW

According to the IEC standard, %IW represents an input word register (for example, a language object of type analog IN).

%KW

According to the IEC standard, %KW represents a constant word.

%MW

According to the IEC standard, %MW represents a memory word register (for example, a language object of type memory word).

%Q

According to the IEC standard, %Q represents an output bit (for example, a language object of type digital OUT).

%QW

According to the IEC standard, %QW represents an output word register (for example, a language object of type analog OUT).

%S

According to the IEC standard, %S represents a system bit.

%SW

According to the IEC standard, %SW represents a system word.

B

Boot application

(boot application) The binary file that contains the application. Usually, it is stored in the controller and allows the controller to boot on the application that the user has generated.

D

DWORD

(double word) Encoded in 32-bit format.

E

EN

EN identifies one of many European standards maintained by CEN (*European Committee for Standardization*), CENELEC (*European Committee for Electrotechnical Standardization*), or ETSI (*European Telecommunications Standards Institute*).

Ethernet

A physical and data link layer technology for LANs, also known as IEEE 802.3.

I

I/O

(*input/output*)

ID

(*identifier/identification*)

IEC

(*international electrotechnical commission*) A non-profit and non-governmental international standards organization that prepares and publishes international standards for electrical, electronic, and related technologies.

IP

(*Internet protocol*) Part of the TCP/IP protocol family that tracks the Internet addresses of devices, routes outgoing messages, and recognizes incoming messages.

M

master task

A processor task that is run through its programming software. The master task has 2 sections:

- **IN:** Inputs are copied to the IN section before execution of the master task.
- **OUT:** Outputs are copied to the OUT section after execution of the master task.

ms

(*millisecond*)

R

RJ45

A standard type of 8-pin connector for network cables defined for Ethernet.

RS-485

A standard type of serial communication bus, based on 2 wires (also known as EIA RS-485).

W

WORD

A type encoded in a 16-bit format.



A

action
 definition, 75
 function, 75
 key assignments, 61, 73
 navigation, 76
 object types, 76
adding/deleting pages in operator interface, 62
alarm
 alarm reset, 50
 configuration, 77
alarm history, 49
alarm view, 49
alarms, defining, 77

B

bargraph templates, 66

C

certifications and standards, 18
clearances, 24
connection, 29
control table templates, 65

D

description
 display, 15
 physical, 14
 system, 14
dimensions, 24
display tab
 button description, 59
 prerequisite, 56
 set properties, 60
 tree description, 59
double bargraph templates, 67

E

electromagnetic susceptibility, 17
enclosure requirements, 16
environmental characteristics, 16

F

function, 75
 object types, 76

G

general properties, 60
graphic screen, 38
grounding, 32

H

home page, 38

K

keys, assigning in operator interface, 75

M

menu templates, 63
monitor templates, 64
mounting, 26

O

object types, 52
operating interface
 creating, 55
operator interface
 adding/deleting pages in, 62
 assigning keys in, 75
 defining alarms in, 77

P

page

- add, *62*
- configuring, *71*
- deleting, *70*
- edit, *46*
- export, *74*
- home, *38*
- import, *74*
- properties, *71*

password

- management, *41*

password-protecting the Remote Graphic Display, *41*

pin assignment, *32*

properties, general, *60*

R

Remote Graphic Display firmware, updating, *35*

S

serial line configuration, *56*

setup menus, *43*

T

template

- elements, *72*

TMH2GDB

connecting the Remote Graphic Display, *29*

creating an operator interface for the, *55*

general properties of, *60*

operator interface, adding/deleting pages in, *62*

password-protecting the Remote Graphic Display, *41*

setup menus, *43*

using the Remote Graphic Display, *37*

toggle control table template, *69*

U

updating the Remote Graphic Display firmware, *35*

V

variable

add, *52*

delete, *52*

edit, *53, 53, 53, 54*

VU meter templates, *68*

Modicon TMC2

Cartridges

Programming Guide

12/2018

EIO0000003329.00

www.se.com



The information provided in this documentation contains general descriptions and/or technical characteristics of the performance of the products contained herein. This documentation is not intended as a substitute for and is not to be used for determining suitability or reliability of these products for specific user applications. It is the duty of any such user or integrator to perform the appropriate and complete risk analysis, evaluation and testing of the products with respect to the relevant specific application or use thereof. Neither Schneider Electric nor any of its affiliates or subsidiaries shall be responsible or liable for misuse of the information contained herein. If you have any suggestions for improvements or amendments or have found errors in this publication, please notify us.

You agree not to reproduce, other than for your own personal, noncommercial use, all or part of this document on any medium whatsoever without permission of Schneider Electric, given in writing. You also agree not to establish any hypertext links to this document or its content. Schneider Electric does not grant any right or license for the personal and noncommercial use of the document or its content, except for a non-exclusive license to consult it on an "as is" basis, at your own risk. All other rights are reserved.

All pertinent state, regional, and local safety regulations must be observed when installing and using this product. For reasons of safety and to help ensure compliance with documented system data, only the manufacturer should perform repairs to components.

When devices are used for applications with technical safety requirements, the relevant instructions must be followed.

Failure to use Schneider Electric software or approved software with our hardware products may result in injury, harm, or improper operating results.

Failure to observe this information can result in injury or equipment damage.

© 2018 Schneider Electric. All rights reserved.

Table of Contents



	Safety Information	5
	About the Book	7
Chapter 1	I/O Configuration General Information	9
	I/O Configuration General Practices	10
	General Description	11
	Using Cartridges in a Configuration	12
	Configuring Cartridges	13
Chapter 2	TMC2 Standard Cartridges Configuration	15
	TMC2AI2	16
	TMC2TI2	18
	TMC2AQ2V	21
	TMC2AQ2C	22
	TMC2SL1	23
Chapter 3	TMC2 Application Cartridges Configuration	29
	TMC2HOIS01	30
	TMC2PACK01	32
	TMC2CONV01	34
Chapter 4	TMC2 Analog Cartridge Diagnostics	39
	TMC2 Analog Cartridge Diagnostics	39
	Index	41

Safety Information



Important Information

NOTICE

Read these instructions carefully, and look at the equipment to become familiar with the device before trying to install, operate, service, or maintain it. The following special messages may appear throughout this documentation or on the equipment to warn of potential hazards or to call attention to information that clarifies or simplifies a procedure.



The addition of this symbol to a “Danger” or “Warning” safety label indicates that an electrical hazard exists which will result in personal injury if the instructions are not followed.



This is the safety alert symbol. It is used to alert you to potential personal injury hazards. Obey all safety messages that follow this symbol to avoid possible injury or death.

DANGER

DANGER indicates a hazardous situation which, if not avoided, **will result in** death or serious injury.

WARNING

WARNING indicates a hazardous situation which, if not avoided, **could result in** death or serious injury.

CAUTION

CAUTION indicates a hazardous situation which, if not avoided, **could result in** minor or moderate injury.

NOTICE

NOTICE is used to address practices not related to physical injury.

PLEASE NOTE

Electrical equipment should be installed, operated, serviced, and maintained only by qualified personnel. No responsibility is assumed by Schneider Electric for any consequences arising out of the use of this material.

A qualified person is one who has skills and knowledge related to the construction and operation of electrical equipment and its installation, and has received safety training to recognize and avoid the hazards involved.

About the Book



At a Glance

Document Scope

This document describes the software configuration of the TMC2 cartridges for logic controllers supported by EcoStruxure Machine Expert – Basic. For further information, refer to the separate documents provided in the EcoStruxure Machine Expert – Basic online help.

Validity Note

This document has been updated for the release of EcoStruxure™ Machine Expert - Basic V1.0.

Related Documents

Title of Documentation	Reference Number
EcoStruxure Machine Expert - Basic - Operating Guide	EIO0000003281 (ENG) EIO0000003282 (FRA) EIO0000003283 (GER) EIO0000003284 (SPA) EIO0000003285 (ITA) EIO0000003286 (CHS) EIO0000003287 (POR) EIO0000003288 (TUR)
Modicon M221 Logic Controller - Programming Guide	EIO0000003297 (ENG) EIO0000003298 (FRA) EIO0000003299 (GER) EIO0000003300 (SPA) EIO0000003301 (ITA) EIO0000003302 (CHS) EIO0000003303 (POR) EIO0000003304 (TUR)
Modicon M221 Logic Controller - Hardware Guide	EIO0000003313 (ENG) EIO0000003314 (FRA) EIO0000003315 (GER) EIO0000003316 (SPA) EIO0000003317 (ITA) EIO0000003318 (CHS) EIO0000003319 (POR) EIO0000003320 (TUR)

Title of Documentation	Reference Number
Modicon TMC2 Cartridges- Hardware Guide	EIO0000003337 (ENG) EIO0000003338 (FRA) EIO0000003339 (GER) EIO0000003340 (SPA) EIO0000003341 (ITA) EIO0000003342 (CHS) EIO0000003343 (POR) EIO0000003344 (TUR)

You can download these technical publications and other technical information from our website at <https://www.schneider-electric.com/en/download>

Product Related Information

 WARNING
<p>LOSS OF CONTROL</p> <ul style="list-style-type: none"> ● The designer of any control scheme must consider the potential failure modes of control paths and, for certain critical control functions, provide a means to achieve a safe state during and after a path failure. Examples of critical control functions are emergency stop and overtravel stop, power outage and restart. ● Separate or redundant control paths must be provided for critical control functions. ● System control paths may include communication links. Consideration must be given to the implications of unanticipated transmission delays or failures of the link. ● Observe all accident prevention regulations and local safety guidelines.¹ ● Each implementation of this equipment must be individually and thoroughly tested for proper operation before being placed into service. <p>Failure to follow these instructions can result in death, serious injury, or equipment damage.</p>

¹ For additional information, refer to NEMA ICS 1.1 (latest edition), "Safety Guidelines for the Application, Installation, and Maintenance of Solid State Control" and to NEMA ICS 7.1 (latest edition), "Safety Standards for Construction and Guide for Selection, Installation and Operation of Adjustable-Speed Drive Systems" or their equivalent governing your particular location.

 WARNING
<p>UNINTENDED EQUIPMENT OPERATION</p> <ul style="list-style-type: none"> ● Only use software approved by Schneider Electric for use with this equipment. ● Update your application program every time you change the physical hardware configuration. <p>Failure to follow these instructions can result in death, serious injury, or equipment damage.</p>

Chapter 1

I/O Configuration General Information

Introduction

This chapter provides general information to help you configure TMC2 cartridges in EcoStruxure Machine Expert – Basic.

What Is in This Chapter?

This chapter contains the following topics:

Topic	Page
I/O Configuration General Practices	10
General Description	11
Using Cartridges in a Configuration	12
Configuring Cartridges	13

I/O Configuration General Practices

Match Software and Hardware Configuration

The I/O that may be embedded in your controller is independent of the I/O that you may have added in the form of I/O expansion. It is important that the logical I/O configuration within your program matches the physical I/O configuration of your installation. If you add or remove any physical I/O to or from the I/O expansion bus or, depending on the controller reference, to or from the controller (in the form of cartridges), then you must update your application configuration. This is also true for any field bus devices you may have in your installation. Otherwise, there is the potential that the expansion bus or field bus no longer function while the embedded I/O that may be present in your controller continues to operate.

 WARNING
UNINTENDED EQUIPMENT OPERATION
Update the configuration of your program each time you add or delete any type of I/O expansions on your I/O bus, or you add or delete any devices on your field bus.
Failure to follow these instructions can result in death, serious injury, or equipment damage.

General Description

Introduction

The TMC2 cartridges connect to Modicon TM221C Logic Controllers to increase the number of I/Os or serial lines available on the controller.

Cartridges can be either:

- Analog cartridges
- Serial line cartridges

Cartridge Features

The following table describes the TMC2 cartridge features:

Reference	Description
TMC2AI2 <i>(see page 16)</i>	TMC2 cartridge with 2 analog voltage or current inputs (0...10 V, 0...20 mA, 4...20 mA), 12 bits
TMC2TI2 <i>(see page 18)</i>	TMC2 cartridge with 2 analog temperature inputs (thermocouple, RTD), 14 bits
TMC2AQ2V <i>(see page 21)</i>	TMC2 cartridge with 2 analog voltage outputs (0...10 V), 12 bits
TMC2AQ2C <i>(see page 22)</i>	TMC2 cartridge with 2 analog current outputs (4...20 mA), 12 bits
TMC2SL1 <i>(see page 23)</i>	TMC2 cartridge with 1 serial line (RS232 or RS485)
TMC2HOIS01 <i>(see page 30)</i>	TMC2 application cartridge with 2 analog voltage or current inputs for hoisting load cells
TMC2PACK01 <i>(see page 32)</i>	TMC2 application cartridge with 2 analog voltage or current inputs for packaging
TMC2CONV01 <i>(see page 34)</i>	TMC2 application cartridge with 1 serial line for conveying

Using Cartridges in a Configuration

Adding a Cartridge

TMC2 cartridges can be connected to Modicon TM221C Logic Controller with 1 or 2 cartridge slots.

NOTE: It is not possible to add 2 serial line cartridges to the same logic controller. For more information on cartridge compatibility with specific controllers, refer to the Hardware Guide of your logic controller.

The following steps explain how to add a cartridge to a logic controller in an EcoStruxure Machine Expert - Basic configuration:

Step	Description	Result
1	Click the Configuration tab in the EcoStruxure Machine Expert - Basic window.	–
2	In the hardware catalog area of the window, select M221 Cartridges .	–
3	Select a cartridge reference.	A description of the physical characteristics of the selected cartridge appears in the bottom right-hand corner of the EcoStruxure Machine Expert - Basic window.
4	Drag and drop the cartridge onto an empty cartridge slot of a Modicon TM221C Logic Controller logic controller.	The cartridge is added to the MyController → IO Bus area of the device tree. For serial line cartridges, the SL2 (Serial line) node appears. For analog cartridges, the Analog inputs or Analog outputs subnode appears immediately below the cartridge reference. The following information about the selected cartridge is displayed in the lower central area of the EcoStruxure Machine Expert - Basic window: <ul style="list-style-type: none"> ● Information about the current status of the cartridge. ● For application cartridges, a list of project templates available for the cartridge.

Replacing an Existing Cartridge

To replace an existing cartridge with a difference reference, drag and drop the new cartridge onto the cartridge to be replaced.

A message appears asking you to confirm the operation. Click **Yes** to continue.

Removing a Cartridge

To remove a cartridge from a controller, either click on the cartridge and press the **Delete** key, or right-click on the cartridge and click **Remove** on the contextual menu that appears.

If the cartridge contains at least one address being used in the user logic of the program, a message appears asking you to confirm the operation. Click **Yes** to continue.

Configuring Cartridges

Overview

You can configure cartridges on:

- The **Configuration** tab
- The **Programming** tab

Displaying Configuration Details

The **Configuration** tab allows you to configure cartridge modules.

The steps below describe how to view the configuration of digital inputs on the **Configuration** tab:

Step	Description
1	Select the Configuration tab.
2	For analog cartridges, select Cartridge 1 or Cartridge 2 in the device tree on the left of the EcoStruxure Machine Expert - Basic window then click on the Analog inputs or Analog outputs subnode. For serial line cartridges, select SL2 (Serial line) in the device tree on the left of the EcoStruxure Machine Expert - Basic window The properties of the selected cartridge are displayed.
3	Refer to TMC2 Standard Cartridges Configuration (<i>see page 15</i>) or TMC2 Application Cartridges Configuration (<i>see page 29</i>) for configuration details.

Displaying Programming Properties

The **Programming** tab allows you to configure programming-related properties of analog cartridges, such as symbols and comments.

To display analog cartridge properties in the **Programming** tab:

Step	Description
1	Select the Programming tab.
2	Click Tools → I/O objects → Analog inputs or Tools → I/O objects → Analog outputs A list of I/O addresses appears in the lower central area of the EcoStruxure Machine Expert - Basic window.
3	Scroll down to the range of addresses corresponding to the cartridge you are configuring. The following properties are displayed: <ul style="list-style-type: none">● Used. Whether the address is being used in your program● Address. The analog input or analog output address. Refer to I/O Addressing (<i>see EcoStruxure Machine Expert - Basic, Generic Functions Library Guide</i>) for details.● Symbol. An optional symbol associated with the address. Double-click in the Symbol column and type the name of a symbol to associate with this input. If a symbol already exists, right-click in the Symbol column and choose Search and Replace to find and replace occurrences of this symbol in the application.● Comment. An optional comment associated with the address. Double-click in the Comment column and type a comment to associate with this address.

Chapter 2

TMC2 Standard Cartridges Configuration

Introduction

This chapter describes how to configure the TMC2 standard cartridges.

What Is in This Chapter?

This chapter contains the following topics:

Topic	Page
TMC2AI2	16
TMC2TI2	18
TMC2AQ2V	21
TMC2AQ2C	22
TMC2SL1	23

TMC2AI2

Introduction

The TMC2AI2 is a standard cartridge featuring 2 analog voltage or current input channels with 12-bit resolution.

The channel input types are:

- 0...10 V
- 0...20 mA
- 4...20 mA

For further hardware information, refer to TMC2AI2 (*see Modicon TMC2, Cartridges, Hardware Guide*).

If you have physically wired the analog channel for a voltage signal and you configure the channel for a current signal in EcoStruxure Machine Expert - Basic, you may damage the analog circuit.

NOTICE

INOPERABLE EQUIPMENT

Verify that the physical wiring of the analog circuit is compatible with the software configuration for the analog channel.

Failure to follow these instructions can result in equipment damage.

Configuring the Module

For each input, you can define:

Parameter	Value	Default Value	Description
Used	True/False	False	Indicates whether the address is being used in a program.
Address	%IW0.x0y	-	The address of the input channel, where <i>x</i> is the module number and <i>y</i> is the channel number
Type	Not used 0 - 10 V 0 - 20 mA 4 - 20 mA	Not used	Select the mode of the channel.
Scope	Normal	Normal	The range of values for a channel.
Min.	0 - 10 V	-32768...32767	Specifies the lower measurement limit.
	0 - 20 mA	0	
	4 - 20 mA	4000	
Max.	0 - 10 V	-32768...32767	Specifies the upper measurement limit.
	0 - 20 mA	10000	
	4 - 20 mA	20000	
Filter	0...100	0	Specifies the filtering value. Multiply by the Filter Unit value to obtain the filtering time.
Filter Unit	100 ms	100 ms	Specifies the unit of time for the filtering value.
Units	-	-	-

TMC2TI2

Introduction

The TMC2TI2 is a standard cartridge featuring 2 analog input channels with 14-bit resolution.

The channel input types are:

- K Thermocouple
- J Thermocouple
- R Thermocouple
- S Thermocouple
- B Thermocouple
- E Thermocouple
- T Thermocouple
- N Thermocouple
- C Thermocouple
- PT100
- PT1000
- NI100
- NI1000

For further hardware information, refer to TMC2TI2 (*see Modicon TMC2, Cartridges, Hardware Guide*).

If you have physically wired the analog channel for a voltage signal and you configure the channel for a current signal in EcoStruxure Machine Expert - Basic, you may damage the analog circuit.

NOTICE

INOPERABLE EQUIPMENT

Verify that the physical wiring of the analog circuit is compatible with the software configuration for the analog channel.

Failure to follow these instructions can result in equipment damage.

Configuring the Module

For each input, you can define:

Parameter	Value	Default Value	Description
Used	True/False	False	Indicates whether the address is being used in a program.
Address	%IW0.x0y	-	The address of the input channel, where <i>x</i> is the module number and <i>y</i> is the channel number
Type	K Thermocouple J Thermocouple R Thermocouple S Thermocouple B Thermocouple E Thermocouple T Thermocouple N Thermocouple C Thermocouple PT100 PT1000 NI100 NI1000	K Thermocouple	Choose the mode of the channel.
Scope	Normal Celsius (0.1°C) Fahrenheit (0.1°F) (except Thermocouple B and C) Fahrenheit (0.2°F) (for Thermocouple B and C only)	Normal	Choose the temperature units for a channel.
Min.	Temperature	See the table below	Specifies the lower measurement limit.
Max.	Temperature	See the table below	Specifies the upper measurement limit.
Filter	0...100	0	Specifies the filtering value. Multiply by the Filter Unit value to obtain the filtering time.
Filter Unit	100 ms	100 ms	Specifies the unit of time for the filtering value.
Units	See the table below		Displays the temperature unit configured.

TMC2 Standard Cartridges Configuration

Type	Customized		Celsius			Fahrenheit		
	Min.	Max.	Min.	Max.	Units	Min.	Max.	Units
K Thermocouple	-32768	32767	-2000	13000	0.1 °C	-3280	23720	0.1 °F
J Thermocouple	-32768	32767	-2000	10000	0.1 °C	-3280	18320	0.1 °F
R Thermocouple	-32768	32767	0	17600	0.1 °C	320	32000	0.1 °F
S Thermocouple	-32768	32767	0	17600	0.1 °C	320	32000	0.1 °F
B Thermocouple	-32768	32767	0	18200	0.1 °C	160	16540	0.2 °F
E Thermocouple	-32768	32767	-2000	8000	0.1 °C	-3280	14720	0.1 °F
T Thermocouple	-32768	32767	-2000	4000	0.1 °C	-3280	7520	0.1 °F
N Thermocouple	-32768	32767	-2000	13000	0.1 °C	-3280	23720	0.1 °F
C Thermocouple	-32768	32767	0	23150	0.1 °C	160	20995	0.2 °F
PT100	-32768	32767	-2000	8500	0.1 °C	-3280	15620	0.1 °F
PT1000	-32768	32767	-2000	6000	0.1 °C	-3280	11120	0.1 °F
NI100	-32768	32767	-600	1800	0.1 °C	-760	3560	0.1 °F
NI1000	-32768	32767	-600	1800	0.1 °C	-760	3560	0.1 °F

TMC2AQ2V

Introduction

The TMC2AQ2V is a standard cartridge featuring 2 analog voltage output channels with 12-bit resolution.

The channel output types are:

- 0...10 V

For further hardware information, refer to TMC2AQ2V (*see Modicon TMC2, Cartridges, Hardware Guide*).

If you have physically wired the analog channel for a voltage signal and you configure the channel for a current signal in EcoStruxure Machine Expert - Basic, you may damage the analog circuit.

NOTICE

INOPERABLE EQUIPMENT

Verify that the physical wiring of the analog circuit is compatible with the software configuration for the analog channel.

Failure to follow these instructions can result in equipment damage.

Configuring the Cartridge Module

For each output, you can define:

Parameter	Value	Default Value	Description	
Used	True/False	False	Indicates whether the address is being used in a program.	
Address	%QW0 . x0y	-	Shows the address of the output channel, where <i>x</i> is the cartridge number and <i>y</i> is the channel number	
Type	0 - 10 V	0 - 10 V	The mode of the channel.	
Scope	Normal	Normal	The range of values for a channel.	
Min.	0 - 10 V	-32768...32767	0	Specifies the lower measurement limit.
Max.	0 - 10 V	-32768...32767	10000	Specifies the upper measurement limit.
Fallback value	Min...Max.	0 (Min. if 0 is not in the range)	Specifies the fallback value of the output channel.	
Units	-	-	-	

TMC2AQ2C

Introduction

The TMC2AQ2C is a standard cartridge featuring 2 analog current output channels with 12-bit resolution.

The channel output types are:

- 4...20 mA

For further hardware information, refer to TMC2AQ2C (*see Modicon TMC2, Cartridges, Hardware Guide*).

If you have physically wired the analog channel for a voltage signal and you configure the channel for a current signal in EcoStruxure Machine Expert - Basic, you may damage the analog circuit.

NOTICE

INOPERABLE EQUIPMENT

Verify that the physical wiring of the analog circuit is compatible with the software configuration for the analog channel.

Failure to follow these instructions can result in equipment damage.

Configuring the Cartridge Module

For each output, you can define:

Parameter		Value	Default Value	Description
Used		True/False	False	Indicates whether the address is being used in a program.
Address		%QW0 . x0y	-	Shows the address of the output channel, where <i>x</i> is the cartridge number and <i>y</i> is the channel number
Type		4 - 20 mA	4 - 20 mA	The mode of the channel.
Scope		Normal	Normal	The range of values for a channel.
Min.	4 - 20 mA	-32768...32767	4000	Specifies the lower measurement limit.
Max.	4 - 20 mA	-32768...32767	20000	Specifies the upper measurement limit.
Fallback value		Min...Max.	0 (Min. if 0 is not in the range)	Specifies the fallback value of the output channel.
Units			-	-

TMC2SL1

Introduction

The TMC2SL1 is a standard cartridge module featuring 1 serial line.

For further hardware information, refer to TMC2SL1 (*see Modicon TMC2, Cartridges, Hardware Guide*).

The serial line can be configured for any one of the following protocols:

- Modbus RTU
- Modbus ASCII
- ASCII

You can configure both physical and protocol settings for the serial line. Serial lines are configured for the Modbus RTU protocol by default.

NOTE: You can only add one serial line cartridge to the controller.

Serial Line Configuration

This table describes how to configure the serial line:

Step	Action
1	<p>Click the SL2 (Serial line) node in the Hardware Tree to display the serial line properties. This figure shows the properties of the serial line for Modbus RTU and Modbus ASCII protocols:</p> <div data-bbox="293 342 1140 764" style="border: 1px solid #ccc; padding: 10px;"> <p>Serial line configuration</p> <div style="display: flex; justify-content: space-between;"> <div style="width: 48%;"> <p>Physical Settings</p> <p>Baud rate: 19200</p> <p>Parity: Even</p> <p>Data bits: 8</p> <p>Stop bits: 1</p> <p>Physical medium</p> <p><input checked="" type="radio"/> RS-485 Polarization: No</p> <p><input type="radio"/> RS-232</p> </div> <div style="width: 48%;"> <p>Protocol Settings</p> <p>Protocol: Modbus RTU</p> <p>Addressing: <input checked="" type="radio"/> Slave Address [1...247]: 1</p> <p><input type="radio"/> Master</p> <p>Response time (x 100 ms): 10</p> <p>Time between frames (ms): 10</p> </div> </div> <p style="text-align: right;">Apply Cancel</p> </div> <p>This figure shows the properties of the serial line for ASCII protocol:</p> <div data-bbox="293 841 1140 1377" style="border: 1px solid #ccc; padding: 10px;"> <p>Serial line configuration</p> <div style="display: flex; justify-content: space-between;"> <div style="width: 48%;"> <p>Physical Settings</p> <p>Baud rate: 19200</p> <p>Parity: Even</p> <p>Data bits: 8</p> <p>Stop bits: 1</p> <p>Physical medium</p> <p><input checked="" type="radio"/> RS-485 Polarization: No</p> <p><input type="radio"/> RS-232</p> </div> <div style="width: 48%;"> <p>Protocol Settings</p> <p>Protocol: ASCII</p> <p>Response time (x 100 ms): 10</p> <p>Stop condition</p> <p><input type="checkbox"/> Frame length received: 0</p> <p><input type="checkbox"/> Frame received timeout (ms): 0</p> <p>Frame structure</p> <p><input type="checkbox"/> Start character: 0</p> <p><input checked="" type="checkbox"/> First end character: 10 <LF></p> <p><input type="checkbox"/> Second end character: 0</p> <p><input type="checkbox"/> Send frame characters</p> </div> </div> <p style="text-align: right;">Apply Cancel</p> </div>

This table describes each parameter of the serial line:

Parameter	Editable	Value	Default Value	Description
Physical settings				
Baud rate	Yes	1200 2400 4800 9600 19200 38400 57600 115200	19200	Allows you to select the data transmission rate (bits per second) for the modem from the drop-down list.
Parity	Yes	None Even Odd	Even	Allows you to select the parity of the transmitted data for error detection. Parity is a method of error detection in transmission. When parity is used with a serial port, an extra data bit is sent with each data character, arranged so that the number of 1 bits in each character, including the parity bit, is always odd or always even. If a byte is received with the wrong number of 1 bits, the byte is corrupt. However, an even number of detected errors can pass the parity check.
Data bits	Yes (only for the ASCII protocol)	7 8	7 for Modbus ASCII, 8 for Modbus RTU	Allows you to select the number of data bits from the drop-down list. The number of data bits in each character can be 7 (for true ASCII) or 8 (for any kind of data, as this matches the size of a byte). 8 data bits are almost universally used in all applications.
Stop bits	Yes	1 2	1	Allows you to select the number of stop bits from the drop-down list. A stop bit is a bit indicating the end of a byte of data. For electronic devices, 1 stop bit is usually used. For slow devices like electromechanical teleprinters, 2 stop bits are used.

Parameter	Editable	Value	Default Value	Description
Physical medium	Yes	RS485 True/False RS232 True/False	RS485 True	Allows you to select the physical medium for communication. You can only select either the RS485 or RS232 medium. Enabling one medium disables the other one. A physical medium in data communications is the transmission path over which a signal propagates. It is an interface for interconnection of devices with the logic controller.
Polarization	Yes	Yes No	No	Polarization resistors are integrated in the cartridge module. Specify whether to switch on or off polarization.
Protocol settings				
Protocol	Yes	Modbus RTU Modbus ASCII ASCII	Modbus RTU	Allows you to select the protocol transmission mode for communication from the drop-down list. Protocol advanced parameters are displayed based on the selected protocol. Refer to the following figures and tables.
Protocol settings for the Modbus RTU and Modbus ASCII protocols:				
Addressing	Yes	Slave Master	Slave	Allows you to select the addressing mode. You can only select either of the Slave or Master addressing. Enabling one addressing mode disables the other one.
Address [1...247]	Yes	1...247	1	Allows you to specify the address ID of the slave. NOTE: This field is displayed only for the addressing of the slave. For master, this field does not appear on the screen.
Response time (x 100 ms)	Yes	10...255 ms	10	Allows you to specify the response time of the protocol to the queries.
Time between frames (ms)	Yes	3...255 ms	10	Allows you to specify the time between frames of the protocol.

Parameter	Editable	Value	Default Value	Description
Protocol settings for the ASCII protocol:				
Stop condition				
Response time (x 100 ms)	Yes	1...255	10	Allows you to specify the response time of the protocol to the queries.
Frame length received	Yes	0...255	0	Allows you to specify the frame length received.
Frame received timeout (ms)	Yes	0...255	10	Allows you to specify the frame received timeout.
Frame structure				
Start character	Yes	0...255	58 (if check box is selected)	Allows you to specify the start character of the frame.
First end character	Yes	0...255	10 (if check box is selected)	Allows you to specify the first end character of the frame.
Second end character	Yes	0...255	10 (if check box is selected)	Allows you to specify the second end character of the frame.
Send frame characters	Yes	True/False	False	Allows you to enable or disable sending first end character of the frame to the ASCII protocol.

Chapter 3

TMC2 Application Cartridges Configuration

Introduction

This chapter describes how to configure the TMC2 application cartridges.

What Is in This Chapter?

This chapter contains the following topics:

Topic	Page
TMC2HOIS01	30
TMC2PACK01	32
TMC2CONV01	34

TMC2HOIS01

Introduction

The TMC2HOIS01 is an application cartridge module for hoisting, featuring 2 analog voltage or current input channels with 12-bit resolution.

The channel input types are:

- 0...10 V
- 0...20 mA
- 4...20 mA

For further hardware information, refer to TMC2HOIS01 (*see Modicon TMC2, Cartridges, Hardware Guide*).

If you have physically wired the analog channel for a voltage signal and you configure the channel for a current signal in EcoStruxure Machine Expert - Basic, you may damage the analog circuit.

NOTICE

INOPERABLE EQUIPMENT

Verify that the physical wiring of the analog circuit is compatible with the software configuration for the analog channel.

Failure to follow these instructions can result in equipment damage.

Configuring the Module

For each input, you can define:

Parameter		Value	Default Value	Description
Used		True/False	False	Indicates whether the address is being used in a program.
Address		%IW0.x0y	-	The address of the input channel, where <i>x</i> is the module number and <i>y</i> is the channel number
Type		Not used 0 - 10 V 0 - 20 mA 4 - 20 mA	Not used	Choose the mode of the channel.
Scope		Customized	Customized	The range of values for a channel.
Min.	0 - 10 V	-32768...32767	0	Specifies the lower measurement limit.
	0 - 20 mA		0	
	4 - 20 mA		4000	
Max.	0 - 10 V	-32768...32767	10000	Specifies the upper measurement limit.
	0 - 20 mA		20000	
	4 - 20 mA		20000	
Filter		0...100	0	Specifies the filtering value. Multiply by the Filter Unit value to obtain the filtering time.
Filter Unit		100 ms	100 ms	Specifies the unit of time for the filtering value.
Units)		-	-	-

TMC2PACK01

Introduction

The TMC2PACK01 is an application cartridge module for packaging, featuring 2 analog voltage or current input channels with 12-bit resolution.

The channel input types are:

- 0...10 V
- 0...20 mA
- 4...20 mA

For further hardware information, refer to TMC2PACK01 (*see Modicon TMC2, Cartridges, Hardware Guide*).

If you have physically wired the analog channel for a voltage signal and you configure the channel for a current signal in EcoStruxure Machine Expert - Basic, you may damage the analog circuit.

<h2><i>NOTICE</i></h2>
<p>INOPERABLE EQUIPMENT</p> <p>Verify that the physical wiring of the analog circuit is compatible with the software configuration for the analog channel.</p> <p>Failure to follow these instructions can result in equipment damage.</p>

Configuring the Module

For each input, you can define:

Parameter		Value	Default Value	Description
Used		True/False	False	Indicates whether the address is being used in a program.
Address		%IW0.x0y	-	The address of the input channel, where <i>x</i> is the module number and <i>y</i> is the channel number
Type		Not used 0 - 10 V 0 - 20 mA 4 - 20 mA	Not used	Choose the mode of the channel.
Scope		Customized	Customized	The range of values for a channel.
Min.	0 - 10 V	-32768...32767	0	Specifies the lower measurement limit.
	0 - 20 mA		0	
	4 - 20 mA		4000	
Max.	0 - 10 V	-32768...32767	10000	Specifies the upper measurement limit.
	0 - 20 mA		20000	
	4 - 20 mA		20000	
Filter (x 100ms)		0...100	0	Specifies the filtering time (0...10 s).
Units		-	-	-

TMC2CONV01

Introduction

The TMC2CONV01 is an application cartridge module featuring 1 serial line for conveying. For further hardware information, refer to TMC2CONV01 (*see Modicon TMC2, Cartridges, Hardware Guide*).

The serial line can be configured for any one of the following protocols:

- Modbus RTU
- Modbus ASCII
- ASCII

You can configure both physical and protocol settings for the serial line. Serial lines are configured for the Modbus RTU protocol by default.

NOTE: You can only add one serial line cartridge to the controller.

Serial Line Configuration

This table describes how to configure the serial line:

Step	Action
1	<p>Click the SL2 (Serial line) node in the Hardware Tree to display the serial line properties. This figure shows the properties of the serial line for Modbus RTU and Modbus ASCII protocols:</p> <div data-bbox="322 341 1173 771"> <p>Serial line configuration</p> <div style="display: flex; justify-content: space-between;"> <div style="width: 48%;"> <p>Physical Settings</p> <p>Baud rate: 19200</p> <p>Parity: Even</p> <p>Data bits: 8</p> <p>Stop bits: 1</p> <p>Physical medium</p> <p><input checked="" type="radio"/> RS-485 Polarization: No</p> <p><input type="radio"/> RS-232</p> </div> <div style="width: 48%;"> <p>Protocol Settings</p> <p>Protocol: Modbus RTU</p> <p>Addressing: <input checked="" type="radio"/> Slave Address [1...247]: 1</p> <p><input type="radio"/> Master</p> <p>Response time (x 100 ms): 10</p> <p>Time between frames (ms): 10</p> </div> </div> <p style="text-align: right;">Apply Cancel</p> </div> <p>This figure shows the properties of the serial line for ASCII protocol:</p> <div data-bbox="322 836 1173 1372"> <p>Serial line configuration</p> <div style="display: flex; justify-content: space-between;"> <div style="width: 48%;"> <p>Physical Settings</p> <p>Baud rate: 19200</p> <p>Parity: Even</p> <p>Data bits: 8</p> <p>Stop bits: 1</p> <p>Physical medium</p> <p><input checked="" type="radio"/> RS-485 Polarization: No</p> <p><input type="radio"/> RS-232</p> </div> <div style="width: 48%;"> <p>Protocol Settings</p> <p>Protocol: ASCII</p> <p>Response time (x 100 ms): 10</p> <p>Stop condition</p> <p><input type="checkbox"/> Frame length received: 0</p> <p><input type="checkbox"/> Frame received timeout (ms): 0</p> <p>Frame structure</p> <p><input type="checkbox"/> Start character: 0</p> <p><input checked="" type="checkbox"/> First end character: 10 <LF></p> <p><input type="checkbox"/> Second end character: 0</p> <p><input type="checkbox"/> Send frame characters</p> </div> </div> <p style="text-align: right;">Apply Cancel</p> </div>

This table describes each parameter of the serial line:

Parameter	Editable	Value	Default Value	Description
Physical settings				
Baud rate	Yes	1200 2400 4800 9600 19200 38400 57600 115200	19200	Allows you to select the data transmission rate (bits per second) for the modem from the drop-down list.
Parity	Yes	None Even Odd	Even	Allows you to select the parity of the transmitted data for error detection. Parity is a method of error detection in transmission. When parity is used with a serial port, an extra data bit is sent with each data character, arranged so that the number of 1 bits in each character, including the parity bit, is always odd or always even. If a byte is received with the wrong number of 1 bits, the byte is corrupt. However, an even number of detected errors can pass the parity check.
Data bits	Yes (only for the ASCII protocol)	7 8	7 for Modbus ASCII, 8 for Modbus RTU	Allows you to select the number of data bits from the drop-down list. The number of data bits in each character can be 7 (for true ASCII) or 8 (for any kind of data, as this matches the size of a byte). 8 data bits are almost universally used in all applications.
Stop bits	Yes	1 2	1	Allows you to select the number of stop bits from the drop-down list. A stop bit is a bit indicating the end of a byte of data. For electronic devices, 1 stop bit is usually used. For slow devices like electromechanical teleprinters, 2 stop bits are used.

Parameter	Editable	Value	Default Value	Description
Physical medium	Yes	RS485 True/False RS232 True/False	RS485 True	Allows you to select the physical medium for communication. You can only select either the RS485 or RS232 medium. Enabling one medium disables the other one. A physical medium in data communications is the transmission path over which a signal propagates. It is an interface for interconnection of devices with the logic controller.
Polarization	Yes	Yes No	No	Polarization resistors are integrated in the cartridge module. Specify whether to switch on or off polarization.
Protocol settings				
Protocol	Yes	Modbus RTU Modbus ASCII ASCII	Modbus RTU	Allows you to select the protocol transmission mode for communication from the drop-down list. Protocol advanced parameters are displayed based on the selected protocol. Refer to the following figures and tables.
Protocol settings for the Modbus RTU and Modbus ASCII protocols:				
Addressing	Yes	Slave Master	Slave	Allows you to select the addressing mode. You can only select either of the Slave or Master addressing. Enabling one addressing mode disables the other one.
Address [1...247]	Yes	1...247	1	Allows you to specify the address ID of the slave. NOTE: This field is displayed only for the addressing of the slave. For master, this field does not appear on the screen.
Response time (x 100 ms)	Yes	10...255 ms	10	Allows you to specify the response time of the protocol to the queries.
Time between frames (ms)	Yes	3...255 ms	10	Allows you to specify the time between frames of the protocol.

Parameter	Editable	Value	Default Value	Description
Protocol settings for the ASCII protocol:				
Stop condition				
Response time (x 100 ms)	Yes	1...255	10	Allows you to specify the response time of the protocol to the queries.
Frame length received	Yes	0...255	0	Allows you to specify the frame length received.
Frame received timeout (ms)	Yes	0...255	10	Allows you to specify the frame received timeout.
Frame structure				
Start character	Yes	0...255	58 (if check box is selected)	Allows you to specify the start character of the frame.
First end character	Yes	0...255	10 (if check box is selected)	Allows you to specify the first end character of the frame.
Second end character	Yes	0...255	10 (if check box is selected)	Allows you to specify the second end character of the frame.
Send frame characters	Yes	True/False	False	Allows you to enable or disable sending first end character of the frame to the ASCII protocol.

Chapter 4

TMC2 Analog Cartridge Diagnostics

TMC2 Analog Cartridge Diagnostics

Introduction

For analog cartridges, the operating status of each I/O channel is given by the objects:

- %IWS0.x0y for input channel *y* of cartridge *x*
- %QWS0.x0y for output channel *y* of cartridge *x*

The real-time values of these objects can be read when in online mode, using either an animation table (*see EcoStruxure Machine Expert - Basic, Operating Guide*) or the application.

Input Channel Status Description

This table describes the possible values of the %IWS input channel status word:

Byte value	Description
0	Normal
1	Data conversion in progress
2	Initialization
3	Input operation setting error or cartridge with no input
4	Undefined
5	Wiring error detected (input voltage/current high limit exceeded).
6	Wiring error detected (input voltage/current low limit exceeded).
7	Non-volatile memory error
8...255	Undefined

Output Channel Status Description

This table describes the possible values of the %QWS output channel status word:

Byte value	Description
0	Normal
1	Undefined
2	Initialization
3	Output operation setting error or cartridge with no output
4	Undefined
5	Undefined
6	Undefined
7	Non-volatile memory error
8...255	Undefined



Symbols

%IWS input channel status, *39*
%QWS output channel status, *39*

A

analog cartridges, *11*
application cartridges
 TMC2CONV01, *34*
 TMC2HOIS01, *30*
 TMC2PACK01, *32*

C

cartridge
 adding to an EcoStruxure Machine Expert
 - Basic configuration, *12*
 configuring, *13*
 description, *11*
 features, *11*
 removing, *12*
 replacing, *12*
comments
 displaying, *14*
configuring
 cartridges, *13*
conveying application cartridge, *34*

D

description
 cartridge, *11*
device tree, *12*
diagnostic bytes (%IWS, %QWS), *39*
displaying
 programming details, *14*

E

EcoStruxure Machine Expert - Basic
 device tree, *12*
 project, *12*

F

features
 cartridge, *11*

H

hoisting application cartridge, *30*

I

I/O configuration general information
 general practices, *10*
input channel status (%IWS), *39*

O

output channel status (%QWS), *39*

P

packaging application cartridge, *32*
programming details
 displaying, *14*

R

removing a cartridge, *12*
replacing
 a cartridge, *12*

S

serial line

configuration, *24, 35*

introduction, *23, 34*

serial line cartridges, *11, 23, 34*

symbols, displaying, *14*

T

TMC2 analog cartridges

diagnostics, *39*

TMC2 analog I/O modules

TMC2AI2, *16*

TMC2AQ2C, *22*

TMC2AQ2V, *21*

TMC2HOIS01, *30*

TMC2PACK01, *32*

TMC2TI2, *18*

TMC2 cartridges

adding to a configuration, *12*

TMC2AI2, *16*

TMC2AQ2C, *22*

TMC2AQ2V, *21*

TMC2CONV01, *34*

TMC2HOIS01, *30*

TMC2PACK01, *32*

TMC2SL1, *23*

TMC2TI2, *18*

Modicon TMC2 Cartridges

Hardware Guide

12/2018

EIO0000003337.00

www.se.com

Schneider
 Electric™

The information provided in this documentation contains general descriptions and/or technical characteristics of the performance of the products contained herein. This documentation is not intended as a substitute for and is not to be used for determining suitability or reliability of these products for specific user applications. It is the duty of any such user or integrator to perform the appropriate and complete risk analysis, evaluation and testing of the products with respect to the relevant specific application or use thereof. Neither Schneider Electric nor any of its affiliates or subsidiaries shall be responsible or liable for misuse of the information contained herein. If you have any suggestions for improvements or amendments or have found errors in this publication, please notify us.

You agree not to reproduce, other than for your own personal, noncommercial use, all or part of this document on any medium whatsoever without permission of Schneider Electric, given in writing. You also agree not to establish any hypertext links to this document or its content. Schneider Electric does not grant any right or license for the personal and noncommercial use of the document or its content, except for a non-exclusive license to consult it on an "as is" basis, at your own risk. All other rights are reserved.

All pertinent state, regional, and local safety regulations must be observed when installing and using this product. For reasons of safety and to help ensure compliance with documented system data, only the manufacturer should perform repairs to components.

When devices are used for applications with technical safety requirements, the relevant instructions must be followed.

Failure to use Schneider Electric software or approved software with our hardware products may result in injury, harm, or improper operating results.

Failure to observe this information can result in injury or equipment damage.

© 2018 Schneider Electric. All rights reserved.

Table of Contents



	Safety Information	5
	About the Book	7
Part I	TMC2 General Overview	13
Chapter 1	TMC2 Description	15
	General Description	15
Chapter 2	TMC2 Installation	17
2.1	TMC2 General Rules for Implementing	18
	Environmental Characteristics	19
	Certifications and Standards	20
2.2	TMC2 Installation	21
	Installation and Maintenance Requirements	22
	TMC2 Installation	24
2.3	TMC2 Electrical Requirements	30
	Wiring Best Practices	31
	Grounding the M221 System	34
Part II	TMC2 Standard Cartridges	37
Chapter 3	TMC2AI2 Analog Voltage, Current Inputs	39
	TMC2AI2 Presentation	40
	TMC2AI2 Characteristics	41
	TMC2AI2 Wiring Diagram	43
Chapter 4	TMC2TI2 Analog Temperature Inputs	45
	TMC2TI2 Presentation	46
	TMC2TI2 Characteristics	47
	TMC2TI2 Wiring Diagram	50
Chapter 5	TMC2AQ2V Analog Voltage Outputs	51
	TMC2AQ2V Presentation	52
	TMC2AQ2V Characteristics	53
	TMC2AQ2V Wiring Diagram	55
Chapter 6	TMC2AQ2C Analog Current Outputs	57
	TMC2AQ2C Presentation	58
	TMC2AQ2C Characteristics	59
	TMC2AQ2C Wiring Diagram	61

Chapter 7	TMC2SL1 Serial Line	63
	TMC2SL1 Presentation	64
	TMC2SL1 Characteristics	65
	TMC2SL1 Wiring Diagram	67
Part III	TMC2 Application Cartridges	69
Chapter 8	TMC2HOIS01 Hoisting	71
	TMC2HOIS01 Presentation	72
	TMC2HOIS01 Characteristics	73
	TMC2HOIS01 Wiring Diagram	75
Chapter 9	TMC2PACK01 Packaging	77
	TMC2PACK01 Presentation	78
	TMC2PACK01 Characteristics	79
	TMC2PACK01 Wiring Diagram	81
Chapter 10	TMC2CONV01 Conveying	83
	TMC2CONV01 Presentation	84
	TMC2CONV01 Characteristics	85
	TMC2CONV01 Wiring Diagram	87
Glossary	89
Index	91

Safety Information



Important Information

NOTICE

Read these instructions carefully, and look at the equipment to become familiar with the device before trying to install, operate, service, or maintain it. The following special messages may appear throughout this documentation or on the equipment to warn of potential hazards or to call attention to information that clarifies or simplifies a procedure.



The addition of this symbol to a “Danger” or “Warning” safety label indicates that an electrical hazard exists which will result in personal injury if the instructions are not followed.



This is the safety alert symbol. It is used to alert you to potential personal injury hazards. Obey all safety messages that follow this symbol to avoid possible injury or death.

DANGER

DANGER indicates a hazardous situation which, if not avoided, **will result in** death or serious injury.

WARNING

WARNING indicates a hazardous situation which, if not avoided, **could result in** death or serious injury.

CAUTION

CAUTION indicates a hazardous situation which, if not avoided, **could result** in minor or moderate injury.

NOTICE

NOTICE is used to address practices not related to physical injury.

PLEASE NOTE

Electrical equipment should be installed, operated, serviced, and maintained only by qualified personnel. No responsibility is assumed by Schneider Electric for any consequences arising out of the use of this material.

A qualified person is one who has skills and knowledge related to the construction and operation of electrical equipment and its installation, and has received safety training to recognize and avoid the hazards involved.

About the Book



At a Glance

Document Scope

This guide describes the hardware implementation of TMC2. It provides the parts description, characteristics, wiring diagrams, and installation details for TMC2.

Validity Note

The information in this manual is applicable **only** for TMC2 products.

This document has been updated for the release of EcoStruxure™ Machine Expert - Basic V1.0.

For product compliance and environmental information (RoHS, REACH, PEP, EOLI, etc.), go to www.schneider-electric.com/green-premium.

The technical characteristics of the devices described in the present document also appear online. To access the information online:

Step	Action
1	Go to the Schneider Electric home page www.schneider-electric.com .
2	In the Search box type the reference of a product or the name of a product range. <ul style="list-style-type: none">● Do not include blank spaces in the reference or product range.● To get information on grouping similar modules, use asterisks (*).
3	If you entered a reference, go to the Product Datasheets search results and click on the reference that interests you. If you entered the name of a product range, go to the Product Ranges search results and click on the product range that interests you.
4	If more than one reference appears in the Products search results, click on the reference that interests you.
5	Depending on the size of your screen, you may need to scroll down to see the data sheet.
6	To save or print a data sheet as a .pdf file, click Download XXX product datasheet .

The characteristics that are presented in the present document should be the same as those characteristics that appear online. In line with our policy of constant improvement, we may revise content over time to improve clarity and accuracy. If you see a difference between the document and online information, use the online information as your reference.

Related Documents

Title of Documentation	Reference Number
Modicon TMC2 Cartridges - Programming Guide	EIO0000003329 (ENG) EIO0000003330 (FRA) EIO0000003331 (GER) EIO0000003332 (SPA) EIO0000003333 (ITA) EIO0000003334 (CHS) EIO0000003335 (POR) EIO0000003336 (TUR)
Modicon M221 Logic Controller - Hardware Guide	EIO0000003313 (ENG) EIO0000003314 (FRA) EIO0000003315 (GER) EIO0000003316 (SPA) EIO0000003317 (ITA) EIO0000003318 (CHS) EIO0000003319 (POR) EIO0000003320 (TUR)

You can download these technical publications and other technical information from our website at <https://www.schneider-electric.com/en/download>

Product Related Information

 **DANGER**

HAZARD OF ELECTRIC SHOCK, EXPLOSION OR ARC FLASH

- Disconnect all power from all equipment including connected devices prior to removing any covers or doors, or installing or removing any accessories, hardware, cables, or wires except under the specific conditions specified in the appropriate hardware guide for this equipment.
- Always use a properly rated voltage sensing device to confirm the power is off where and when indicated.
- Replace and secure all covers, accessories, hardware, cables, and wires and confirm that a proper ground connection exists before applying power to the unit.
- Use only the specified voltage when operating this equipment and any associated products.

Failure to follow these instructions will result in death or serious injury.

DANGER

POTENTIAL FOR EXPLOSION

- Only use this equipment in non-hazardous locations, or in locations that comply with Class I, Division 2, Groups A, B, C and D.
- Do not substitute components which would impair compliance to Class I, Division 2.
- Do not connect or disconnect equipment unless power has been removed or the location is known to be non-hazardous.
- Do not use the USB port(s), if so equipped, unless the location is known to be non-hazardous.

Failure to follow these instructions will result in death or serious injury.

WARNING

LOSS OF CONTROL

- The designer of any control scheme must consider the potential failure modes of control paths and, for certain critical control functions, provide a means to achieve a safe state during and after a path failure. Examples of critical control functions are emergency stop and overtravel stop, power outage and restart.
- Separate or redundant control paths must be provided for critical control functions.
- System control paths may include communication links. Consideration must be given to the implications of unanticipated transmission delays or failures of the link.
- Observe all accident prevention regulations and local safety guidelines.¹
- Each implementation of this equipment must be individually and thoroughly tested for proper operation before being placed into service.

Failure to follow these instructions can result in death, serious injury, or equipment damage.

¹ For additional information, refer to NEMA ICS 1.1 (latest edition), "Safety Guidelines for the Application, Installation, and Maintenance of Solid State Control" and to NEMA ICS 7.1 (latest edition), "Safety Standards for Construction and Guide for Selection, Installation and Operation of Adjustable-Speed Drive Systems" or their equivalent governing your particular location.

WARNING

UNINTENDED EQUIPMENT OPERATION

- Only use software approved by Schneider Electric for use with this equipment.
- Update your application program every time you change the physical hardware configuration.

Failure to follow these instructions can result in death, serious injury, or equipment damage.

Terminology Derived from Standards

The technical terms, terminology, symbols and the corresponding descriptions in this manual, or that appear in or on the products themselves, are generally derived from the terms or definitions of international standards.

In the area of functional safety systems, drives and general automation, this may include, but is not limited to, terms such as *safety*, *safety function*, *safe state*, *fault*, *fault reset*, *malfunction*, *failure*, *error*, *error message*, *dangerous*, etc.

Among others, these standards include:

Standard	Description
EN 61131-2:2007	Programmable controllers, part 2: Equipment requirements and tests.
ISO 13849-1:2008	Safety of machinery: Safety related parts of control systems. General principles for design.
EN 61496-1:2013	Safety of machinery: Electro-sensitive protective equipment. Part 1: General requirements and tests.
ISO 12100:2010	Safety of machinery - General principles for design - Risk assessment and risk reduction
EN 60204-1:2006	Safety of machinery - Electrical equipment of machines - Part 1: General requirements
EN 1088:2008 ISO 14119:2013	Safety of machinery - Interlocking devices associated with guards - Principles for design and selection
ISO 13850:2006	Safety of machinery - Emergency stop - Principles for design
EN/IEC 62061:2005	Safety of machinery - Functional safety of safety-related electrical, electronic, and electronic programmable control systems
IEC 61508-1:2010	Functional safety of electrical/electronic/programmable electronic safety-related systems: General requirements.
IEC 61508-2:2010	Functional safety of electrical/electronic/programmable electronic safety-related systems: Requirements for electrical/electronic/programmable electronic safety-related systems.
IEC 61508-3:2010	Functional safety of electrical/electronic/programmable electronic safety-related systems: Software requirements.
IEC 61784-3:2008	Digital data communication for measurement and control: Functional safety field buses.
2006/42/EC	Machinery Directive
2014/30/EU	Electromagnetic Compatibility Directive
2014/35/EU	Low Voltage Directive

In addition, terms used in the present document may tangentially be used as they are derived from other standards such as:

Standard	Description
IEC 60034 series	Rotating electrical machines
IEC 61800 series	Adjustable speed electrical power drive systems
IEC 61158 series	Digital data communications for measurement and control – Fieldbus for use in industrial control systems

Finally, the term *zone of operation* may be used in conjunction with the description of specific hazards, and is defined as it is for a *hazard zone* or *danger zone* in the *Machinery Directive (2006/42/EC)* and *ISO 12100:2010*.

NOTE: The aforementioned standards may or may not apply to the specific products cited in the present documentation. For more information concerning the individual standards applicable to the products described herein, see the characteristics tables for those product references.

Part I

TMC2 General Overview

What Is in This Part?

This part contains the following chapters:

Chapter	Chapter Name	Page
1	TMC2 Description	15
2	TMC2 Installation	17

Chapter 1

TMC2 Description

General Description

Introduction

The cartridges are designed to be connected to the Modicon TM221C Logic Controller range.

Cartridges Features

The following table describes the TMC2 cartridges features:

Reference	Description
TMC2AI2 <i>(see page 39)</i>	TMC2 cartridge with 2 analog voltage or current inputs (0...10 V, 0...20 mA, 4...20 mA), 12 bits
TMC2TI2 <i>(see page 45)</i>	TMC2 cartridge with 2 analog temperature inputs (thermocouple, RTD), 14 bits
TMC2AQ2V <i>(see page 51)</i>	TMC2 cartridge with 2 analog voltage outputs (0...10 V), 12 bits
TMC2AQ2C <i>(see page 57)</i>	TMC2 cartridge with 2 analog current outputs (4...20 mA), 12 bits
TMC2SL1 <i>(see page 63)</i>	TMC2 cartridge with 1 serial line (RS232 or RS485)
TMC2HOIS01 <i>(see page 71)</i>	TMC2 application cartridge with 2 analog voltage or current inputs for hoisting load cells
TMC2PACK01 <i>(see page 77)</i>	TMC2 application cartridge with 2 analog voltage or current inputs for packaging
TMC2CONV01 <i>(see page 83)</i>	TMC2 application cartridge with 1 serial line for conveying

Logic Controller Compatibility

NOTE: For more information on cartridge compatibility with specific controllers, refer to your controller-specific hardware guide.

The following table describes the number of TMC2 cartridges that can be installed in a Modicon TM221C Logic Controller:

Reference	Cartridge Slots	Compatible Cartridges Combination	
		TMC2AI2 TMC2TI2 TMC2AQ2V TMC2AQ2C TMC2HOIS01 TMC2PACK01	TMC2SL1 TMC2CONV01
TM221C16R TM221CE16R TM221C16T TM221CE16T TM221C24R TM221CE24R TM221C24T TM221CE24T	1	1	0
		0	1
TM221C40R TM221CE40R TM221C40T TM221CE40T	2 ⁽¹⁾	1	0
		0	1
		1	1
		2	0
(1) Only one serial line cartridge (TMC2SL1, TMC2CONV01) may be added to a logic controller.			

NOTICE

ELECTROSTATIC DISCHARGE

- Verify that empty cartridge slots have their covers in place before applying power to the controller.
- Do not touch the contacts of the cartridge.
- Only handle the cartridge on the housing.
- Take the necessary protective measures against electrostatic discharges.

Failure to follow these instructions can result in equipment damage.

Chapter 2

TMC2 Installation

What Is in This Chapter?

This chapter contains the following sections:

Section	Topic	Page
2.1	TMC2 General Rules for Implementing	18
2.2	TMC2 Installation	21
2.3	TMC2 Electrical Requirements	30

Section 2.1

TMC2 General Rules for Implementing

What Is in This Section?

This section contains the following topics:

Topic	Page
Environmental Characteristics	19
Certifications and Standards	20

Environmental Characteristics

TMC2

TMC2 cartridge environmental characteristics are the same as the Modicon TM221C Logic Controller (*see Modicon M221 Logic Controller, Hardware Guide*).

Certifications and Standards

Introduction

The M221 Logic Controllers are designed to conform to the main national and international standards concerning electronic industrial control devices:

- IEC/EN 61131-2
- UL 508

The M221 Logic Controllers have obtained the following conformity marks:

- CE
- CSA (except for TM221C•••U)
- EAC
- RCM
- UL
- cCSAus Hazardous Location (except for TM221C•••U)

For product compliance and environmental information (RoHS, REACH, PEP, EOLI, etc.), go to www.schneider-electric.com/green-premium.

Section 2.2

TMC2 Installation

What Is in This Section?

This section contains the following topics:

Topic	Page
Installation and Maintenance Requirements	22
TMC2 Installation	24

Installation and Maintenance Requirements

Before Starting

Read and understand this chapter before beginning the installation of your system.

The use and application of the information contained herein require expertise in the design and programming of automated control systems. Only you, the user, machine builder or integrator, can be aware of all the conditions and factors present during installation and setup, operation, and maintenance of the machine or process, and can therefore determine the automation and associated equipment and the related safeties and interlocks which can be effectively and properly used. When selecting automation and control equipment, and any other related equipment or software, for a particular application, you must also consider any applicable local, regional or national standards and/or regulations.

Pay particular attention in conforming to any safety information, different electrical requirements, and normative standards that would apply to your machine or process in the use of this equipment.

Disconnecting Power

All options and modules should be assembled and installed before installing the control system on a mounting rail, onto a mounting plate or in a panel. Remove the control system from its mounting rail, mounting plate or panel before disassembling the equipment.

DANGER

HAZARD OF ELECTRIC SHOCK, EXPLOSION OR ARC FLASH

- Disconnect all power from all equipment including connected devices prior to removing any covers or doors, or installing or removing any accessories, hardware, cables, or wires except under the specific conditions specified in the appropriate hardware guide for this equipment.
- Always use a properly rated voltage sensing device to confirm the power is off where and when indicated.
- Replace and secure all covers, accessories, hardware, cables, and wires and confirm that a proper ground connection exists before applying power to the unit.
- Use only the specified voltage when operating this equipment and any associated products.

Failure to follow these instructions will result in death or serious injury.

Programming Considerations

WARNING

UNINTENDED EQUIPMENT OPERATION

- Only use software approved by Schneider Electric for use with this equipment.
- Update your application program every time you change the physical hardware configuration.

Failure to follow these instructions can result in death, serious injury, or equipment damage.

Operating Environment

In addition to the **Environmental Characteristics**, refer to **Product Related Information** in the beginning of the present document for important information regarding installation in hazardous locations for this specific equipment.

NOTE: For important safety information and the environment characteristics of the TMC2 cartridges, see the M221 Logic Controller Hardware Guide.

Installation Considerations

WARNING

UNINTENDED EQUIPMENT OPERATION

- Use appropriate safety interlocks where personnel and/or equipment hazards exist.
- Install and operate this equipment in an enclosure appropriately rated for its intended environment and secured by a keyed or tooled locking mechanism.
- Use the sensor and actuator power supplies only for supplying power to the sensors or actuators connected to the module.
- Power line and output circuits must be wired and fused in compliance with local and national regulatory requirements for the rated current and voltage of the particular equipment.
- Do not use this equipment in safety-critical machine functions unless the equipment is otherwise designated as functional safety equipment and conforming to applicable regulations and standards.
- Do not disassemble, repair, or modify this equipment.
- Do not connect any wiring to reserved, unused connections, or to connections designated as No Connection (N.C.).

Failure to follow these instructions can result in death, serious injury, or equipment damage.

NOTE: JDYX2 or JDYX8 fuse types are UL-recognized and CSA approved.

TMC2 Installation

Installation Considerations

The TMC2 cartridge is designed to operate within the same temperature range as the controllers, including the controller derating for extended temperature operation, and temperature restrictions associated with the mounting positions. Refer to the controller mounting position and clearance (see *Modicon M221 Logic Controller, Hardware Guide*) for more information.

Installation

DANGER

ELECTRIC SHOCK OR ARC FLASH

- Disconnect all power from all equipment including connected devices prior to removing any covers or doors, or installing or removing any accessories, hardware, cables, or wires.
- Always use a properly rated voltage sensing device to confirm the power is off where and when indicated.
- Use protective gloves when installing or removing the cartridges.
- Replace and secure all covers, accessories, hardware, cables, and wires and confirm that a proper ground connection exists before applying power to the unit.
- Use only the specified voltage when operating this equipment and any associated products.

Failure to follow these instructions will result in death or serious injury.

NOTICE

ELECTROSTATIC DISCHARGE

- Verify that empty cartridge slots have their covers in place before applying power to the controller.
- Do not touch the contacts of the cartridge.
- Only handle the cartridge on the housing.
- Take the necessary protective measures against electrostatic discharges.

Failure to follow these instructions can result in equipment damage.

The following table describes the different steps to install a TMC2 cartridge on the controller:

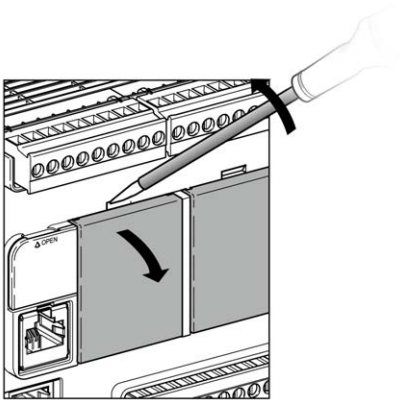
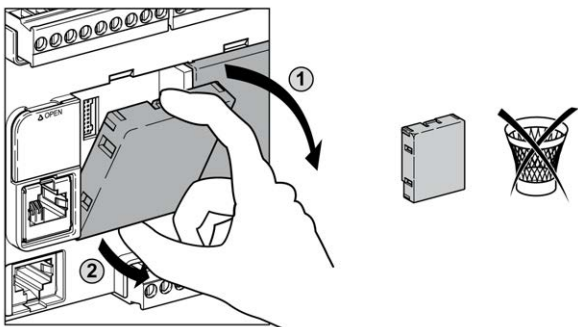
Step	Action
1	Disconnect all power from all equipment prior to removing any covers or installing a cartridge.
2	Remove the cartridge from the packaging.
3	Press the locking clip on the top of the cartridge cover with an insulated screwdriver and pull up the cover gently.
	
4	Remove by hand the cartridge slot cover from the controller. NOTE: Keep the cover to reuse it for the de-installation.
	

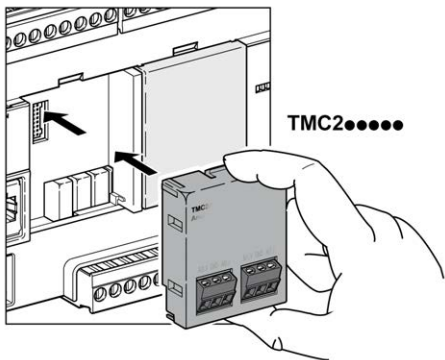
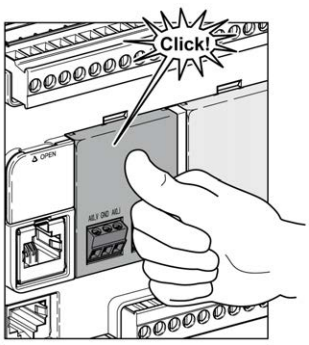
Step	Action
5	<p data-bbox="288 203 727 227">Place the cartridge in the slot on the controller.</p> 
6	<p data-bbox="288 641 699 665">Push the cartridge into the slot until it clicks.</p> 

De-installation  **DANGER****ELECTRIC SHOCK OR ARC FLASH**

- Disconnect all power from all equipment including connected devices prior to removing any covers or doors, or installing or removing any accessories, hardware, cables, or wires.
- Always use a properly rated voltage sensing device to confirm the power is off where and when indicated.
- Use protective gloves when installing or removing the cartridges.
- Replace and secure all covers, accessories, hardware, cables, and wires and confirm that a proper ground connection exists before applying power to the unit.
- Use only the specified voltage when operating this equipment and any associated products.

Failure to follow these instructions will result in death or serious injury.

NOTICE**ELECTROSTATIC DISCHARGE**

- Verify that empty cartridge slots have their covers in place before applying power to the controller.
- Do not touch the contacts of the cartridge.
- Only handle the cartridge on the housing.
- Take the necessary protective measures against electrostatic discharges.

Failure to follow these instructions can result in equipment damage.

The following table describes the different steps to de-install a TMC2 cartridge from the controller:

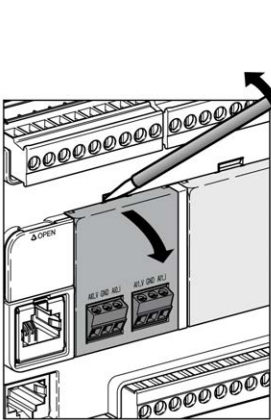
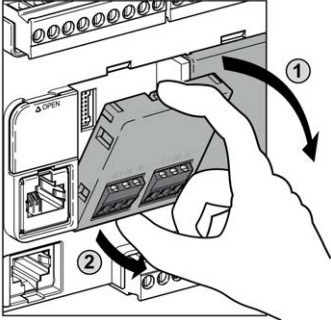
Step	Action
1	Disconnect all power from all equipment, including connected devices, prior to removing a cartridge.
2	<p data-bbox="289 285 1167 337">Press the locking clip on the top of the cartridge with an insulated screwdriver and pull up the cartridge gently.</p> 
3	<p data-bbox="289 816 760 837">Remove by hand the cartridge from the controller.</p> 

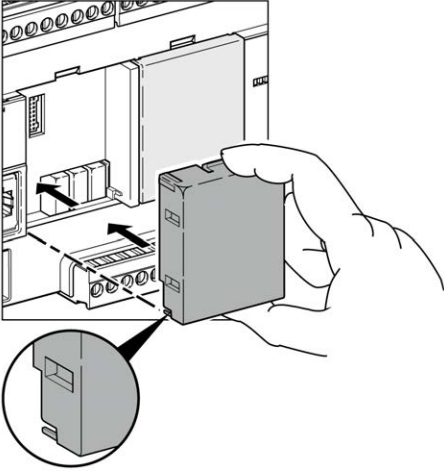
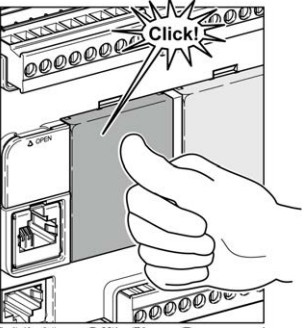
Step	Action
4	<p data-bbox="316 201 857 227">Place the cartridge slot cover in the slot on the controller.</p> 
5	<p data-bbox="316 750 830 776">Push the cartridge slot cover into the slot until it clicks.</p> 

Section 2.3

TMC2 Electrical Requirements

What Is in This Section?

This section contains the following topics:

Topic	Page
Wiring Best Practices	31
Grounding the M221 System	34

Wiring Best Practices

Overview

This section describes the wiring guidelines and associated best practices to be respected when using the M221 Logic Controller system.

DANGER

HAZARD OF ELECTRIC SHOCK, EXPLOSION OR ARC FLASH

- Disconnect all power from all equipment including connected devices prior to removing any covers or doors, or installing or removing any accessories, hardware, cables, or wires except under the specific conditions specified in the appropriate hardware guide for this equipment.
- Always use a properly rated voltage sensing device to confirm the power is off where and when indicated.
- Replace and secure all covers, accessories, hardware, cables, and wires and confirm that a proper ground connection exists before applying power to the unit.
- Use only the specified voltage when operating this equipment and any associated products.

Failure to follow these instructions will result in death or serious injury.

WARNING

LOSS OF CONTROL

- The designer of any control scheme must consider the potential failure modes of control paths and, for certain critical control functions, provide a means to achieve a safe state during and after a path failure. Examples of critical control functions are emergency stop and overtravel stop, power outage and restart.
- Separate or redundant control paths must be provided for critical control functions.
- System control paths may include communication links. Consideration must be given to the implications of unanticipated transmission delays or failures of the link.
- Observe all accident prevention regulations and local safety guidelines.¹
- Each implementation of this equipment must be individually and thoroughly tested for proper operation before being placed into service.

Failure to follow these instructions can result in death, serious injury, or equipment damage.

¹ For additional information, refer to NEMA ICS 1.1 (latest edition), "Safety Guidelines for the Application, Installation, and Maintenance of Solid State Control" and to NEMA ICS 7.1 (latest edition), "Safety Standards for Construction and Guide for Selection, Installation and Operation of Adjustable-Speed Drive Systems" or their equivalent governing your particular location.

Wiring Guidelines

The following rules must be applied when wiring a M221 Logic Controller system:

- I/O and communication wiring must be kept separate from the power wiring. Route these 2 types of wiring in separate cable ducting.
- Verify that the operating conditions and environment are within the specification values.
- Use proper wire sizes to meet voltage and current requirements.
- Use copper conductors (required).
- Use twisted pair, shielded cables for analog, and/or fast I/O.
- Use twisted pair, shielded cables for networks, and fieldbus.

Use shielded, properly grounded cables for all analog and high-speed inputs or outputs and communication connections. If you do not use shielded cable for these connections, electromagnetic interference can cause signal degradation. Degraded signals can cause the controller or attached modules and equipment to perform in an unintended manner.

WARNING

UNINTENDED EQUIPMENT OPERATION

- Use shielded cables for all fast I/O, analog I/O and communication signals.
- Ground cable shields for all analog I/O, fast I/O and communication signals at a single point¹.
- Route communication and I/O cables separately from power cables.

Failure to follow these instructions can result in death, serious injury, or equipment damage.

¹Multipoint grounding is permissible if connections are made to an equipotential ground plane dimensioned to help avoid cable shield damage in the event of power system short-circuit currents.

For more details, refer to Grounding Shielded Cables (*see page 34*).

NOTE: Surface temperatures may exceed 60 °C (140 °F). To conform to IEC 61010 standards, route primary wiring (wires connected to power mains) separately and apart from secondary wiring (extra low voltage wiring coming from intervening power sources). If that is not possible, double insulation is required such as conduit or cable gains.

The cartridge connectors are not removable.

NOTICE







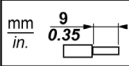

INOPERABLE EQUIPMENT

Do not attempt to remove the connectors from the cartridge.

Failure to follow these instructions can result in equipment damage.

Rules for Non-Removable Screw Terminal Block

The following table shows the cable types and wire sizes for a **3.81 mm (0.15 in.)** pitch non-removable screw terminal block:

							
mm in.	mm ²	AWG	0.14...1.5	0.14...1.5	0.25...1.5	0.25...0.5	2 x 0.5
			25...16	25...16	23...16	23...20	2 x 20
				N•m	0.20		
Ø 2,5 mm (0.1 in.)				lb-in	1.77		

The use of copper conductors is required.

DANGER

LOOSE WIRING CAUSES ELECTRIC SHOCK

Tighten connections in conformance with the torque specifications.

Failure to follow these instructions will result in death or serious injury.

DANGER

FIRE HAZARD

- Use only the correct wire sizes for the current capacity of the I/O channels and power supplies.
- For relay output (2 A) wiring, use conductors of at least 0.5 mm² (AWG 20) with a temperature rating of at least 80 °C (176 °F).
- For common conductors of relay output wiring (7 A), or relay output wiring greater than 2 A, use conductors of at least 1.0 mm² (AWG 16) with a temperature rating of at least 80 °C (176 °F).

Failure to follow these instructions will result in death or serious injury.

Grounding the M221 System

Overview

To help minimize the effects of electromagnetic interference, cables carrying the fast I/O, analog I/O, and field bus communication signals must be shielded.

WARNING

UNINTENDED EQUIPMENT OPERATION

- Use shielded cables for all fast I/O, analog I/O, and communication signals.
- Ground cable shields for all fast I/O, analog I/O, and communication signals at a single point¹.
- Route communications and I/O cables separately from power cables.

Failure to follow these instructions can result in death, serious injury, or equipment damage.

¹Multipoint grounding is permissible if connections are made to an equipotential ground plane dimensioned to help avoid cable shield damage in the event of power system short-circuit currents.

The use of shielded cables requires compliance with the following wiring rules:

- For protective ground connections (PE), metal conduit or ducting can be used for part of the shielding length, provided there is no break in the continuity of the ground connections. For functional ground (FE), the shielding is intended to attenuate electromagnetic interference and the shielding must be continuous for the length of the cable. If the purpose is both functional and protective, as is often the case for communication cables, the cable must have continuous shielding.
- Wherever possible, keep cables carrying one type of signal separate from the cables carrying other types of signals or power.

Protective Ground (PE) on the Backplane

The protective ground (PE) is connected to the conductive backplane by a heavy-duty wire, usually a braided copper cable with the maximum allowable cable section.

Shielded Cables Connections

Cables carrying the fast I/O, analog I/O, and field bus communication signals must be shielded. The shielding must be securely connected to ground. The fast I/O and analog I/O shields may be connected either to the functional ground (FE) or to the protective ground (PE) of your M221 Logic Controller. The field bus communication cable shields must be connected to the protective ground (PE) with a connecting clamp secured to the conductive backplane of your installation.

The shielding of the Modbus cable must be connected to the protective ground (PE).

DANGER

ELECTRIC SHOCK

Make sure that Modbus cables are securely connected to the protective ground (PE).

Failure to follow these instructions will result in death or serious injury.

Protective Ground (PE) Cable Shielding

To ground the shield of a cable through a grounding clamp:

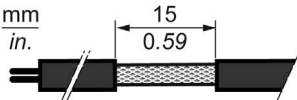
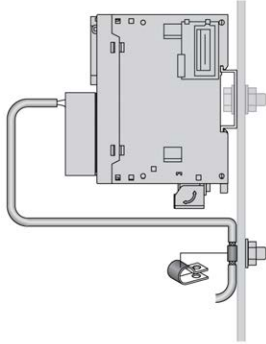
Step	Description	
1	Strip the shielding for a length of 15 mm (0.59 in.)	
2	Attach the cable to the conductive backplane plate by attaching the grounding clamp to the stripped part of the shielding as close as possible to the M221 Logic Controller system base.	

NOTE: The shielding must be clamped securely to the conductive backplane to ensure a good contact.

Functional Ground (FE) Cable Shielding

To connect the shield of a cable through the Grounding Bar:

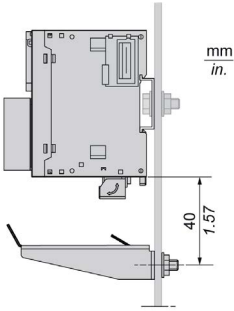
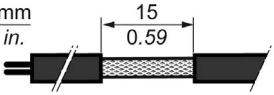
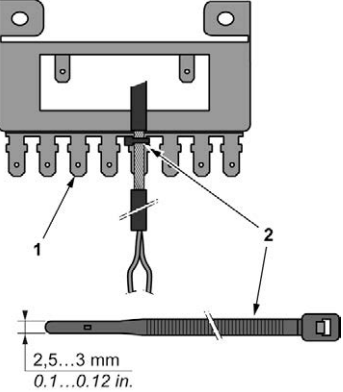
Step	Description	
1	Install the Grounding Bar directly on the conductive backplane below the M221 Logic Controller system as illustrated.	
2	Strip the shielding for a length of 15 mm (0.59 in.).	
3	Tightly clamp on the blade connector (1) using nylon fastener (2) (width 2.5...3 mm (0.1...0.12 in.)) and appropriate tool.	

NOTE: Use the TM2XMTGB Grounding Bar exclusively for Functional Ground (FE) connections.

⚠ WARNING

ACCIDENTAL DISCONNECTION FROM PROTECTIVE GROUND (PE)

- Do not use the TM2XMTGB Grounding Plate to provide a protective ground (PE).
- Use the TM2XMTGB Grounding Plate only to provide a functional ground (FE).

Failure to follow these instructions can result in death, serious injury, or equipment damage.

Part II

TMC2 Standard Cartridges

What Is in This Part?

This part contains the following chapters:

Chapter	Chapter Name	Page
3	TMC2AI2 Analog Voltage, Current Inputs	39
4	TMC2TI2 Analog Temperature Inputs	45
5	TMC2AQ2V Analog Voltage Outputs	51
6	TMC2AQ2C Analog Current Outputs	57
7	TMC2SL1 Serial Line	63

Chapter 3

TMC2AI2 Analog Voltage, Current Inputs

Overview

This chapter describes the TMC2AI2 cartridge, its characteristics, and its connections.

What Is in This Chapter?

This chapter contains the following topics:

Topic	Page
TMC2AI2 Presentation	40
TMC2AI2 Characteristics	41
TMC2AI2 Wiring Diagram	43

TMC2AI2 Presentation

Overview

The following features are integrated into the TMC2AI2 cartridge:

- 2 analog inputs (voltage or current)
- non-removable screw terminal block, 3.81 mm (0.15 in.) pitch

Main Characteristics

Characteristic	Value		
	Signal type	Voltage	Current
Number of input channels	2		
Input range		0...10 Vdc	0...20 mA 4...20 mA
Resolution	12 bits (4096 steps)		
Connection type	3.81 mm (0.15 in.) pitch, non-removable screw terminal block		
Weight	15 g (0.53 oz)		

TMC2AI2 Characteristics

Introduction

This section provides a general description of the TMC2AI2 cartridge characteristics.

⚠ WARNING

UNINTENDED EQUIPMENT OPERATION

Do not exceed any of the rated values specified in the environmental and electrical characteristics tables.

Failure to follow these instructions can result in death, serious injury, or equipment damage.

NOTE: For important safety information and the environment characteristics of the TMC2 cartridges, see the M221 Logic Controller Hardware Guide.

Connectors

The following diagram shows a TMC2AI2 cartridge marking and connectors:

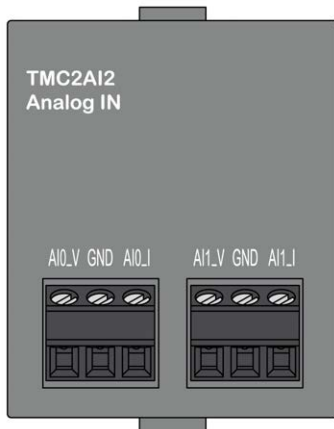

Input Characteristics

The following table describes the cartridge input characteristics:

Characteristics		Value	
	Signal Type	Voltage	Current
Rated input range		0...10 Vdc	0...20 mA 4...20 mA
Input impedance		> 1 M Ω	< 250 Ω
Sample duration time		10 ms per enabled channel	
Input type		single-ended	
Operating mode		self-scan	
Conversion mode		SAR type	
Maximum accuracy at ambient temperature: 25 °C (77 °F)		\pm 0.1 % of full scale	
Temperature drift		\pm 0.02 % of full scale per 1 °C (1.8 °F)	
Repeatability after stabilization time		\pm 0.5 % of full scale	
Non-linearity		\pm 0.01 % of full scale	
Maximum input deviation		\pm 1.0 % of full scale	
Digital resolution		12 bits (4096 steps)	
Input value of LSB		2.44 mV (0...10 Vdc range)	4.88 μ A (0...20 mA range) 3.91 μ A (4...20 mA range)
Data type in application program		scalable from -32768 to 32767	
Input data out of detection range		yes	
Noise resistance	maximum temporary deviation during perturbations	\pm 4.0 % of the full scale maximum when EMC perturbation is applied to the power and I/O wiring	
	cable type and maximum length	twisted-pair shielded < 30 m (98.4 ft)	
	crosstalk (maximum)	1 LSB	
Isolation between inputs and internal logic		not isolated	
Maximum continuous overload allowed (without damage)		13 Vdc	40 mA
Input filter		software filter: 0...10 s (with 0.1 s increment)	

TMC2AI2 Wiring Diagram

Introduction

This cartridge has a non-removable screw terminal block for the connection of the inputs.

Wiring

See Wiring Best Practices (*see page 31*).

Wiring Diagram

The following figure shows an example of the voltage and current input connection:

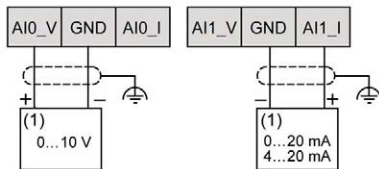

(1): Current/Voltage analog output device

NOTE: Each input can be connected to either a voltage or current input.

Chapter 4

TMC2TI2 Analog Temperature Inputs

Overview

This chapter describes the TMC2TI2 cartridge, its characteristics, and its connections.

What Is in This Chapter?

This chapter contains the following topics:

Topic	Page
TMC2TI2 Presentation	46
TMC2TI2 Characteristics	47
TMC2TI2 Wiring Diagram	50

TMC2TI2 Presentation

Overview

The following features are integrated into the TMC2TI2 cartridge:

- 2 analog temperature inputs (thermocouple or RTD)
- non-removable screw terminal block, 3.81 mm (0.15 in.) pitch

Main Characteristics

Characteristic		Value	
	Signal type	Thermocouple	3 wires RTD
Number of input channels		2	
Input range		type: K, J, R, S, B, E, T, N, C	type: Pt100, Pt1000, Ni100, Ni1000
Resolution		14 bits	
Connection type		3.81 mm (0.15 in.) pitch, non-removable screw terminal block	
Weight		15 g (0.53 oz)	

TMC2TI2 Characteristics

Introduction

This section provides a general description of the TMC2TI2 cartridge characteristics.

⚠ WARNING

UNINTENDED EQUIPMENT OPERATION

Do not exceed any of the rated values specified in the environmental and electrical characteristics tables.

Failure to follow these instructions can result in death, serious injury, or equipment damage.

NOTE: For important safety information and the environment characteristics of the TMC2 cartridges, see the M221 Logic Controller Hardware Guide.

Connectors

The following diagram shows a TMC2TI2 cartridge marking and connectors:

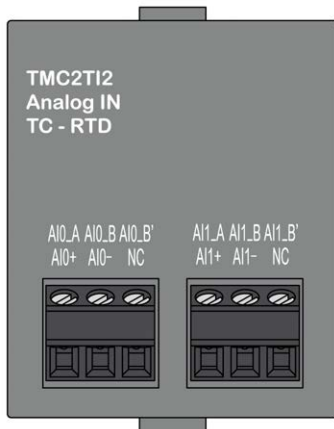

Input Characteristics

The following table describes the cartridge input characteristics:

Characteristics		Value	
	Signal Type	Thermocouple	3 wires RTD
Rated input range		thermocouple type: K: -200...+1300 °C (-328...+2372 °F) J: -200...+1000 °C (-328...+1832 °F) R: 0...+1760 °C (+32...+3200 °F) S: 0...+1760 °C (+32...+3200 °F) B: 0...+1820 °C (+32...+3308 °F) E: -200...+800 °C (-328...+1472 °F) T: -200...+400 °C (-328...+752 °F) N: -200...+1300 °C (-328...+2372 °F) C: 0...+2315 °C (+32...+4199 °F)	RTD type: Pt100: -200...+850 °C (-328...+1562 °F) Pt1000: -200...+600 °C (-328...+1112 °F) Ni100: -60...+180 °C (-76...+356 °F) Ni1000: -60...+180 °C (-76...+356 °F)
Input impedance		> 1 MΩ	
Sample duration time		125 ms per enabled channel	250 ms per enabled channel
Input type		single-ended	
Operating mode		self-scan	
Conversion mode		SAR type	
Maximum accuracy		K, J, E, T, N: ± 0.1 % of full scale at ambient temperature: 25 °C (77 °F) ± 0.4 % of full scale at temperature < 0 °C (32 °F) R, S: ± 6 °C (10.8 °F) of full scale for measured temperature range: 0...200 °C (32...392 °F) B: not specified C: ± 0.1 % of full scale at ambient temperature: 25 °C (77 °F)	± 0.1 % of full scale at ambient temperature: 25 °C (77 °F)
Temperature drift		± 0.02 % of full scale per 1 °C (1.8 °F)	
Repeatability after stabilization time		± 0.5 % of full scale	
Non-linearity		± 0.01 % of full scale	

Characteristics		Value	
	Signal Type	Thermocouple	3 wires RTD
Maximum input deviation		± 1.0 % of full scale	
Digital resolution		thermocouple type: K: 15000 steps J: 12000 steps R: 17600 steps S: 17600 steps B: 18200 steps E: 10000 steps T: 6000 steps N: 15000 steps C: 23150 steps	RTD type: Pt100: 10500 steps Pt1000: 8000 steps Ni100: 2400 steps Ni1000: 2400 steps
Input value of LSB		0.1 °C (0.18 °F)	
Data type in application program		scalable from -32768 to 32767	
Input data out of detection range		yes	
Noise resistance	maximum temporary deviation during perturbations	± 4.0 % of the full scale maximum when EMC perturbation is applied to the power and I/O wiring	
	cable type and maximum length	shielded < 30 m (98.4 ft)	
	crosstalk (maximum)	1 LSB	
Isolation between inputs and internal logic		not isolated	
Maximum continuous overload allowed (without damage)		13 Vdc	40 mA
Input filter		software filter: 0...10 s (with 0.1 s increment)	
Behavior when the temperature sensor is disconnected or broken		input value = upper limit	

TMC2TI2 Wiring Diagram

Introduction

This cartridge has a non-removable screw terminal block for the connection of the inputs.

Wiring

See Wiring Best Practices (*see page 31*).

Wiring Diagram

The following figure shows an example of RTD and thermocouple probe connection:

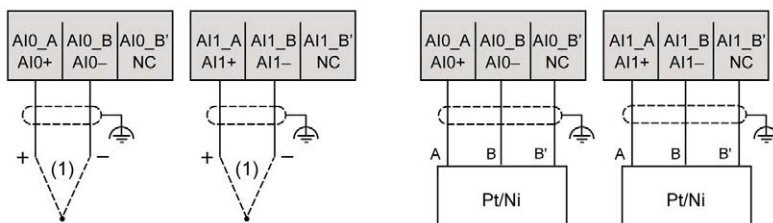

(1): Thermocouple

NOTE: Each input can be connected to either an RTD or thermocouple probe.

⚠ WARNING

UNINTENDED EQUIPMENT OPERATION

Do not connect wires to unused terminals and/or terminals indicated as “No Connection (N.C.)”.

Failure to follow these instructions can result in death, serious injury, or equipment damage.

Chapter 5

TMC2AQ2V Analog Voltage Outputs

Overview

This chapter describes the TMC2AQ2V cartridge, its characteristics, and its connections.

What Is in This Chapter?

This chapter contains the following topics:

Topic	Page
TMC2AQ2V Presentation	52
TMC2AQ2V Characteristics	53
TMC2AQ2V Wiring Diagram	55

TMC2AQ2V Presentation

Overview

The following features are integrated into the TMC2AQ2V cartridge:

- 2 analog voltage outputs
- non-removable screw terminal block, 3.81 mm (0.15 in.) pitch

Main Characteristics

Characteristic		Value
	Signal type	Voltage
Number of output channels		2
Output range		0...10 Vdc
Resolution		12 bits (4096 steps)
Connection type		3.81 mm (0.15 in.) pitch, non-removable screw terminal block
Weight		15 g (0.53 oz)

TMC2AQ2V Characteristics

Introduction

This section provides a general description of the characteristics of the TMC2AQ2V cartridge.

⚠ WARNING

UNINTENDED EQUIPMENT OPERATION

Do not exceed any of the rated values specified in the environmental and electrical characteristics tables.

Failure to follow these instructions can result in death, serious injury, or equipment damage.

NOTE: For important safety information and the environment characteristics of the TMC2 cartridges, see the M221 Logic Controller Hardware Guide.

Connectors

The following diagram shows a TMC2AQ2V cartridge marking and connectors:

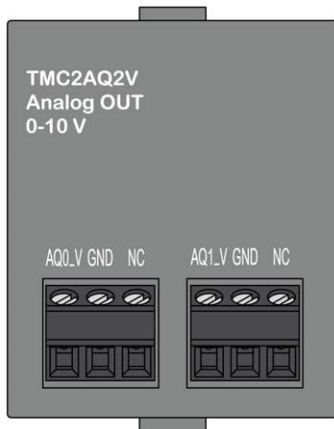

Output Characteristics

The following table describes the cartridge output characteristics:

Characteristics		Value
	Signal Type	Voltage
Rated output range		0...10 Vdc
Load impedance		> 2 K Ω
Application load type		resistive load
Conversion time		20 ms
Total output system transfer time		40 ms
Maximum accuracy at ambient temperature: 25 °C (77 °F)		\pm 0.3 % of full scale
Temperature drift		\pm 0.02 % of full scale per 1 °C (1.8 °F)
Repeatability after stabilization time		\pm 0.4 % of full scale
Non-linearity		\pm 0.01 % of full scale
Overshoot		0 %
Maximum output deviation		\pm 1.0 % of full scale (including ripple)
Digital resolution		12 bits (4096 steps)
Output value of LSB		2.44 mV
Data type in application program		0...4095 scalable from -32768 to 32767
Noise resistance	maximum temporary deviation during perturbations	\pm 4.0 % of the full scale maximum when EMC perturbation is applied to the power and I/O wiring
	cable type and maximum length	twisted-pair shielded
		< 30 m (98.4 ft)
crosstalk (maximum)	1 LSB	
Isolation between outputs and internal logic		not isolated

TMC2AQ2V Wiring Diagram

Introduction

This cartridge has a non-removable screw terminal block for the connection of the outputs.

Wiring

See Wiring Best Practices (*see page 31*).

Wiring Diagram

The following figure shows an example of the voltage output connection:

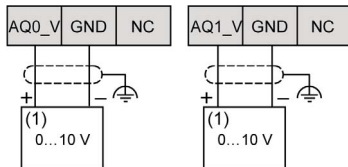

(1): Voltage analog input device

⚠ WARNING

UNINTENDED EQUIPMENT OPERATION

Do not connect wires to unused terminals and/or terminals indicated as “No Connection (N.C.)”.

Failure to follow these instructions can result in death, serious injury, or equipment damage.

Chapter 6

TMC2AQ2C Analog Current Outputs

Overview

This chapter describes the TMC2AQ2C cartridge, its characteristics, and its connections.

What Is in This Chapter?

This chapter contains the following topics:

Topic	Page
TMC2AQ2C Presentation	58
TMC2AQ2C Characteristics	59
TMC2AQ2C Wiring Diagram	61

TMC2AQ2C Presentation

Overview

The following features are integrated into the TMC2AQ2C cartridge:

- 2 analog current outputs
- non-removable screw terminal block, 3.81 mm (0.15 in.) pitch

Main Characteristics

Characteristic		Value
	Signal type	Current
Number of output channels		2
Output range		4...20 mA
Resolution		12 bits (4096 steps)
Connection type		3.81 mm (0.15 in.) pitch, non-removable screw terminal block
Weight		15 g (0.53 oz)

TMC2AQ2C Characteristics

Introduction

This section provides a general description of the TMC2AQ2C cartridge characteristics.

⚠ WARNING

UNINTENDED EQUIPMENT OPERATION

Do not exceed any of the rated values specified in the environmental and electrical characteristics tables.

Failure to follow these instructions can result in death, serious injury, or equipment damage.

NOTE: For important safety information and the environment characteristics of the TMC2 cartridges, see the M221 Logic Controller Hardware Guide.

Connectors

The following diagram shows a TMC2AQ2C cartridge marking and connectors:



Output Characteristics

The following table describes the cartridge output characteristics:

Characteristics		Value
	Signal Type	Current
Rated output range		4...20 mA
Load impedance		< 500 Ω
Application load type		resistive load
Conversion time		20 ms
Total output system transfer time		40 ms
Maximum accuracy at ambient temperature: 25 °C (77 °F)		± 0.3 % of full scale
Temperature drift		± 0.02 % of full scale per 1 °C (1.8 °F)
Repeatability after stabilization time		± 0.4 % of full scale
Non-linearity		± 0.01 % of full scale
Overshoot		0 %
Maximum output deviation		± 1.0 % of full scale (including ripple)
Digital resolution		12 bits (4096 steps)
Output value of LSB		3.91 μ A
Data type in application program		0...4095 scalable from -32768 to 32767
Noise resistance	maximum temporary deviation during perturbations	± 4.0 % of the full scale maximum when EMC perturbation is applied to the power and I/O wiring
	cable type and maximum length	twisted-pair shielded
		< 30 m (98.4 ft)
crosstalk (maximum)	1 LSB	
Isolation between outputs and internal logic		not isolated

TMC2AQ2C Wiring Diagram

Introduction

This cartridge has a non-removable screw terminal block for the connection of the outputs.

Wiring

See Wiring Best Practices (*see page 31*).

Wiring Diagram

The following figure shows an example of the current output connection:

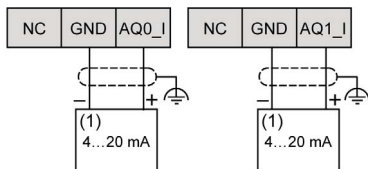

(1): Current analog input device

⚠ WARNING

UNINTENDED EQUIPMENT OPERATION

Do not connect wires to unused terminals and/or terminals indicated as “No Connection (N.C.)”.

Failure to follow these instructions can result in death, serious injury, or equipment damage.

Chapter 7

TMC2SL1 Serial Line

Overview

This chapter describes the TMC2SL1 cartridge, its characteristics, and its connections.

What Is in This Chapter?

This chapter contains the following topics:

Topic	Page
TMC2SL1 Presentation	64
TMC2SL1 Characteristics	65
TMC2SL1 Wiring Diagram	67

TMC2SL1 Presentation

Overview

The following features are integrated into the TMC2SL1 cartridge:

- 1 serial line (RS232 or RS485)
- non-removable screw terminal block, 3.81 mm (0.15 in.) pitch

Main Characteristics

Characteristic	Value	
	Serial line RS232	Serial line RS485
Number of channels	1	
Connection type	3.81 mm (0.15 in.) pitch, non-removable screw terminal block	
Weight	15 g (0.53 oz)	

TMC2SL1 Characteristics

Introduction

This section provides a general description of the TMC2SL1 cartridge characteristics.

⚠ WARNING

UNINTENDED EQUIPMENT OPERATION

Do not exceed any of the rated values specified in the environmental and electrical characteristics tables.

Failure to follow these instructions can result in death, serious injury, or equipment damage.

NOTE: For important safety information and the environment characteristics of the TMC2 cartridges, see the M221 Logic Controller Hardware Guide.

Connectors

The following diagram shows a TMC2SL1 cartridge marking and connectors:

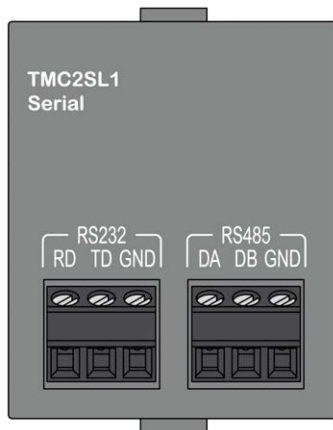

Serial Line Characteristics

The following table describes the cartridge serial line characteristics:

Characteristics		Value	
Software configurable standard		RS232	RS485
Baudrate		1200...115200 bps	
Wires		Rx, Tx, common	DA, DB, common
Protocol selection		software programmable	
Line polarization		–	software programmable
Line end adapter in the cartridge		no	
cable	type	shielded	
	length	< 3 m (9.8 ft)	< 15 m (49.2 ft)
Isolation between lines and internal logic		not isolated	

TMC2SL1 Wiring Diagram

Introduction

This cartridge has a non-removable screw terminal block for the connection of the serial line wires.

Wiring

See Wiring Best Practices (*see page 31*).

Wiring Diagram

The following figure shows an example of RS232 serial line connection:

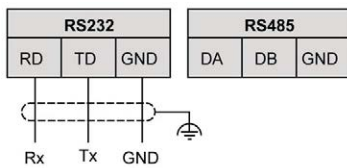

The following figure shows an example of RS485 serial line connection:

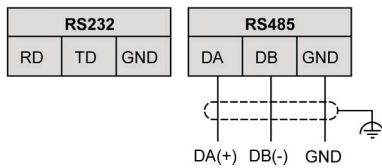

NOTE: Only 1 serial line (RS232 or RS485) can be connected to the cartridge.

NOTE: Only 1 TMC2SL1 cartridge is managed per logic controller.

Part III

TMC2 Application Cartridges

What Is in This Part?

This part contains the following chapters:

Chapter	Chapter Name	Page
8	TMC2HOIS01 Hoisting	71
9	TMC2PACK01 Packaging	77
10	TMC2CONV01 Conveying	83

Chapter 8

TMC2HOIS01 Hoisting

Overview

This chapter describes the TMC2HOIS01 cartridge, its characteristics, and its connections.

What Is in This Chapter?

This chapter contains the following topics:

Topic	Page
TMC2HOIS01 Presentation	72
TMC2HOIS01 Characteristics	73
TMC2HOIS01 Wiring Diagram	75

TMC2HOIS01 Presentation

Overview

The following features are integrated into the TMC2HOIS01 cartridge:

- 2 analog inputs (voltage or current) for hoisting load cells
- non-removable screw terminal block, 3.81 mm (0.15 in.) pitch

Main Characteristics

Characteristic	Value		
	Signal type	Voltage	Current
Number of input channels	2		
Input range	0...10 Vdc		0...20 mA 4...20 mA
Resolution	12 bits (4096 steps)		
Connection type	3.81 mm (0.15 in.) pitch, non-removable screw terminal block		
Weight	15 g (0.53 oz)		

TMC2HOIS01 Characteristics

Introduction

This section provides a general description of the TMC2HOIS01 cartridge characteristics.

⚠ WARNING

UNINTENDED EQUIPMENT OPERATION

Do not exceed any of the rated values specified in the environmental and electrical characteristics tables.

Failure to follow these instructions can result in death, serious injury, or equipment damage.

NOTE: For important safety information and the environment characteristics of the TMC2 cartridges, see the M221 Logic Controller Hardware Guide.

Connectors

The following diagram shows a TMC2HOIS01 cartridge marking and connectors:

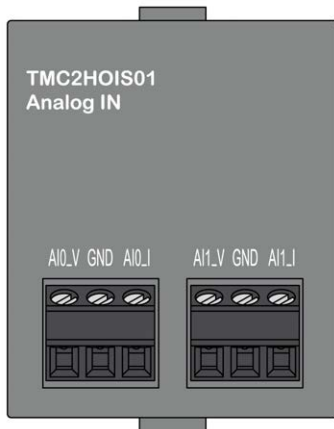

Input Characteristics

The following table describes the cartridge input characteristics:

Characteristics		Value	
	Signal Type	Voltage	Current
Rated input range		0...10 Vdc	0...20 mA 4...20 mA
Input impedance		> 1 M Ω	< 250 Ω
Sample duration time		10 ms per enabled channel	
Input type		single-ended	
Operating mode		self-scan	
Conversion mode		SAR type	
Maximum accuracy at ambient temperature: 25 °C (77 °F)		\pm 0.1 % of full scale	
Temperature drift		\pm 0.02 % of full scale per 1 °C (1.8 °F)	
Repeatability after stabilization time		\pm 0.5 % of full scale	
Non-linearity		\pm 0.01 % of full scale	
Maximum input deviation		\pm 1.0 % of full scale	
Digital resolution		12 bits (4096 steps)	
Input value of LSB		2.44 mV (0...10 Vdc range)	4.88 μ A (0...20 mA range) 3.91 μ A (4...20 mA range)
Data type in application program		scalable from -32768 to 32767	
Input data out of detection range		yes	
Noise resistance	maximum temporary deviation during perturbations	\pm 4.0 % of the full scale maximum when EMC perturbation is applied to the power and I/O wiring	
	cable type and maximum length	twisted-pair shielded < 30 m (98.4 ft)	
	crosstalk (maximum)	1 LSB	
Isolation between inputs and internal logic		not isolated	
Maximum continuous overload allowed (without damage)		13 Vdc	40 mA
Input filter		software filter: 0...10 s (with 0.1 s increment)	

TMC2HOIS01 Wiring Diagram

Introduction

This cartridge has a non-removable screw terminal block for the connection of the inputs.

Wiring

See Wiring Best Practices (*see page 31*).

Wiring Diagram

The following figure shows an example of the voltage and current input connection:

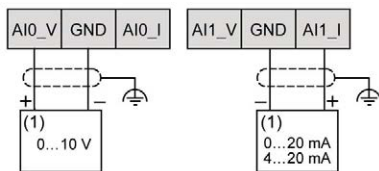

(1): Current/Voltage analog output device

NOTE: Each input can be connected to either a voltage or current input.

Chapter 9

TMC2PACK01 Packaging

Overview

This chapter describes the TMC2PACK01 cartridge, its characteristics, and its connections.

What Is in This Chapter?

This chapter contains the following topics:

Topic	Page
TMC2PACK01 Presentation	78
TMC2PACK01 Characteristics	79
TMC2PACK01 Wiring Diagram	81

TMC2PACK01 Presentation

Overview

The following features are integrated into the TMC2PACK01 cartridge:

- 2 analog inputs (voltage or current) for packaging
- non-removable screw terminal block, 3.81 mm (0.15 in.) pitch

Main Characteristics

Characteristic	Value	
	Signal type	Voltage
Number of input channels	2	
Input range	0...10 Vdc	0...20 mA 4...20 mA
Resolution	12 bits (4096 steps)	
Connection type	3.81 mm (0.15 in.) pitch, non-removable screw terminal block	
Weight	15 g (0.53 oz)	

TMC2PACK01 Characteristics

Introduction

This section provides a general description of the TMC2PACK01 cartridge characteristics.

⚠ WARNING

UNINTENDED EQUIPMENT OPERATION

Do not exceed any of the rated values specified in the environmental and electrical characteristics tables.

Failure to follow these instructions can result in death, serious injury, or equipment damage.

NOTE: For important safety information and the environment characteristics of the TMC2 cartridges, see the M221 Logic Controller Hardware Guide.

Connectors

The following diagram shows a TMC2PACK01 cartridge marking and connectors:



Input Characteristics

The following table describes the cartridge input characteristics:

Characteristics		Value	
	Signal Type	Voltage	Current
Rated input range		0...10 Vdc	0...20 mA 4...20 mA
Input impedance		> 1 M Ω	< 250 Ω
Sample duration time		10 ms per enabled channel	
Input type		single-ended	
Operating mode		self-scan	
Conversion mode		SAR type	
Maximum accuracy at ambient temperature: 25 °C (77 °F)		\pm 0.1 % of full scale	
Temperature drift		\pm 0.02 % of full scale per 1 °C (1.8 °F)	
Repeatability after stabilization time		\pm 0.5 % of full scale	
Non-linearity		\pm 0.01 % of full scale	
Maximum input deviation		\pm 1.0 % of full scale	
Digital resolution		12 bits (4096 steps)	
Input value of LSB		2.44 mV (0...10 Vdc range)	4.88 μ A (0...20 mA range) 3.91 μ A (4...20 mA range)
Data type in application program		scalable from -32768 to 32767	
Input data out of detection range		yes	
Noise resistance	maximum temporary deviation during perturbations	\pm 4.0 % of the full scale maximum when EMC perturbation is applied to the power and I/O wiring	
	cable type and maximum length	twisted-pair shielded < 30 m (98.4 ft)	
	crosstalk (maximum)	1 LSB	
Isolation between inputs and internal logic		not isolated	
Maximum continuous overload allowed (without damage)		13 Vdc	40 mA
Input filter		software filter: 0...10 s (with 0.1 s increment)	

TMC2PACK01 Wiring Diagram

Introduction

This cartridge has a non-removable screw terminal block for the connection of the inputs.

Wiring

See Wiring Best Practices (*see page 31*).

Wiring Diagram

The following figure shows an example of the voltage and current input connection:

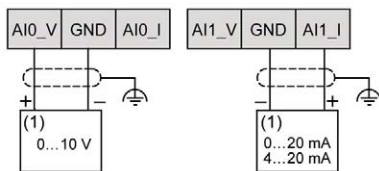

(1): Current/Voltage analog output device

NOTE: Each input can be connected to either a voltage or current input.

Chapter 10

TMC2CONV01 Conveying

Overview

This chapter describes the TMC2CONV01 cartridge, its characteristics, and its connections.

What Is in This Chapter?

This chapter contains the following topics:

Topic	Page
TMC2CONV01 Presentation	84
TMC2CONV01 Characteristics	85
TMC2CONV01 Wiring Diagram	87

TMC2CONV01 Presentation

Overview

The following features are integrated into the TMC2CONV01 cartridge:

- 1 serial line (RS232 or RS485) for conveying
- non-removable screw terminal block, 3.81 mm (0.15 in.) pitch

Main Characteristics

Characteristic	Value	
	Serial line RS232	Serial line RS485
Number of channels	1	
Connection type	3.81 mm (0.15 in.) pitch, non-removable screw terminal block	
Weight	15 g (0.53 oz)	

TMC2CONV01 Characteristics

Introduction

This section provides a general description of the TMC2CONV01 cartridge characteristics.

⚠ WARNING

UNINTENDED EQUIPMENT OPERATION

Do not exceed any of the rated values specified in the environmental and electrical characteristics tables.

Failure to follow these instructions can result in death, serious injury, or equipment damage.

NOTE: For important safety information and the environment characteristics of the TMC2 cartridges, see the M221 Logic Controller Hardware Guide.

Connectors

The following diagram shows a TMC2CONV01 cartridge marking and connectors:

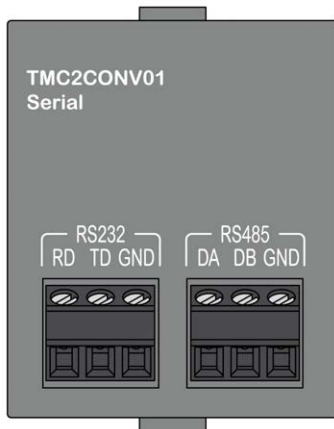

Serial Line Characteristics

The following table describes the cartridge serial line characteristics:

Characteristics		Value	
Software configurable standard		RS232	RS485
Baudrate		1200...115200 bps	
Wires		Rx, Tx, common	DA, DB, common
Protocol selection		software programmable	
Line polarization		–	software programmable
Line end adapter in the cartridge		no	
cable	type	shielded	
	length	< 3 m (9.8 ft)	< 15 m (49.2 ft)
Isolation between lines and internal logic		not isolated	

TMC2CONV01 Wiring Diagram

Introduction

This cartridge has a non-removable screw terminal block for the connection of the serial line wires.

Wiring

See Wiring Best Practices (*see page 31*).

Wiring Diagram

The following figure shows an example of RS232 serial line connection:

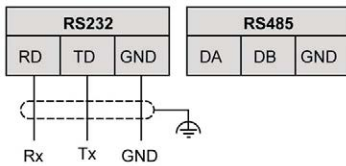

The following figure shows an example of RS485 serial line connection:

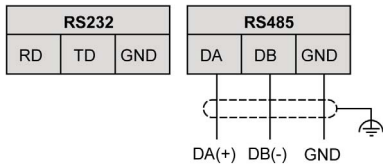

NOTE: Only 1 serial line (RS232 or RS485) can be connected to the cartridge.

NOTE: Only 1 TMC2CONV01 cartridge is managed per logic controller.

Glossary



M

Modbus

The protocol that allows communications between many devices connected to the same network.

P

PE

(Protective Earth) A common grounding connection to help avoid the hazard of electric shock by keeping any exposed conductive surface of a device at earth potential. To avoid possible voltage drop, no current is allowed to flow in this conductor (also referred to as *protective ground* in North America or as an equipment grounding conductor in the US national electrical code).



C

cartridge

- compatibility, *16*
- description, *15*
- features, *15*
- TMC2, *37, 69*
- TMC2AI2, *39*
- TMC2AQ2C, *57*
- TMC2AQ2V, *51*
- TMC2CONV01, *83*
- TMC2HOIS01, *71*
- TMC2PACK01, *77*
- TMC2SL1, *63*
- TMC2TI2, *45*

certifications and standards, *20*

compatibility

- cartridge, *16*

D

description

- cartridge, *15*

E

environment, *19*

F

features

- cartridge, *15*

G

Grounding, *34*

R

RS232, *63*

RS485, *63*

T

TMC2

- cartridge, *37, 69*

TMC2AI2

- cartridge, *39*

TMC2AQ2C

- cartridge, *57*

TMC2AQ2V

- cartridge, *51*

TMC2CONV01

- cartridge, *83*

TMC2HOIS01

- cartridge, *71*

TMC2PACK01

- cartridge, *77*

TMC2SL1

- cartridge, *63*

TMC2TI2

- cartridge, *45*

W

wiring, *31*

