

# Spitfire® LED

## Signature Spitfire LED weatherproof remote lamp head and power supply unit Nexus®



### Range

Signature range

### Product group

Spitfire® LED

### Features

- 3 year warranty
- Superior photometric classification
- LED technology 100,000 hours lamp life
- Single or dual LED option
- Polycarbonate IP67 weatherproof enclosure
- Lamp head -30°C operation
- High temperature NiCad batteries
- Nexus® monitored, either cabled or wireless
- Lamp head used in combination with remote power supply; lamp head mounted inside the freezer or coolroom and remote power supply mounted outside
- Surface mount
- Supplied with 1.5m interconnect cable, suitable for 25mm conduit

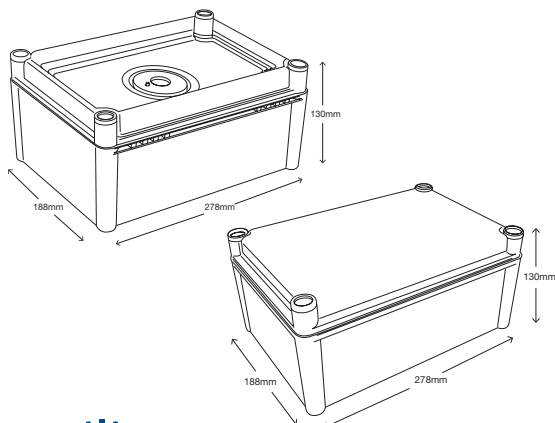

### Nexus products

Catalogue no.	Description
SFBWP1LEDLHREM	LED Spitfire single weatherproof surface mount remote lamp head
SFBWP2LEDLHREM	LED Spitfire dual weatherproof surface mount remote lamp head
SFBWPNXLEDPSU	LED Spitfire weatherproof surface mount Nexus LX power supply unit
SFBWPNRFLLEDPSU	LED Spitfire weatherproof surface mount Nexus RF power supply unit

### Spare parts

Catalogue no.	Description
03-01220	Battery 5 cell NiCad 6.0V 1.8Ah

### Dimensions

Length	Width	Height
278mm	188mm	130mm

### Weight

Model	Weight
Lamp head	1.8kg
Power supply unit	2.0kg

### Construction

Part	Construction
Lamp head	White polycarbonate
Weatherproof enclosure	Polycarbonate

### Light source

Model	Light source
Single LED	2W
Dual LED	3W

### Power consumption

Model	Power consumption
Nexus LX/RF	5.1W

### Photometrics

Model	Class	Classification
Single LED	C0	D40
	C90	D40
Dual LED	C0	D50
	C90	D50

Note: Designed to comply with AS2293 and meet relevant Australian EMC standards

For more information please contact:

**ABB Australia Pty Limited**

Phone: 1300 666 595

Fax: 1300 666 594

E-mail: AU-ABB-Stanilite@abb.com

**[www.stanilite.com.au](http://www.stanilite.com.au)**

**Note:** We reserve the right to make technical changes or modify the contents of this document without prior notice. With regard to purchase orders, the agreed particulars shall prevail. ABB does not accept any responsibility whatsoever for potential errors or possible lack of information in this document.

We reserve all rights in this document and in the subject matter and illustrations contained therein. Any reproduction, disclosure to third parties or utilisation of its contents – in whole or in parts – is forbidden without prior written consent of ABB.

Copyright © 2016 ABB  
All rights reserved