



A.A.G. STUCCHI

Essential for lighting



A.A.G. STUCCHI s.r.l. u.s.
Via IV Novembre 30/32,
23854 Olginate (LC) Italy
Ph. +39 0341 653111
Fax +39 0341 653250
www.aagstucchi.it
info@aagstucchi.it

226

226/TF 226/TF-FEP

226/DS 226/DT

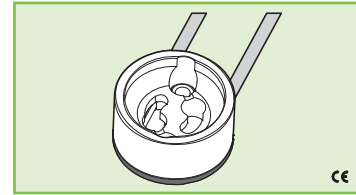

PORTALAMPADE PER LAMPADE AD INCANDESCENZA TUNGSTENO ALOGENE A TENSIONE DI RETE LAMP HOLDERS FOR MAIN VOLTAGE TUNGSTEN HALOGEN INCANDESCENT LAMPS

Dati tecnici

Technical data

- Attacco lampada - Lamp cap	GU10
- Corrente e tensione nominale - Rated current and voltage	2A-250V
- Temperatura massima di funzionamento (IEC) - Maximum operating temperature (IEC)	T250
- Grado di protezione - Protection index	IP20
- Categoria di sovratensione - Impulse withstand category	II

Caratteristiche

Characteristics

- Corpo in steatite
- Steatite front part
- Base in PPS (T1= 240 °C)
- PPS body (T1= 240 °C)
- Contatti in nichel
- Nickel contacts

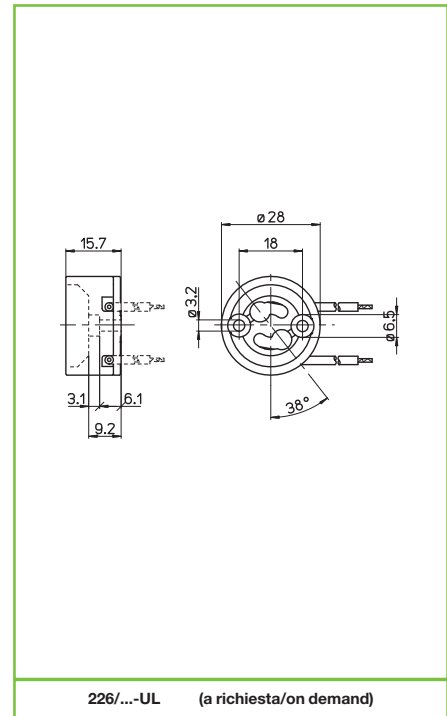

fissaggio con vite screw fixing	conduttore saldato elettricamente al contatto conductor electrically spot-welded to the contact	sezione conduttore flessibile con fascetta section of the flexible conductor with ferrule	sezione conduttore flessibile con fascetta section of the flexible conductor with ferrule
sezione conduttore flessibile con fascetta section of the flexible conductor with ferrule	sezione conduttore flessibile con fascetta section of the flexible conductor with ferrule	sezione conduttore flessibile con fascetta section of the flexible conductor with ferrule	lunghezza cavetto flessibile flexible wire length

Marchi di qualità

Quality marks

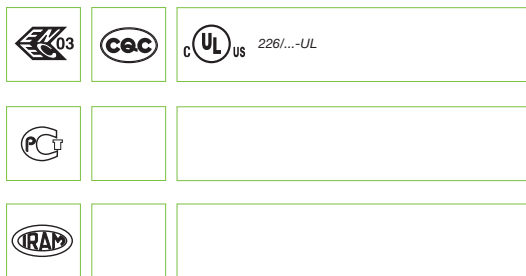

Direttive Europee

European directives

Conforme "RoHS"
"RoHS" compliant
Non soggetto alla "RAEE"
Not subject to "WEEE"

Pesi e confezioni

Weights and packaging

Art. codice prodotti product references	g peso netto net weight	 pezzi per sacco pieces per bag	 pezzi per scatola pieces per box
226	18,8		200
226/TF	18,1		200
226/TF-FEP	17,8		200
226/DS	21,4		200
226/DT	18,4		200

Note

Notes