

## HNS420TM OWNER'S MANUAL



Scan our QR code with your phone to go directly to our website for technical information



**2-WIRE NOT SUITABLE FOR FANS, MOTORS OR IRON CORE BALLASTS**

### 1. FEATURES

- Includes both Timer and Boost functions.
- Amber LED indicates device status.
- User programmable time-out period.
- Programmable in 1 hour increments from 1 to 24 hours.
- When ON - Quick Tap turns power OFF.
- Time-out expiry warning given within the last 10 minutes of operation.
- Retains settings even after loss of mains power.
- Configurable power up ON or OFF after loss of mains power.
- Compatible with HPM and Clipsal Style wall plates.
- Multi-way Switching compatible with 240V normally open momentary switches.
- Time out set to 1 hour out of box.

### 2. OPERATING CONDITIONS

- Operating Voltage: 230 – 240V a.c. 50Hz
- Operating Temperature: 0 to +50 °C
- Certification Standard: CISPR15, AS/NZS 3100, AS/NZS 60669.2.1
- Maximum Load: 400VA
- Minimum Load: 10VA
- Maximum Current capacity: 1.7A
- Terminals: Screw Terminals suit 0.5mm<sup>2</sup> to 1.5mm<sup>2</sup> stranded (bootlace terminal recommended)

Note: Operation at temperature, voltage or load outside of the specifications may cause permanent damage to the unit.

### 3. LOAD COMPATIBILITY

LOAD TYPE	COMPATIBILITY
LED Lamps <sup>(1)</sup>	400VA
Incandescent / 240V Halogen / Dichroic Lamps	400VA
Low Voltage Halogen / Dichroic Lighting with Iron-Core Transformers	Not Compatible
Low Voltage Halogen / Dichroic Lighting with Electronic Transformers <sup>(1)</sup>	400VA
Dimmable Compact Fluorescent Lamps <sup>(1)</sup>	400VA
Motors / Fans / Contactors / Relays / Transformers	Not Compatible
Fluorescent Tube with Electronic Ballast <sup>(1)</sup> or Iron Core Ballast	Not Compatible

<sup>(1)</sup> Refer to lamp manufacturer's guidelines. Lamps must be compatible with electronic switches

**Note: This manual was correct at the time of manufacture. For the latest version of the manual and any technical or safety updates refer to the website:- [www.sclick.com.au](http://www.sclick.com.au) or scan the QR code with a mobile phone.**

## 4. WIRING INSTRUCTIONS

**WARNING:** The HNS420TM is to be installed as part of a fixed wire electrical installation. By law such installations must be made by an electrical contractor or similarly qualified person.

**NOTE:** A readily available disconnect device, such as a type C 16A circuit breaker shall be incorporated external to the product.

### 4.1 WIRING

- Disconnect power at the circuit breaker before any electrical work.
- Install the HNS420TM as per the wiring diagram in figure below.

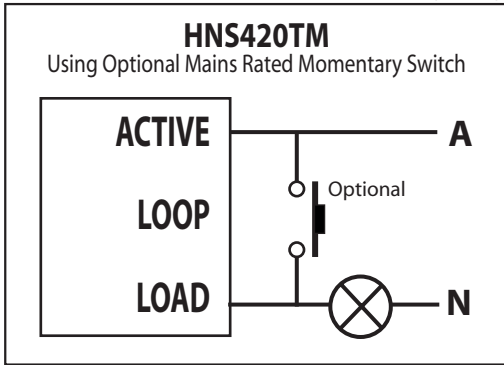

Figure 1

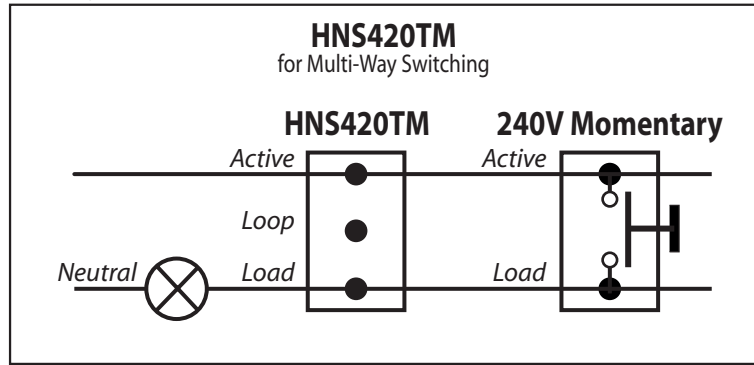

Figure 2

- Clip the button on to the HNS420TM. Ensure that the button is oriented so that the LED light pipe is aligned with the hole in the button, before attaching it to the wall plate.
- Affix Instruction Sticker behind wall plate.
- Reconnect power at the circuit breaker and affix Solid State Device Warning Sticker at switchboard.

**Note:** The HNS420TM is designed for indoor use. It is not rated for outdoor installation. If the unit is loose in the plate, the wall plate should be replaced. The wire strip length is 6.5mm.

### 4.2 MULTI-WAY SWITCHING

- The HNS420TM is multi-way switching capable by using mains rated momentary action switches wired across the Active and Load connections. Suitable switches include the HPM EM870K or Clipsal 681M20P.
- There is no limit to the number of remote switches provided the total remote wire length does not exceed 50 metres.
- Holding a remote button for over 1 second will cause the timer to restart.
- The lights will flash momentarily when turned off with a remote button.
- The HNS420TM cannot be programmed using a remote button.

### 4.3 DERATING

- In high ambient temperatures, the maximum load rating is reduced according to the table below.

AMBIENT TEMPERATURE	MAXIMUM LOAD
25°C	100%
30°C	90%
35°C	80%
40°C	70%
45°C	60%
50°C	50%

## 5. OPERATING INSTRUCTIONS

When the power is OFF the power can be turned on with the HNS420TM in either Timer mode or Boost mode.

### 5.1 TIMER

- A quick tap of the button (local or remote) will turn the power ON.
- The LED will flash indicating the number of hours the power will be ON before power is turned OFF.
- The LED will blink every 5 seconds to indicate that timer mode is in operation.
- During the last 10 seconds of operation the LED will flash indicating imminent time out.
- During operation, the button (local or remote) may be given a quick tap to cancel the timer and turn the power OFF.

### 5.2 BOOST MODE

- Press and hold the button for 2 seconds until the LED indicator turns OFF.
- Release the button.
- Power will turn ON for double the normal time, up to a maximum of 24 hours.
- The LED will flash indicating the number of hours the power will be ON before power is turned OFF.
- The LED will blink twice every 5 seconds to indicate that Boost mode is in operation.

### 5.3 PROGRAMMING TIMER DURATION

- Programming mode may be entered at any time by pushing and holding the button down for 10 seconds. The LED will flash quickly to indicate that programming mode has been entered.
- To program, press the button between 1 and 24 times according to the desired delay in hours. For example, 10 presses will result in a delay of 10 hours. More than 24 presses will result in a delay time of 24 hours being stored.
- Programming mode expires 10 seconds after the last button press. At this time the new delay is stored in memory. If no button presses were detected the delay time will be unchanged.
- It is only possible to enter programming mode from the local button.

**NOTE:** While adjusting the timer duration the operation modes cannot be changed.

## 6. OPERATION MODES

MODE	DESCRIPTION	FACTORY SETTINGS
1. Power Up ON	Unit powers up in the ON state	ON

### 6.1 POWER UP ON

- The timer can be set to power up ON or power up OFF after the application of mains power. The default setting is ON. The OFF setting is useful for applications that have a master power switch or intermittent power supply.

### 6.2 CHANGING OPERATION MODES

- Hold the button down for 10 seconds until the LED indicator starts flashing. Release the button.
- Hold the button down for 2 seconds until the LED indicator turns OFF.
- Release the button - the LED indicator will start flashing again.
- Press the button once to toggle the desired Operation Mode - see table above.
- When the LED indicator stops flashing the operation mode has been toggled.

**NOTE:** The operating mode cannot be changed while adjusting the timer duration

*To change the Power Up ON Setting*

- Hold the button down for 10 seconds until the LED indicator starts flashing. Release the button.
- Hold the button down for 2 seconds until the LED indicator turns OFF.
- Release the button - the LED indicator will start flashing again.
- Press the button once.
- When the LED indicator stops flashing the setting is now toggled.

*To Reset HNS420TM to factory settings*

- i. Hold the button down for 10 seconds until the LED indicator starts flashing.
- ii. Release the button.
- iii. Hold the button down for 10 seconds again until the LED indicator starts flashing again.
- iv. Release the button.
- v. The timer will turn OFF - the timer is now reset to factory settings.

## 7. IMPORTANT SAFETY WARNINGS

### 7.1 LOAD REPLACEMENT

- It should be assumed that even when OFF, mains voltage will still be present at the load fitting. Mains power should therefore be disconnected at the circuit breaker before replacing loads.

### 7.2 INSTALLATION

- The HNS420TM is to be installed as part of a fixed wire electrical installation. By law, such installations must be made by an electrical contractor or similarly qualified person. Avoid excessive force on remote input wire or terminal block during installation.

### 7.3 LOW READING DURING INSULATION BREAKDOWN TEST

- The HNS420TM is a solid state device. Therefore a low reading may be observed when conducting insulation breakdown testing on the circuit.

### 7.4 CLEANING

- Clean only with a damp cloth. Do not use abrasives or chemicals.

## 8. WARRANTY AND DISCLAIMER

Legend Corporation Limited warrants the product against manufacturing and material defect from the date of invoice to the initial purchaser for a period of 12 months. During the warranty period Legend Corporation Limited will replace products that prove to be defective where the product has been correctly installed and maintained and operated within the specifications defined in the product data sheet and where the product is not subject to mechanical damage or chemical attack. The warranty is also conditional on the unit being installed by a licensed electrical contractor. No other warranty is expressed or implied.

Legend Corporation Limited shall not be liable for any direct, indirect, incidental or consequential damages.

**Note: This manual was correct at the time of manufacture. For the latest version of the manual and any technical or safety updates refer to the website:- [www.sclick.com.au](http://www.sclick.com.au) or scan the QR code with a mobile phone.**

CP14731 Rev 4, 7<sup>TH</sup> June 2018

Ordering Information: Part No. HNS420TM

In support of our policy of continuous product improvement we reserve the right to change materials and specifications without notice. Drawings, where used, are not to scale. All dimensions are in millimetres and sizes given are approximate. Where possible, technical MSDS data sheets are made available on the website. All products should be installed and used in accordance with manufacturer's instructions provided. Warning: products may be the subject of registered designs and patents. Refer to website for terms and conditions on warranty.