

DEKS INDUSTRIES
5/841 Mountain Highway
Bayswater
Victoria 3153
www.deks.com.au

DEKS

Technical Documents

1: Drawings DFE101BS&DFE101GS

2: Flashings Technical Specifications

*Follow
Us On*



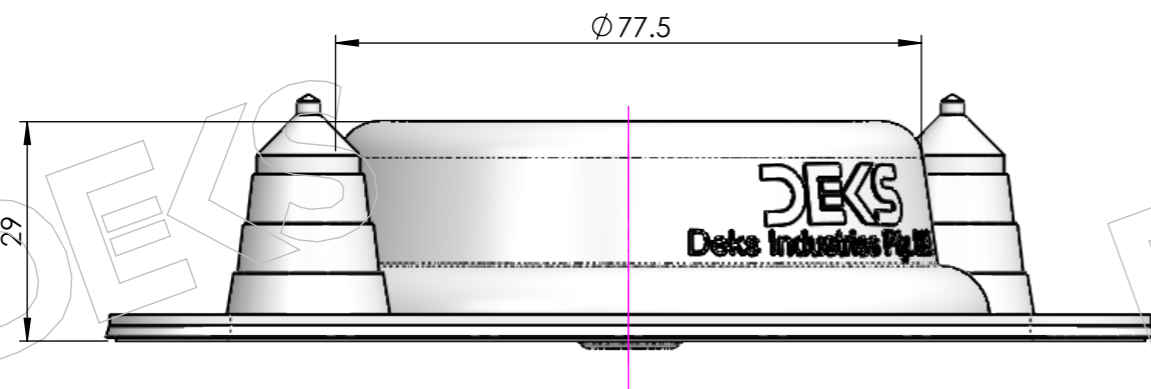
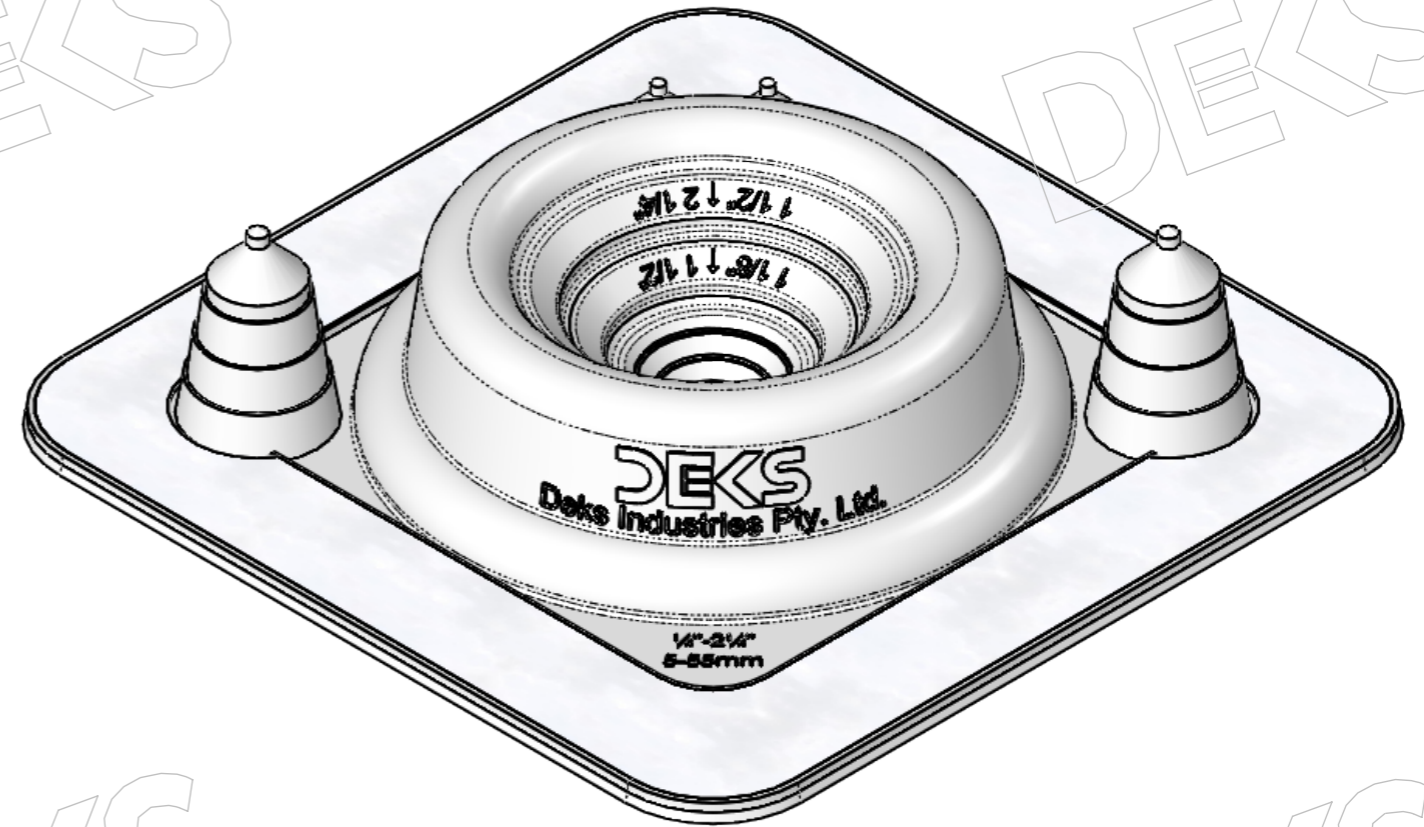
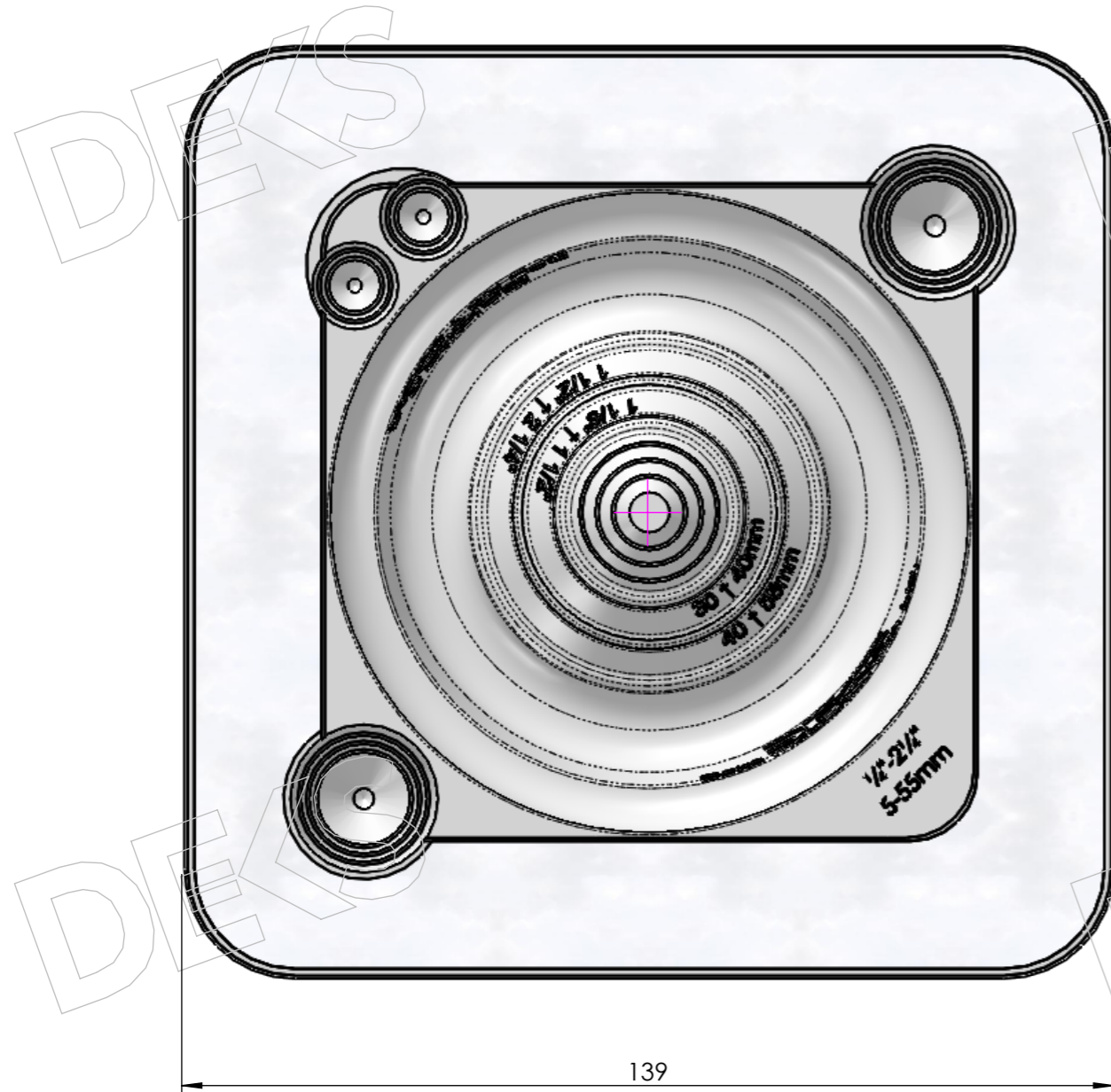

PART NUMBER	DISPLAY NAME	MATERIAL
DFE101GS	Dektite Solar #1 Gry (5-55mm/0.25-2.25")	EPDM/ALU
DFE101BS	Dektite Solar #1 Blk (5-55mm/0.25-2.25")	EPDM/ALU
DFE201RES	Dektite Solar #1 Red Sil (5-55mm/0.25-2.25")	SILICONE/ALU

DEKS Industries Pty. Ltd.
ABN 77 107 135 544

5/841 Mountain Highway
PO Box 569
Bayswater Victoria
3153 Australia

TECHNICAL SPECIFICATION

PRODUCT RANGE: Dektite Roof Original and Premium Flashings

Working Temperature:

Black and Grey EPDM -50°C (-122°F) to 115°C (239°F) and Red Silicone -50°C (-122°F) to 200°C (392°F)

Property	Conditions	Method	Requirements As per IAPMO PS 64 -12	Result
Ultimate Elongation of Rubber	Die C	ASTM D412	Min. 210 % Elongation	Complies
Split Tear Strength of Rubber	Die C	ASTM D624	Min. 0.25 kN/m (EPDM), Min. 0.17 kN/m (Silicone)	Complies
Water Absorption of Rubber	48 hrs @ 158°F	ASTM D471	Max. change 5% by volume	Complies
Ozone Resistance of Rubber	72 hrs @ 104°F & 50 pphm Ozone	ASTM D1149 and D1171	No visible cracks	Complies
Low Temp. Brittleness of Rubber	Non-brittle 3 minutes @ -40°F, Method A	ASTM D2137	No brittleness	Complies
UV resistance of Rubber	UV: One cycle of 4 hrs @ 140°F. Condensation: 2000 hrs @ 122°F	ASTM G154	Max. 50% loss in Tensile Strength & Elongation	Complies
Rain Test for Flashing	Section 25	ANSI/UL 441	Pass	Complies
Temperature Test of Flashing	Section 19	ANSI/UL 441	Max. 90°F above the room temp.	Complies
Horizontal Burning Test / Flame spread of Flashing	Section 7	UL 94	Max. 75 mm/min	Complies

DEKS Industries Pty. Ltd.
ABN 77 107 135 544

5/841 Mountain Highway
PO Box 569
Bayswater Victoria
3153 Australia
P: 03 8727 8800
F: 03 8727 8899

BAL Assessments Roof Flashings

Deks Industries Pty. Ltd. has tested its roof flashing for BAL (Bushfire Attack Level) to clause 20 of AS 1530.8.1 – 2007: “Methods for fire test on building materials, components and structures, Part 8.1 tests on elements of construction for buildings exposed to simulated bushfire attack – radiant heat and small flaming sources” and complies with it as per the table below.

All testing was completed by CSIRO Infrastructure Technologies.

BAL Rating	Models	Polymer	Use on min. 18° Roof Pitch for	CSIRO Report No.	Date of Issue
12.5	DC - Dektite Combo (no split)	EPDM	Metal Roofs	EP1312912	Dec 2013
	DFE – Dektite Premium	EPDM	Metal Roofs	EP1312912	Dec 2013
	DNL – Dektite Nu-Lead	EPDM	Tiled Roofs	EP1312992	Dec 2013
19	FFR – Fast Flash	MS Polymer	Tiled Roofs	EP159257	Dec 2015
29	DC - Dektite Combo (no split)	Silicone	Metal Roofs	EP1312939	Dec 2013
	DFE – Dektite Premium	Silicone	Metal Roofs	EP1312939	Dec 2013
	PFR - Perform	MS Polymer	Tiled Roofs	EP148152	Oct 2014