



CLEVERTRONICS EMERGENCY LIGHTING TEST SWITCH



Internal Configuration

PRODUCT INFORMATION

| | |
|----------------------|--|
| Catalogue Number | ELTK |
| Description | Emergency Lighting Test Switch |
| Construction | Quality Plastic Enclosure |
| Mounting | Surface mount adjacent to switchboard |
| Dimensions L x W x H | 165mm(H) x 140mm(W) x 72mm(D) |
| Switch Type | Key switch operated, spring return – Test, Reset |
| Contactor Type | 4 pole normally closed |
| Timer Configuration | Set to 4 hour discharge test time with automatic reset (can be set to a maximum of 10 hours) |
| Applicable Standards | Manufactured to comply with the requirements of AS2293.1:2005 Section 4.3.1, Manual Test Facilities. |

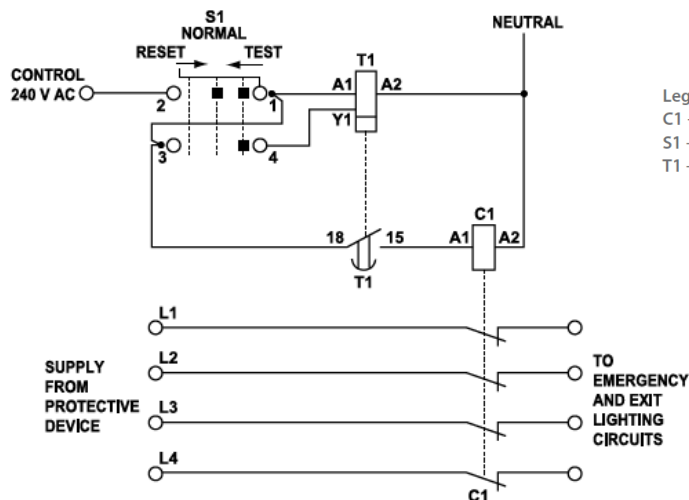

Legend
 C1 - Emergency Lighting Contactor, N/C
 S1 - Emergency Lighting Test Switch
 T1 - Timer, timing set on from one shot impulse