

Linear LED



Linear



FEATURES

- /// 3 year In Home warranty
- /// Excellent airflow 600m³ / h
- /// Long life ball bearing motor
- /// Quiet operation
- /// Turbo fan blade
- /// Duct outlet (150mm diameter)
- /// Efficient 1000w halogen heat lamp included
- /// 4x 6w COB GU10 LED lamps included (MBGU306)
- /// 1x 3-gang switch included
- /// Draft stopper, side ducting, and grill included
- /// Remote control adaptable

DIAGRAM

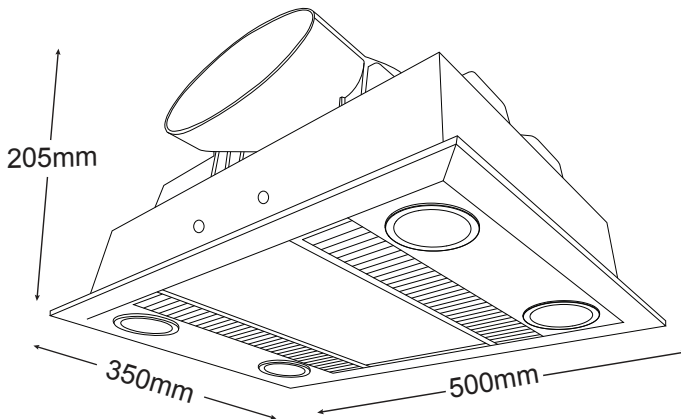

MBHL1000W



MBHL1000S

1 x 1000w Halogen Heat Lamp

4 x 6w COB GU10 LED Lamps

CUT OUT SIZE 450 x 300mm

GRILL SIZE 500 x 350mm

LUMEN 1440

Minimum ceiling depth of 210mm is required