

Ordering Code BCMCP

Used to join sections of straight mesh cable trays. A minimum of three couplers is required per joint. The coupler is supplied complete with an M6 bolt and an M6 flange nut.

Finish:

- Z - Zinc Electro Plated
- H - Hot Dip Galvanised (made to order)
- PG - Pregal
- S - Stainless Steel

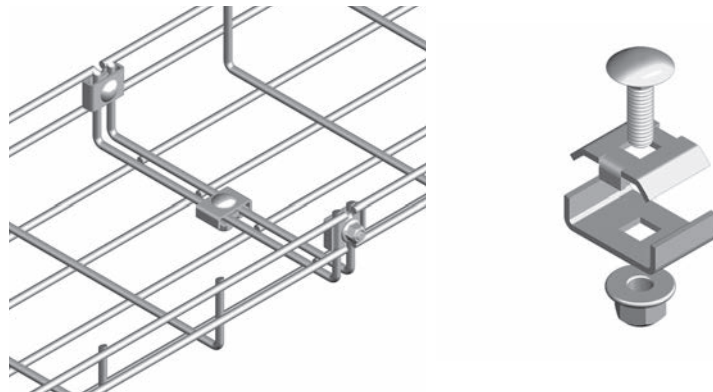

Note - Powder coating and special finishes on request against firm orders only and are non returnable.

BCMCP Coupler

Ordering Code BCMSP

Intended for light loads, the BCMSP provides a quick and simple method of joining sections of straight mesh cable trays.

Finish:

- Z - Zinc Electro Plated
- H - Hot Dip Galvanised (made to order)

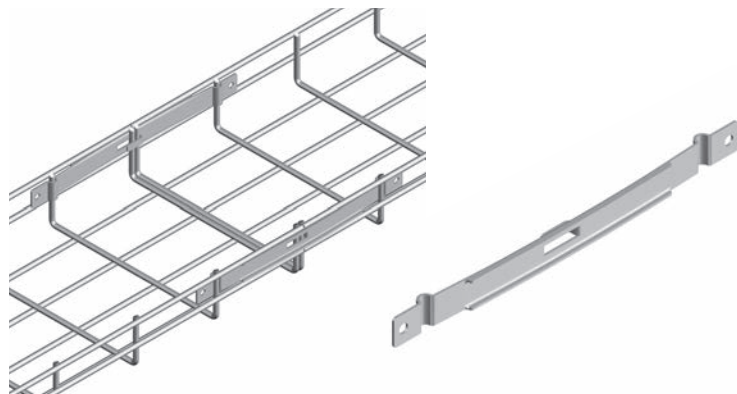

Note - Powder coating and special finishes on request against firm orders only and are non returnable.

BCMSP Fast Fix Splicer

Ordering Code BCMSB

Used to make the joint between two wire mesh cable trays stronger and stiffer. Also used to construct tees, crosses, risers and reducers.

Finish:

- Z - Zinc Electro Plated
- H - Hot Dip Galvanised (made to order)
- PG - Pregal
- S - Stainless Steel

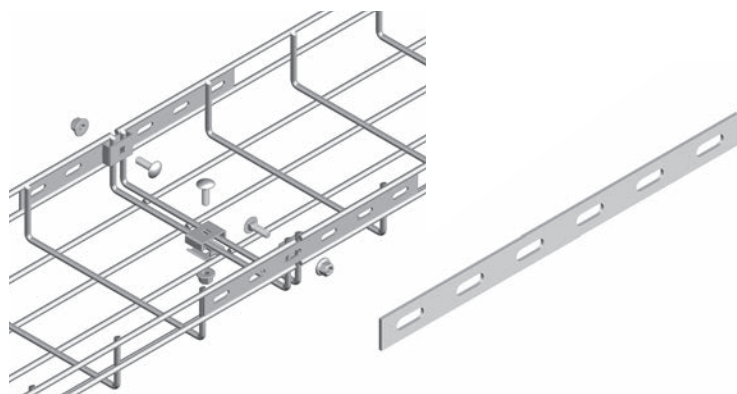

Note - Powder coating and special finishes on request against firm orders only and are non returnable.

BCMSB Strengthening Bar
