



### Main

Range of product	Modicon STB distributed I/O solution
Product or component type	Basic digital input kit
Kit composition	STBDDI3725 module STBXBA3000 base STBXTS1180, 18-terminal screw type connector
Discrete input number	16
Discrete input voltage	24 V
Discrete input voltage type	DC

### Complementary

Input voltage limits	11...30 V at state 1 -3...5 V at state 0
Permissible voltage	30 V
Discrete input current	4.5 mA
Current state 0 guaranteed	<= 1.5 mA
Current state 1 guaranteed	>= 2.5 mA
Discrete input logic	Positive
Response time	2 ms off-to-on 2 ms on-to-off
Protection type	Reverse polarity protection Input protection resistor-limited Power protection integrated fuse on PDM time lag 5 A
Insulation between channels and logic bus	1500 V for 1 minute
Cold swapping	Yes
Hot swapping fallback	Yes for basic NIMs
Product compatibility	I/O base STBXBA3000 Power distribution module STBPDT3100/3105
[Us] rated supply voltage	24 V DC
Supply	Power distribution module
Current consumption	100 mA 5 V DC logic bus
Marking	CE
Overvoltage category	II
Status LED	1 LED green module status (RDY) 1 LED per channel green channel status (IN1 to IN16)
Depth	65.1 mm
Height	18.4 mm
Width	125 mm
Product weight	0.086 kg

### Environment

standards	EN/IEC 61131-2 type 3
product certifications	CSA FM Class 1 Division 2 UL
pollution degree	2 IEC 60664-1
operating altitude	<= 2000 m
IP degree of protection	IP20 EN 61131-2 class 1
ambient air temperature for operation	-25...70 °C without derating

The information provided in this documentation contains general descriptions and/or technical characteristics of the products contained herein. This documentation is not intended as a substitute for and is not to be used for determining suitability or reliability of these products for specific user applications. It is the duty of any such user or integrator to perform the appropriate and complete risk analysis, evaluation and testing of the products with respect to the relevant specific application or use thereof. Neither Schneider Electric Industries SAS nor any of its affiliates or subsidiaries shall be responsible or liable for misuse of the information contained herein.

ambient air temperature for operation	32...140 °F without
ambient air temperature for storage	-40...85 °C without
ambient air temperature for storage	-40...185 °F without
relative humidity	95 % 60 °C without condensation
vibration resistance	+/-0.35 mm 10...58 Hz 3 gn 58...150 Hz 35 x 7.5 mm symmetrical DIN rail 5 gn 58...150 Hz 35 x 15 mm symmetrical DIN rail
shock resistance	30 gn 11 ms IEC 88 reference 2-27

## Offer Sustainability

Sustainable offer status	Green Premium product
RoHS (date code: YYWW)	Compliant - since 0811 - Schneider Electric declaration of conformity
REACH	Reference contains SVHC above the threshold
Product environmental profile	Available
Product end of life instructions	Available

## Dimensions

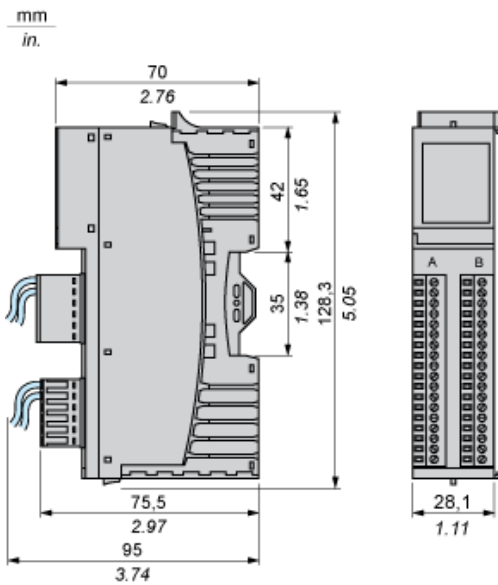

## Wiring Diagrams

### Examples

16 two-wire sensors

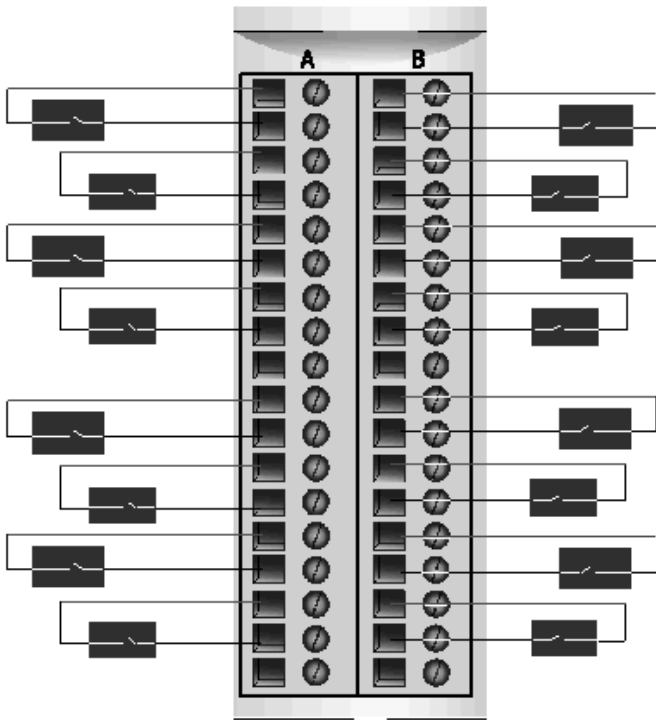

1 three-wire sensor per input group

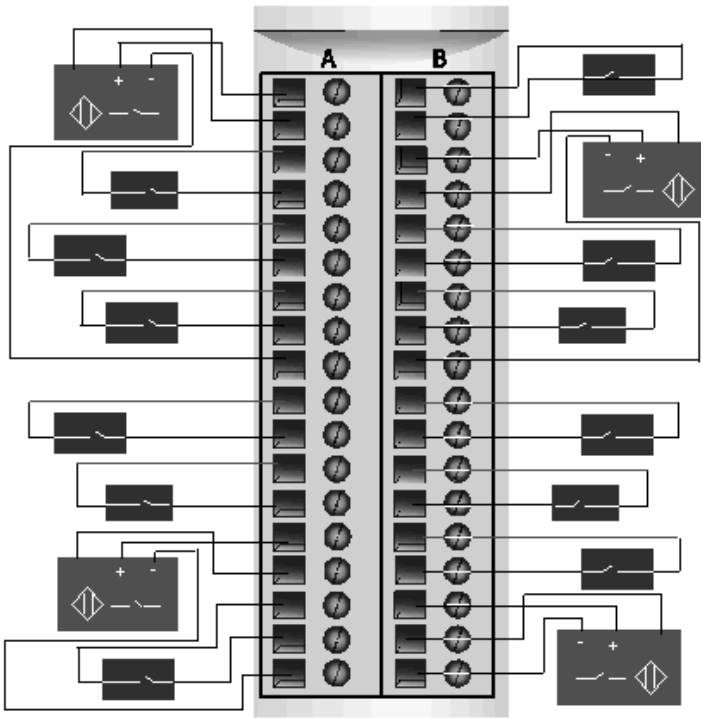

Pin	Left Connector	Right Connector
1	Sensor power group 1 (+)	Sensor power group 3 (+)
2	Input from Sensor 1	Input from Sensor 9
3	Sensor power group 1 (+)	Sensor power group 3 (+)
4	Input from Sensor 2	Input from Sensor 10
5	Sensor power group 1 (+)	Sensor power group 3 (+)
6	Input from Sensor 3	Input from Sensor 11
7	Sensor power group 1 (+)	Sensor power group 3 (+)
8	Input from Sensor 4	Input from Sensor 12
9	Sensor power (-) for a 3-wire sensor (PDM-	Sensor power (-) for a 3-wire sensor (PDM-

	)	
10	Sensor power group 2 (+)	Sensor power group 4 (+)
11	Input from Sensor 5	Input from Sensor 13
12	Sensor power group 2 (+)	Sensor power group 4 (+)
13	Input from Sensor 6	Input from Sensor 14
14	Sensor power group 2 (+)	Sensor power group 4 (+)
15	Input from Sensor 7	Input from Sensor 15
16	Sensor power group 2 (+)	Sensor power group 4 (+)
17	Input from Sensor 8	Input from Sensor 16
18	Sensor power (-) for a 3-wire sensor (PDM- )	Sensor power (-) for a 3-wire sensor (PDM- )