

## Spacial CRN

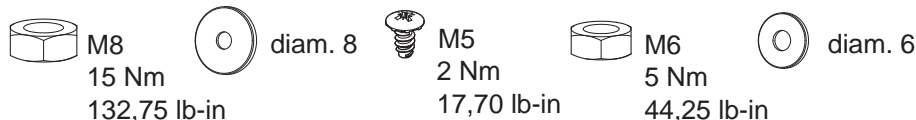

<b>⚠ CAUTION / ATTENTION / ATENCIÓN / VORSICHT / ATTENZIONE / CUIDADO / 小心 / ВНИМАНИЕ</b>	
<p><b>HAZARD OF EQUIPMENT DAMAGE</b> Respect the information provided in the instruction to ensure the functioning of the product. <b>Failure to follow these instructions can result in injury or equipment damage.</b></p>	<p><b>RISQUE DE DETERIORATION DU MATERIEL</b> Respecter les informations fournies sur la notice pour garantir le fonctionnement du produit. <b>Si ces directives ne sont pas respectées, cela peut entraîner des blessures ou des dommages matériels.</b></p>
<p><b>RIESGO DE DETERIORO DEL MATERIAL</b> Respetar la información proporcionada en las instrucciones para garantizar el funcionamiento del producto. <b>El incumplimiento de estas instrucciones puede causar lesiones o daño al equipo.</b></p>	<p><b>GEFAHR VON MATERIALSCHÄDEN</b> Beachten Sie die Angaben in der Betriebsanleitung zur Verfügung gestellt, um die Funktionsweise des Produkts zu gewährleisten. <b>Die Nichtbeachtung dieser Anweisungen kann Verletzungen oder Sachschäden zur Folge haben.</b></p>
<p><b>RISCHIO DI DANNI ALLE APPARECCHIATURE</b> Rispettare le istruzioni fornite per garantire il funzionamento del prodotto <b>Il mancato rispetto di queste istruzioni può provocare infortuni o danni alle apparecchiature.</b></p>	<p><b>RISCO DE DETERIORAÇÃO DO MATERIAL</b> Respetar as informações fornecidas no manual de instruções para assegurar o funcionamento do produto. <b>A não observância destas instruções pode provocar ferimentos pessoais, ou danos no equipamento.</b></p>
<p><b>设备受损风险</b> 为保证正常使用该产品请仔细阅读本产品说明书。 不遵循上述说明可能导致人身伤害或设备损坏。</p>	<p><b>ОПАСНОСТЬ ПОВРЕЖДЕНИЯ ОБОРУДОВАНИЯ</b> Следуйте информации, указанной в инструкции, для гарантии правильного функционирования продукта. <b>Несоблюдение этих инструкций может привести к травме или повреждению оборудования.</b></p>

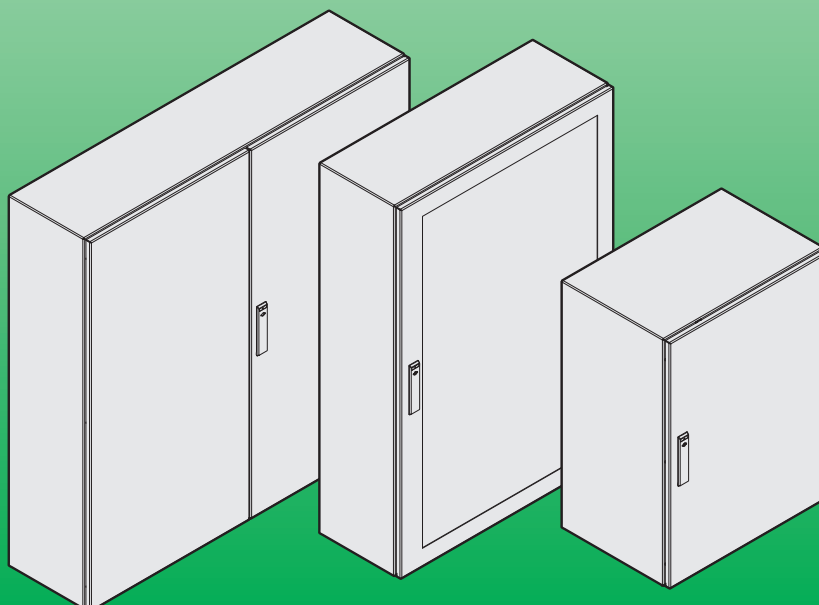
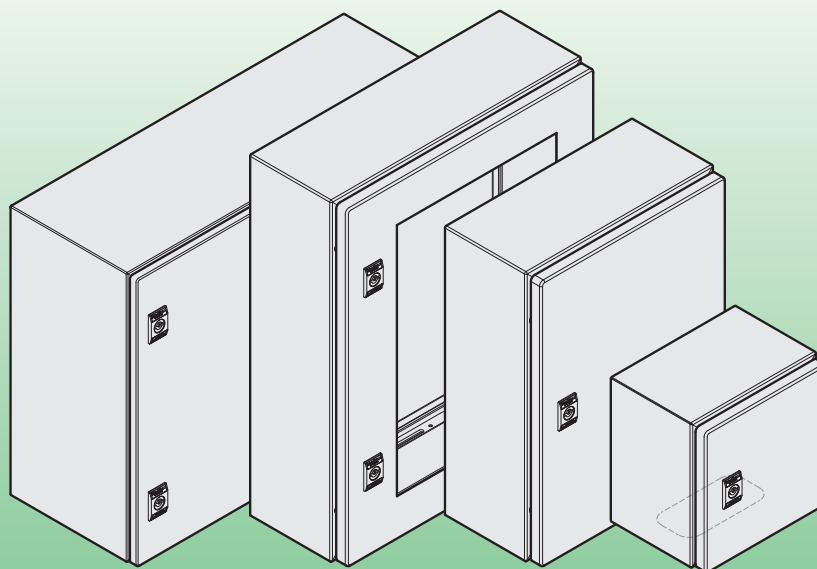
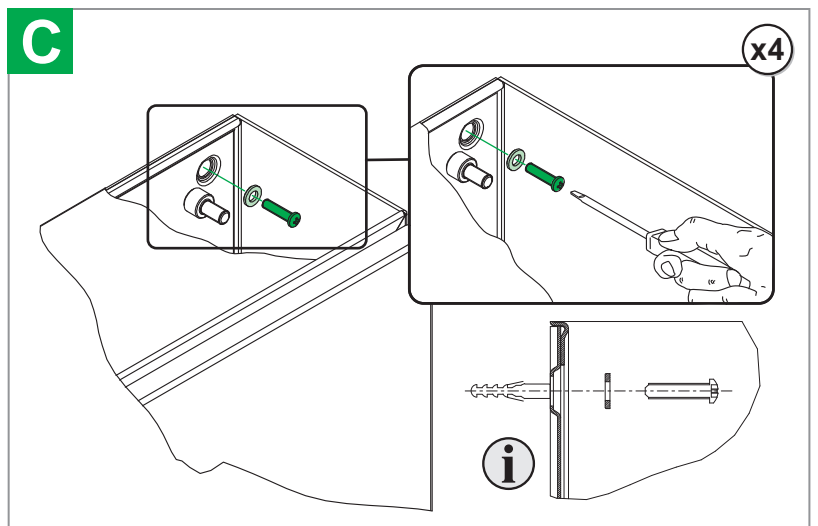
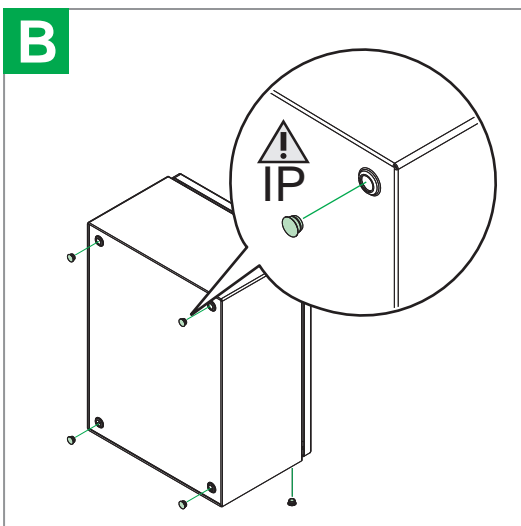
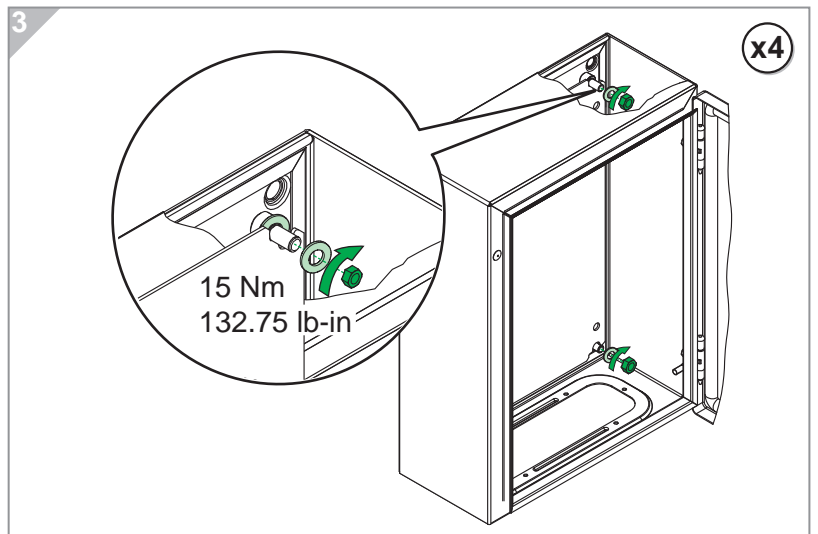
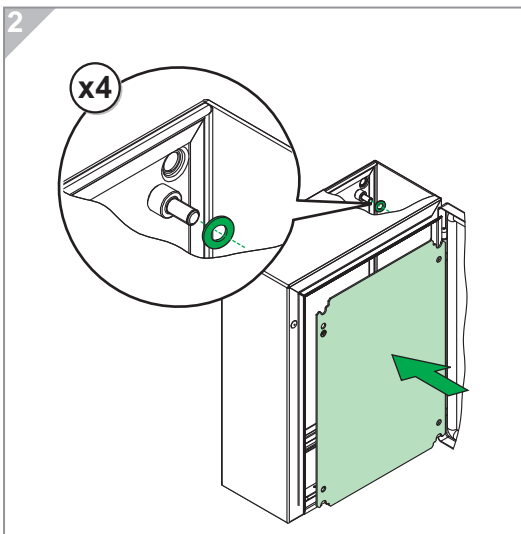
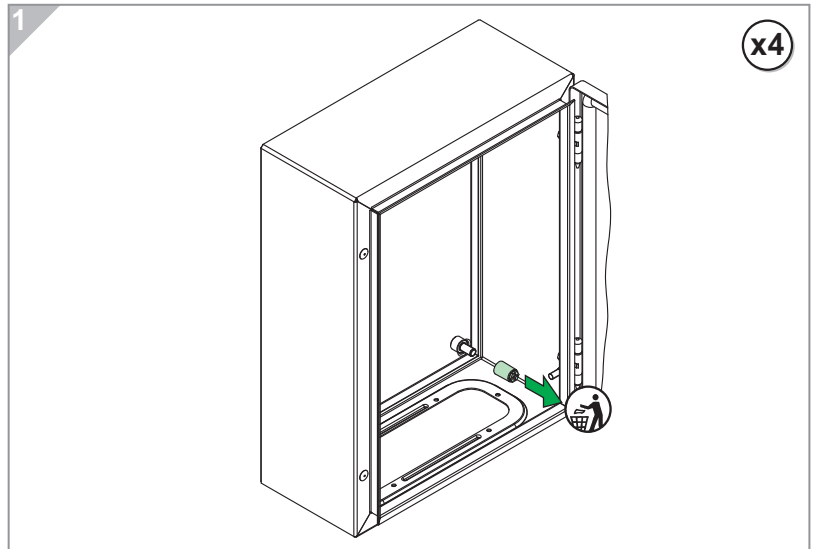
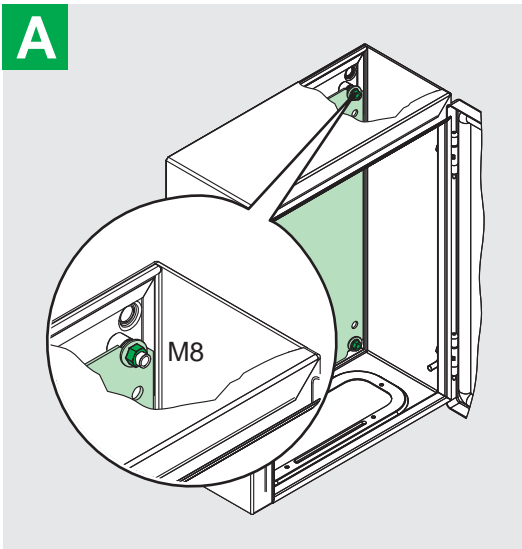

To maintain the same UL type rating, all conduit fittings and other components installed in openings made in the enclosure must have its same ratings and only wall fixing bracket NSYPFCR may be used. When installed as a Type 2 or 3R enclosure, drill a drain hole (3.2 - 6.4 mm (1/8 - 1/4 in) diameter) in the lowest part of the bottom wall.

It is the customer responsibility to fulfill requirements of section 19 (Openings) of UL508A Standard and Section 9.6 (Equipment openings) of UL50E Standard.

Il est de la responsabilité du client de respecter les exigences de la section 19 (Openings) de la Norme UL508A et la section 9.6 (Equipment openings) de la norme UL50E

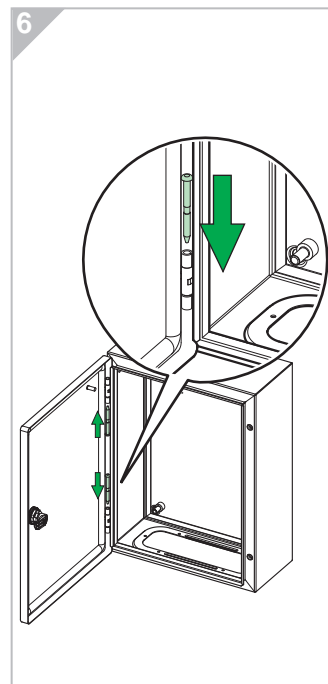
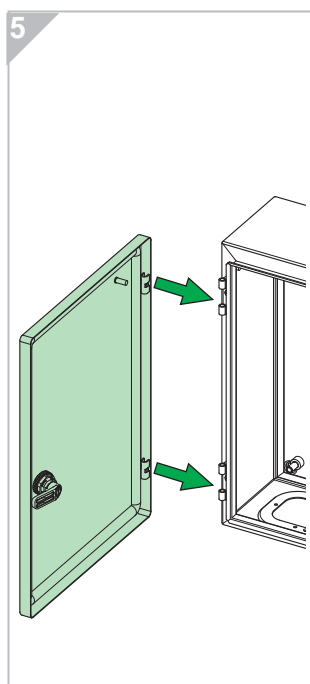
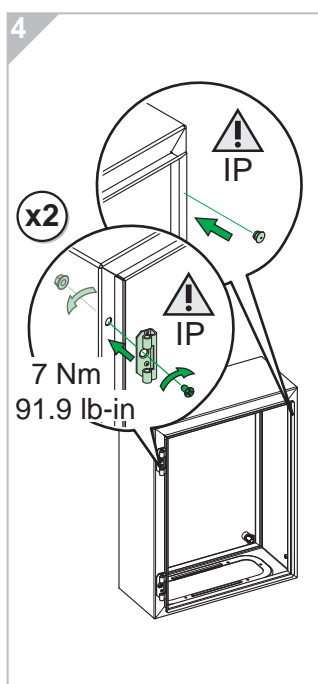
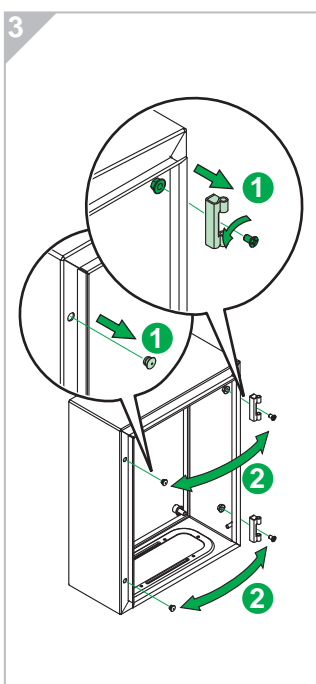
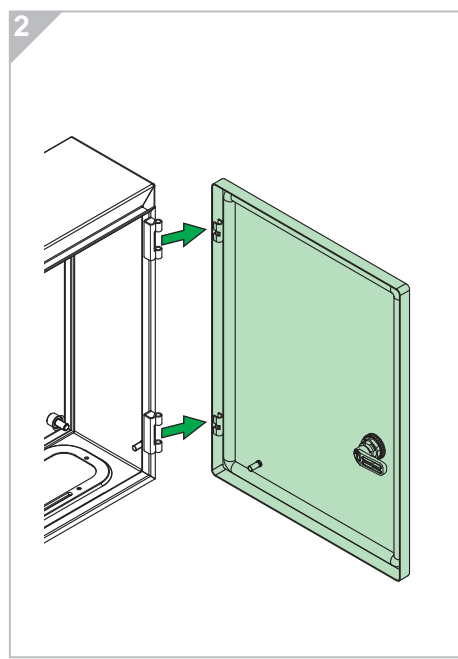
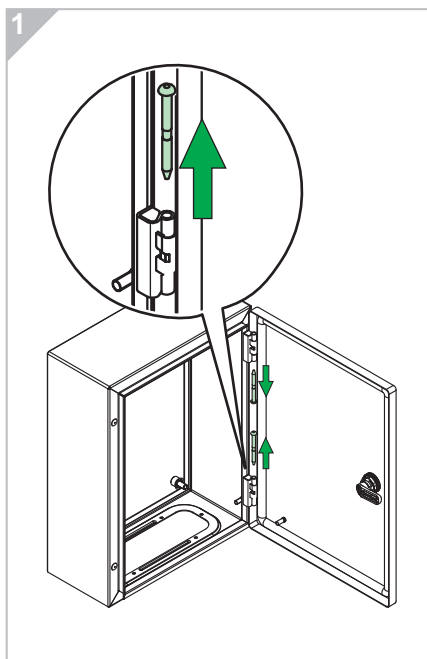
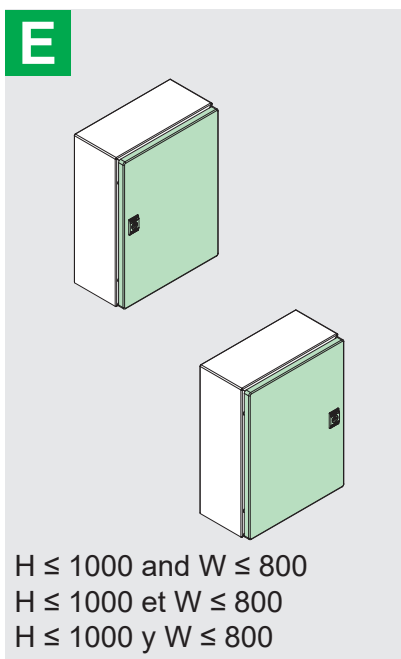
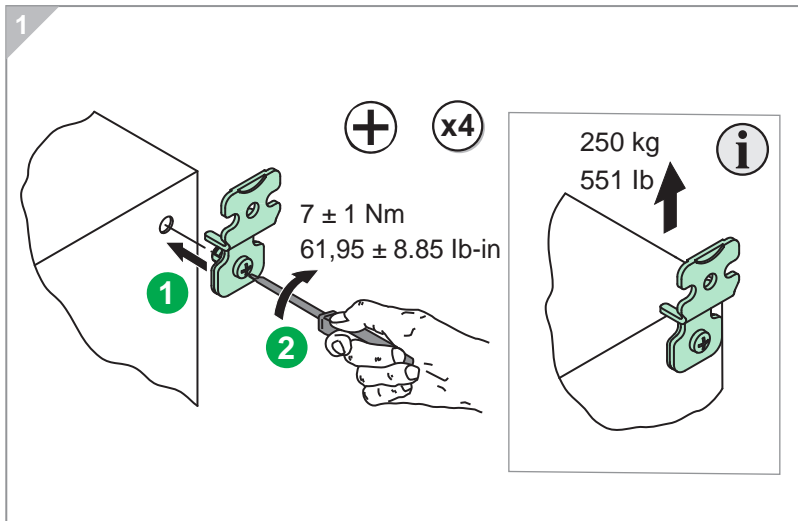
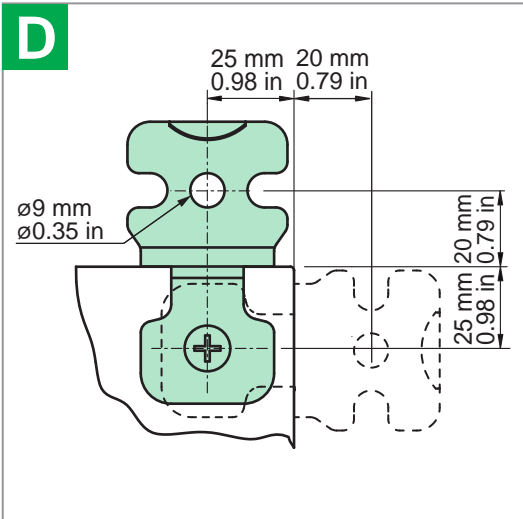

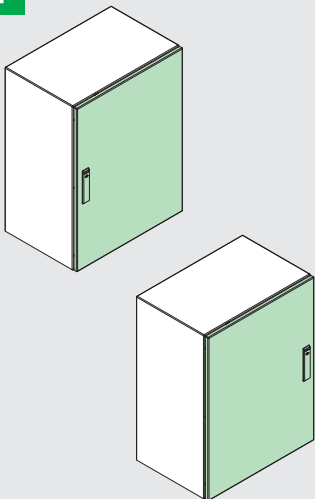
**E'**

$H \geq 1200$  and  $W \leq 800$   
 $H \geq 1200$  et  $W \leq 800$   
 $H \geq 1200$  y  $W \leq 800$

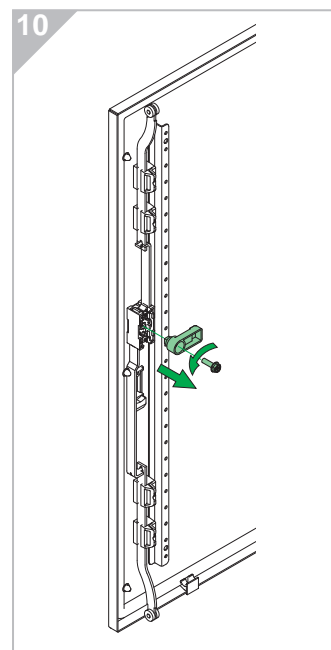
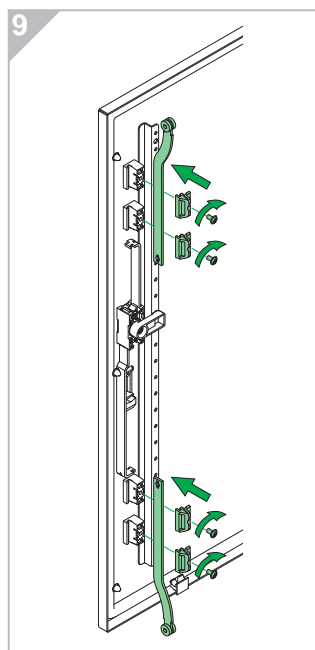
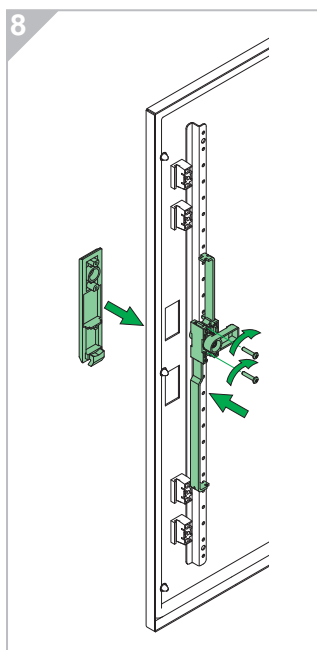
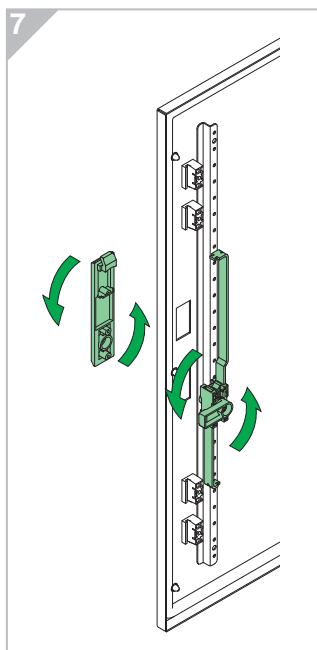
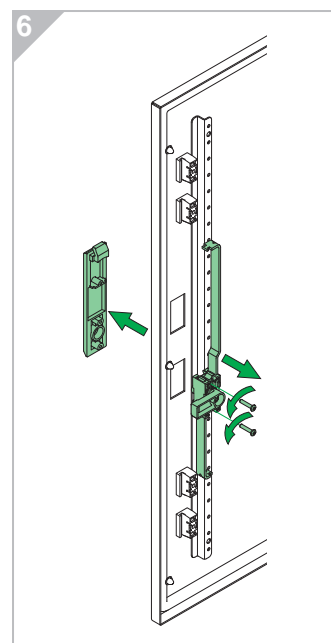
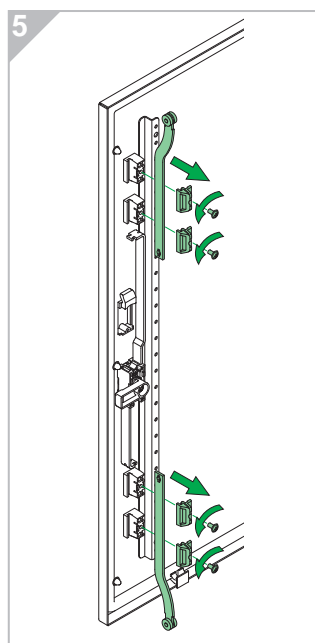
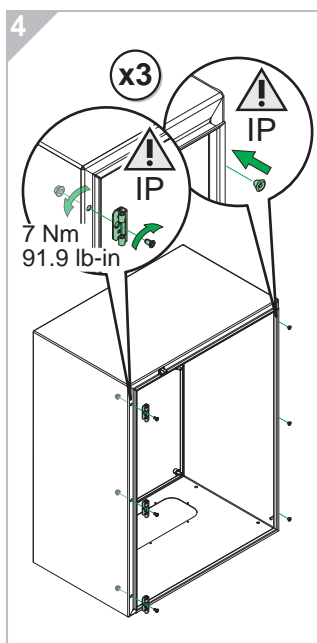
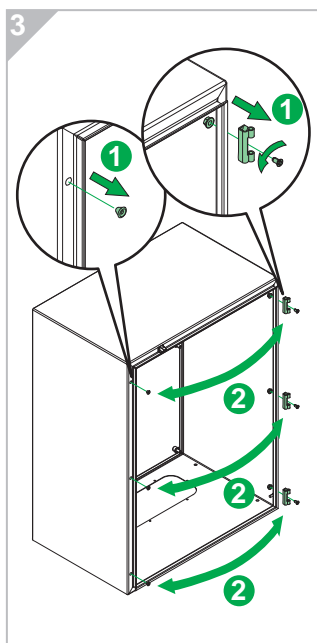
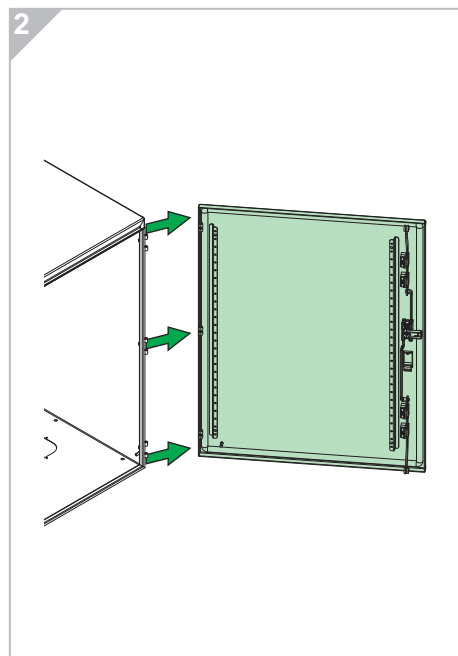
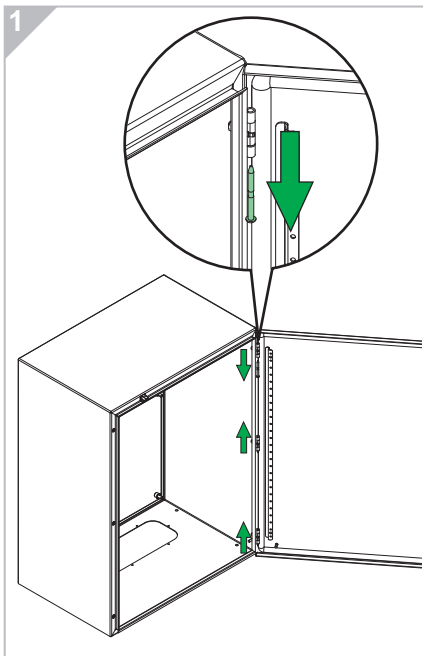

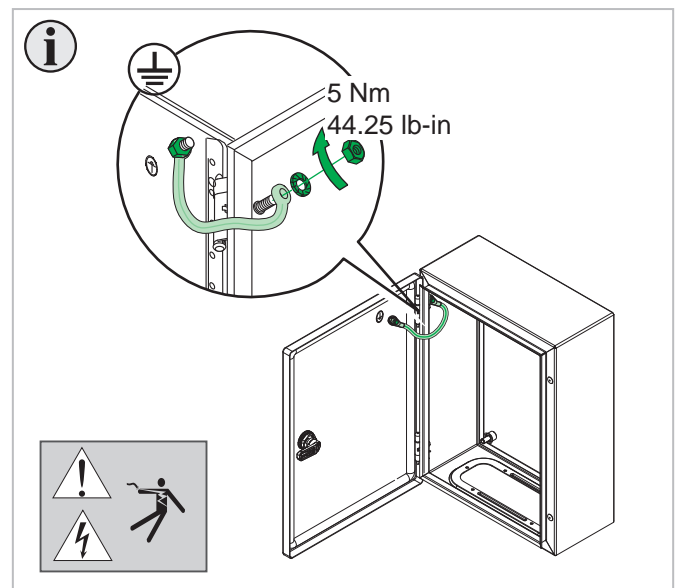
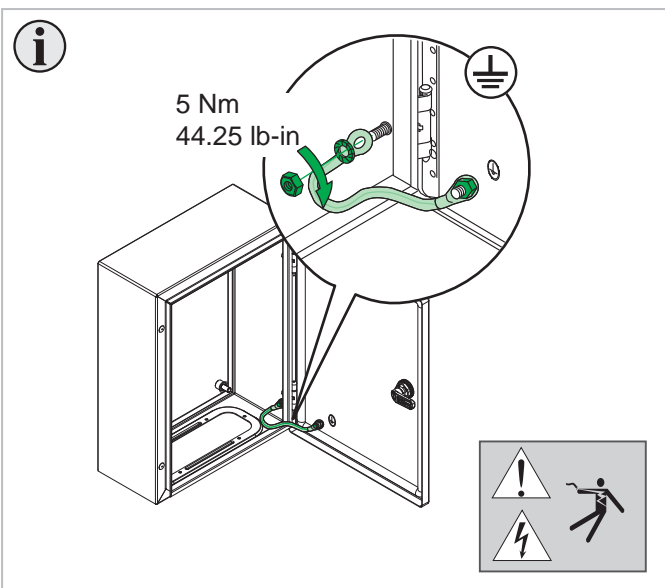
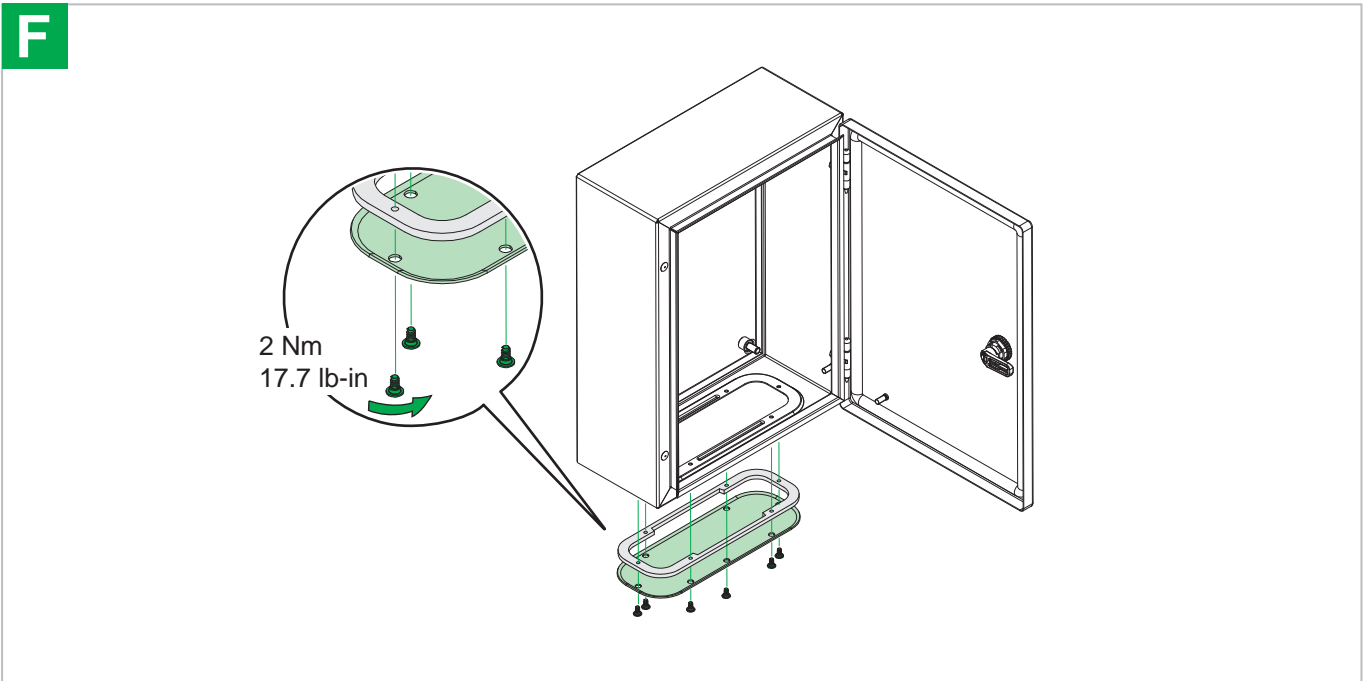
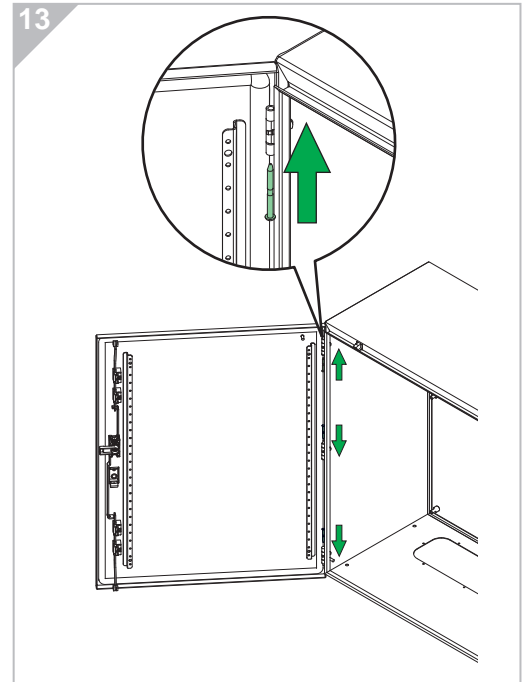
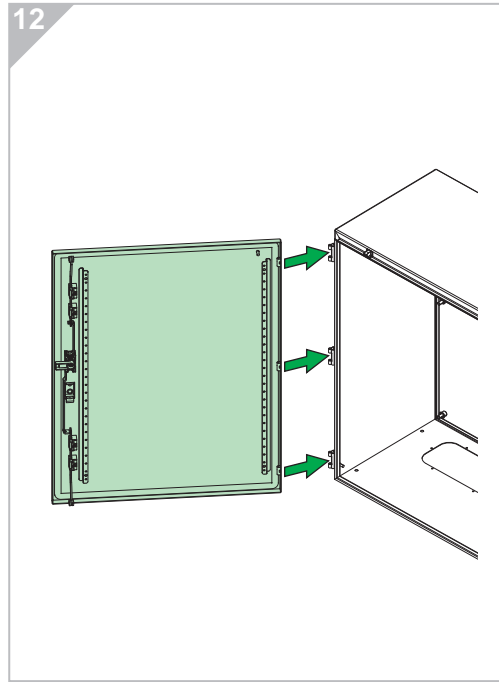
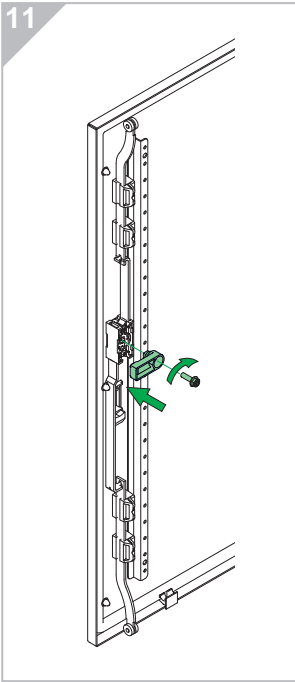

**G**

$H \leq 1000$  and  $W \leq 800$   
 $H \leq 1000$  et  $W \leq 800$   
 $H \leq 1000$  y  $W \leq 800$

**1** Insert the handle into the door and attach the lock cylinder.

**2** Attach the lock cylinder to the handle.

**3** Insert the handle into the door.

**4** Tighten the handle to the door. Torque:  $1,2 \text{ N.m}$  /  $10.6 \text{ lb-in}$ .

**i**

**1** Use pliers to remove the old handle.

**2** Remove the old lock cylinder.

**3** Remove the old handle. Torque:  $4,5 \text{ Nm}$  /  $39.8 \text{ lb-in}$ .

**i**

**i**

$\phi 6 \text{ mm}$   
 $\phi 0,26 \text{ in}$

$\phi 7,5-10 \text{ mm}$   
 $\phi 0,3-0,39 \text{ in}$

G'

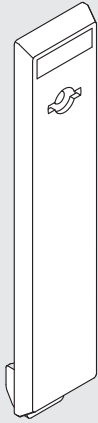

H ≥ 1200 or W ≥ 1000  
 H ≥ 1200 ou W ≥ 1000  
 H ≥ 1200 o W ≥ 1000

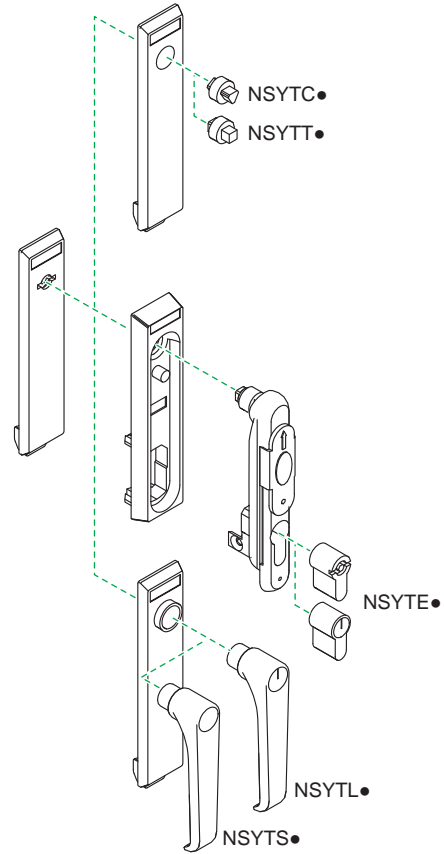

i

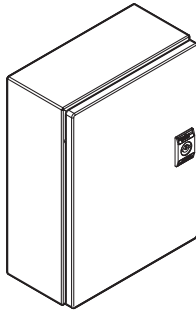

Structural accessories Accessoires structuraux Accesorios estructurales		Possible combinations Possibles combinaisons Posibles combinaciones			
		S-1	S-2	S-3	S-4
S-1	NSYTJ...		✓	✓	✓
S-2	NSYPFCR	✓		✓	
S-3	NSYSPF...	✓	✓		
S-4	NSYCOCN80	✓			

Application accessories Accessoires d'application Accesorios de aplicación		Possible combinations Possibles combinaisons Posibles combinaciones						
		A-1	A-2	A-3	A-4	A-5	A-6	A-7
A-1	NSYMB... NSYMM... NSYMS... NSYMF... NSYMR...		✓	✓	✓	✓	✓	✓
A-2	NSYPIN...	✓		✓				
A-3	NSYSDCR...	✓	✓		✓			✓
A-4	NSYDLM... NSYDLCR...	✓		✓				
A-5	NSYDLA... NSYDLPLM...	✓						
Dimensions 600 mm wide Dimensionne largeur 600 mm Dimensiones ancho 600 mm		Possible combinations Possibles combinaisons Posibles combinaciones						
A-6	NSYVDM...P	✓						
A-7	NSYVDM...F	✓		✓				

---

**Schneider Electric Industries SAS**  
35, rue Joseph Monier  
CS 30323  
F - 92506 Rueil Malmaison Cedex

[www.schneider-electric.com](http://www.schneider-electric.com)

GEX7454201

**Ce produit doit être installé, raccordé et utilisé en respectant les normes et/ou les règlements d'installation en vigueur.**

En raison de l'évolution des normes et du matériel, les caractéristiques et cotes d'encombrement données ne nous engagent qu'après confirmation par nos services.

**This product must be installed, connected and used in compliance with prevailing standards and/or installation regulations.**

As standards, specifications and designs change from time to time, always ask for confirmation of the information given in this publication.