

Catalogue No: 800T-QH2R

PL 30.5mm LED 12-130V RED

Operator Control Devices > Pushbuttons and Control Switches > Pushbuttons and Pilot Lights > Allen-Bradley
800T/800H Pushbuttons > Pilot Light Units (Standard Units) > Metal



Pilot Light 30.5mm Metal Led Red 12-130V ACDC

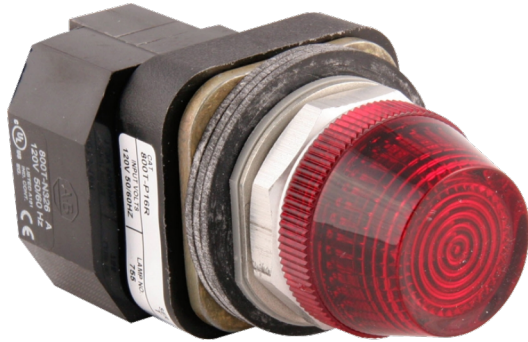

- 800T (metal) and 800H (plastic) 30.5mm product lines are designed and constructed to perform in the most demanding industrial environments.
- Button caps made from thermoplastic polyester resin and deliver excellent resistance to corrosive agents and ensure color identification is never lost.
- Operator bushings are made from die cast zinc alloy giving strength and stability in installation.
- Riveted construction of the operator bushing, diaphragm seal and base plate, by four secure steel rivets, provides increased durability and tamper resistance.

Representative Photo Only
(actual product may vary based on configuration selections)

SPECIFICATIONS

Product Series	800T
Component Type Pushbutton and Pilot Lights	Pilot Light
Diameter, lens	37.7 mm
Colour, Lens	Red colour
Material, Lens	Glass-Filled Nylon / PA6 / PA66 (Polyamide 6)
Material, Bezel	Zinc
Material, Body / Housing	Zinc Alloy, Die-Cast, Chrome-Plated material
Terminal Type	Screw Terminal(s)
Material, Terminal	Chromated Zinc & Stainless Steel
Tightening Torque, Max	0.9 Nm
Tightening Torque, Min	0.65 Nm
Wire / Conductor Size (Max)	14 AWG (2.08 mm ²)
Wire / Conductor Size (Min)	18 AWG (0.823 mm ²) min
Lamp Module Included	Yes
U _{min} , Service Voltage, AC, Min	12 V AC
U _{max} , Service Voltage, AC, Max	130 V AC
U _{min} , Service Voltage, DC, Min	12 V DC
U _{max} , Service Voltage, DC, Max	130 V DC
Rated Frequency	50 / 60 Hz
Lamp Holder	Integrated Lamp Module
Contact Block Included	No
Mounting	30.5mm Mounting
U _i , Rated Insulation Voltage	690 V (rms)
Dielectric Strength	2.2kV for 1 minute
Electrical Service Life at U _n , In	1000000 cycles
Mechanical Service Life	200000 cycles
Operating Temperature, Max	55 °C max
Operating Temperature, Min	-40 °C min

Catalogue No: **800T-QH2R**

PL 30.5mm LED 12-130V RED

Operator Control Devices > Pushbuttons and Control Switches > Pushbuttons and Pilot Lights > Allen-Bradley
800T/800H Pushbuttons > Pilot Light Units (Standard Units) > Metal



Storage Temperature, Max	85 °C max
Storage Temperature, Min	-40 °C min
Relative humidity, min	50 %RH
Relative Humidity, Max	95 %RH
IP Rating	IP65 IP66
Shock Acceleration (Max.)	100 g
Shock Duration (Max.)	11 ms
Vibration Acceleration (Max.)	10 m/s ²
Vibration Displacement (Peak to Peak Max.)	1.52 mm
Vibration Frequency, Operational (Max.)	2000 Hz
Standards Compliance	UL 508 CSA C22.2 No. 14 EN 60947-5-1 EN 60947-5-5 ISO 13850
Certifications	CE CSA UL CCC

REFERENCES

IECEX Certificate	-
Supplier Declaration of Conformity:	-
Installation Guide:	-
User Manual:	-
Manufacturer Datasheet:	800T/800H_Manufacturer Datasheet
Manufacturer Catalogue & Product Selection:	800TQH2R_Manufacturer Datasheet

Catalogue No: **800T-QH2R**

PL 30.5mm LED 12-130V RED

Operator Control Devices > Pushbuttons and Control Switches > Pushbuttons and Pilot Lights > Allen-Bradley
800T/800H Pushbuttons > Pilot Light Units (Standard Units) > Metal

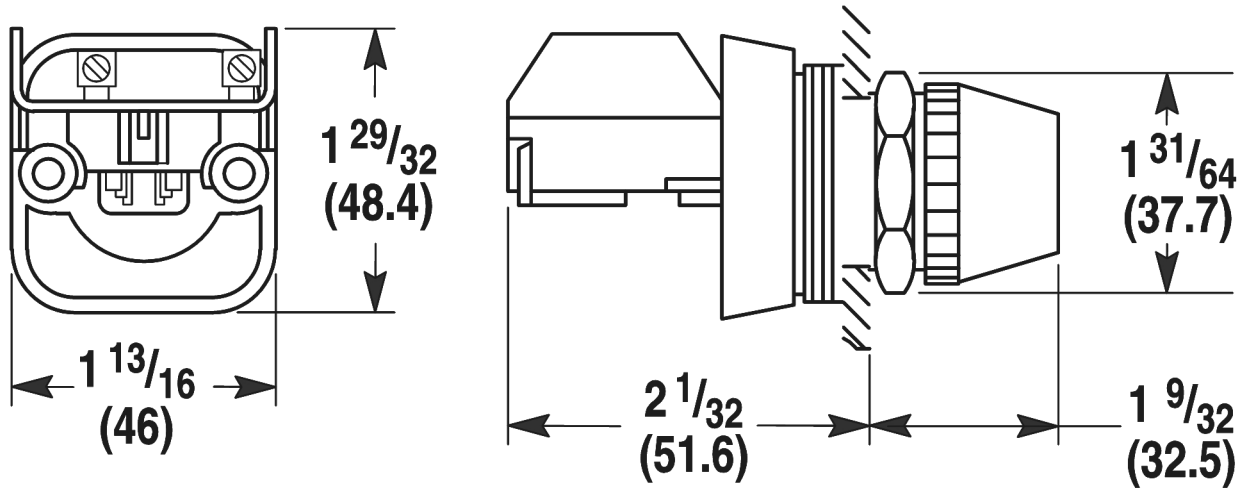

Full Voltage, Neon and
Dual Input Pilot Light
Shipping Wt. 5 oz (0.14 kg)

Dimension Diagram