

ZBRRC

Programmable receiver - 4 PNP - 200 mA - 24 V DC
- 2 pushbuttons - 6 LEDs



Main

Range of product	Harmony
Product or component type	Programmable receiver
Device short name	ZBRRC
Product specific application	Interface to PLC
Function of module	Monostable
Reset time	2 ms (time delay)
Transmission frequency	2405 MHz
Level or class	5M00G7W
Antenna type	Omnidirectional

Complementary

Nominal output current	
Output type	Transistor PNP
Output contacts	4 PNP
Time delay range	0.5 s (tolerance: - 15...15 %)
Maximum switching current	0.2 mA
Minimum switching current	
[Us] rated supply voltage	24 V DC - 15...20 %
Voltage drop	<= 2 V DC at 2 A
Communication port protocol	Zigbee (green power) at 2.4 GHz conforming to IEEE 802.15.4
Maximum sensing distance	100 m (in free field) 25 m (transmitter in a plastic box type XAL D and receiver in a metal enclosure) 40 m (transmitter in box type XAL D, receiver in metal enclosure and use relay-antenna)
Response time	< 30 ms (after transmitter clicks)
Channels utilisation	<= 32 per receiver
Utilisation category	DC-13 conforming to EN/IEC 60947-5-1
Power consumption in VA	20 VA DC
Power consumption in W	20 W
Breaking capacity	4.8 W per output
Short-circuit protection	0.4 A fuse fast blow
Operating position	Any position without derating
Electrical connection	1 conductor cable 0.14...2.5 mm ² - AWG 26...AWG 14 - solid - without cable end conforming to IEC 60947-1 2 conductors cable 0.14...1.5 mm ² - AWG 26...AWG 16 - solid - without cable end conforming to IEC 60947-1 1 conductor cable 0.14...4 mm ² - AWG 26...AWG 12 - flexible - with cable end conforming to IEC 60947-1 2 conductors cable 0.14...1.5 mm ² - AWG 26...AWG 16 - flexible - with cable end conforming to IEC 60947-1
Tightening torque	0.5...1 N.m conforming to EN/IEC 60947-1
Housing material	Self-extinguishing plastic
Status LED	1 LED, color: green for power ON 1 LED, color: green and yellow for reception signal 4 LEDs, color: green for relay ON
Mounting support	
Rated short-duration power frequency withstand voltage	1 kV 50 Hz conforming to EN/IEC 60947-5-1
[Uimp] rated impulse withstand voltage	0.8 kV
Surge withstand	0.5 kV (differential mode) conforming to IEC 61000-4-5

The information provided in this documentation contains general descriptions and/or technical characteristics of the performance of the products contained herein. This documentation is not intended as a substitute for and is not to be used for determining suitability or reliability of these products for specific user applications. It is the duty of any such user or integrator to perform the appropriate and complete risk analysis, evaluation and testing of the products with respect to the relevant specific application or use thereof. Neither Schneider Electric Industries SAS nor any of its affiliates or subsidiaries shall be responsible or liable for misuse of the information contained herein.

	1 kV (common mode) conforming to IEC 61000-4-5
Max power consumption in W	1 mW
Number of channels	1
Modulation technique	O-QPSK
Bandwidth	5 MHz
Antenna gain	0 dBi
Width	36 mm
Height	108 mm
Depth	75 mm
Product weight	0.13 kg

Environment

standards	EN/IEC 60947-5-1
radio agreement	RSS SRRRC ICASA ANATEL ARIB T66 FCC
product certifications	CCC CSA C-Tick GOST UL
marking	CE
ambient air temperature for storage	-40...70 °C
relative humidity	90 % at -20...55 °C without condensation conforming to ETSI EN 300 440-1
vibration resistance	+/- 7.5 mm (f = 5...14 Hz) conforming to IEC 60068-2-6 2 gn (f = 8...150 Hz) conforming to IEC 60068-2-6
shock resistance	10 gn (duration = 16 ms) 6000 shocks conforming to IEC 60068-2-27
IP degree of protection	IP20 on casing conforming to IEC 60529 IP20 on terminals
pollution degree	2 conforming to IEC 60664-1
overvoltage category	III conforming to IEC 60664-1
insulation resistance	> 500 MOhm at 500 V DC conforming to NF C 20-030
[Ui] rated insulation voltage	< 60 V conforming to IEC 60664-1
electromagnetic compatibility	Immunity for industrial environments conforming to EN/IEC 61000-6-2 Conducted RF disturbances (test level: 10 V) conforming to IEC 61000-4-6 Conducted emission conforming to EN 300-489-1 Immunity to microbreaks and voltage drops (test level: 7 ms) conforming to IEC 61000-4-11 Conducted and radiated emissions , class B conforming to CISPR 22 Electrostatic discharge immunity test (test level: 8 kV) in free air (in insulating parts) conforming to IEC 61000-4-2 Electrostatic discharge immunity test (test level: 6 kV) on contact (on metal parts) conforming to IEC 61000-4-2 Susceptibility to electromagnetic fields (test level: 10 V/m) 80...2000 MHz conforming to IEC 61000-4-3 Susceptibility to electromagnetic fields (test level: 3 V/m) 80...2700 MHz, distance = 20 m conforming to IEC 61000-4-3 Electrical fast transient/burst immunity test (test level: 2 kV) power supply wires conforming to IEC 61000-4-4 Radiated emission conforming to ETSI EN 300 440-1 Conducted emission conforming to ETSI EN 300 489-3 Radiated emission conforming to ETSI EN 300 440-2 Electrical fast transient/burst immunity test (test level: 1 kV) PNP output wires conforming to IEC 61000-4-4 1.2/50 µs shock waves immunity test (test level: 0.5 kV) differential mode conforming to IEC 61000-4-5 1.2/50 µs shock waves immunity test (test level: 1 kV) common mode conforming to IEC 61000-4-5

Offer Sustainability

Sustainable offer status	Green Premium product
RoHS (date code: YYWW)	Compliant - since 1113 - Schneider Electric declaration of conformity

REACH	Reference not containing SVHC above the threshold
Product environmental profile	Available
Product end of life instructions	Available

Programmable Receiver

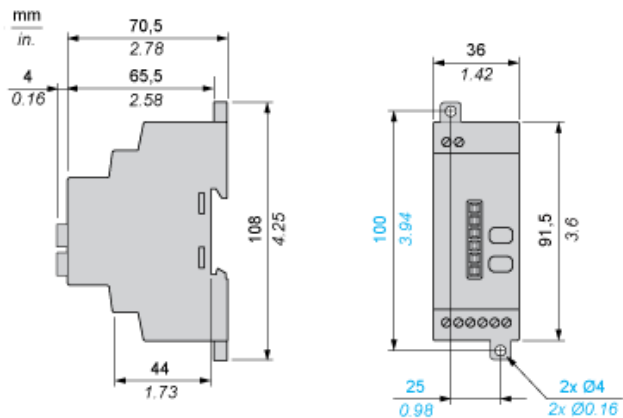

Receiver Clearance

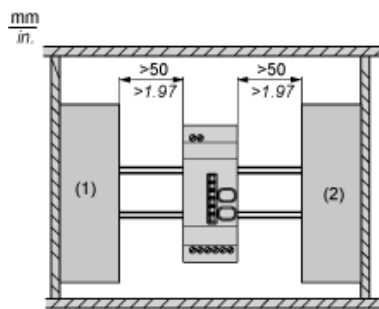

- (1) Drive
- (2) Power Supply or PLC

Receiver Mounting

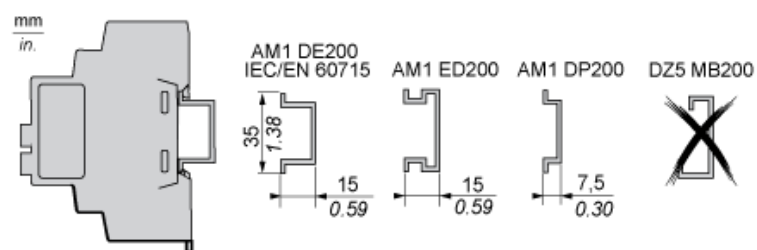

Programmable Receiver

Wiring Diagram

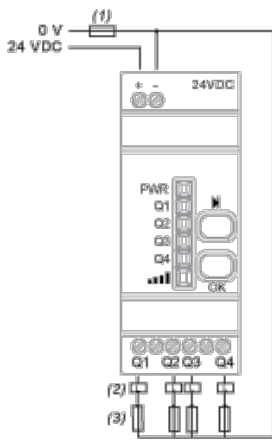

- (1) 400 mA fast-blow fuse
- (2) $I_{max} = 200 \text{ mA}$
- (3) $I_{max} = 300 \text{ mA}$