

## Signal Isolator v5 SI132

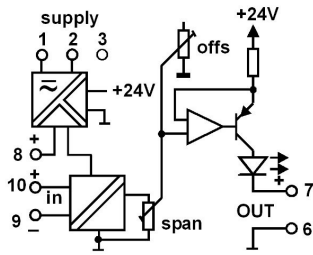

The SI132 is a field configurable isolating converter providing true 3-way galvanic isolation up to 2000Vrms for standard process signals. Inputs, outputs and response time are programmable via coding plugs. Final calibration is trimmed using the front accessible 15-turn 'offs' and 'span' adjustments. The output signal level is indicated by a green LED giving a clear indication of module function, signal presence and loop condition for current outputs. Various power supply choices are available ranging from 240Vac down to 8dc all provide power isolation and surge protection.



### Specifications

Size:	52 W x 70 H x 110 D (mm).
Housing material:	ABS.
Mounting:	DIN-Rail, gear plate.
Termination:	Screw terminals with covers.
Protection class:	IP40.
Weight:	0.370 kg.
Accuracy:	0.15% of span.
Front 'OFFS' adjust:	±20% typical
Front 'SPAN' adjust:	±20% typical
Linearity:	0.15% of span above 0.2mA.
Repeatability:	0.1% of span.
Response time:	see table on right.
Input Impedance:	51Ω(20mA/10mA range). 1kΩ (1mA range). 2M7Ω (10V/5V range). 560kΩ (2V/1V range).
Temperature effect:	0.025% per°C.
Operating temperature range:	-10...-60°C.
Storage temp. range:	-20...+70°C.
Output loop drive:	10mA into 0 - 1.8kΩ, 20mA.
Output load change effect:	less than 0.2% up to maximum load stated.
Auxiliary output:	20Vdc, maximum 22mA.
Input/output isolation:	>2kV rms.
Power requirements:	3W.
Electromagnetic compatibility:	AS/NZS 4251.1(EN 50081.1)

**Type no. SI132 - X 1 1 1 0**

- Power Supply:**
- 1 = 90-280Vac 50/60Hz (65-280Vdc).
  - \*) 3 = 16-48Vac 50/60Hz (10-60Vdc)
  - \*) 6 = 8 - 60Vdc.

Please specify required input, output and response time if required. The factory default is 4-20mA input, 4-20mA output, 500mS response.

\*) = Price Extra.

### To Change Ranges

1. Disconnect power to unit.
2. Unclip housing lid and withdraw unit from housing.
3. Set the coding plugs as required.
4. Reassemble unit and connect power.
5. Adjust "span" and "offs" pots to recalibrate.
6. Change the label information to the new input/output values.

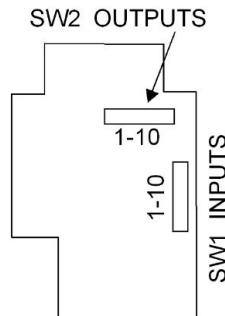

### Input Selection - SW1

Input	1	2	3	4	5	6	7	8
4-20mA		X	X	X				X
0-1mA	X		X	X			X	
0-10mA		X	X	X	X		X	
0-20mA		X	X	X			X	
0-1V			X	X			X	
0-2V			X				X	
0-5V				X			X	
1-5V				X				X
0-10V							X	

### Response Time - SW1

Response time	9	10
5msec		
50msec	X	
500msec		X

### Output Selection - SW2

Output	1	2	3	4	5	6	7	8	9	10
4-20mA	X	X								
0-20mA					X					
0-10mA			X							
0-1mA				X						
0-1V					X				X	
0-2V					X					X
0-5V					X			X		
1-5V	X	X						X		
0-10V					X		X			

### Connection

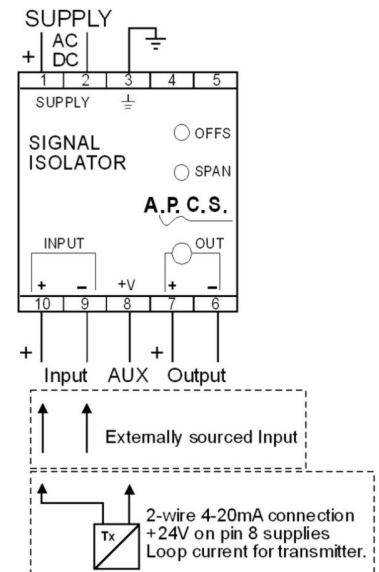

In the interest of development and improvement, APCS reserve the right to amend, without notice, details contained in this publication. APCS will accept no legal liability for any errors, omissions or amendments.